

ASSEMBLY INSTRUCTION

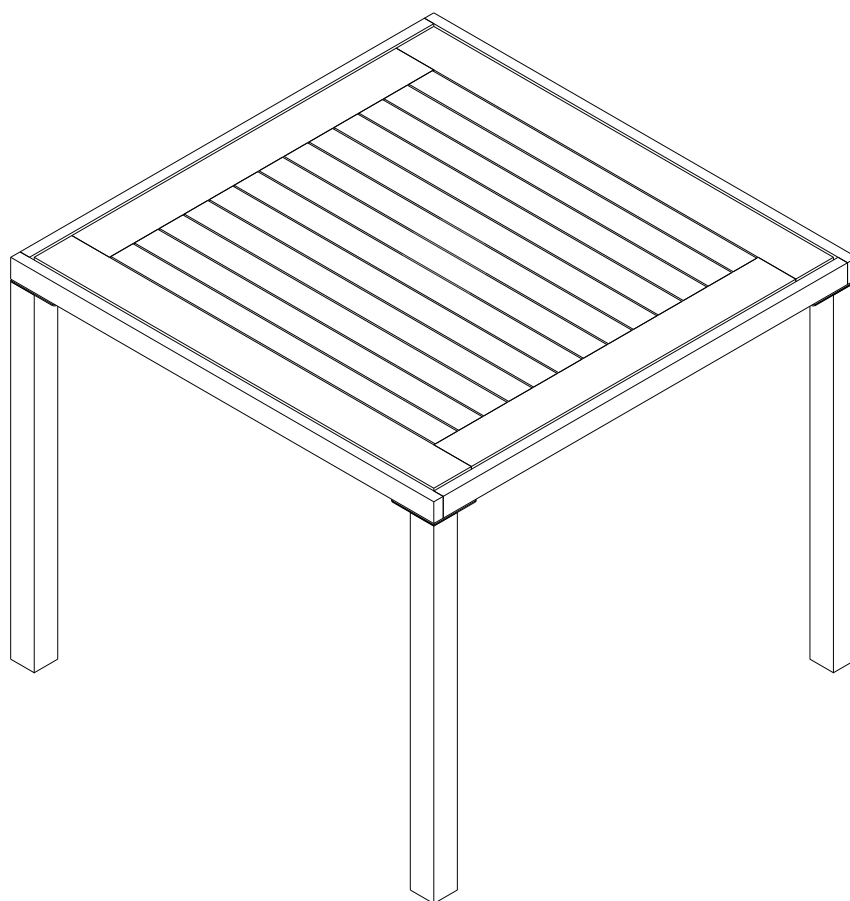

NOTE: 50% TIGHTEN BEFORE FIXING ALL BOLTS

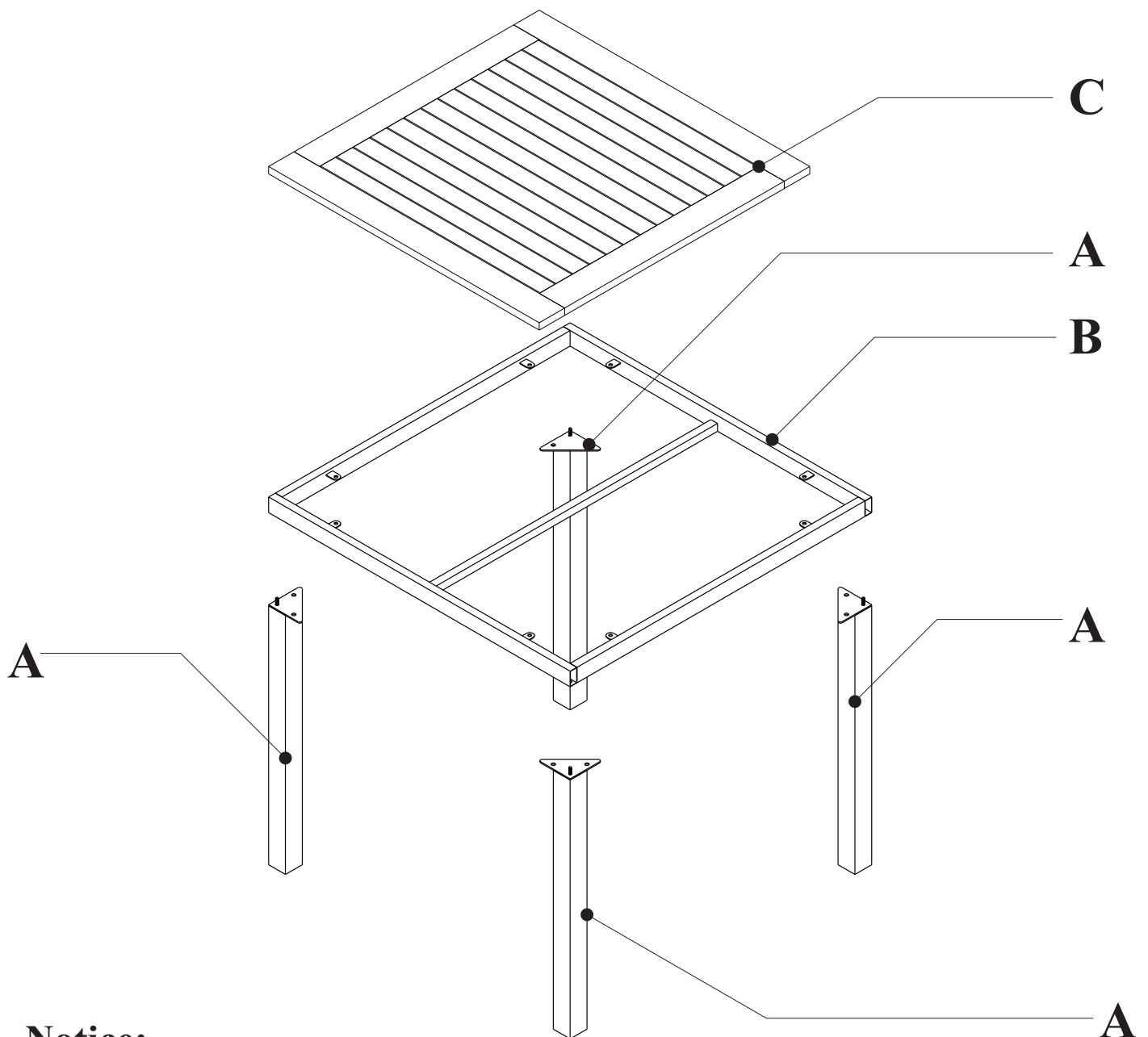

Notice:

- 1. 50% Tighten before fixing all screws, Allen wrench is recommended instead of an electric drill.**
- 2. Place the item on a flat ground to adjust and make sure it remains stable.**
- 3. Tighten up all screws with tools gradually.**
- 4. If the screws are not aligned with holes during assembly, please loosen all the other screws to 50% and continue the assembly process.**
- 5. If the item is not stable, please loosen all the screws, adjust it on a flat ground and tighten up all screws again.**
- 6. Note : If one or some screws are fully tightened during assembly, chances are the others will not be aligned with holes. In addition, all the holes are designed to be relatively larger to provide more space for the adjustment of the screws.**

Part List & Hardware

A

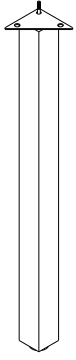

Table Leg (4 pcs)

B

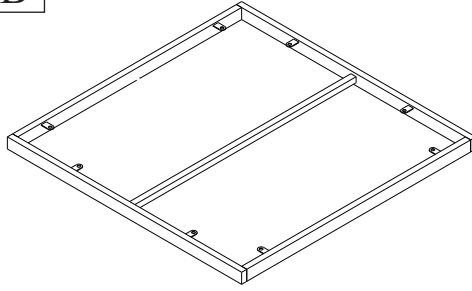
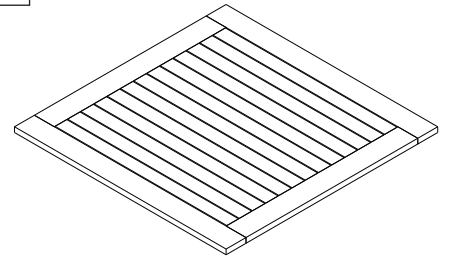

Table Top (1 pc)

C



Wood Table Top (1 pc)

1

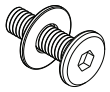

Bolt M6x15 mm (8 pcs)

2

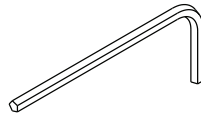

Allen key (1pc)

3



Screw (8 pcs)

4

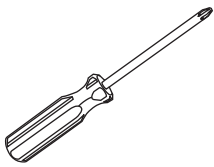

Screwdriver (1 pc)

STEP 1

Connect Table Top (B) & Table Leg (A), tighten Table Leg (A) with Table Top (B)

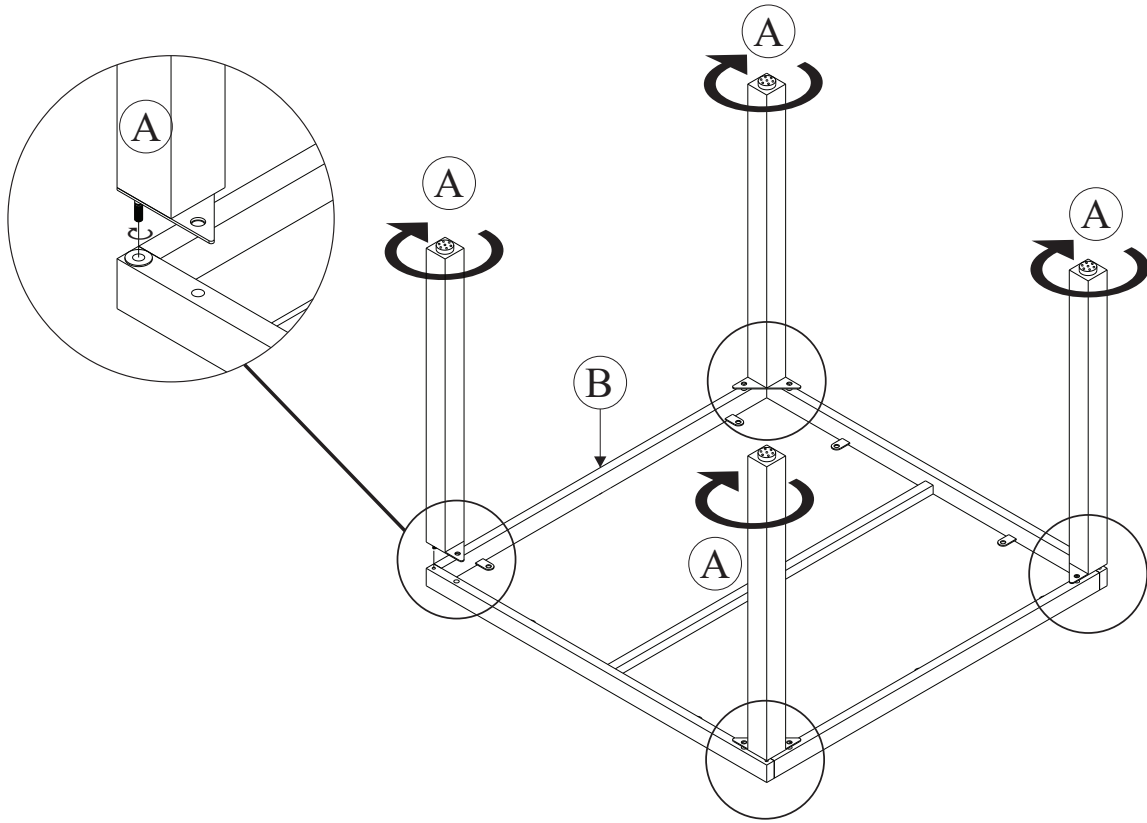

Please do not over-rotate, it is recommended to rotate 10-11 times

STEP 2

Connect part from STEP 1 with Bolt (1) to complete table

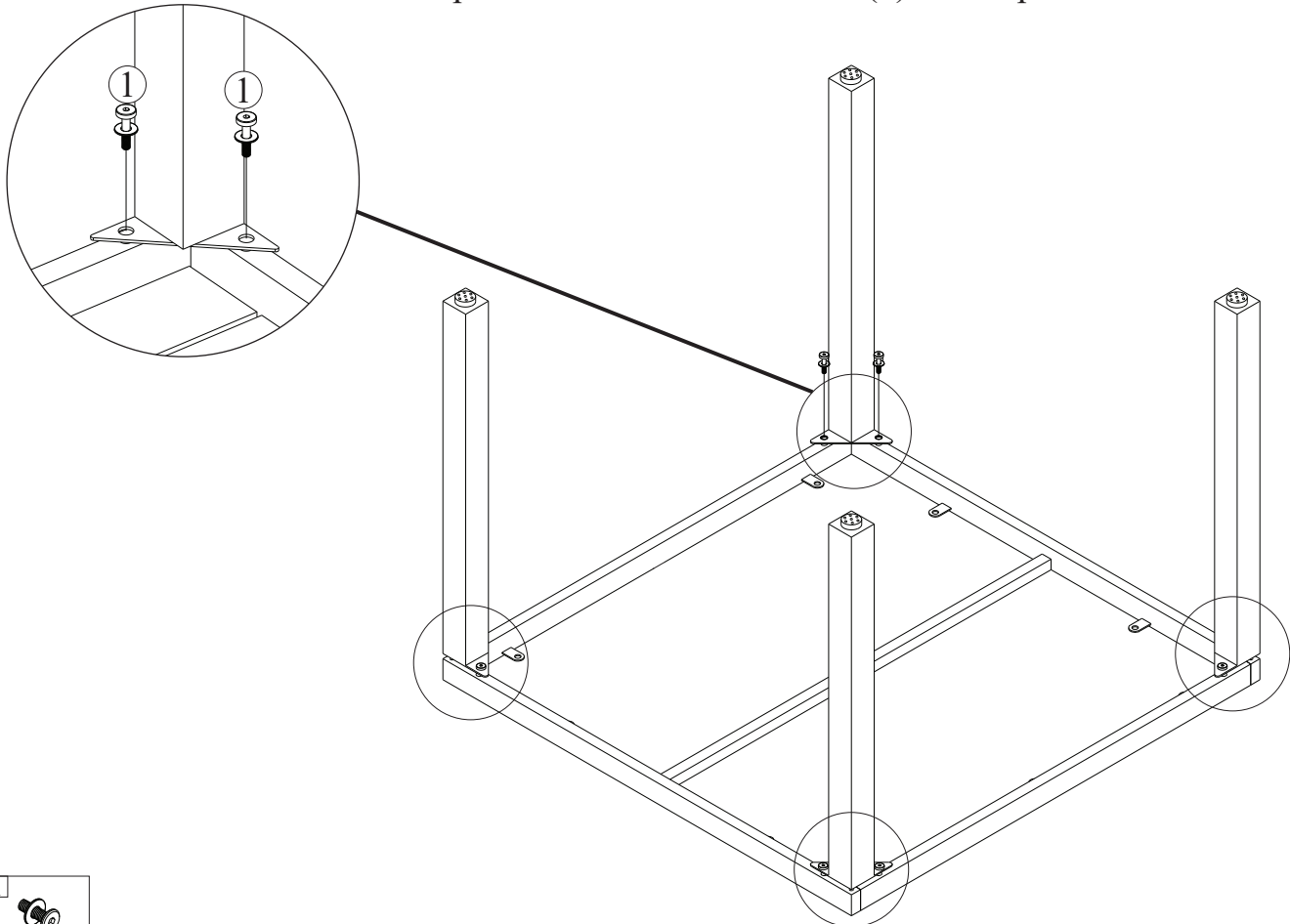

1
8 pcs

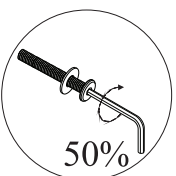

STEP 3

Put on wood table top (C) & Screw (3) to complete table

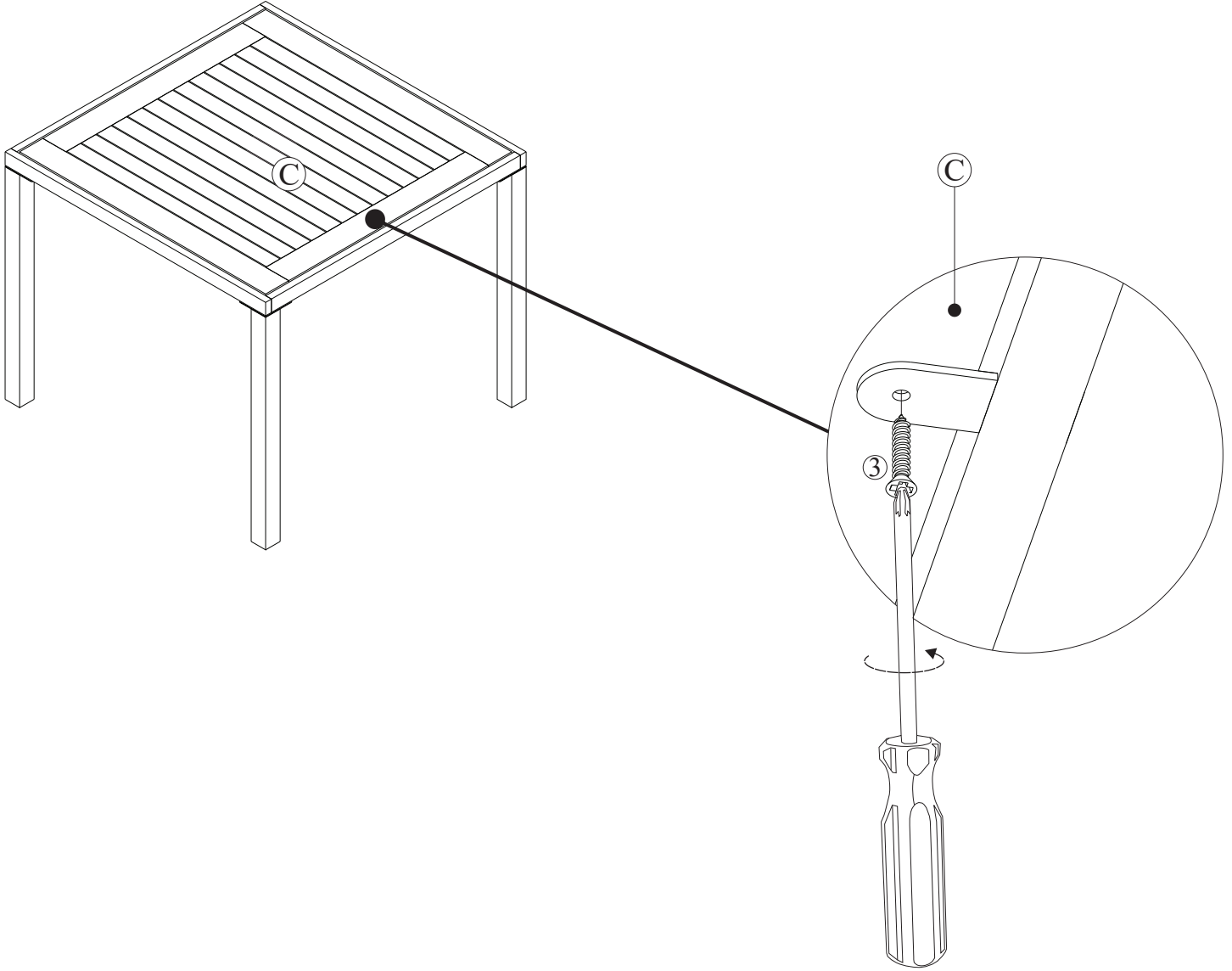

3
8 pcs

