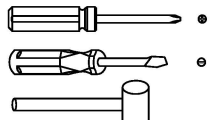

ASSEMBLY INSTRUCTIONS

ASSEMBLY REQUIREMENTS:	2-Person Assembly	2 Hours Assembly Time (Approximate)	Tools Required: (Not Provided)	Phillips Screwdriver Flat Screwdriver Mallet	
-------------------------------	-------------------	-------------------------------------	--------------------------------	--	---

Thank you for purchasing our product!

Please refer and use this assembly instruction to assemble the product. Contact our customer service department in case there are any missing or damage parts or hardware. Replacement parts are normally shipped within 2 or 3 days.

We appreciate your business!



ASSEMBLY PREPARATION

1. Remove all packaging materials, staples and packing straps from the carton.
2. Refer to Parts List and Hardware List and ensure they are complete before assembly.
3. Place all wooden parts on a clean, flat and soft surface (e.g. carpet or rug) to prevent parts from getting scratched.

SAFETY PRECAUTION:

1. KEEP ALL HARDWARE PARTS OUT OF REACH OF CHILDREN.
2. DISPOSE PLASTIC PACKAGING MATERIAL IMMEDIATELY TO AVOID ANY RISK OF SUFFOCATION TO CHILDREN AND ANIMALS.

TIPS FOR ASSEMBLY:

1. Allow ample room for assembly and in close proximity to where product will be placed.
2. Assemble the product on a surface that does not scratch or damage the exterior gloss and finish of the furniture.
3. Identify all of the parts, hardware and quantities required for each step.
4. During assembly, do not over-tighten any fittings as this may cause damage.
5. DO NOT USE POWER TOOLS TO ASSEMBLE THIS PRODUCT.
6. Always place the product on a flat surface.
7. Do not sit or stand on the partially assembled product; only use the product for which it is intended.

CARE AND MAINTENANCE

- Use a slightly damp cloth to clean the product. Do not use bleach or abrasive cleaning material.
- Check all the fittings periodically and re-tighten as necessary. Do not use the product if any of the parts damaged or broken.
- Never allow any kind of liquid to remain on your furniture. Absorption can cause wood to warp or delaminate.
- Do not place hot items (e.g. hot drinks) directly onto the wood surface.
- Do not drag and/or pull the furniture.

This product is for indoor and household use only - not for commercial use.

ASSEMBLY INSTRUCTIONS

PARTS LIST

Part#	Description	Qty
1	Drawer Front Panel	1pc
2A	Drawer Left Panel	1pc
2B	Drawer Right Panel	1pc
3	Drawer Back Panel	1pc
4	Drawer Bottom Panel	1pc
5	Top Panel	1pc
6A	Left Side Panel	1pc
6B	Right Side Panel	1pc

Part#	Description	Qty
7	Left Frame Panel	1pc
8A	Shelf - A	1pc
8B	Side Divide Panel	1pc
8C	Front Divide Panel	1pc
9	Shelf - C	2pcs
10	Right Frame	1pc
11A	Top Rear Apron	1pc
11B	Top Front Apron	1pc





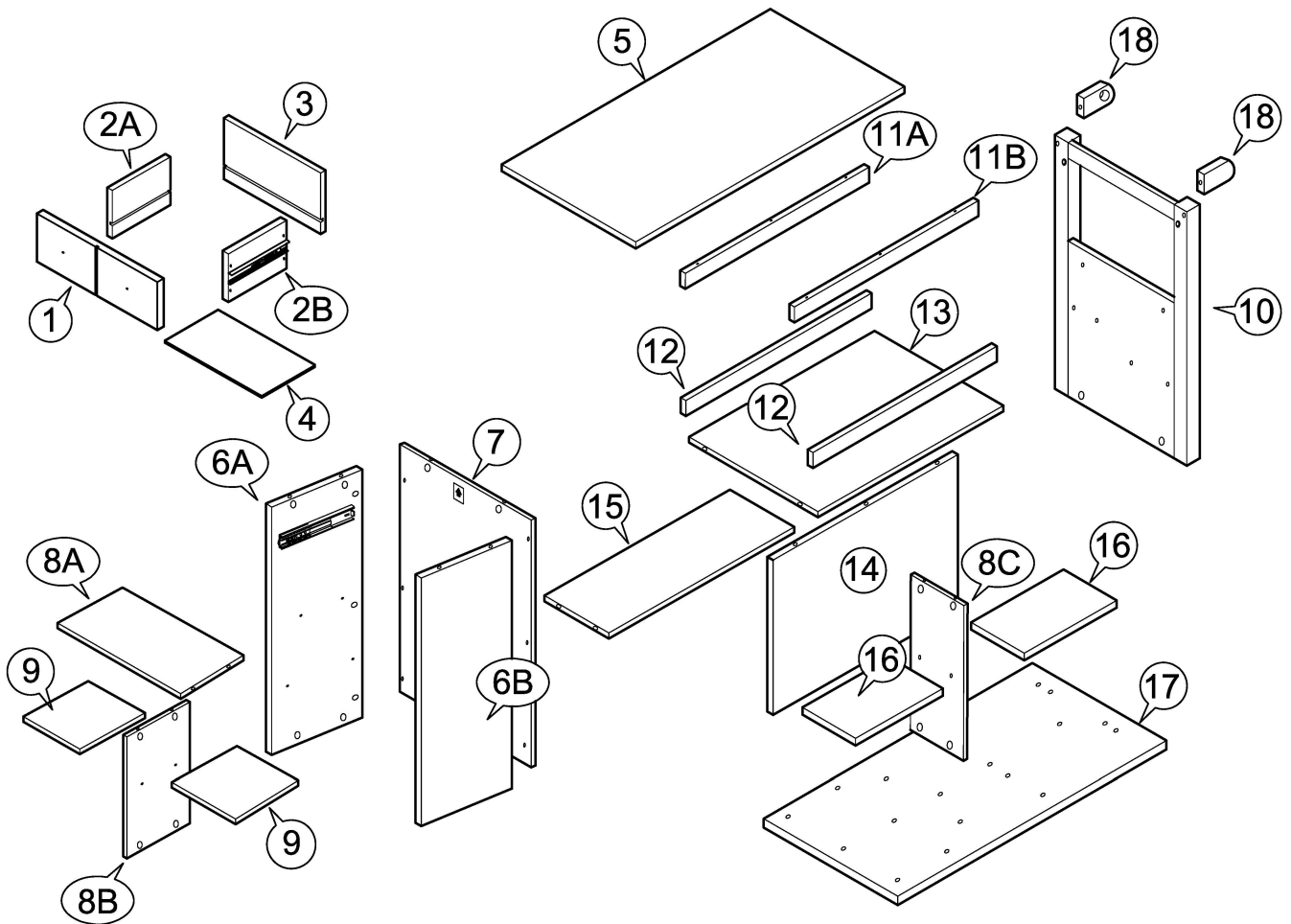





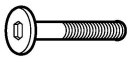

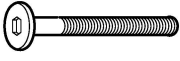
Part#	Description	Qty
12	Middle Apron	2pcs
13	Middle Base Panel	1pc
14	Lower Divide Panel	1pc
15	Shelf - D	1pc
16	Shelf - B	2pcs
17	Bottom Panel	1pc
18	Hanger Holder	2pcs

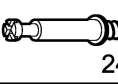
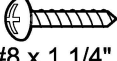
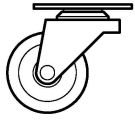
PARTS ASSEMBLY OVERVIEW

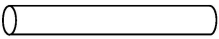

ASSEMBLY INSTRUCTIONS

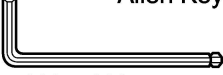
Hardware List

DESCRIPTION	QTY	EXTRA	DESCRIPTION	QTY	EXTRA	DESCRIPTION	QTY	EXTRA
A  Bolt M6 x 60mm-BLK	2	2	G  Knob Handle	2	-	M  Ø14.5 Plug	2	2
B  Bolt M6 x 70mm	2	2	H  Screw 20mm	2	-	N  Castor with Brake 50mm	2	-
C  Cam-Bolt 24mm	46	2	I  Screw #8 x 1 1/4"	20	2	O  Castor 50mm	2	-
D  Cam-lock 12mm	46	2	J  Screw M3.5 x 16mm	20	2	P  Hanger Rod 409 x 25 Ømm	1	-
E  Barrel Nut M6 x 13mm	2	2	K  Shelf Holder	16	2	Q  L - Bracket 20 x 20mm - RB	2	-
F  Wood Dowel M8 x 30mm	2	2	L  Allen Key M4 x 110mm	1	-	R  Cap	26	2

* Extra hardware for spare use

Instructions For Fastening CAM-BOLT and CAM-LOCK

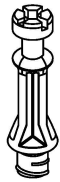

CAM-BOLT

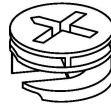

CAM-LOCK

INSERTING AND TIGHTENING CAM-BOLT

Insert Cam-bolt into the pre-drilled hole. Use a Phillips Screwdriver to tighten until shoulder is snug and flushed with the panel. See illustrations below.

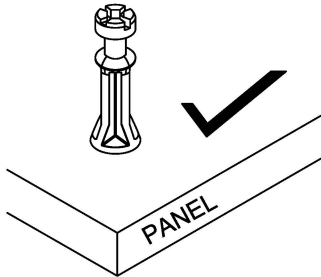
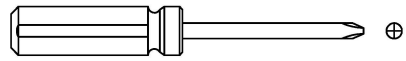

Shoulder is flushed (on the same level) with the panel.

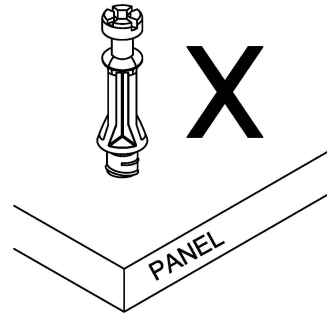
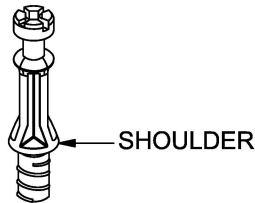

Shoulder is above the panel.

INSERTING CAM-LOCK

Align the arrow on the Cam-lock to the Cam-bolt head and insert the Cam-lock.

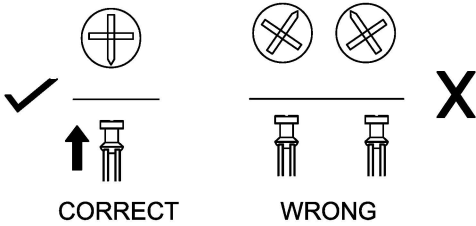

CORRECT

WRONG

TIGHTENING CAM-LOCK

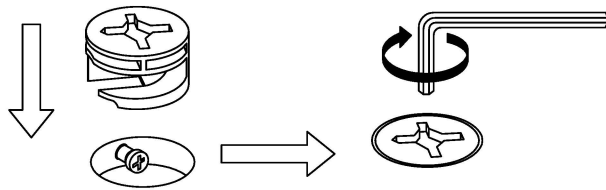

Cam-bolt head needs to be in center

Use the Allen Key to turn the Cam-lock clockwise to lock onto the head of the Cam-bolt. Turn until it is snug -- over-tightening could damage Cam-lock or/and Cam-bolt

Instructions For Installing Barrel Nut

Insert Barrel Nut with the perpendicular hole facing and in-line with the drill hole that the bolt is to be inserted.

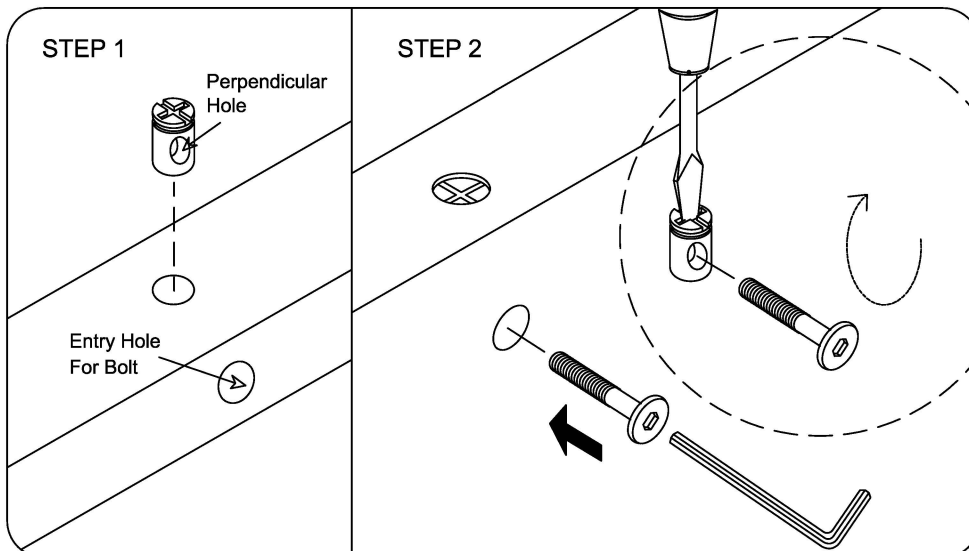

Use a Flat-head Screwdriver to hold Barrel Nut in position before inserting bolt to thread into the Barrel Nut.

ASSEMBLY INSTRUCTIONS

STEP 1

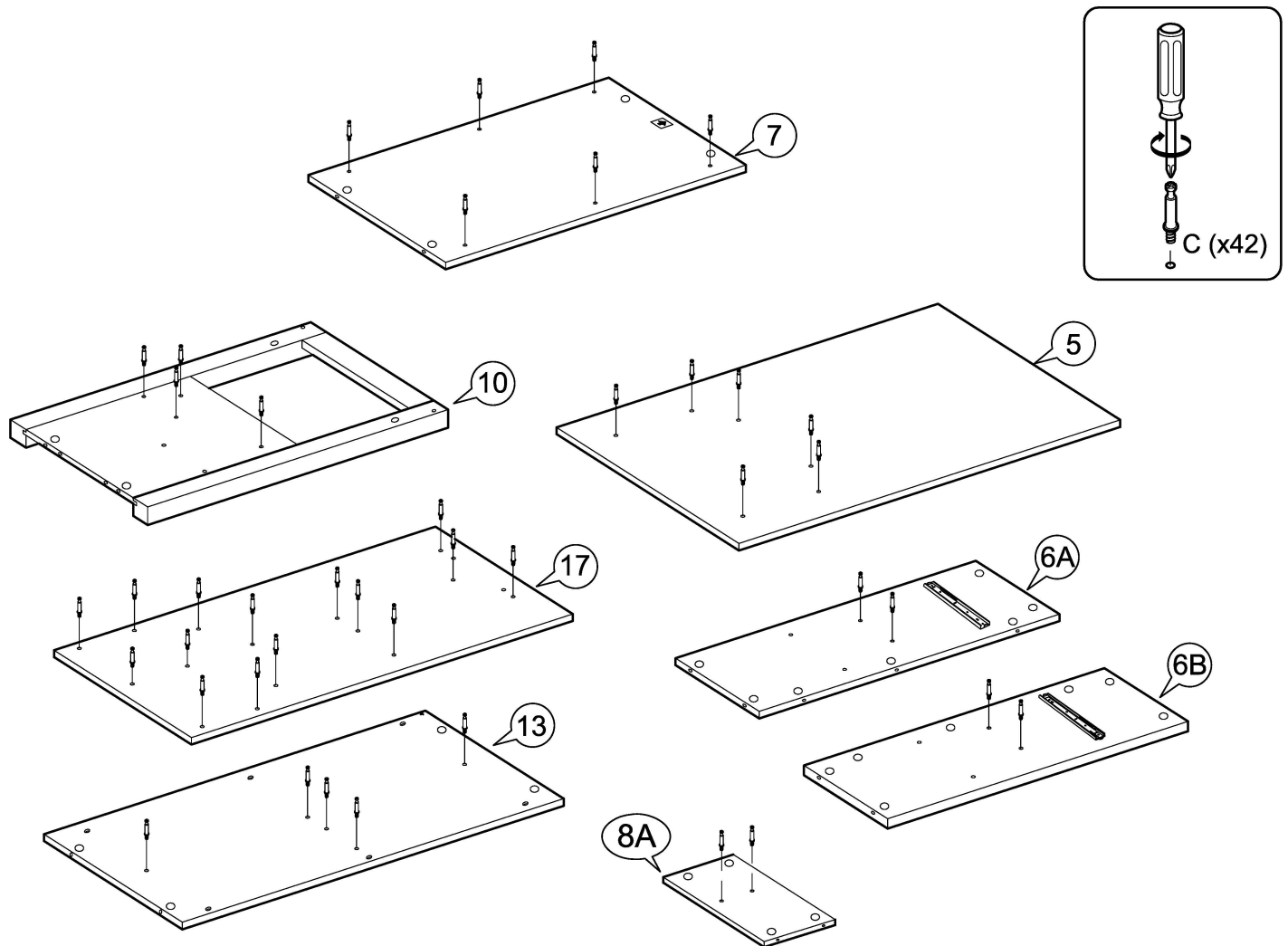

a) Lay Left Frame Panel (7) flat down on a material that does not scratch or damage the part, and screw in 6 pieces of Cam-bolt (C) into the designated holes as shown in the drawing on the left. Refer to page 4 for instructions on inserting and tightening cam-bolts.

b) Lay the following parts flat down on a material that does not scratch or damage the parts: Top Panel (5), Left & Right Side Panel (6A & 6B), Shelf-A (8A) Middle Base Panel (13), Bottom Panel (17), and Right Frame (10), and screw in Cam-bolt (C) into the designated holes.

ASSEMBLY INSTRUCTIONS

STEP 2

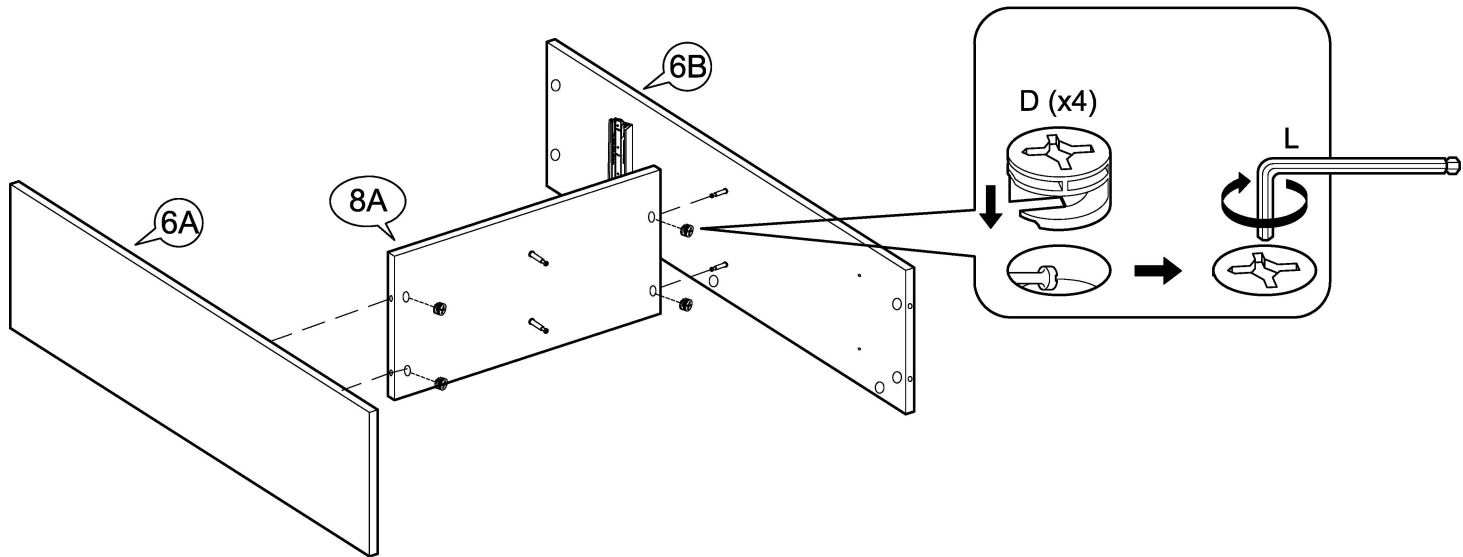

- Attach Shelf-A (8A) to Left & Right Side Panel (6A & 6B) via cam-bolts on (6A & 6B). Note the orientation of the parts.
- Insert Cam-lock (D) into designated holes on (8A) and turn clockwise to lock onto cam-bolt. Refer to Page 4 for instructions on inserting and tightening cam-locks

STEP 3

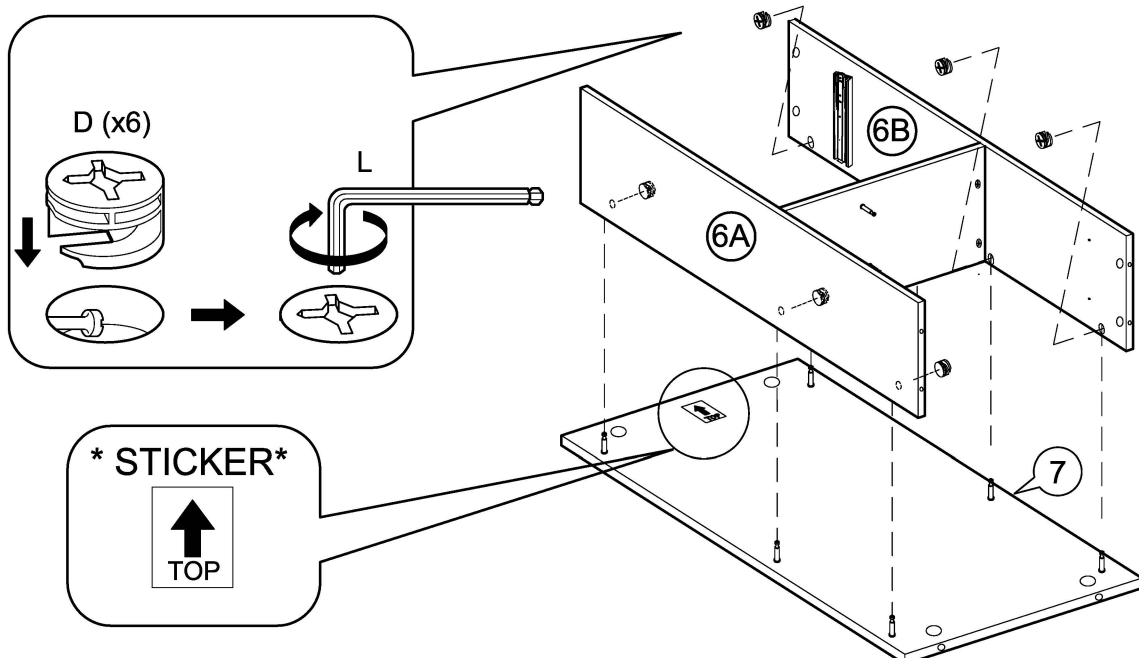

- Lay Left Frame Panel (7) on a material that does not scratch or damage the part. Note the orientation of the part with respect to the sticker.
- Attach the assembly from STEP 2 to (7) via cam-bolts on (7).
- Insert Cam-lock (D) into designated holes on 6A & 6B, then turn clockwise to lock onto cam-bolt on (7).

ASSEMBLY INSTRUCTIONS

STEP 4

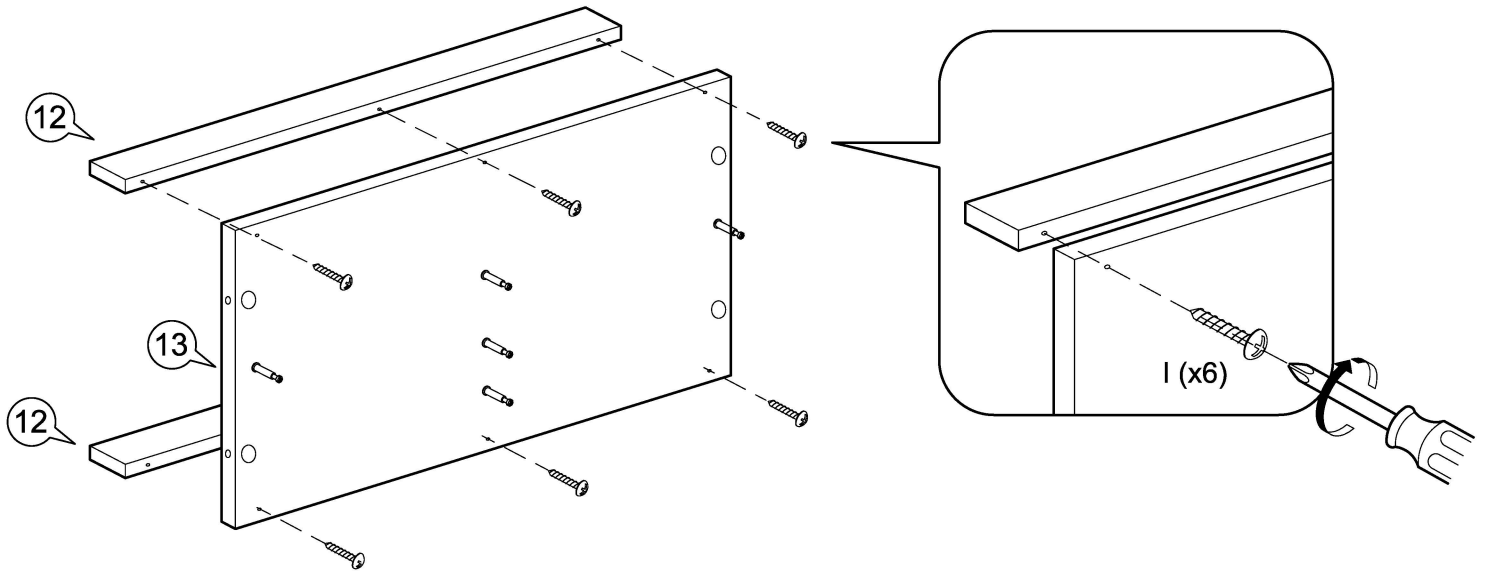

Position Middle Base Panel (13) and Middle Apron (12) as shown and align the screw holes on each part. Use Screw (I) to fasten (12) to (13). Do not tighten the screws completely until all 3 screws are in place on (12).

STEP 5

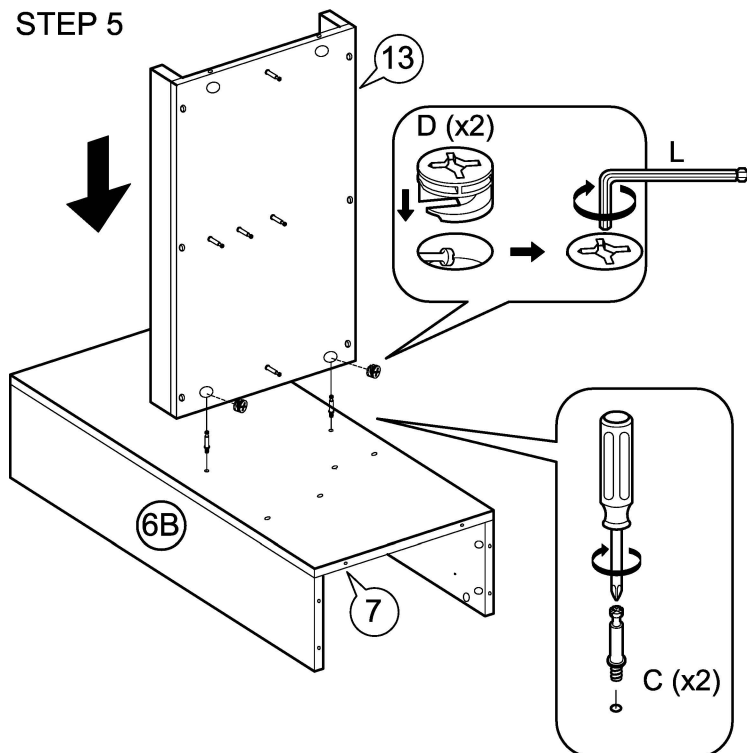

- Position the Left Frame (7) assembly from STEP 3 as shown, and attach the Middle Base Panel/Apron assembly from STEP 4 via Cam-bolts on (7).
- Insert Cam-lock (D) into designated holes on (13), then turn clockwise to lock onto cam-bolt on (7)

STEP 6

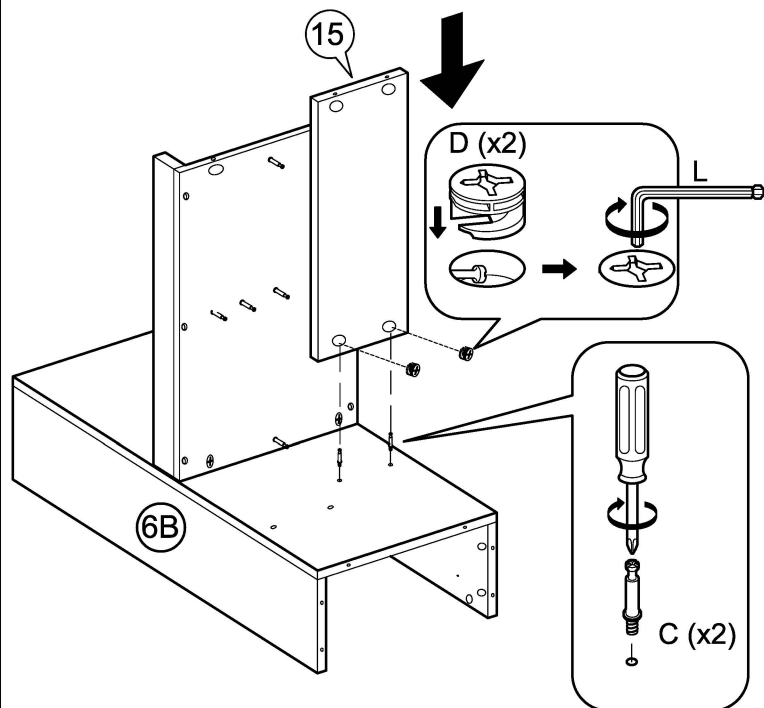

- Attach the Shelf-D (15) via Cam-bolts on (7).
- Insert Cam-lock (D) into designated holes on (15), then turn clockwise to lock onto cam-bolt on (7).
- Set the assembly aside.

ASSEMBLY INSTRUCTIONS

STEP 7

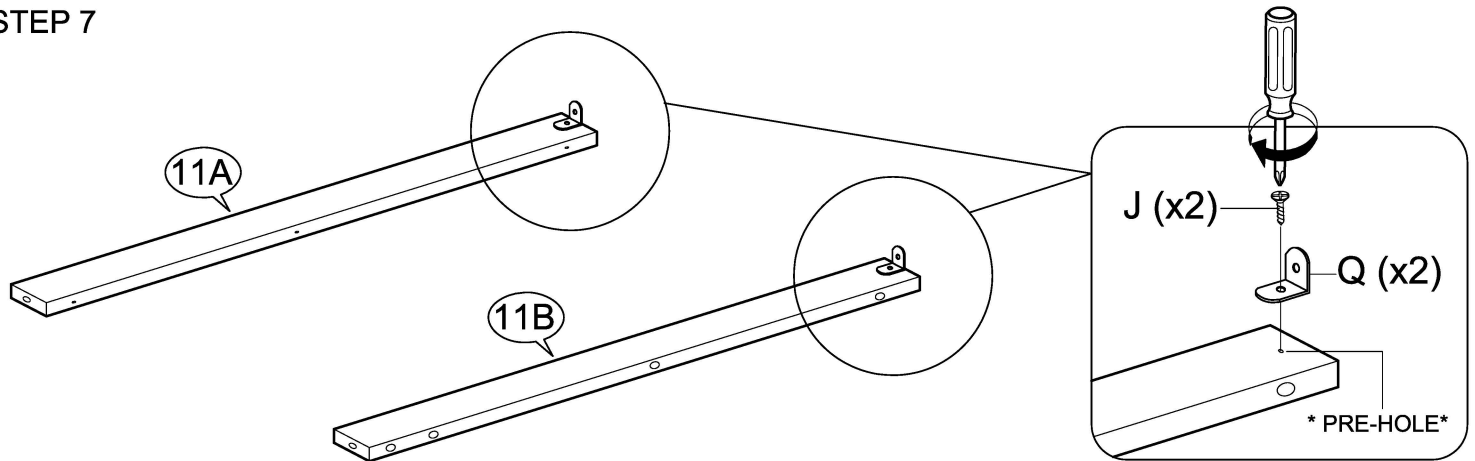

Use Screw (J) to fasten L-Bracket (Q) to Top Rear Apron (11A) and Top Front Apron (11B).

STEP 8

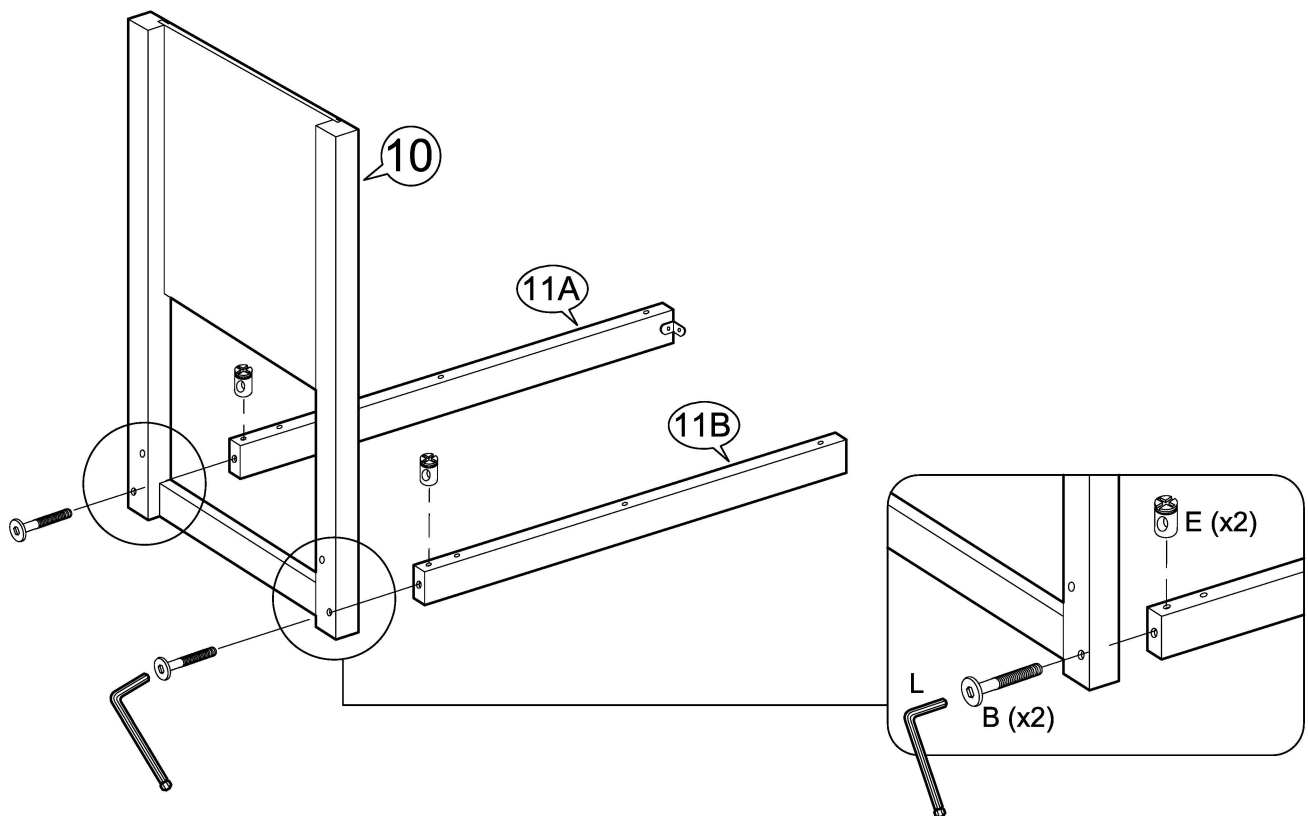

- With assistance, position Right Frame (10) bottom-side up as shown.
- Align the designated screw holes on Top Rear and Front Apron (11A & 11B) to those on (10).
- Insert Barrel Nut (E) into the holes on (11A & 11B) as shown.
Refer to Page 4 for instructions on installing Barrel Nut.
- Insert Bolt (B) through the designated holes on (10) into the hole (11A & 11B) to screw into the inserted Barrel Nut. Do not tighten the bolt completely until both bolts are in place.

ASSEMBLY INSTRUCTIONS

STEP 9

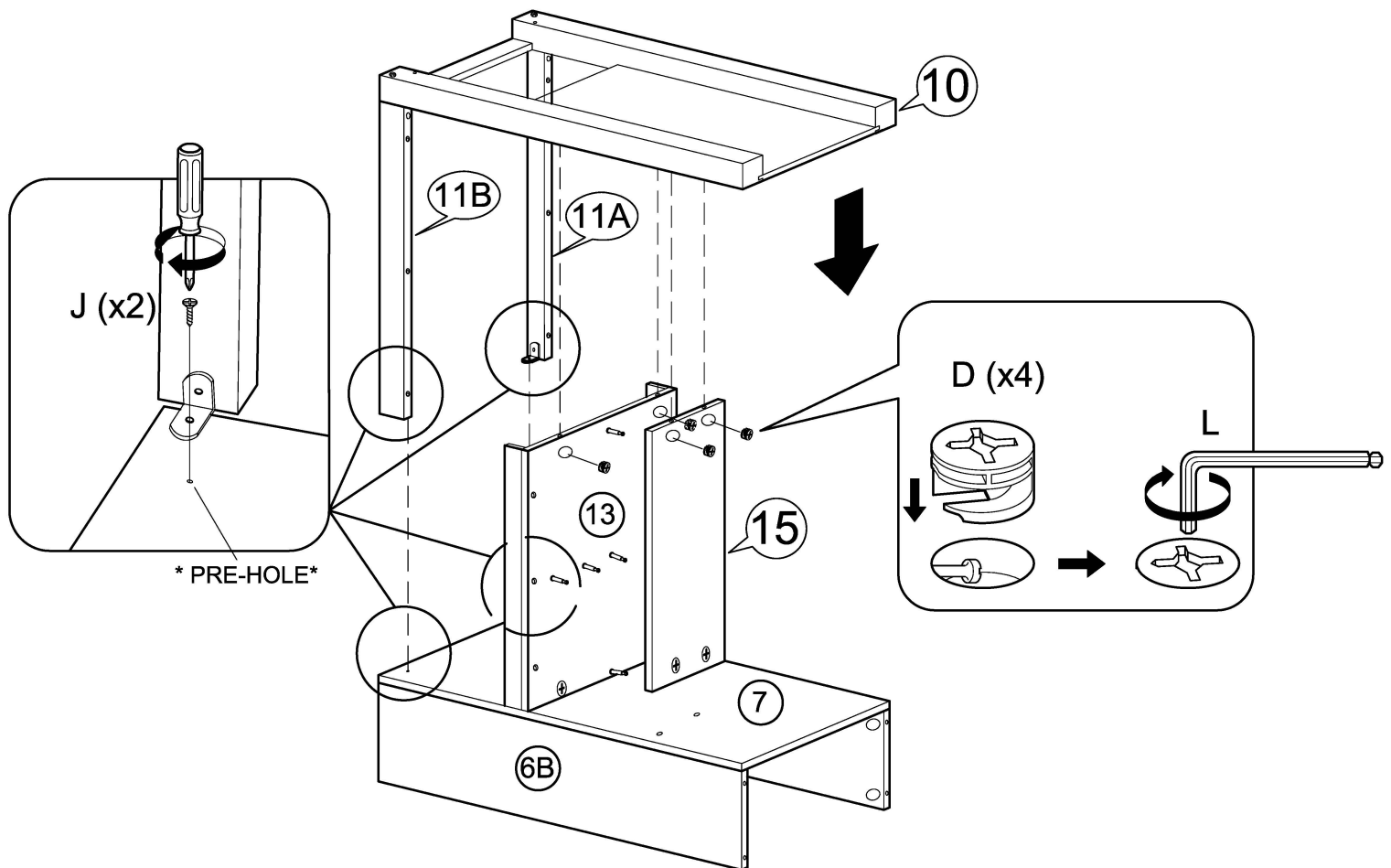

- Attach the assembly in STEP 8 to the assembly completed in STEP 6 by fitting the cam-bolts on (10) to the bolt holes on the top edge of (13) and (15) as shown.
- Locate pilot holes on (7) for Screw (J). Use a Phillips screwdriver to drive (J) to fasten L-Bracket on (11A and 11B) to (7).
- Insert Cam-lock (D) into designated holes on (13) and (15), then turn clockwise to lock onto cam-bolt on (10).

ASSEMBLY INSTRUCTIONS

STEP 10

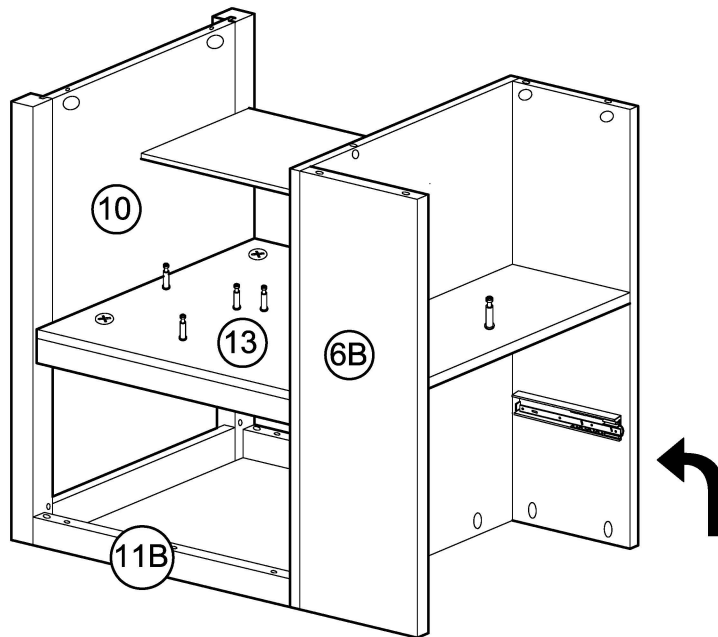

With assistance, position the assembly from STEP 9 as shown.

STEP 11

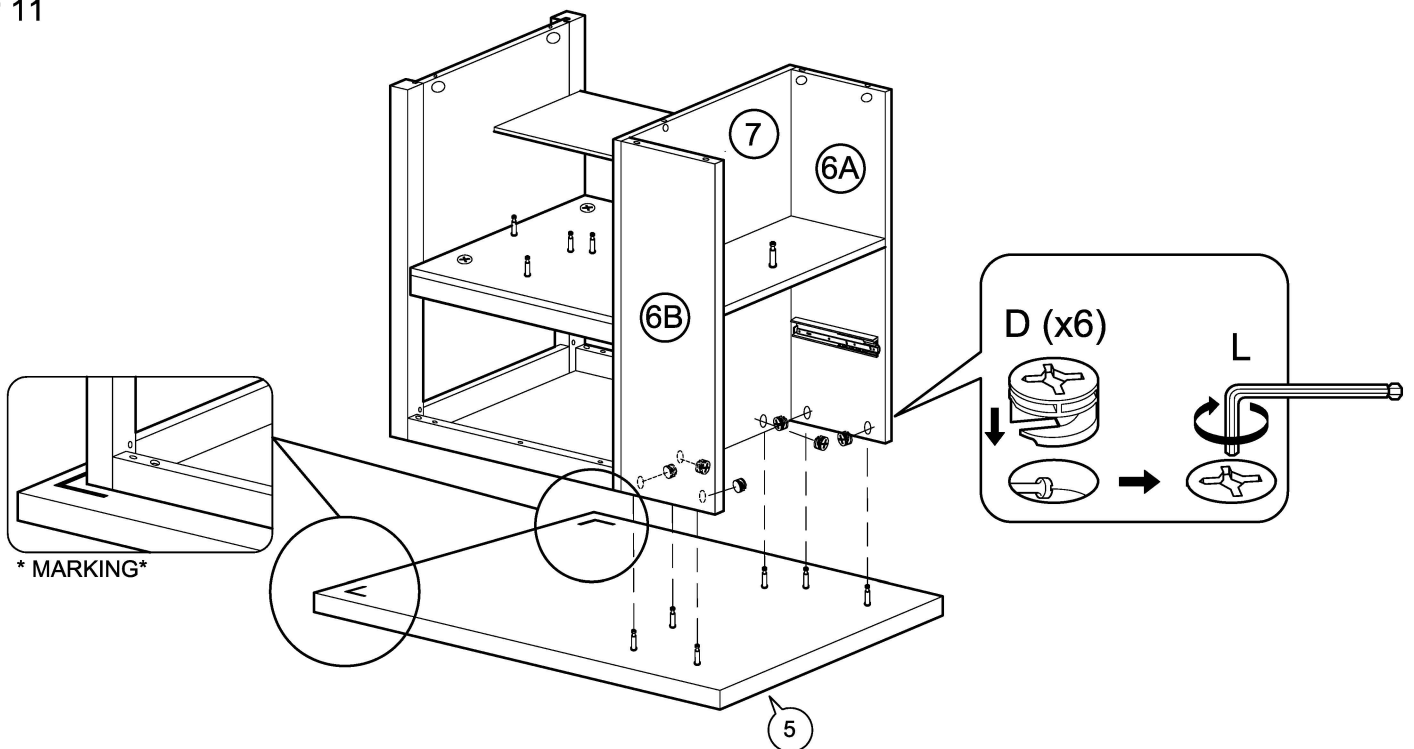

- Lay Top Panel (5) with the cam-bolts facing up as shown up on a material that does not scratch or damage the part.
- With assistance, position the assembly in STEP 10 directly over (5) to attach Left and Right Panel (6A & 6B) and Left Frame Panel (7) to (5) via cam-bolts.
- Insert Cam-lock (D) into designated holes on (6A & 6B) and (7), then turn clockwise to lock onto cam-bolt on (5).

ASSEMBLY INSTRUCTIONS

STEP 12

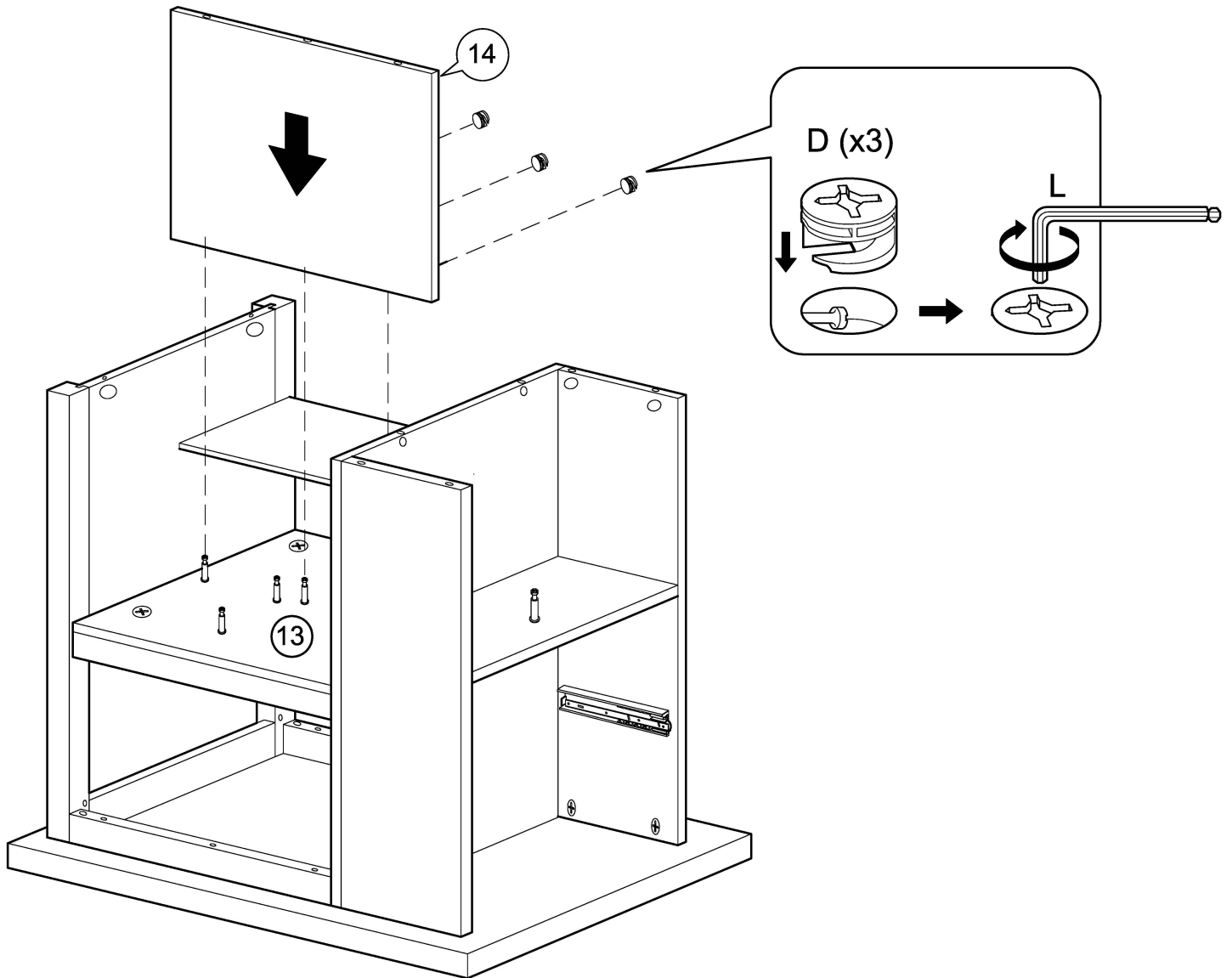

- Attach Lower Divide Panel (14) to Middle Base Panel (13) via Cam-bolts on (13).
- Insert Cam-lock (D) into designated holes on (14), then turn clockwise to lock onto cam-bolt on (13).

ASSEMBLY INSTRUCTIONS

STEP 13

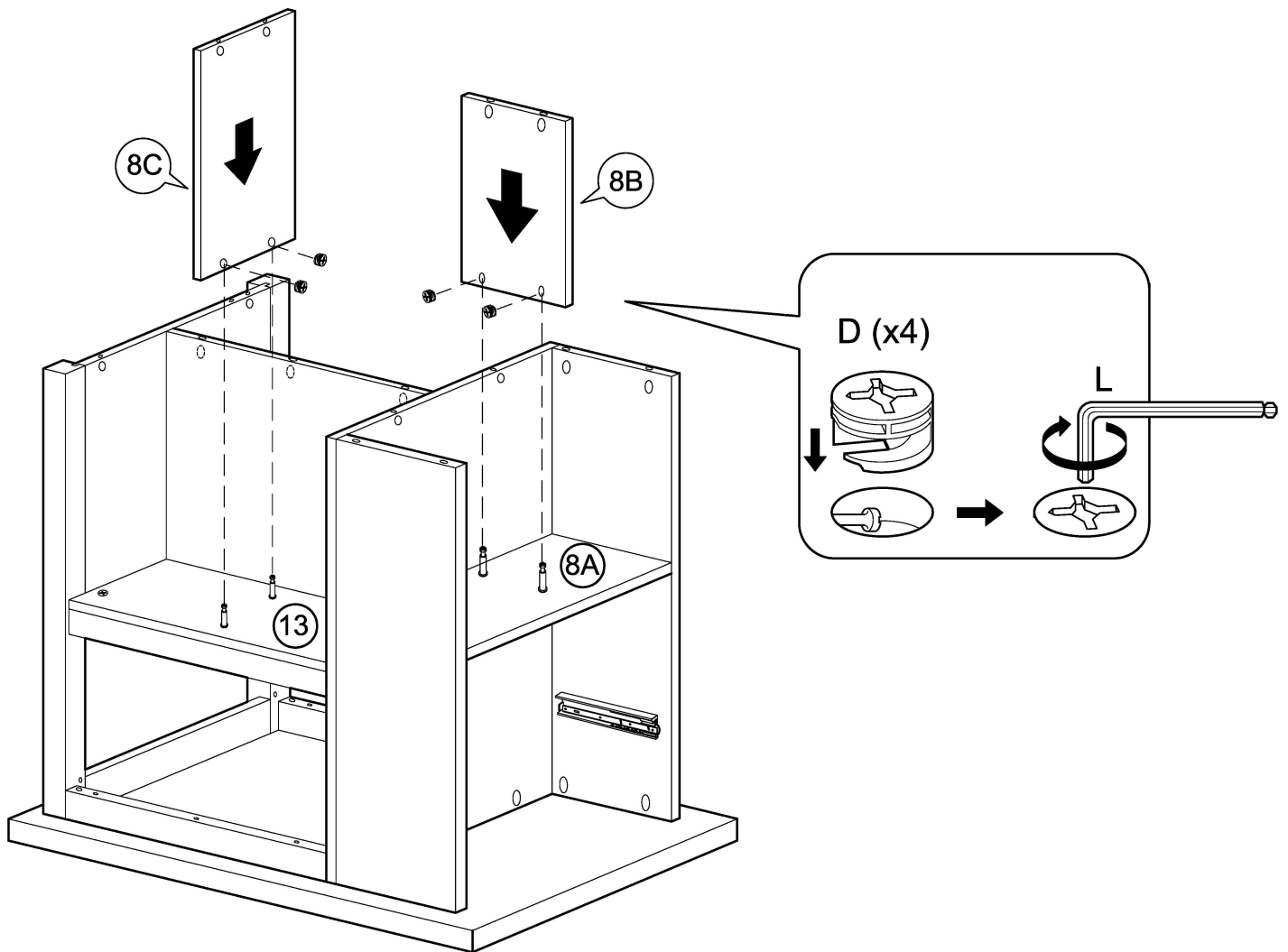

- a) Attach Side Divide Panel (8B) to Shelf-A (8A), and Front Divide Panel (8C) to Middle Base Panel (13) via Cam-bolts on (8A) and (13), respectively.
- b) Insert Cam-lock (D) into designated holes on (8B & 8C), then turn clockwise to lock onto cam-bolts on (8A) and (13).

ASSEMBLY INSTRUCTIONS

STEP 14

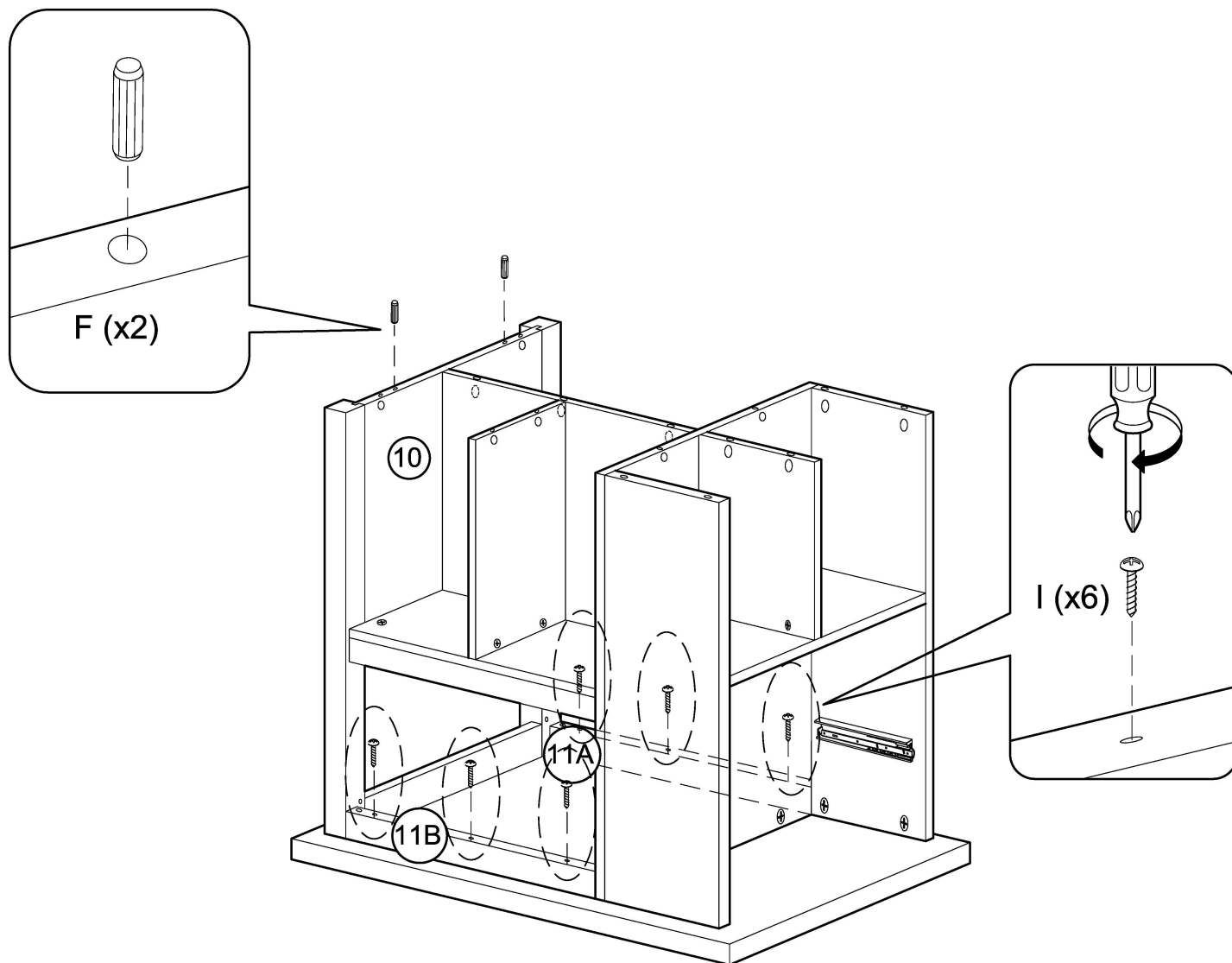

- a) Use Screw (I) to fasten Top Rear Apron (11A) and Top Front Apron (11B) to Top Panel.
- b) Insert Wood Dowel (F) into the inner two holes on the top edge of Right Frame (10) as shown.

ASSEMBLY INSTRUCTIONS

STEP 15

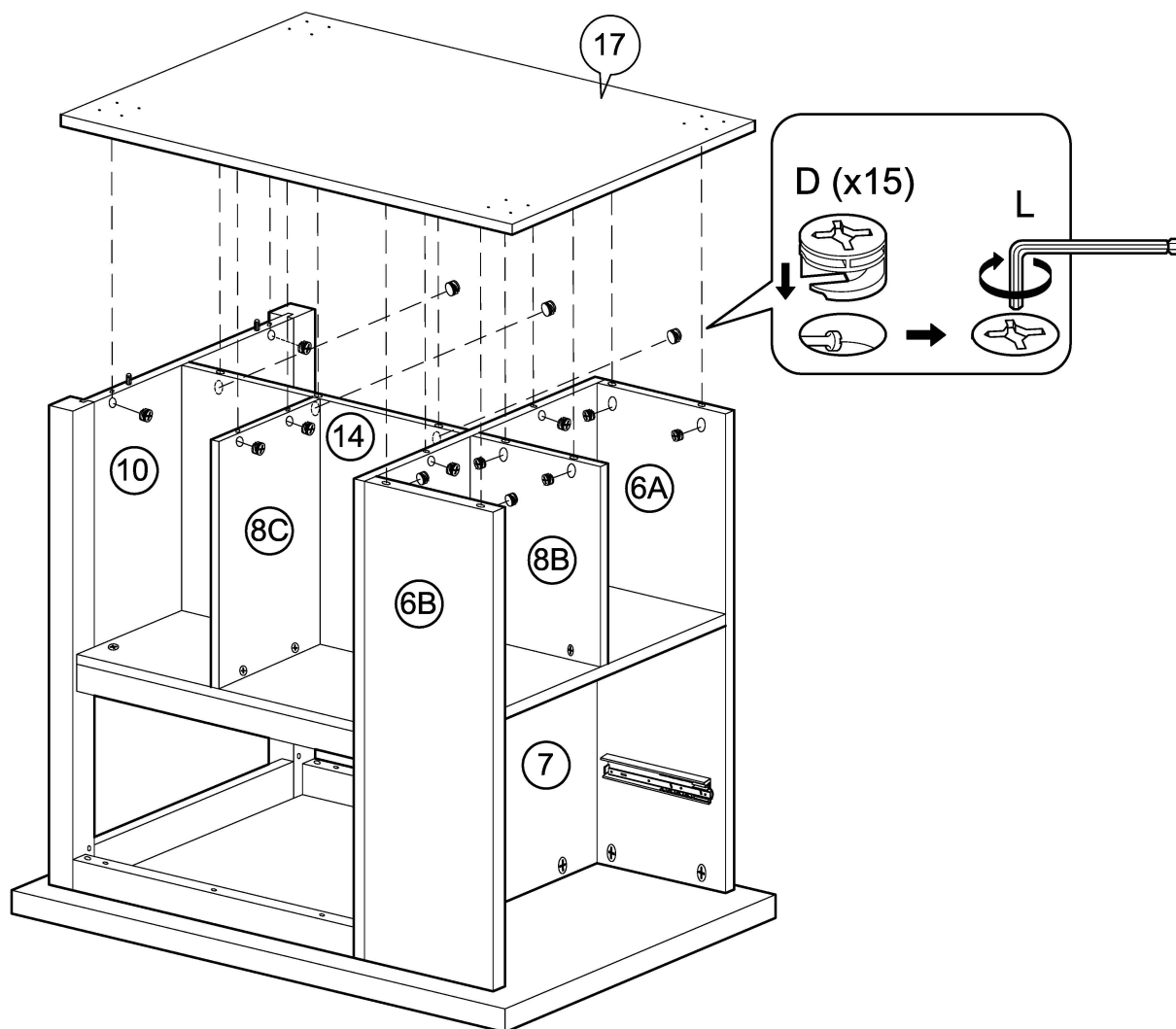

- Attach Bottom Panel (17) by fitting the cam-bolts on (17) to the respective holes on the top edge of (10, 14, 8C, 7, 8B, 6A & 6B).
- Insert Cam-lock (D) into the designated holes on (10, 14, 8C, 7, 8B, 6A & 6B) and turn clockwise to lock onto cam-bolt on (17).

ASSEMBLY INSTRUCTIONS

STEP 16

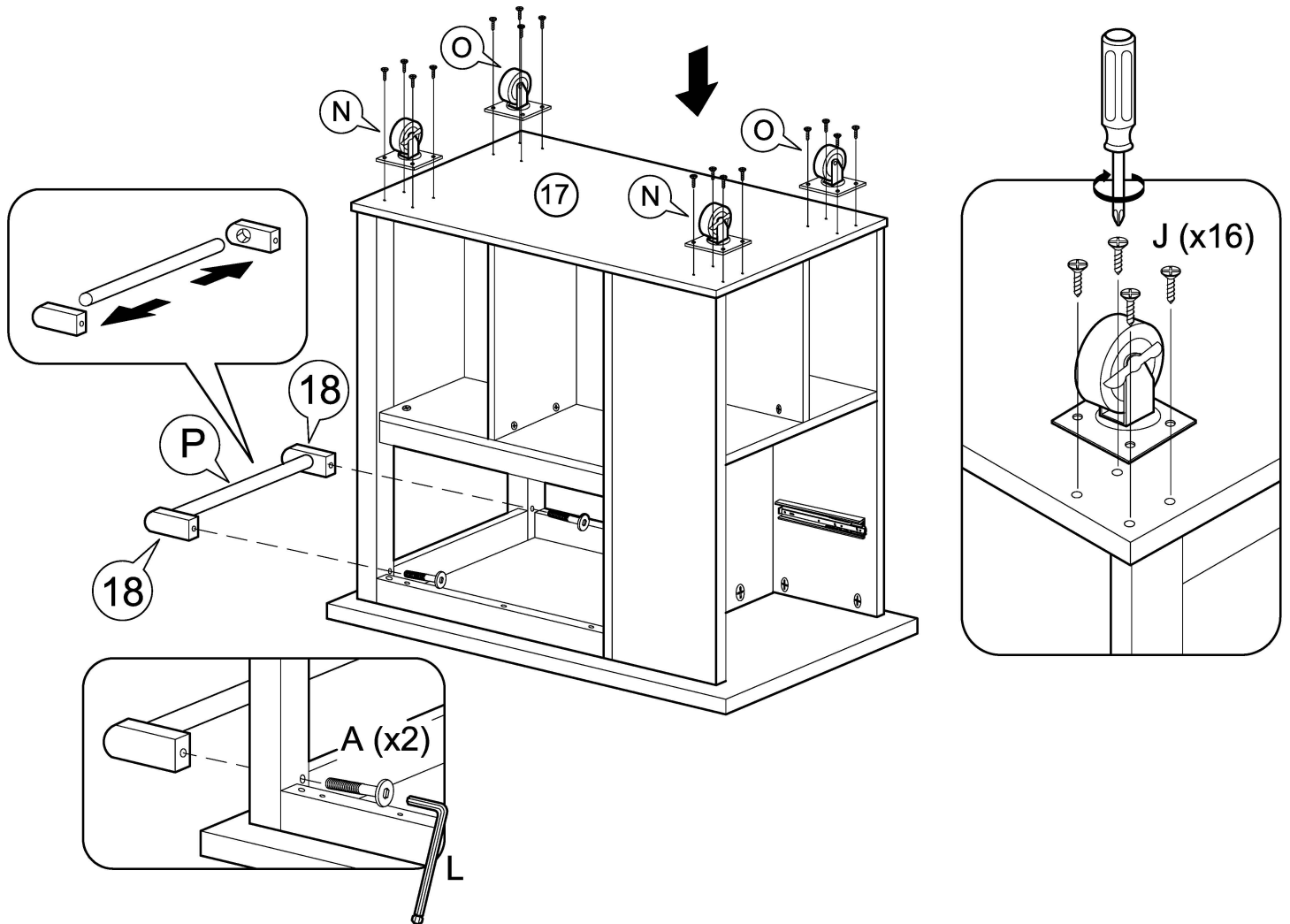

- a) Align the screw holes on Castor (N & O) to the pilot holes on Bottom Panel (17), and use Screw (J) to fasten. Do not tighten the screws completely until all 4 screws are in place on each Castor.
- b) Fit Hanger Rod (P) between Hanger Holder (18) and use Bolt (A) to fasten (18) to Right Frame.

ASSEMBLY INSTRUCTIONS

STEP 17

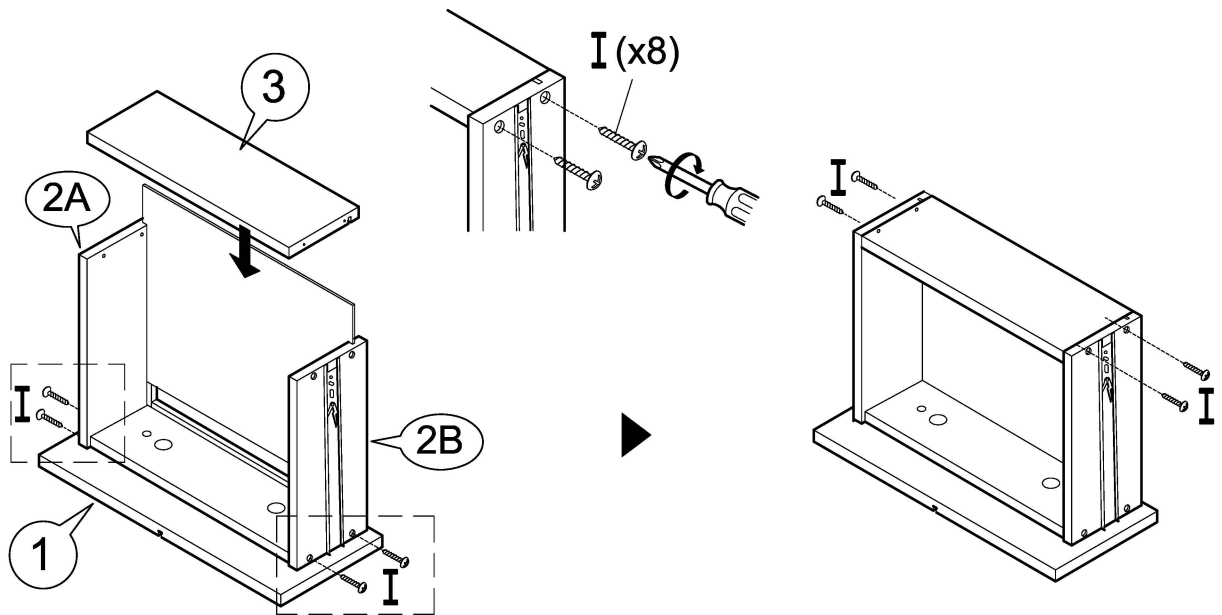

- Place Drawer Front Panel (1) with interior side facing up, as shown, on a material that does not scratch its exterior surface.
- Position Drawer Left & Right Panels (2A & 2B) to (1) as shown - note the groove alignment on each panel. Use Phillips Screwdriver to drive Screw (I) to fasten side panels to front panel. Do not tighten screws completely until both screws are in each panel.
- Fit Drawer Bottom Panel (4) by inserting the edge of (4) into the groove on Drawer Side and Front Panels.
- Fit Drawer Back Panel (3) between (2A) and (2B), and check that the top edge of (4) fit into the groove on the bottom side of (3). Use Screw (I) to fasten (3) to (2A) and (2B).

STEP 18

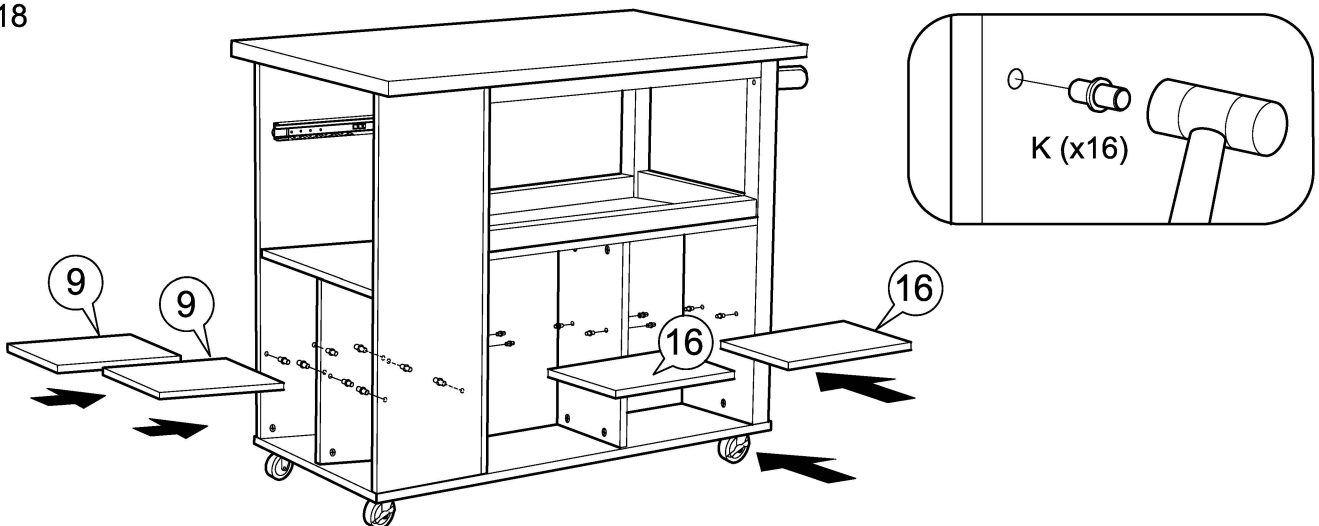

- Insert Shelf Holder (K) into designated holes as shown. Use a mallet to lightly tap in (K) if necessary.
- Place Shelf-C (9) and Shelf-B (16) to sit on Shelf Holder (K).

ASSEMBLY INSTRUCTIONS

STEP 19

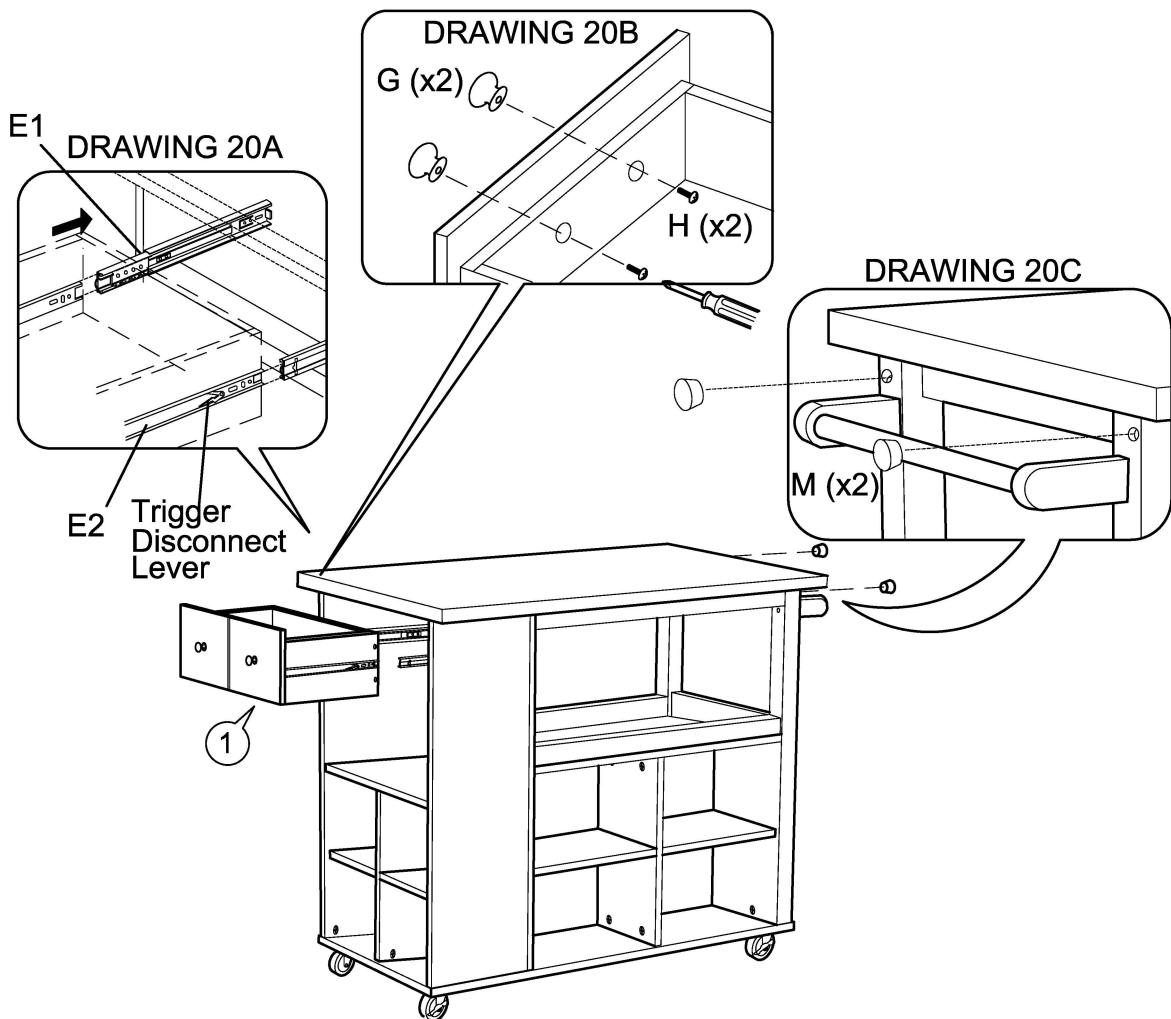

a) Insert Drawers - Refer to Drawing 20A

- i) On the Left & Right Side Panel of the cart, bring the ball-bearing slider on Slide Track (E1) forward to the front edge of (E1) (towards drawer opening of the cart).
- ii) Align the back open-end of the Slide Runner (E2) on each side of the drawer to fit squarely into the groove on the open front-end of (E1) on the Left & Right Side Panel. Be sure the drawer/(E2) is not tilted or angled, and push in drawer squarely.
- iii) When the drawer is pushed in about half way, the Trigger Disconnect Lever on (E2) will be engaged onto (E1) which will create a slight resistance - this is normal. Pull out the drawer a little bit and gently push in the drawer again to engage the Trigger Disconnect Lever to the slide mechanism on (E1). The drawer should now slide smoothly
- iv) If the drawer cannot be pushed in or stuck, do not force it in. Remove the drawer and repeat the steps above.
(Note: To Remove Drawers - Slide out (E2) from (E1) until Trigger Disconnect Lever is visible. Next, depress the Disconnect Lever in the groove of (E2) and at the same time slide out (E2) completely from (E1).

b) Affix Knob Handle - Refer to Drawing 20B

Use Screw (H) to affix Knob Handle (G) to Drawer Front Panel.

c) Conceal Bolt Holes - Refer to Drawing 20C

Use Plug (M) to conceal bolt holes on Right Frame

ASSEMBLY INSTRUCTIONS

STEP 20

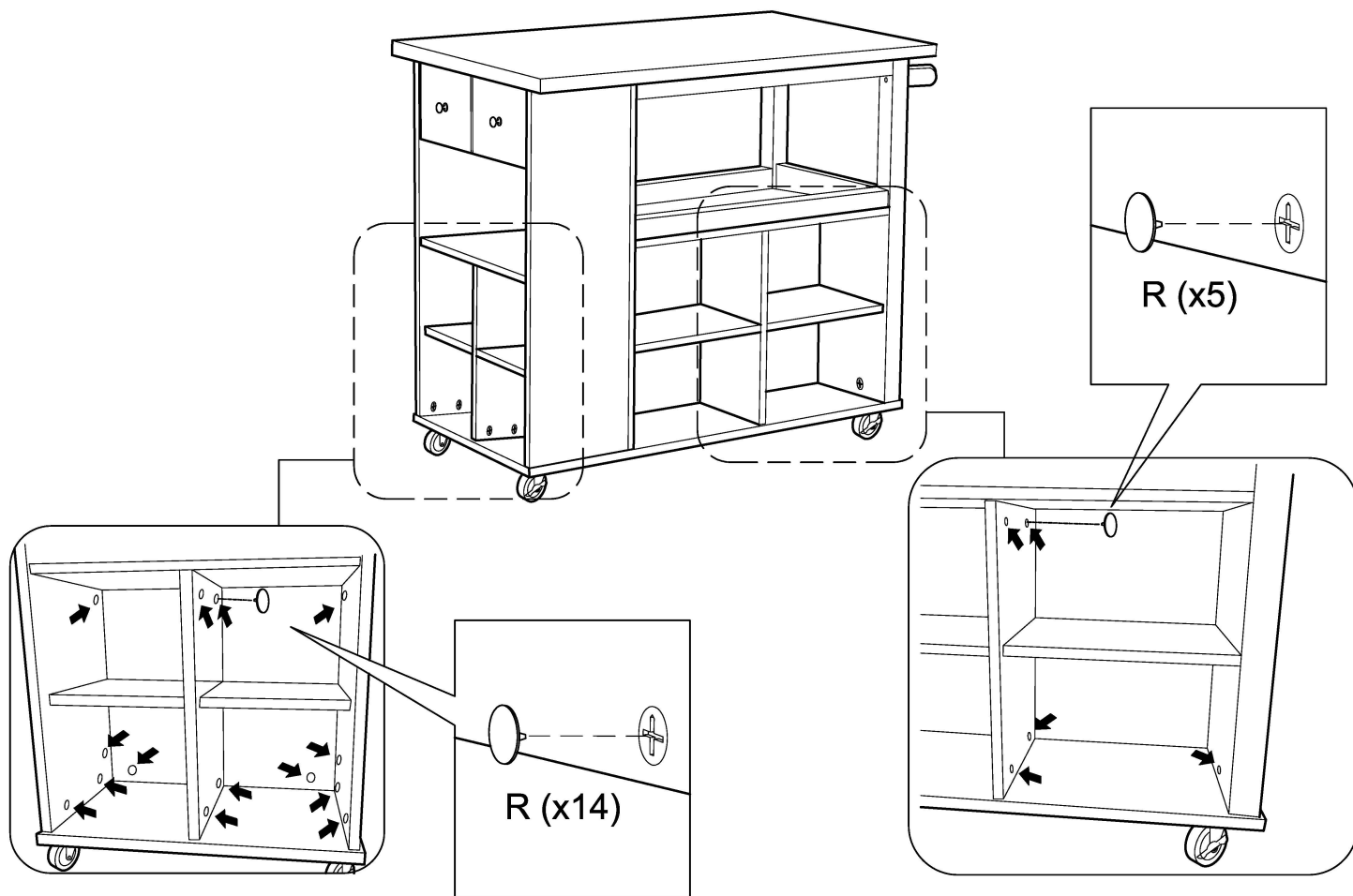

Locate the Cam-locks on the Front and Left Side of the cart, and use Cap (R) to conceal the cam-locks.

ASSEMBLY INSTRUCTIONS

STEP 21

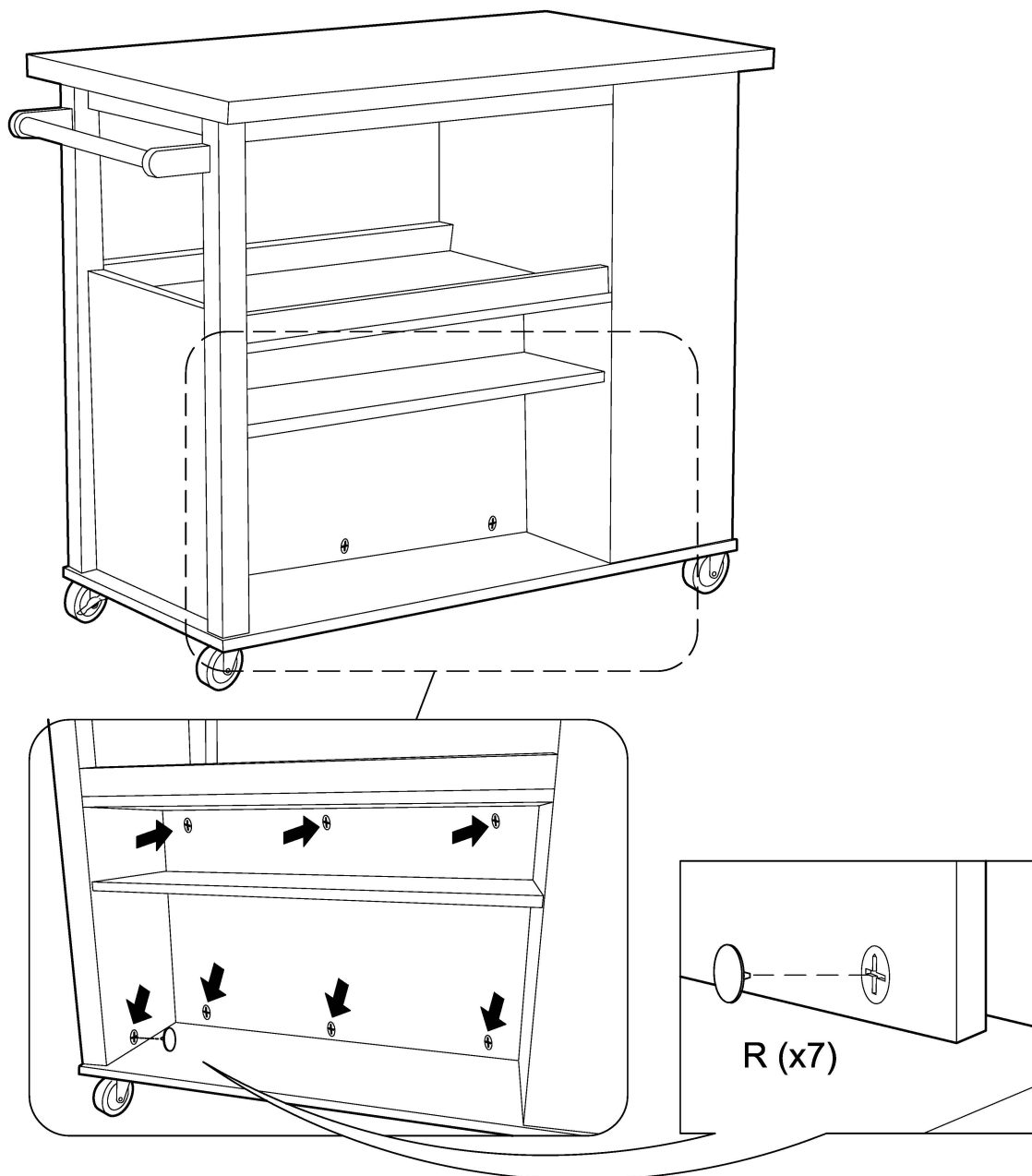

Locate the Cam-locks on the Back part of the cart, and use Cap (R) to conceal the cam-locks.

The assembly of the cart is complete.