

MADE IN CHINA

# Electric Standing Desk

Instruction Manual

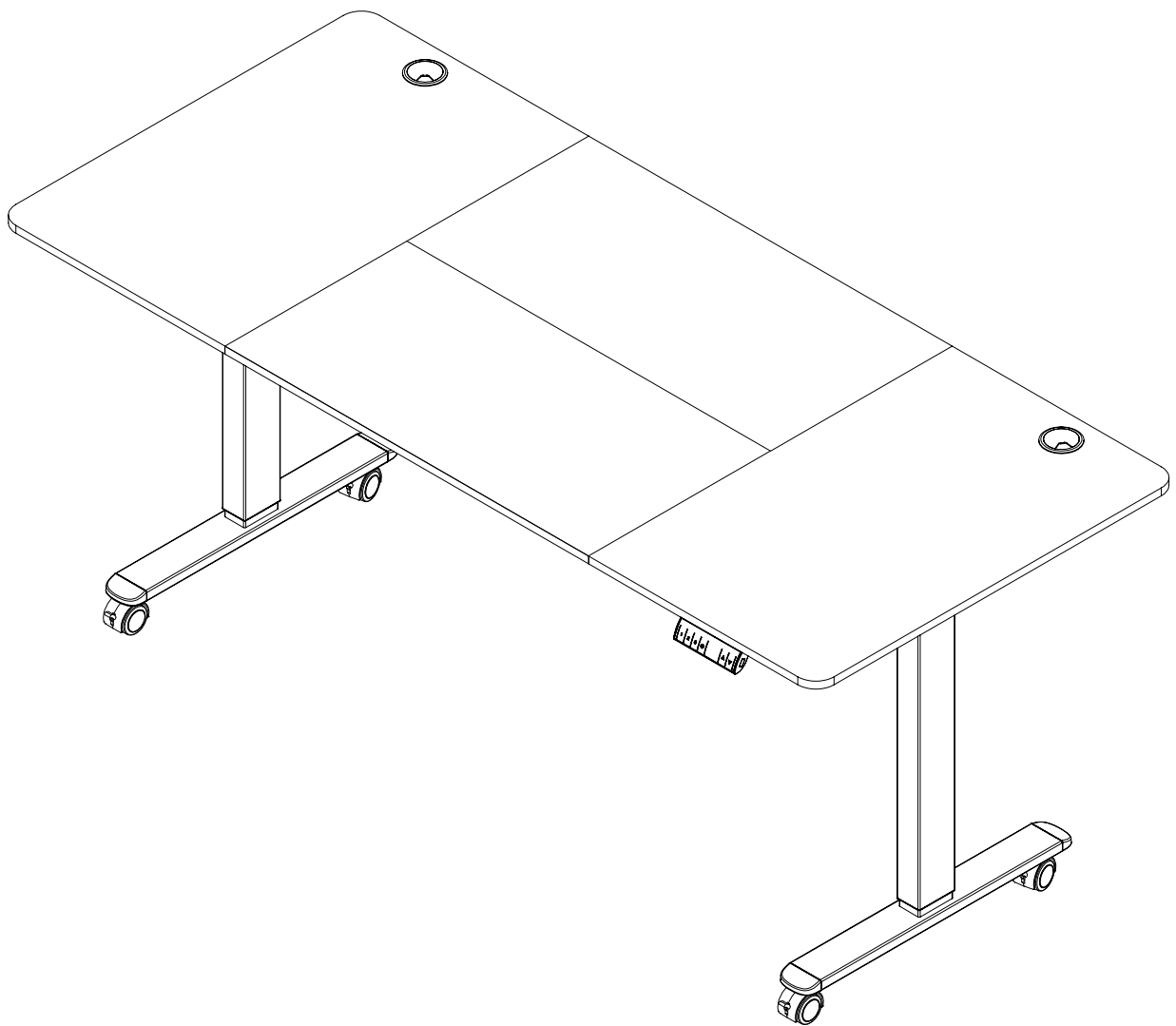

**Important-Please read these instructions before assembly.**

If you encounter any problems during installation,  
please feel free to contact us!

# Important Guidelines

Please read these instructions carefully and keep the installation manual for future reference.

When using this product, observe basic safety precautions to reduce the risk of injury:

- Ensure all hardware and parts are unpacked to verify you have all components.
- Use the tools provided in the parts package for assembly; do not use incorrect tools.
- Do not climb, stand on, or sit on the product.
- Avoid placing items on the product when moving it.
- Regularly check to ensure all bolts, screws, and brackets are securely fastened.
- Avoid placing the product in a damp environment.
- Do not store heavy objects on the product.

When not operating according to this manual, there may be potential dangers.

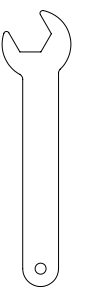
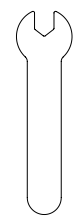
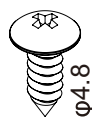
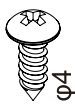
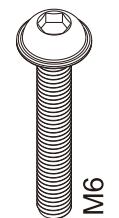
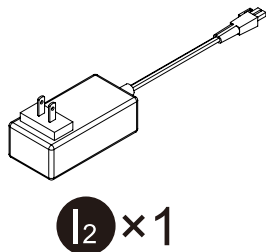
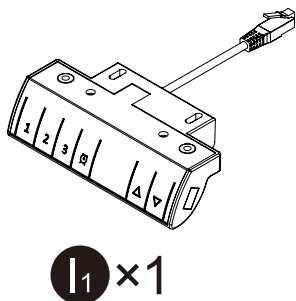
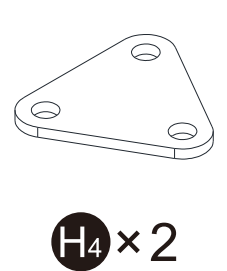
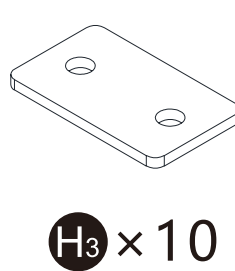
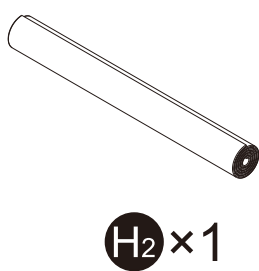
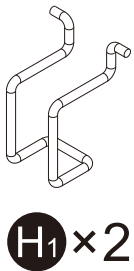
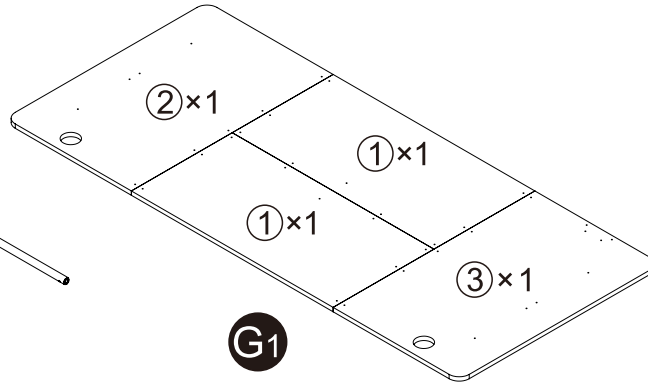
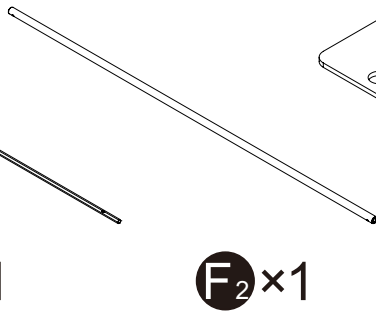
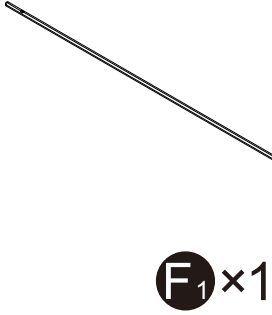
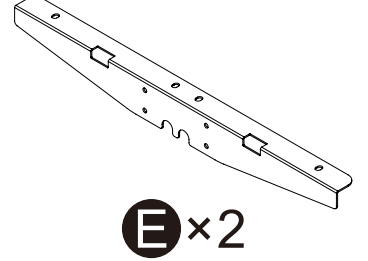
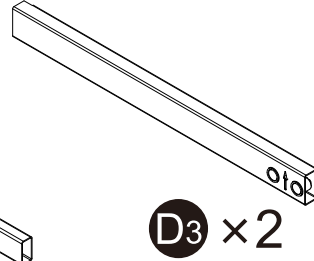
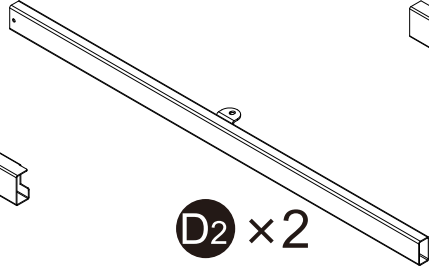
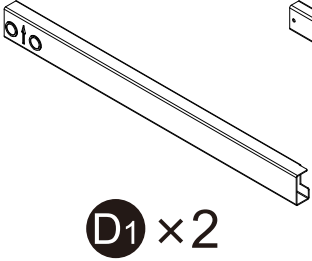
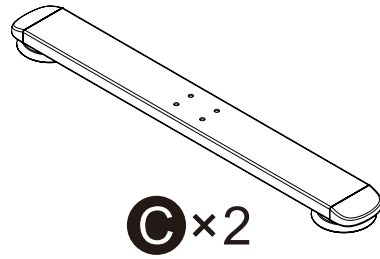
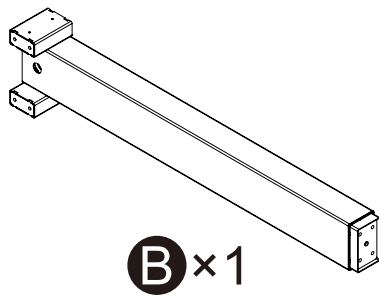
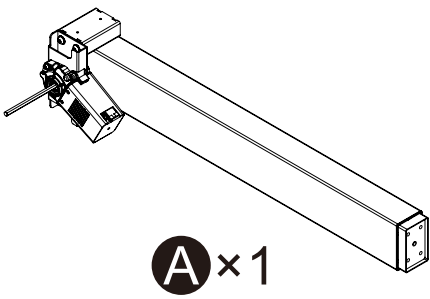

# 1

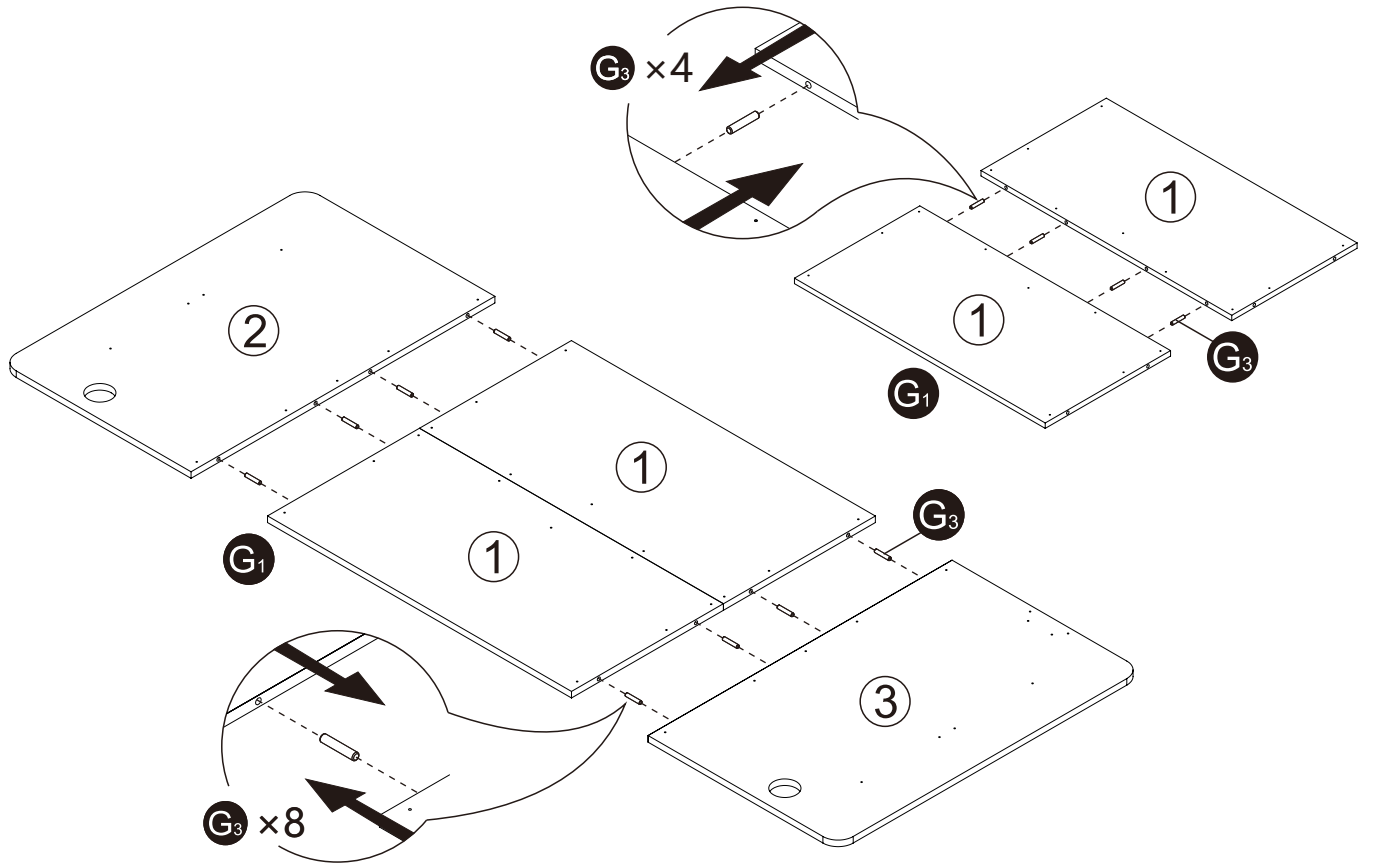

# 2

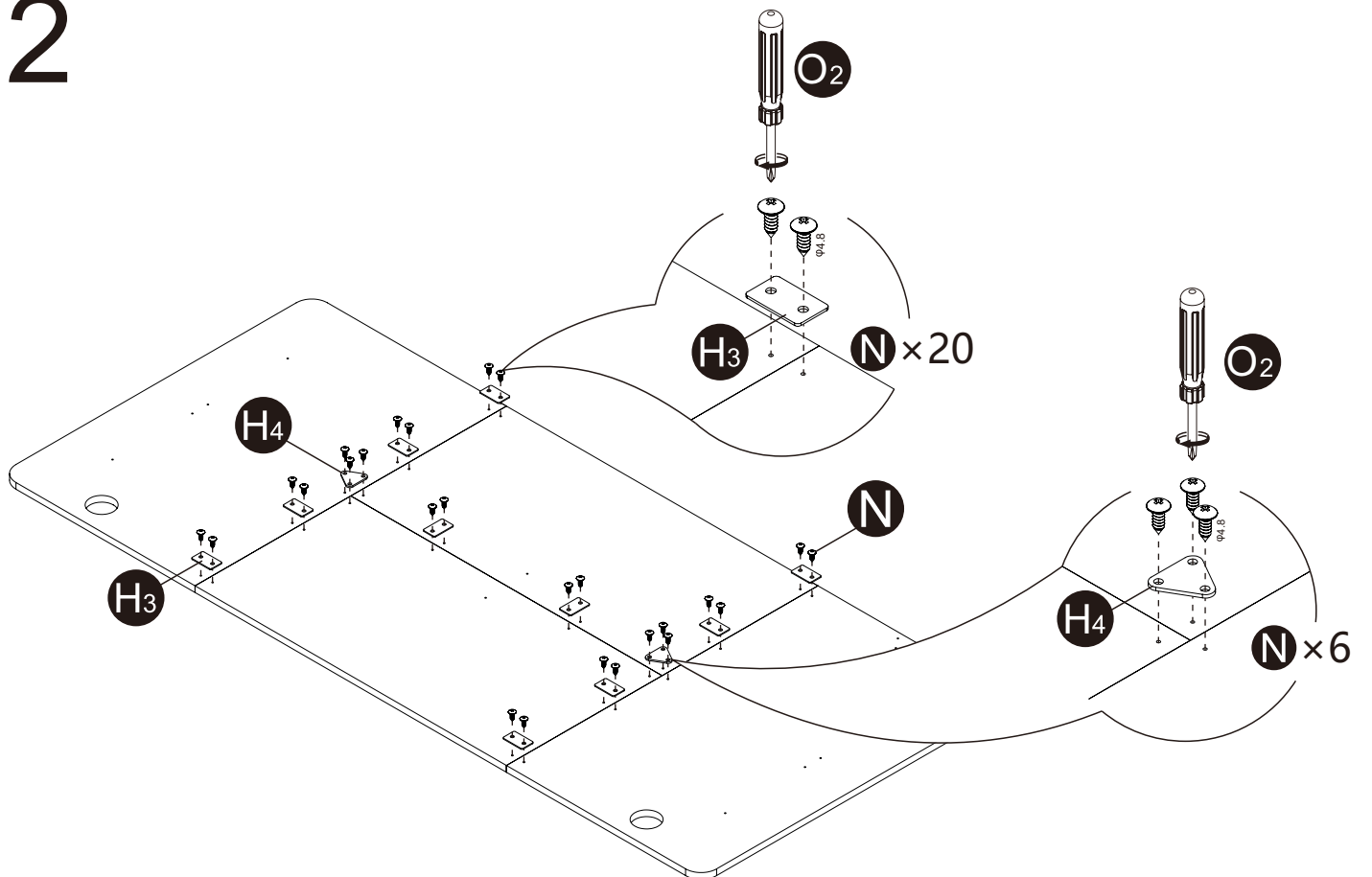

# 3

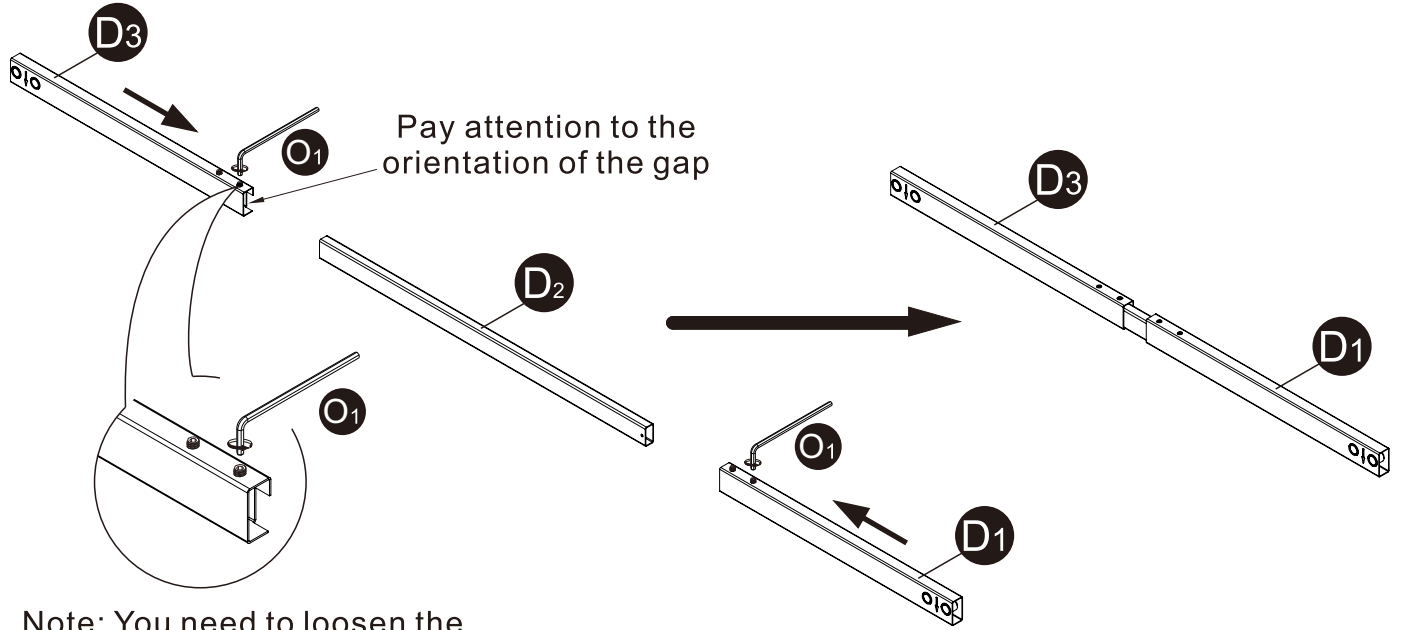

Note: You need to loosen the socket set screws on the beam first to facilitate the assembly of the beam.

# 4

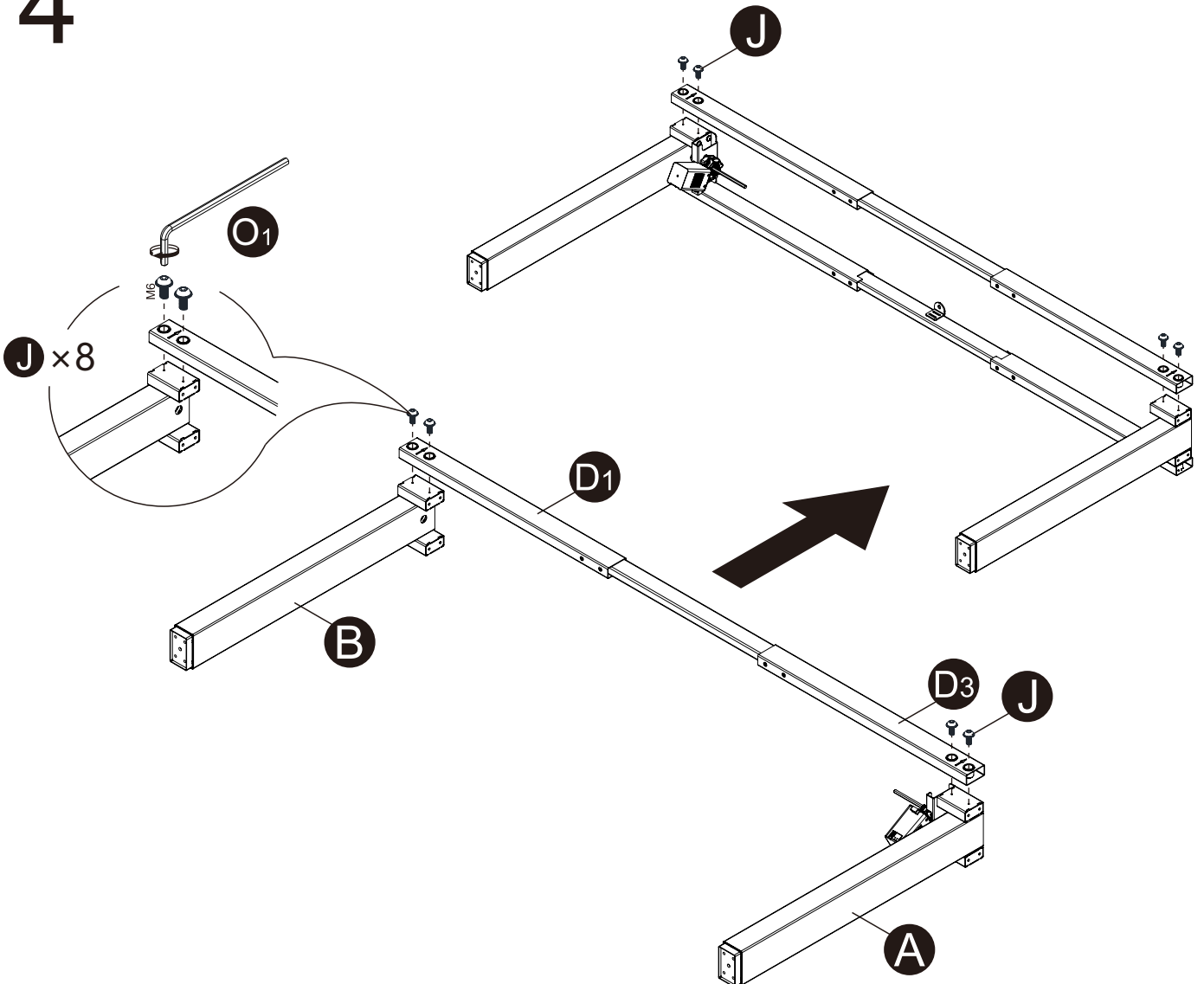

# 5

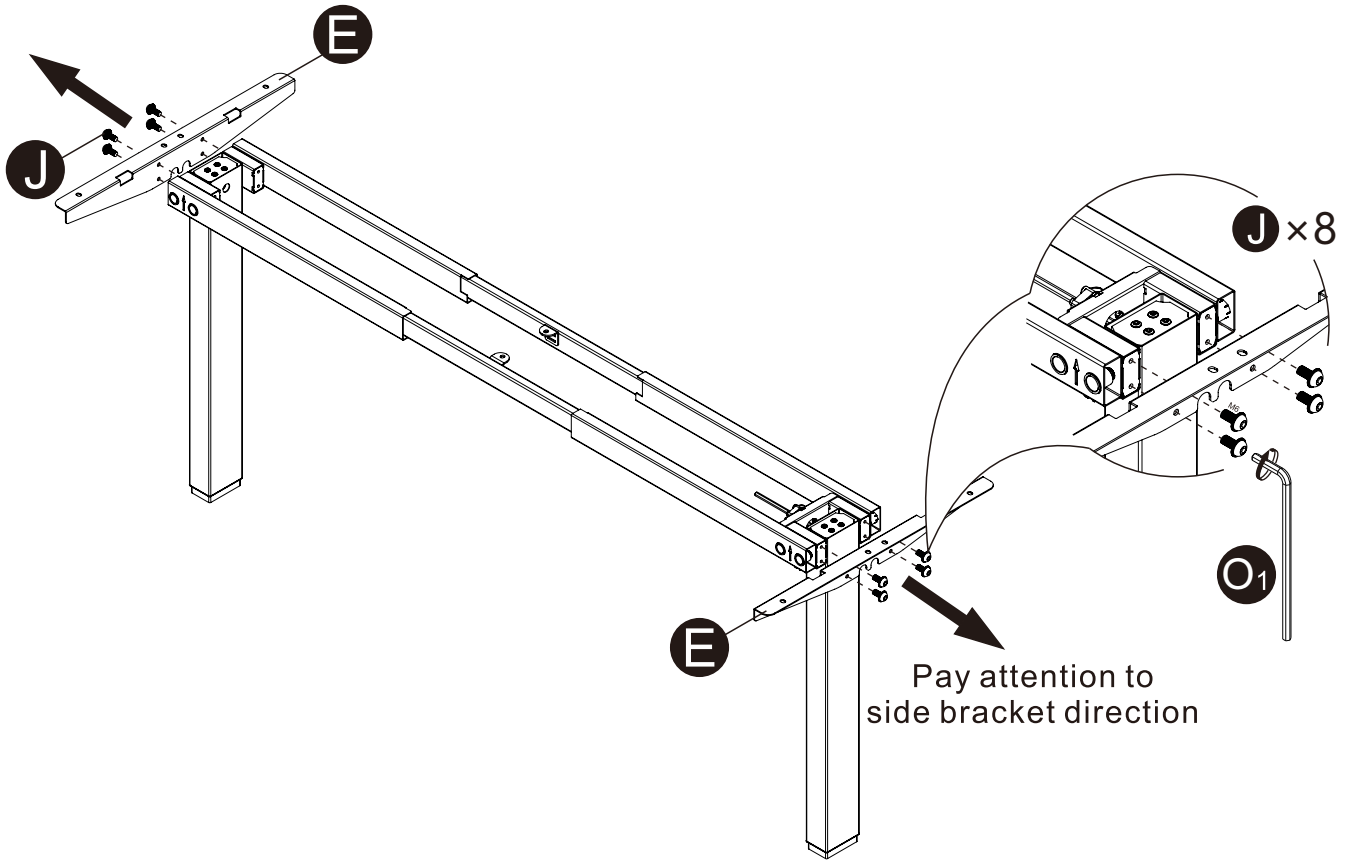

# 6

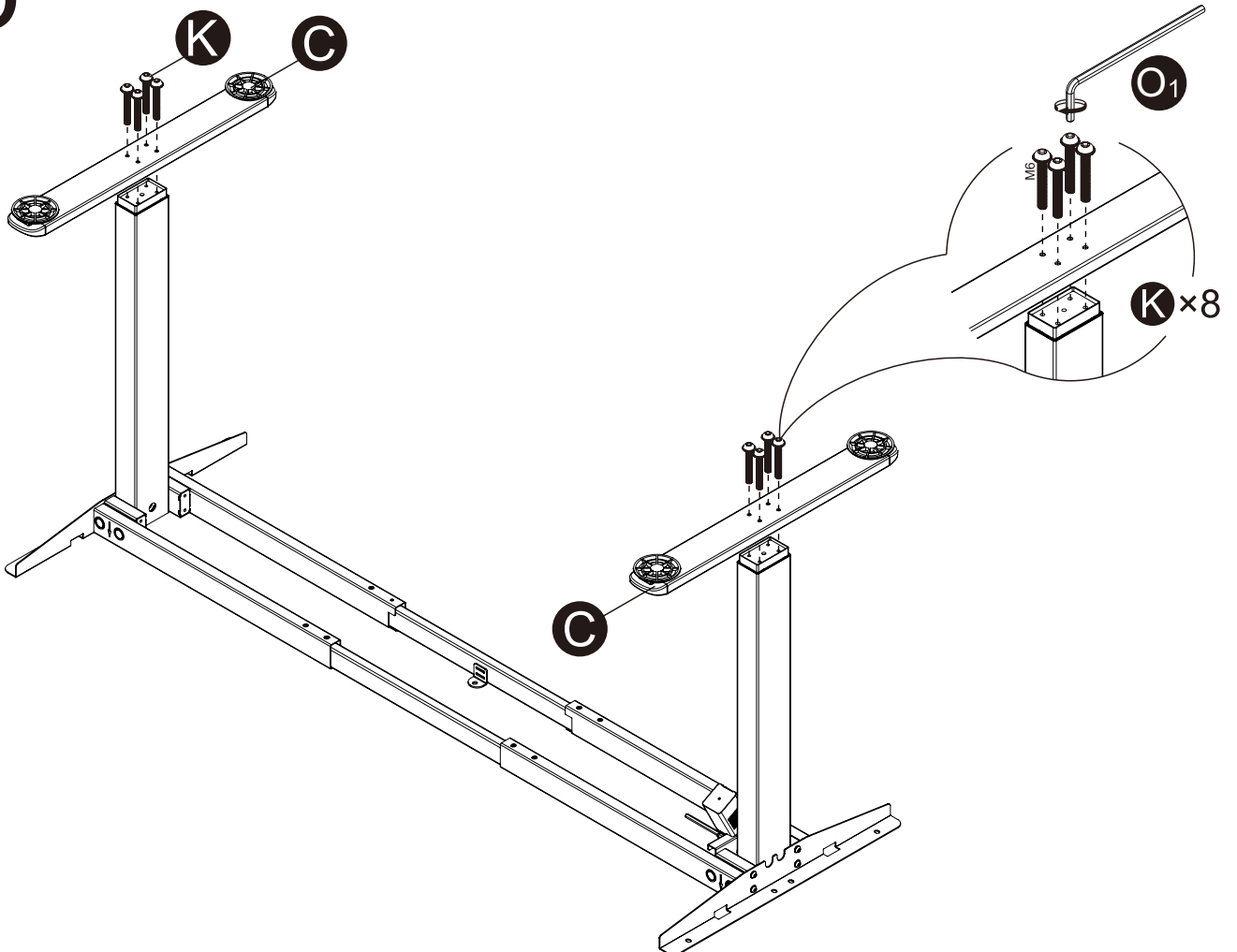

# 7

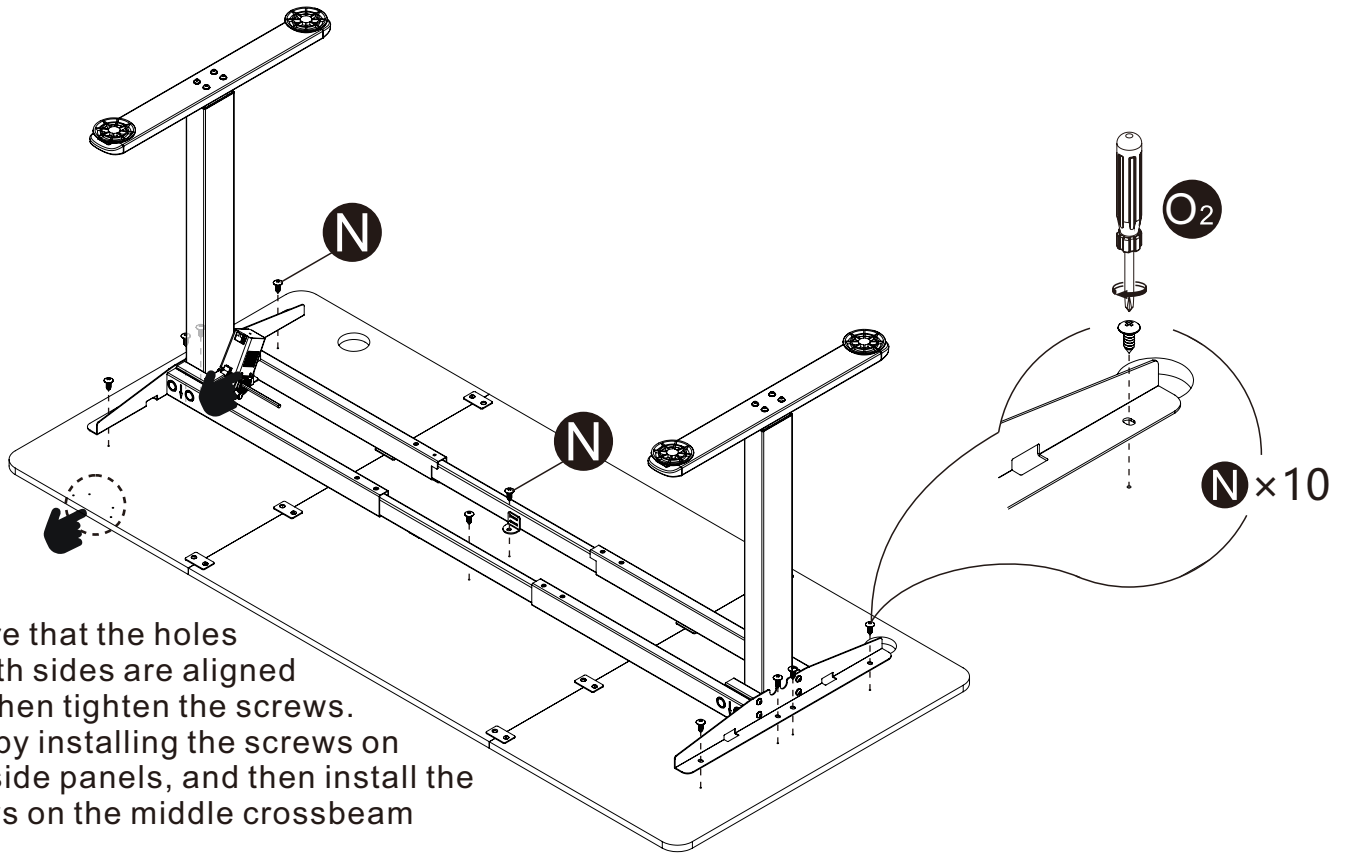

Ensure that the holes on both sides are aligned first, then tighten the screws. Start by installing the screws on both side panels, and then install the screws on the middle crossbeam

# 8

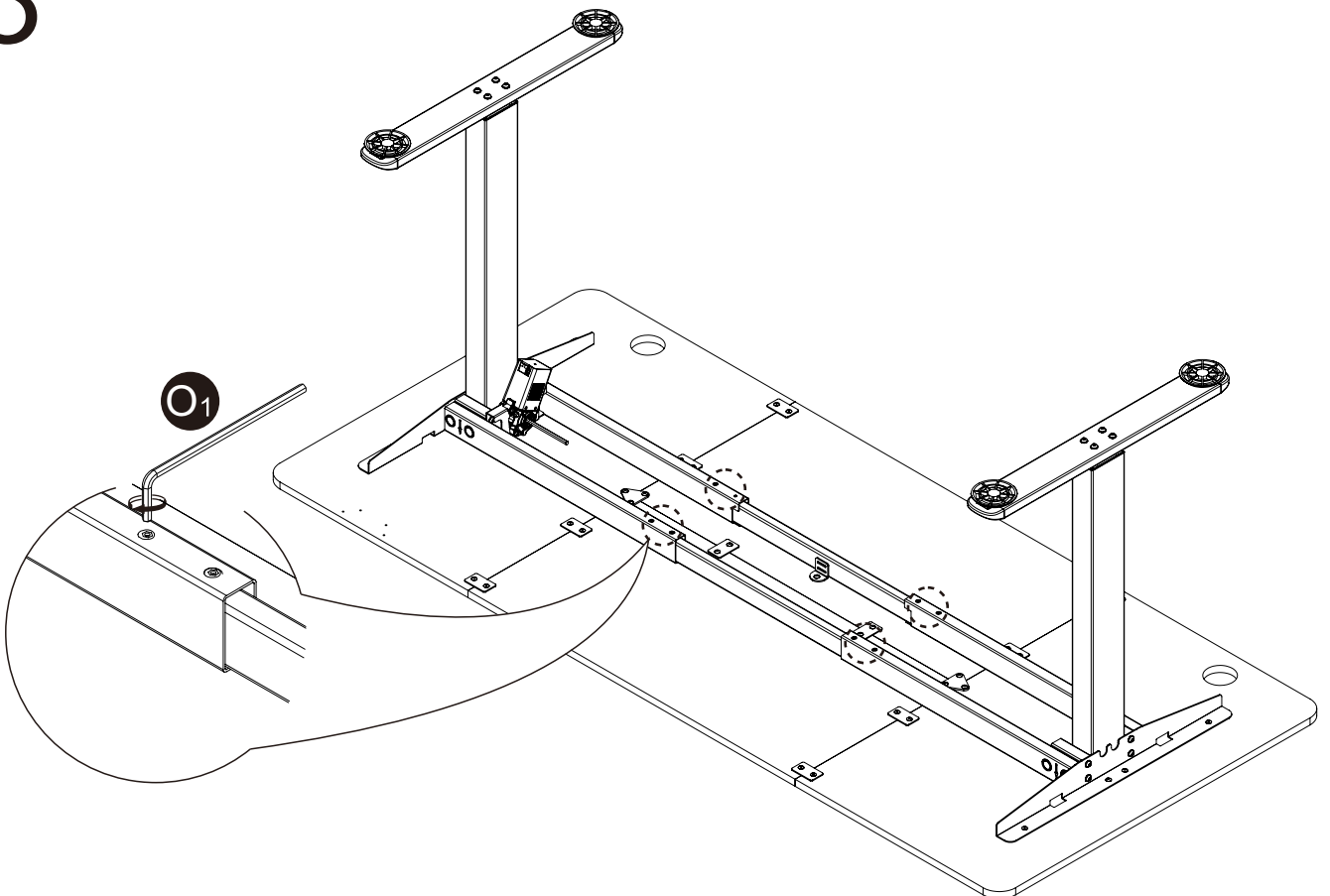

9

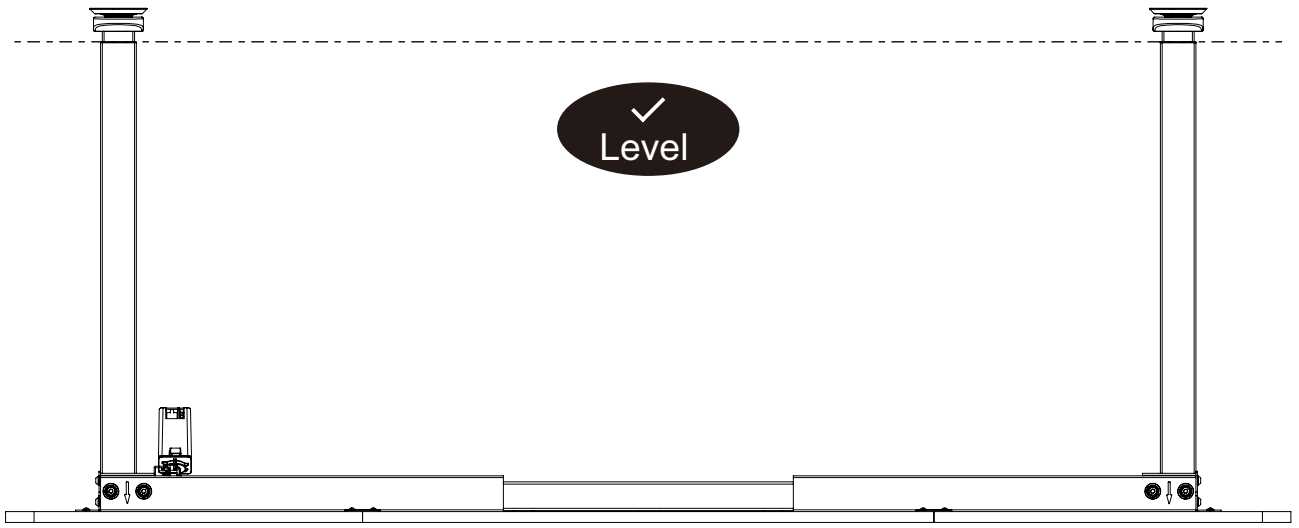

10

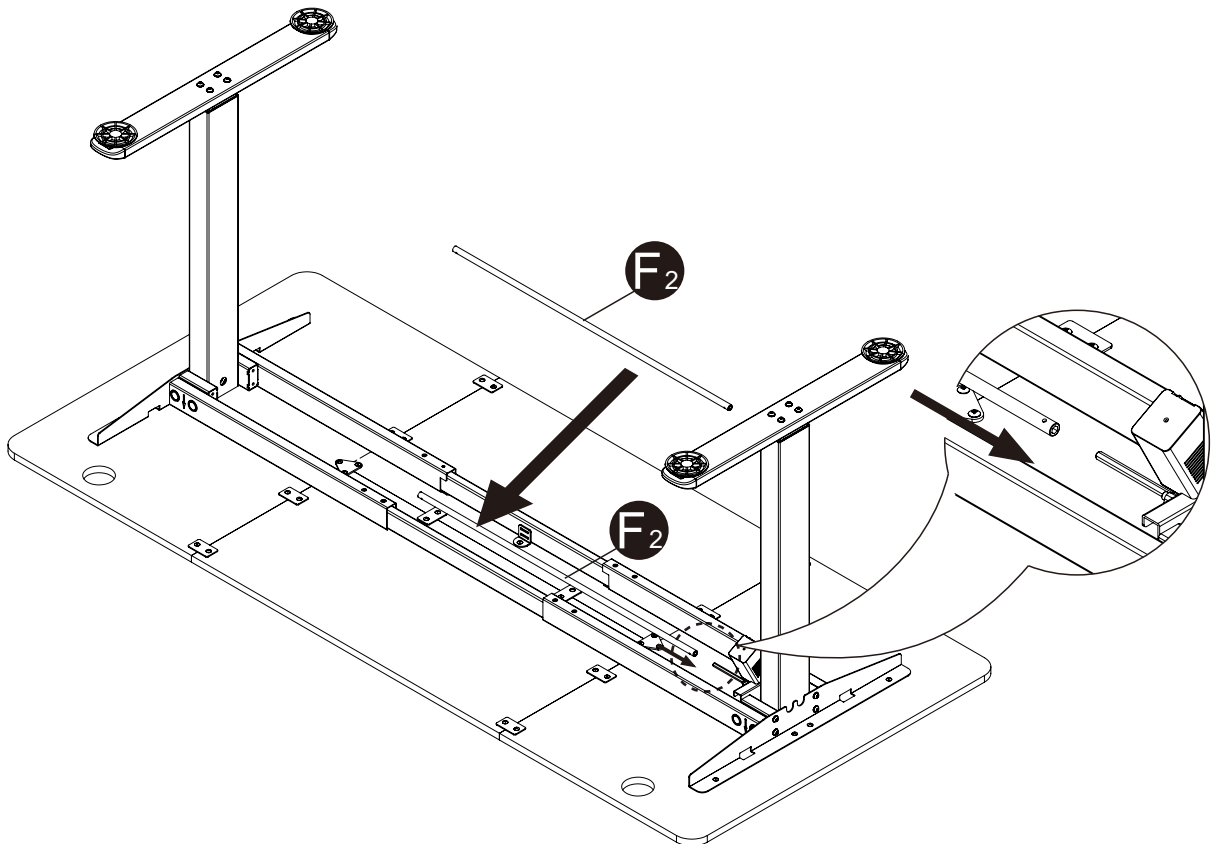

# 11

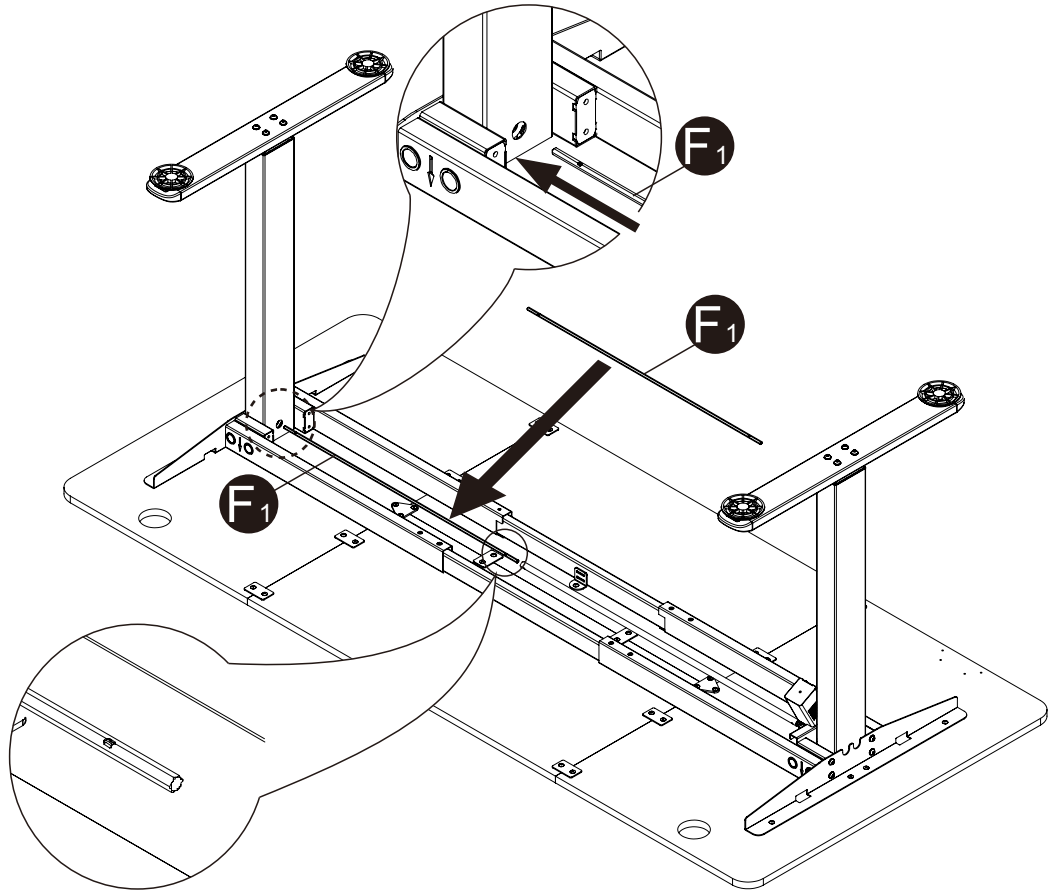

# 12

If the hexagonal rod doesn't fit into the motor leg, use a wrench to gently rotate the hexagonal bar on the aisle leg to align the holes.

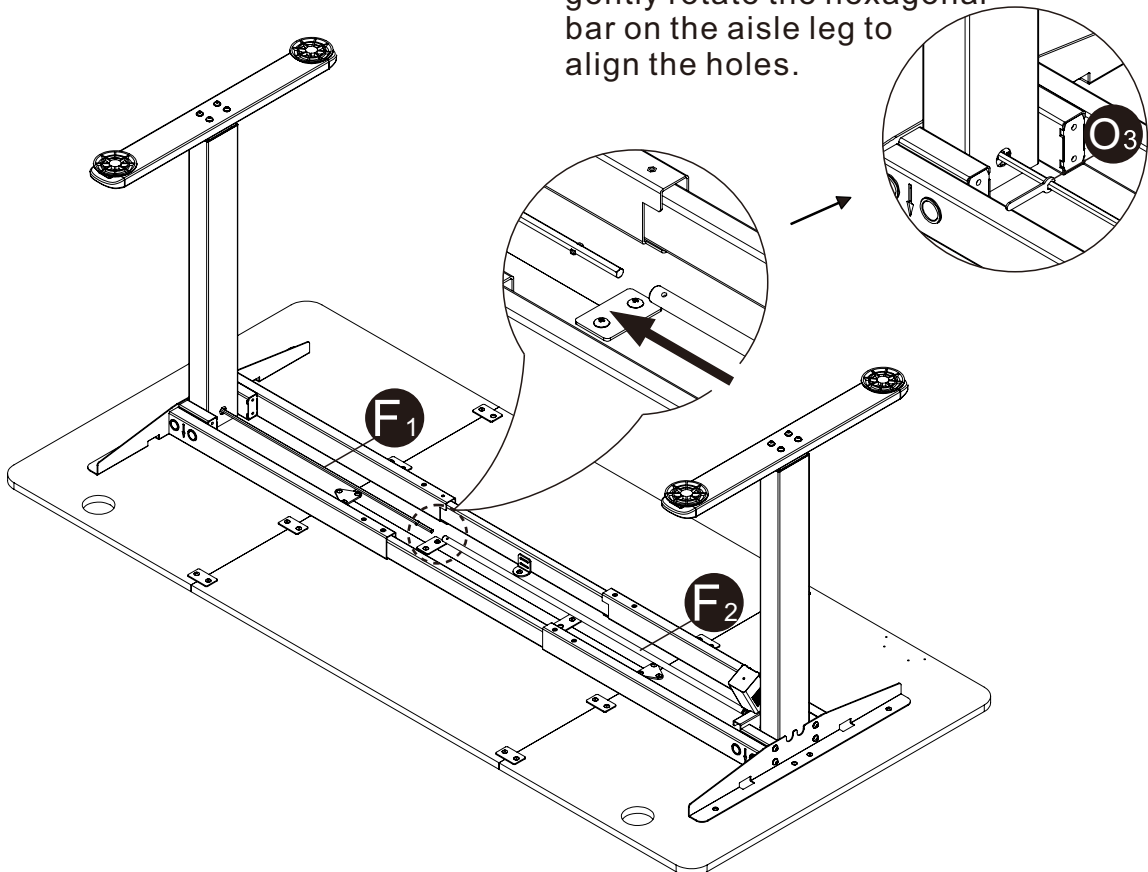



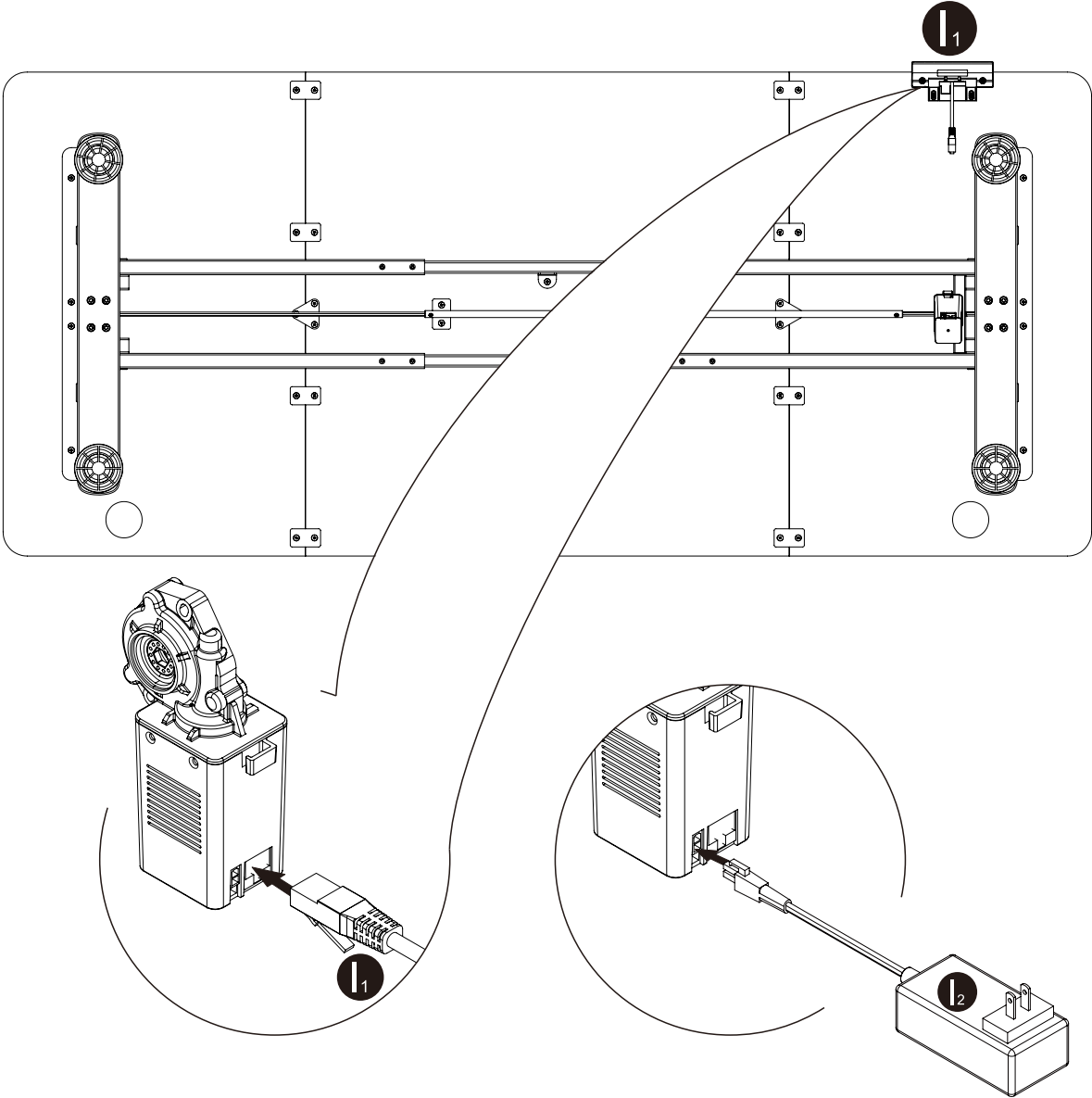

# 16

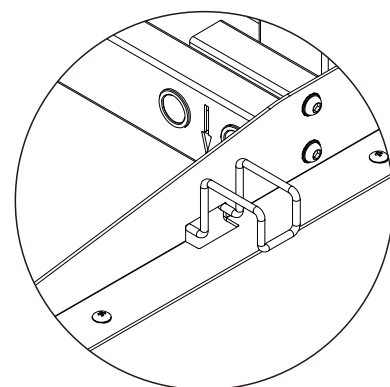
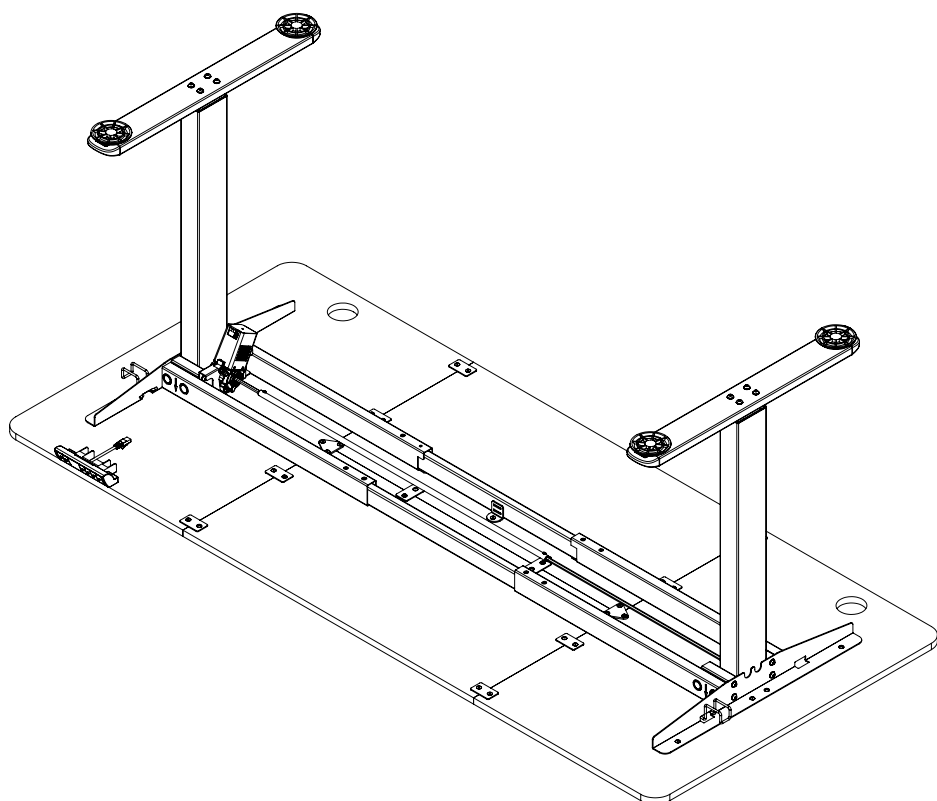
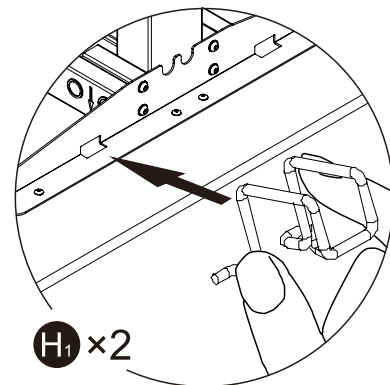
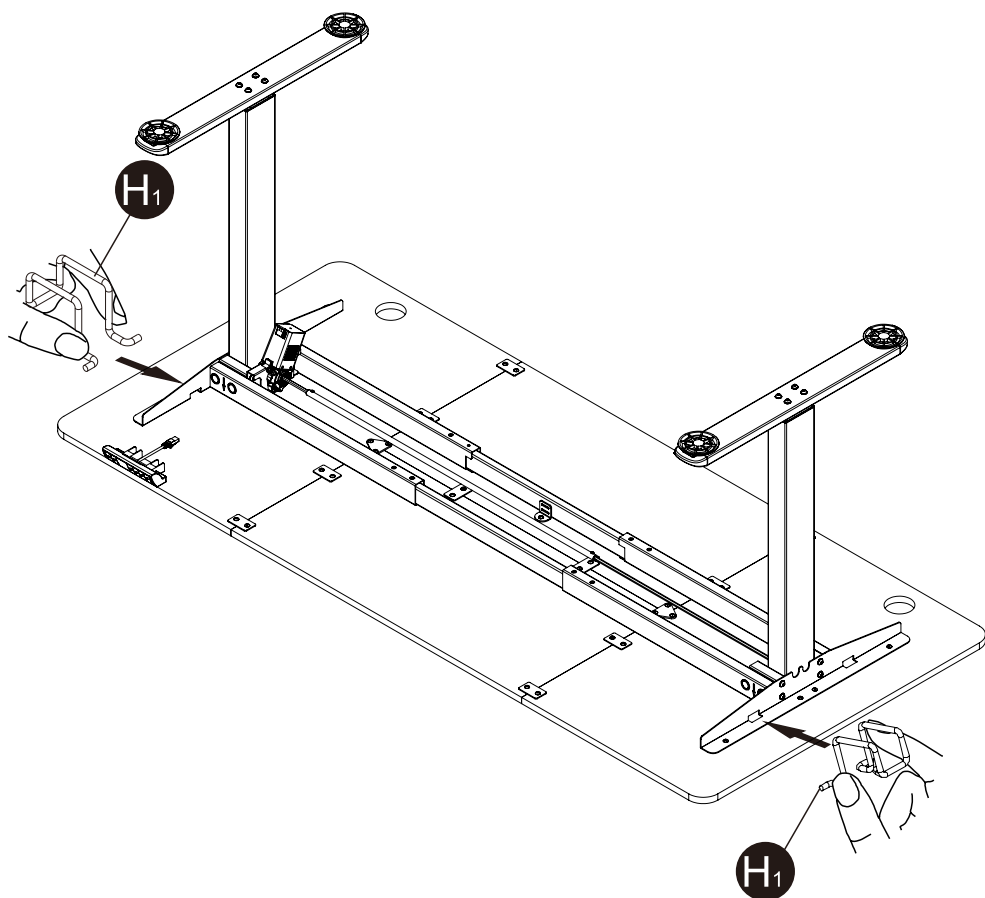

# 17

(Selective assembly)

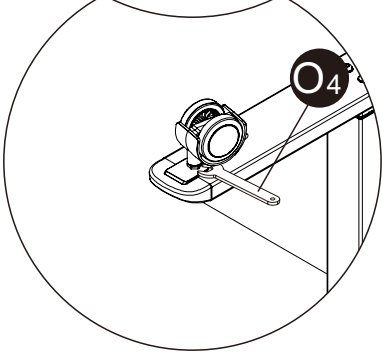
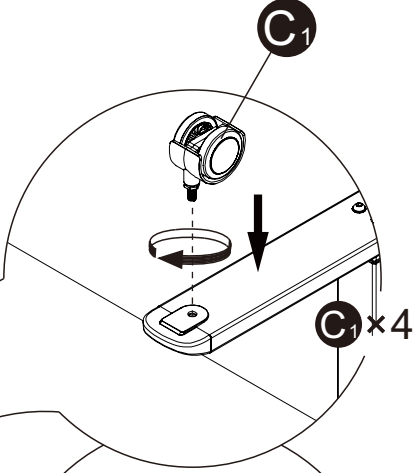
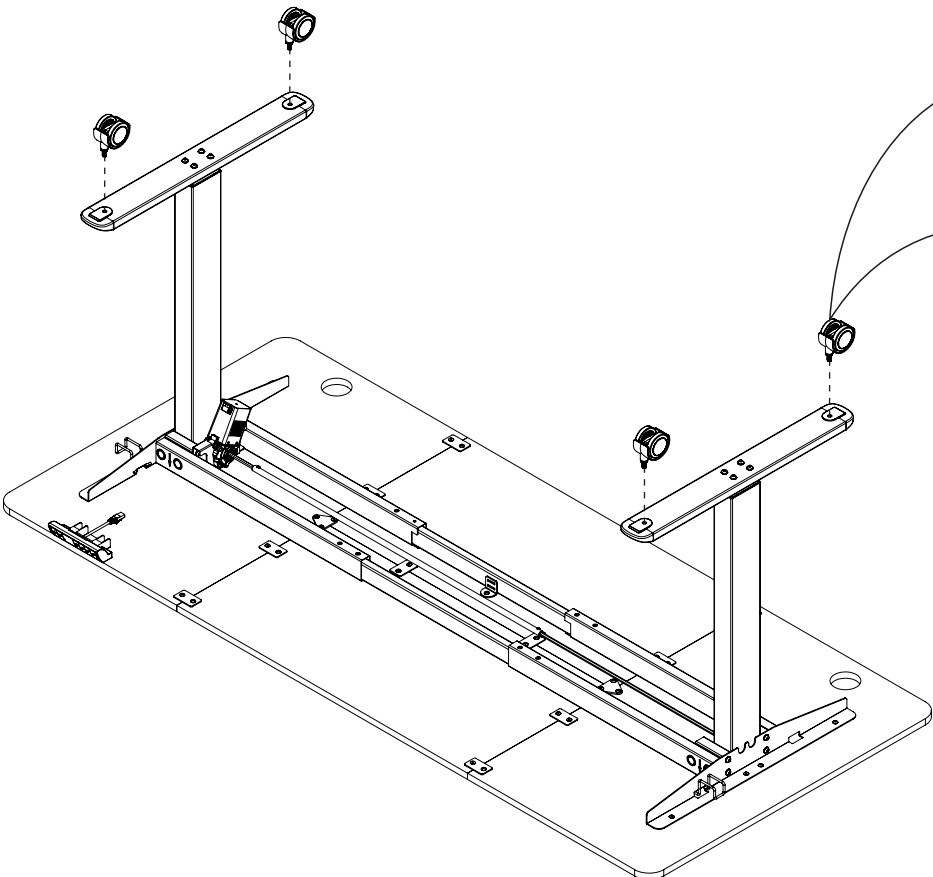
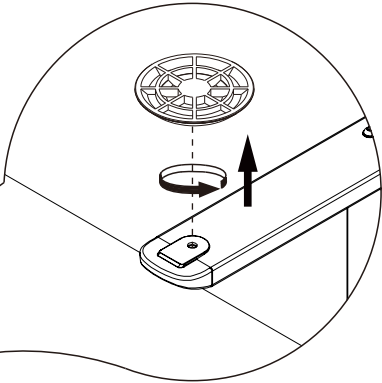
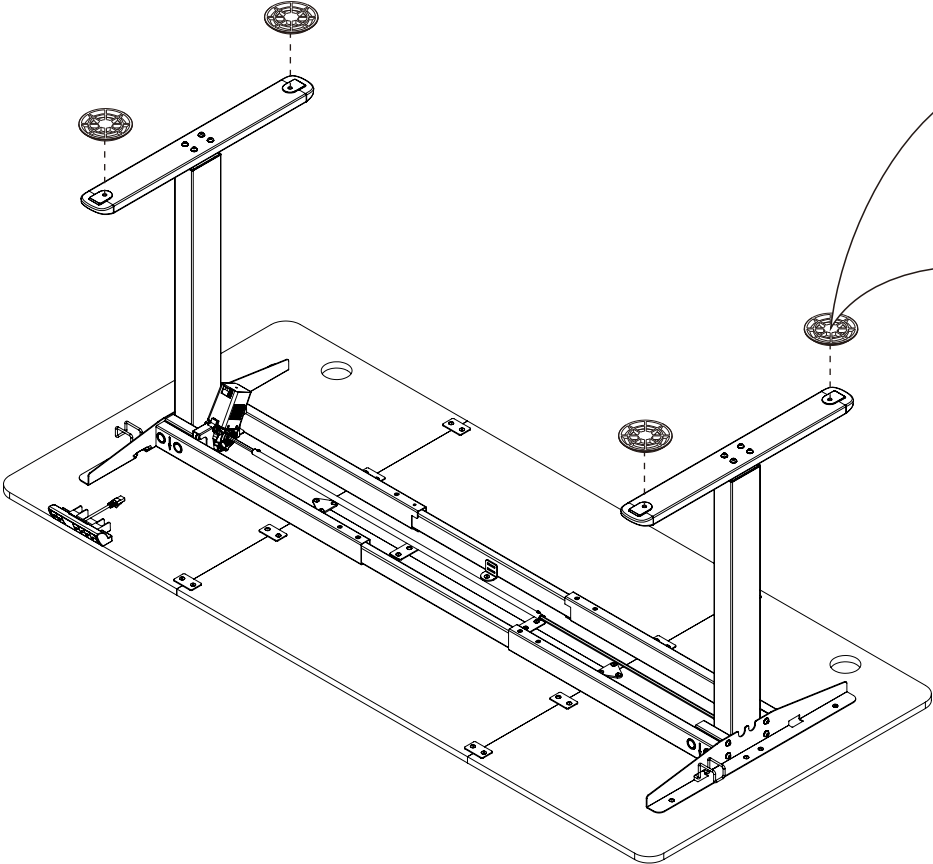

# 18

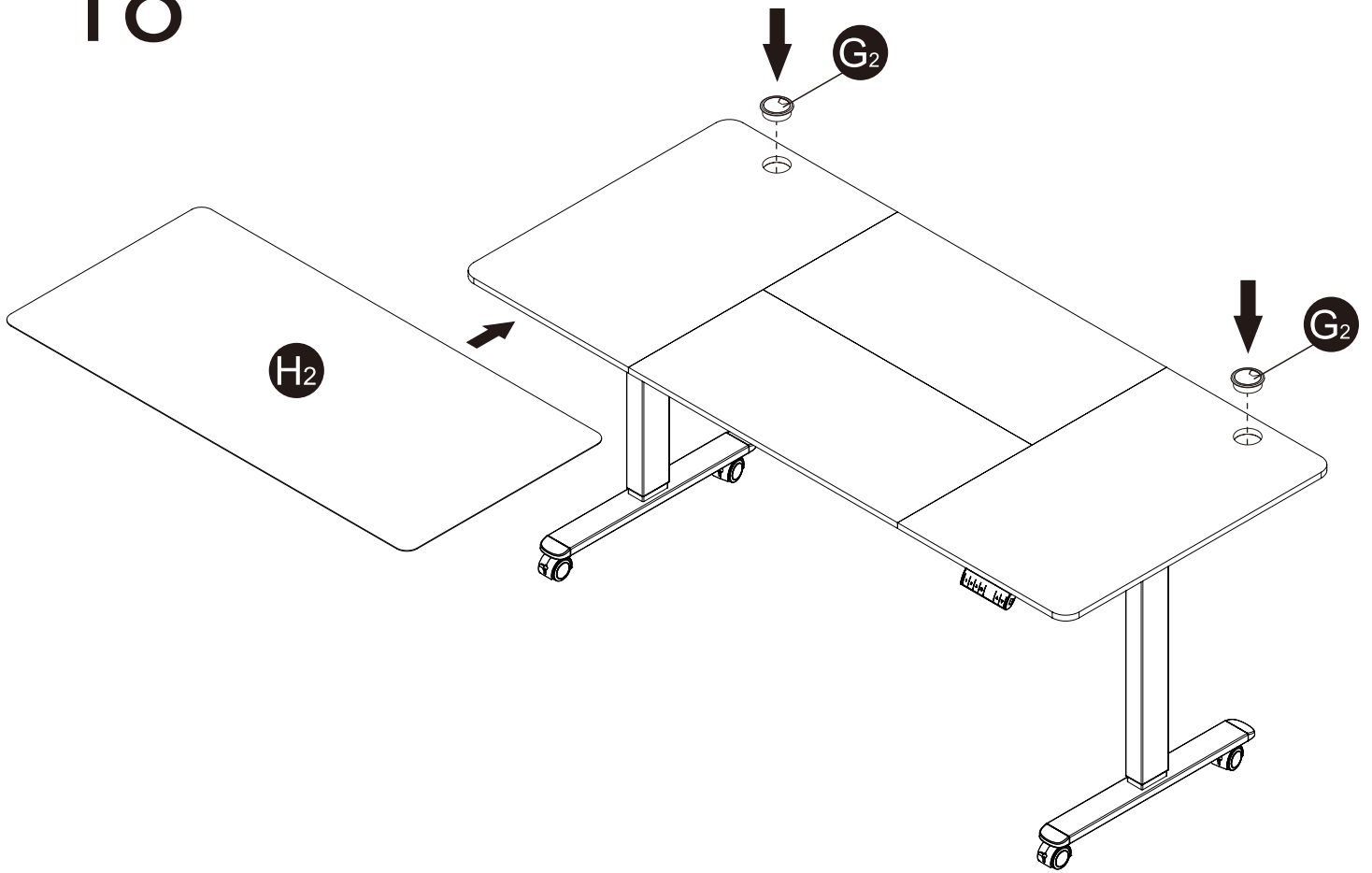

# 19

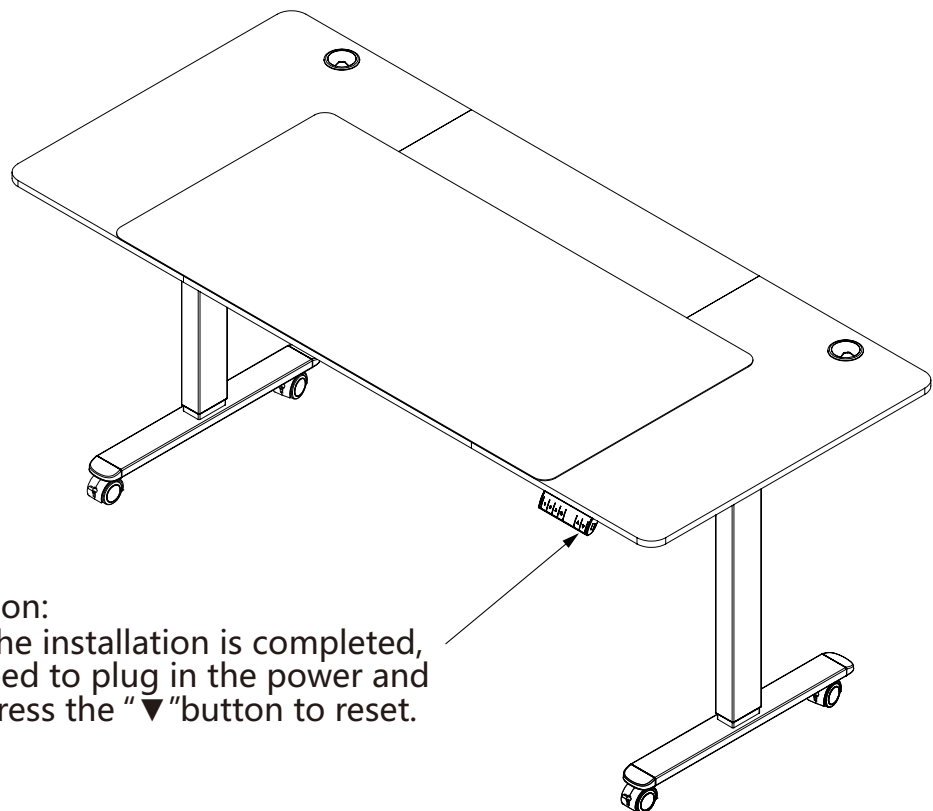

Attention:  
After the installation is completed,  
you need to plug in the power and  
long press the "▼" button to reset.

## Instructions



1. Initialization operation	When the system is malfunctioning or when the hand controller displays "RST", it is necessary to initialize the lifting table. The initialization process involves pressing and holding the "v" button until the motor stop, then releasing the button, and finally pressing "^" for 5 seconds to automatically enter initialization mode. During this time, the "v" key must not be released. If the "v" key is released, the system will exit initialization mode. Once the initialization is complete, a buzzer will sound to indicate a successful initialization.
2. Up and down key operation	<ol style="list-style-type: none"> <li>1. Pressing the "^" key will cause the desktop to move upward until it reaches its highest point.</li> <li>2. Pressing the "v" key will cause the desktop to move downward until it reaches its lowest point.</li> <li>3. When the "^" or "v" key is briefly pressed, the desktop will move a short distance to achieve precise positioning (also known "inching").</li> </ol>
3. Position storage and memory operation	The hand controller in the above picture can store 3 memory points. The storage method is as follows. When running to a specific point, press and hold the position "1-3" button for 5 seconds, and you will hear Buzzer sound, store the position at this time to the corresponding label.
4. Lock and unlock	<ol style="list-style-type: none"> <li>1. Locking: To lock the system, press and hold the "1" and "2" buttons simultaneously for 5 seconds. The digital tube will display "Loc", indicating that the system is locked and cannot be moved up or down.</li> <li>2. Unlocking: To unlock the system, press and hold the "1" and "2" buttons simultaneously for 5 seconds. The digital tube will display the normal numerical value, indicating that the system is unlocked.</li> </ol>
5. Timing operation	Press the "🕒" button on the hand controller to display the current time as x.xh. Use the "^" or "v" button to adjust the timing in increments of 0.5 hours. The setting range is 0.5-2 hours, and the setting is automatically saved after 2 seconds. After exiting, a decimal point will flash on the hand controller, indicating that the timer is running. When the timer reaches the designated time, the buzzer will sound 5 times, and the hand controller will automatically wake up.

## Error code

Error code	Description	Solution suggestion
E01	Mains voltage exceeds 45V.	Check the mains power.
E02	The height deviation between the screw rods is more than 1cm.	Reinitialize the system.
E04	Hand controller is not connected or there is a communication error.	Check the hand control wire.
E05	Display shows "Stop" when blocked.	Release the button and restart the system.
E06	Main power failed to start due to voltage lower than 20V.	Replace the main power supply or check the main power supply cable.
E07	Main power failed to start due to voltage lower than 20V.	Power on the system again.
E08	Desktop tilts while in motion.	Reinitialize the system.
HOT	Power supply temperature is too high or has been running continuously for more than 4 minutes within an 18-minute interval.	Wait for the power supply to cool down or let the system rest for 18 minutes before restarting.
E11	Motor 1 is not connected.	Check the cable.
E12	Error in motor 1 current sampling channel.	Replace the control board.
E13	Motor 1 phase is lost or a phase line is disconnected.	Check if the motor's phase wire connection is abnormal.
E14	Motor 1 Hall error, or Hall line is disconnected.	Check the Hall signal or replace the connecting wire.
E15	Internal short circuit detected in Motor 1.	Replace the motor if necessary.
E16	Motor 1 is stalled.	Reinitialize the system.
E17	Motor 1 is running in the wrong direction.	Replace the motor wire or Hall wire if there is a problem.
E18	Motor 1 is overloaded.	Reduce the load on the system.
E42	Memory error.	Replace the controller if needed.
E43	Stop sensor error.	Install a new controller if the current one is faulty.