

# **Thermostatic Shower Faucet Installation Manual**

**W-83(ES)**

# Warranty Duration

All components of this faucet system are covered under a lifetime limited warranty, ensuring they are free from defects in material and workmanship for the original purchaser.

# Repair and Replacement

If the product shows defects in material or workmanship under normal use and within the warranty period, we will, at our discretion, either repair the product or provide a replacement at no cost to the original purchaser. Please note that proof of purchase (e.g., an invoice) is required when requesting service. The warranty does not cover damages caused by improper installation, misuse, or modifications.

# Exclusions

We shall not be responsible for the following cases:

- Damage to the product caused by improper installation, misuse, unauthorized repair or replacement, or abuse (including damage during shipment).
- Damage to the product caused by improper dismantling after installation.
- Damage resulting from abnormal water pressure or impurities in water pipes, which is not covered under this warranty.
- Rust on the product due to insufficient care and maintenance, which is not covered under this warranty.
- Damage caused by natural disasters such as fire, flood, earthquake, lightning storms, etc., which is not covered under this warranty.

I hope this helps! If you have any further questions or concerns, please let me know.

# Having Trouble? Contact us.

✉ Email: [info@faucetsupport.com](mailto:info@faucetsupport.com)

☎ Toll Free: 1-888-969-6880

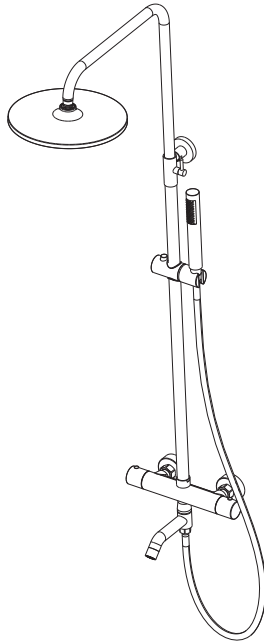

**M6974**  
**SFS-1138**  
**Model:A**

## **CONTENT**

**1. Installation Instructions for Thermostatic Shower Faucet ----- (1-6)**

## **CONTENIDO**

**1. Instrucciones de instalación para el grifo de ducha termostático---(7-12)**

## ◆ Installation and Maintenance Matters

1. Check the accessories list to verify that all parts are complete in this package.
2. Do not disassemble the main body by yourself.
3. Connect inlet pipes to supply valves.
4. Make sure inlet pipes and supply valves have no impurities and are cleaned, with no impurities in the pipeline.
5. After installation, check all joints for leakages.
6. Do not leave the rain shower system exposed to a severely corrosive environment.

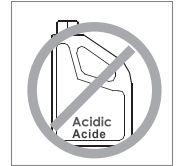
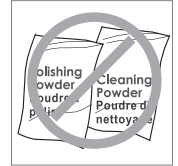
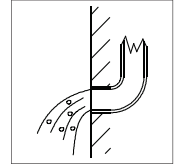
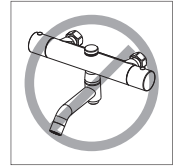

### Do's

1. In order to keep the mixer surface bright, please clean the mixer regularly.
2. Rinse the faucet with clean water and wipe it with a soft cotton cloth.
3. Use one of the following cleaners to remove dirt from the surface: a. Mild liquid cleaner. b. Colorless glass cleaner and powder cleaner that do not cause abrasion and can be dissolved completely. c. Polish liquid that does not cause abrasion.

### Don'ts

- a. Avoid using cleaning powder, harsh cleaning chemicals, brushes and coarse cloth to prevent scratching and friction.
- b. Do not use acid cleaners to clean the faucet as they may cause surface corrosion of the faucet. If the faucet is exposed to harmful acid substances, please rinse it immediately with water.

### Tools Needed:

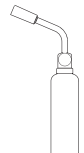
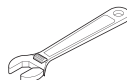
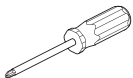

◆ **Three-Function Shower Set**  
**Model:A**  
**Accessories List**

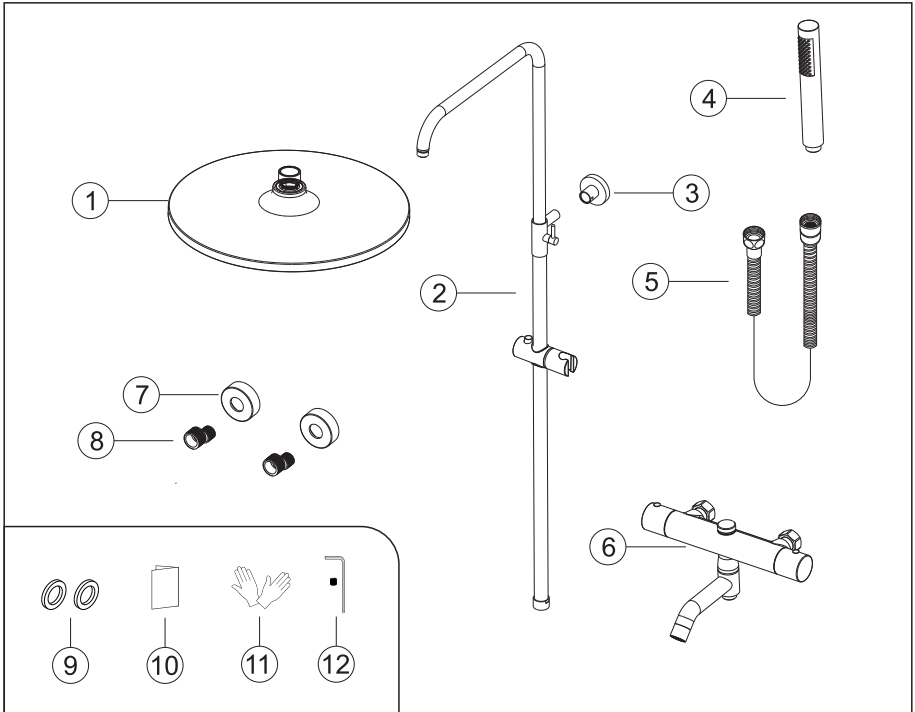

No.	Part name	Qty	No.	Part name	Qty
1	Shower head	1	7	Flange	2
2	Adjustable slide Bar	1	8	Angled connector	2
3	Mounting bracket	1	9	Rubber gasket	3
4	Shower hand	1	10	Instruction manual	1
5	Shower hose	1	11	Gloves	1pair
6	Main body	1	12	Mounting bracket screws	1set

## ◆ Essential Dimensions & Water Pipe Line

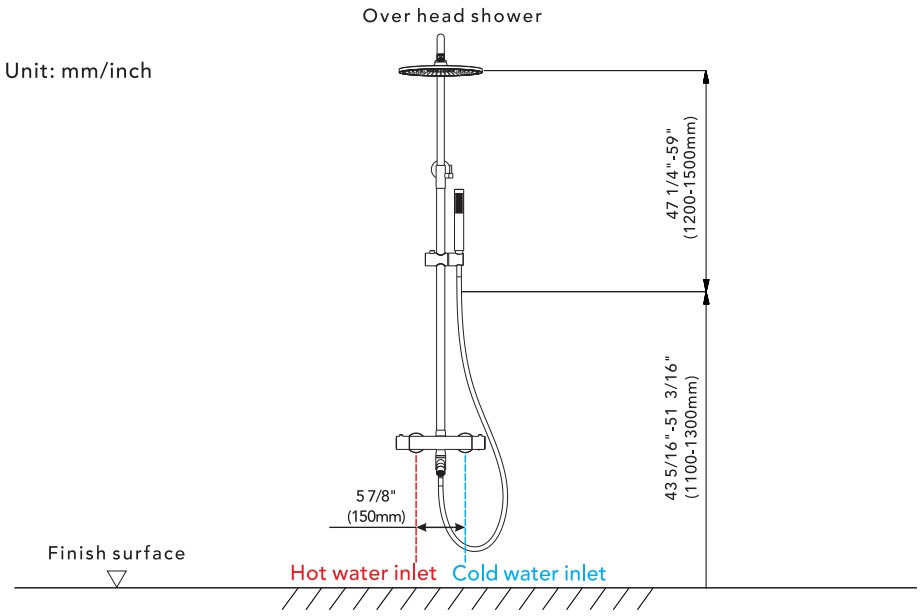

## ◆ The Installation Depth of Angled Connector

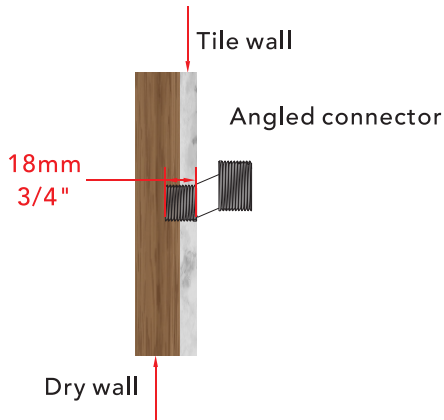

The thickness of the tile must be calculated for installation.

Connector size of male thread: USA: 1/2"-14NPT, Canada: 1/2"-14NPT, Europe: G1/2".

## ◆ Main Body Installation

### Step 1

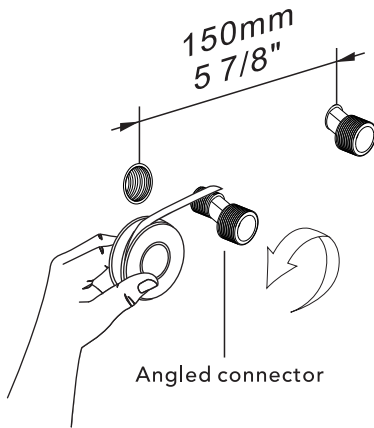

After wrapping the thread seal tape, connect the angled connector to the water outlet. The distance between the hot and cold water outlets should be 150 mm (5 7/8"), and the installation height from the floor should be adjusted according to the bathtub height.

### Step 2

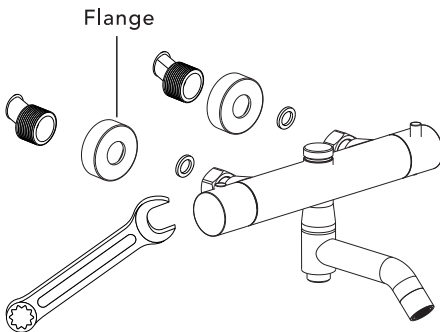

Screw the flange onto the angled connector. Then, install the main body onto the angled connector and tighten it with a wrench.

**(Note: It is recommended to wrap tape around the spanner to prevent scratching the product surface.)**

## ◆ Main Body Installation

### Step 3

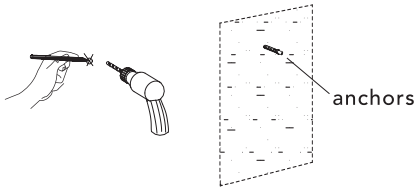

After marking the screw hole positions for the mounting bracket on the concrete wall (For wooden walls, simply screw in the screws directly.), drill the holes using a suitable tool and insert the expansion anchors.

### Step 4

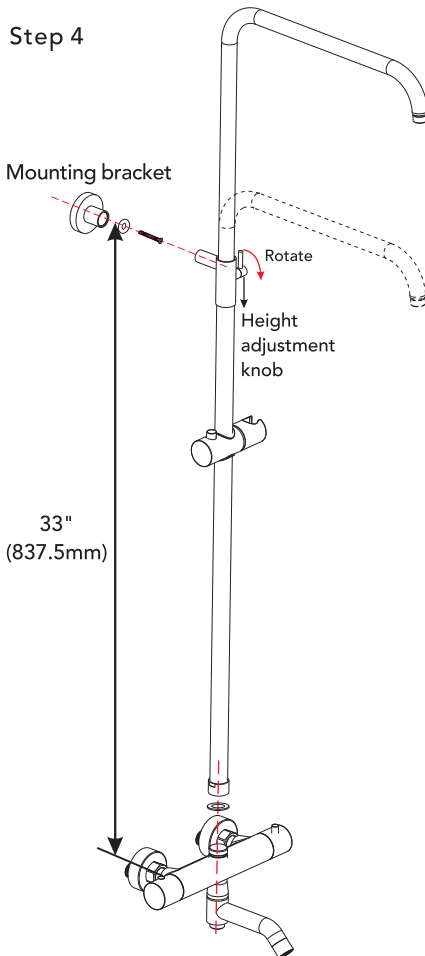

1. According to the reference diagram, insert the screws through the holes of the mounting bracket and drive them into the wall using a screwdriver.
2. Attach the shower slide bar onto the mounting bracket and tighten the hex screw at the bottom to secure it.
3. Rotate the Height Adjustment Knob counterclockwise to loosen it, then adjust the height of the shower slide bar as needed.
4. Connect the lower end of the shower slide bar to the main body, and tighten the nut using a wrench.

**Note:**The center height of the main body mounting must be aligned with the center height of the shower bar at 33" (837.5 mm); otherwise, the shower bar may not be installable.

## ◆ Hand Shower Installation

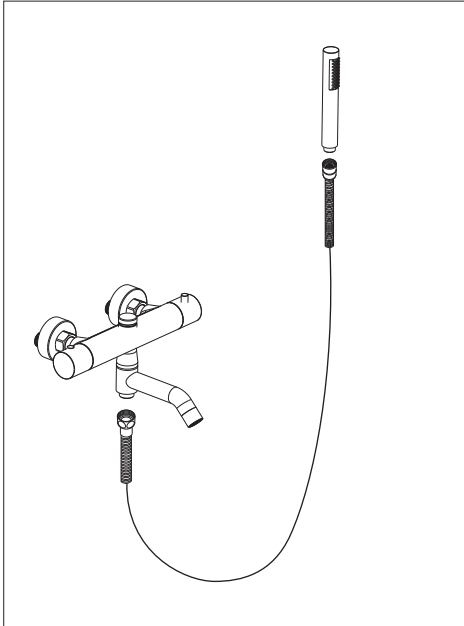

As shown in the figure, connect the shower hose to the lower outlet of the main body and tighten it securely.

Turn on the water to check for any leaks at the connection point.

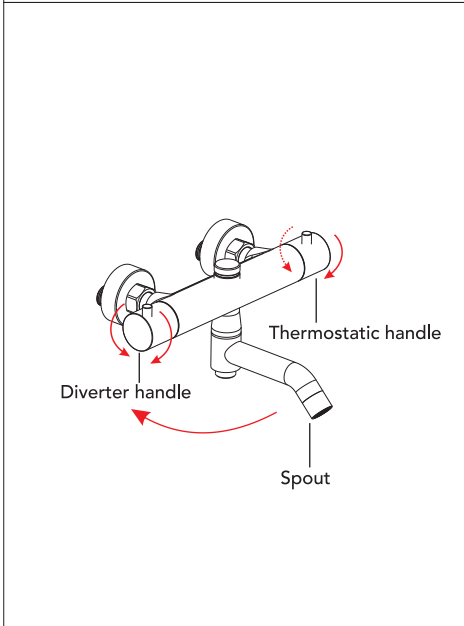

1. Rotate the diverter handle (the left handle when facing the outlet) clockwise or counterclockwise to switch between different water outlets.

2. Rotate the thermostatic handle (the right handle when facing the outlet) clockwise or counterclockwise to turn on cold water or switch to hot water.

3. Swing the spout to the left to stop water flow from the spout and activate the lower outlet (hand shower for this model). Swing it back to the right to resume water flow from the spout and shut off the hand shower.

## ◆ Instalación y cuestiones de mantenimiento

1. Verifique la lista de accesorios para comprobar que todas las partes están completas en este paquete.
2. No desmonte el cuerpo principal por sí mismo.
3. Conecte las tuberías de entrada a las válvulas de suministro.
4. Asegúrese de que las tuberías de entrada y las válvulas de suministro no tengan impurezas y estén limpias, sin impurezas en la tubería.
5. Después de la instalación, verifique todas las uniones para detectar fugas.
6. No deje el sistema de ducha tipo lluvia expuesto a un ambiente severamente corrosivo.

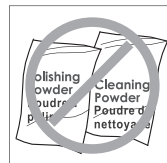
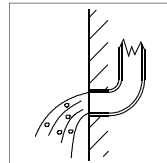
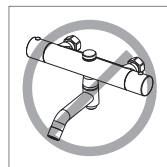

### Hacer

1. En para mantener la superficie de la batidora brillante, limpie el mezclador regularmente.
2. Inse el grifo con agua limpia y límpielo con un suave ropa de algodón.
3. Utilice uno de los siguientes limpiadores para eliminar la suciedad de la superficie: a. Limpiador líquido suave. b. Limpiador de vidrio incoloro y limpiador en polvo que no causen abrasión y que se puedan disolver completamente. c. Líquido pulidor que no cause abrasión.

### No es decir

- A. Valte con polvo de limpieza, productos químicos de limpieza duros, cepillos y tela gruesa para evitar rasgar y fricción.
- B. No use limpiadores de ácidos para limpiar el grifo, ya que pueden causar corrosión superficial del grifo. Si el grifo está expuesto a sustancias ácidas dañinas, enjuague inmediatamente con agua.

## HERRAMIENTAS NECESARIAS:

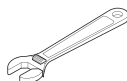
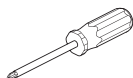

♦ **Juego de ducha de tres funciones**

**Modelo:A**

**Lista de Accesorios**

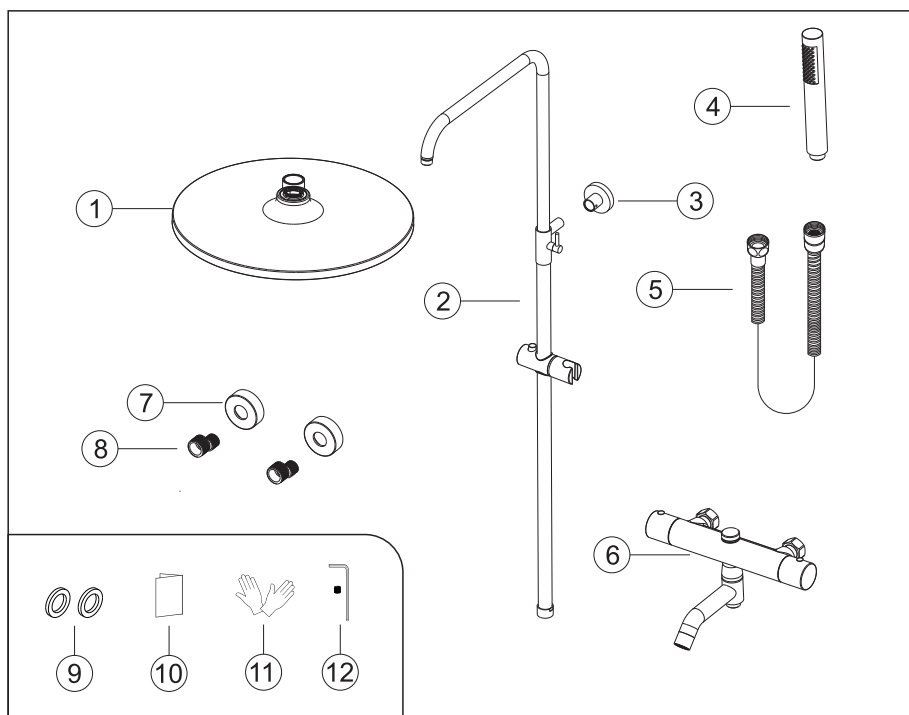

N.º	Nombre de la pieza	Cantidad	N.º	Nombre de la pieza	Cantidad
1	Cabezal de ducha	1	7	Brida	2
2	Barra deslizante ajustable	1	8	Conector de ángulo curvo	2
3	Soporte de montaje	1	9	Junta de goma	3
4	Ducha de mano	1	10	Manual de instrucciones	1
5	Manguera de ducha	1	11	Guantes	1 par
6	Cuerpo principal	1	12	Tornillos del soporte de montaje	1 juego

## ◆ Dimensiones esenciales & línea de tubería de agua

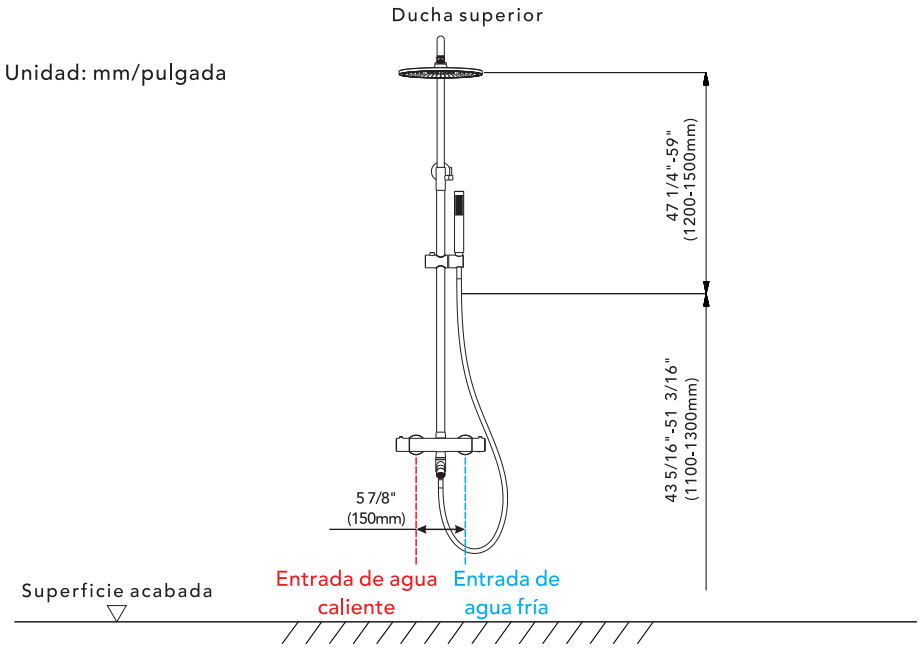

## ◆ La profundidad de instalación del brazo de ducha

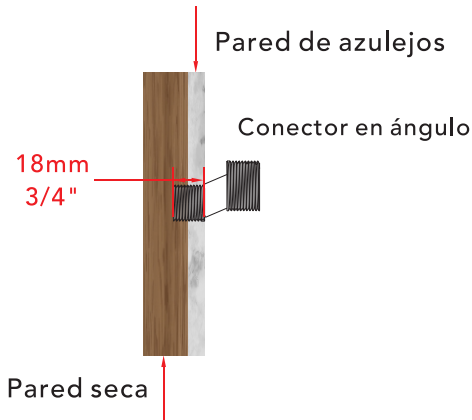

El grosor del azulejo debe ser calculado para la instalación.

Tamaño del conector de rosca macho: EE. UU.: 1/2"-14NPT, Canadá: 1/2"-14NPT, Europa: G1/2".

## ◆ Instalación del cuerpo principal

### Paso 1

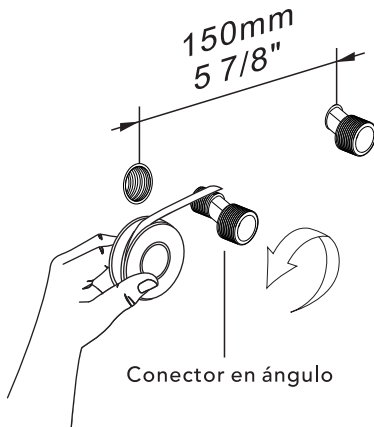

Después de envolver la cinta selladora para roscas, conecte el conector en ángulo a la salida de agua. La distancia entre las salidas de agua caliente y fría debe ser de 150 mm (5 7/8"), y la altura de instalación desde el suelo debe ajustarse según la altura de la bañera.

### Paso 2

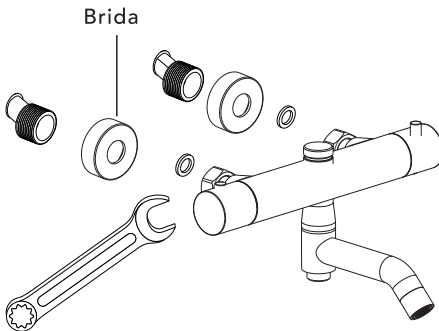

Atornille la brida al conector en ángulo. Luego, instale el cuerpo principal en el conector en ángulo y apriételo con una llave.

**(Nota: Se recomienda envolver cinta alrededor de la llave para evitar rayar la superficie del producto.)**

## ◆ Instalación del cuerpo principal

### Paso 3

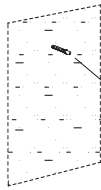
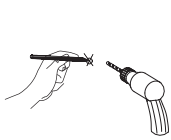

Tacos de anclaje

After marking the screw hole positions for the mounting bracket on the concrete wall (For wooden walls, simply screw in the screws directly.), drill the holes using a suitable tool and insert the expansion anchors.

### Paso 4

Soporte de montaje

33"  
(837.5mm)

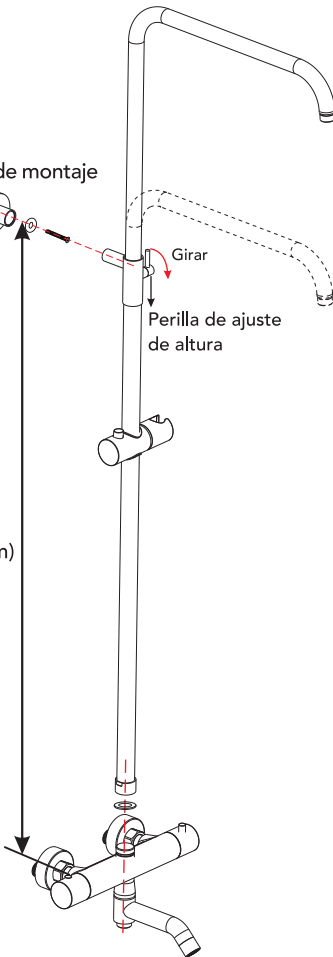

Girar

Perilla de ajuste de altura

1. Según el diagrama de referencia, inserte los tornillos a través de los orificios del soporte de montaje y atornillelos en la pared usando un destornillador.
2. Coloque la barra deslizante de la ducha sobre el soporte de montaje y apriete el tornillo hexagonal en la parte inferior para asegurarla.
3. Gire la perilla de ajuste de altura en sentido antihorario para aflojarla, luego ajuste la altura de la barra deslizante de la ducha según sea necesario.
4. Conecte el extremo inferior de la barra deslizante de la ducha al cuerpo principal y apriete la tuerca con una llave.

**Nota: La altura central del montaje del cuerpo principal debe estar alineada con la altura central de la barra de ducha a 33" (837,5 mm); de lo contrario, es posible que no se pueda instalar la barra de ducha.**

## ◆ Instalación de la ducha de mano

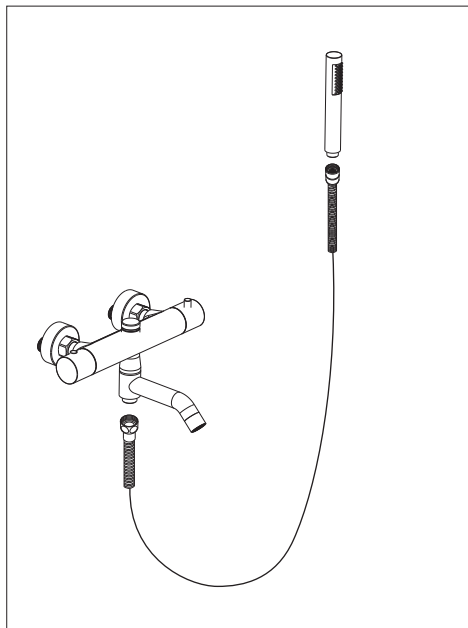

Como se muestra en la figura, conecte la manguera de ducha a la salida inferior del cuerpo principal y apriétela firmemente. Abra el agua para verificar si hay fugas en el punto de conexión.

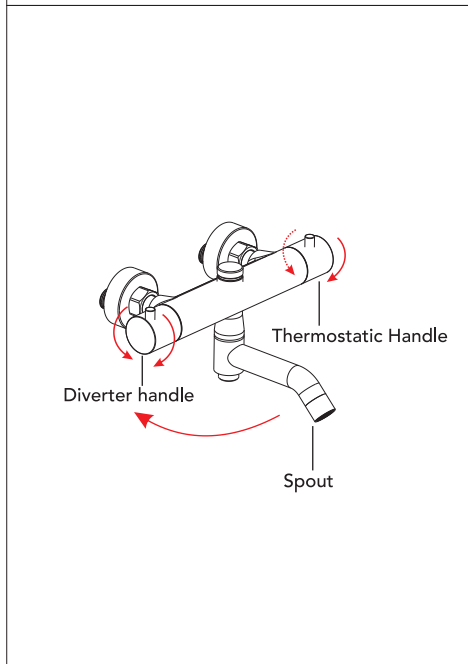

1. Gire la manija del desviador (la manija izquierda al mirar hacia la salida) en sentido horario o antihorario para cambiar entre las diferentes salidas de agua.
2. Gire la manija termostática (la manija derecha al mirar hacia la salida) en sentido horario o antihorario para abrir el agua fría o cambiar al agua caliente.
3. Mueva el surtidor hacia la izquierda para detener el flujo de agua desde el surtidor y activar la salida inferior (ducha de mano en este modelo). Muévelo de nuevo hacia la derecha para reanudar el flujo de agua desde el surtidor y cerrar la ducha de mano.