

Hall Tree

Assembly Instructions - Please keep for future reference

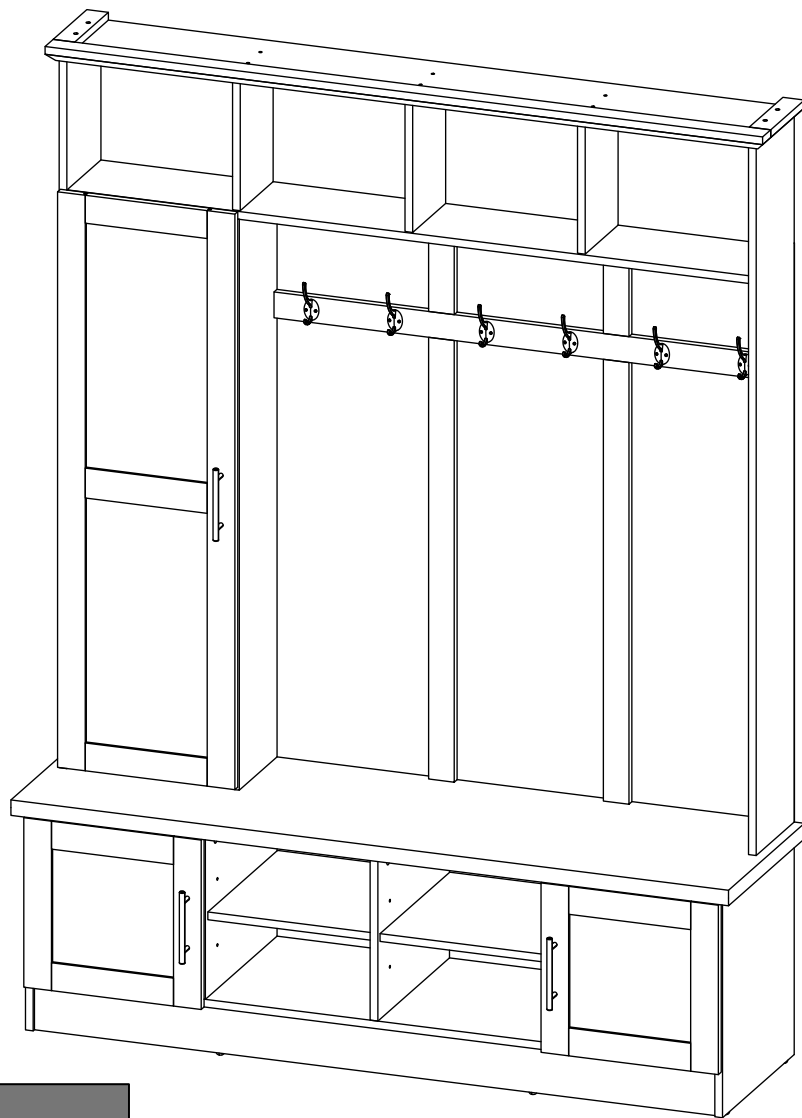

Dimensions

Width-55.12inch

Depth-15.55inch

Height-72.84inch

Important – Please read these instructions fully before starting assembly



Safety and Care Advice

Important – Please read these instructions fully before starting assembly

- Check you have all the components and tools listed on the following pages.
- Remove all fittings from the plastic bags and separate them into their groups.
- Keep children and animals away from the work area, small parts could choke if swallowed.
- Make sure you have enough space to layout the parts before starting.

- During assembly do not stand or put weight on the product, this could cause damage.
- Assemble the item as close to its final position (in the same room) as possible.
- Assemble on a soft level surface to avoid damaging the unit or your floor.
- Parts of the assembly will be easier with 2 people.

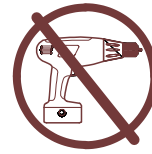

power drill is set on a low torque setting.

- To reduce the likelihood of damaging your product please ensure that your

Care and maintenance

•Only clean using a damp cloth and mild detergent, do not use bleach or abrasive cleaners.

•From time to time check that there are no loose screws on this unit.

•This product should not be discarded with household waste. Take to your local authority waste disposal centre.

Handy Hints

•Assemble all parts and bolts loosely during assembly, only once the product is complete should you fully tighten the bolts

•Regularly check and ensure That all bolts and fittings are tightend properly.

WARNING In order to help prevent overturning – please follow these instructions













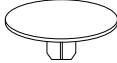



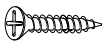
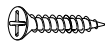

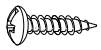
To help prevent product toppling over please follow the below steps:-

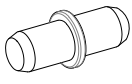
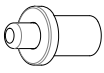
- Use the anti tip stap or wall fixing method provided (if applicable)
- Do not allow children to climb or hang on the furniture
- Do not open more than one drawer at a time
- Do not place heavy items in the top drawers
- Do not place heavy items on top of the furniture, unless the furniture has been designed for this purpose

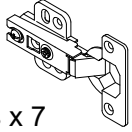
Components - Fittings

Please check you have all the panels listed below

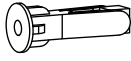
Note: The quantities below are the correct amount to complete the assembly. In some cases more fittings may be supplied than are required.

<p>(A1)</p>  <p>Cam lock x 37 + 2</p>	<p>(A2)</p>  <p>Cam bolt x 37 + 2</p>	<p>(A3)</p>  <p>Cam cap x 37 + 2</p>	<p>(B)</p>  <p>8*30mm Dowel x 54 + 2</p>
<p>(C)</p>  <p>6*50mm Screw x 22 + 2</p>	<p>(D)</p>  <p>Allen key x 1</p>	<p>(E)</p>  <p>3.5*16mm Screw x 50 + 2</p>	<p>(F)</p>  <p>3.5*16mm Screw x 12 + 2</p>
<p>(G)</p>  <p>4*25mm Screw x 6 + 2</p>	<p>(H)</p>  <p>4*16mm Screw x 45 + 2</p>	<p>(I)</p>  <p>Nail leg x 9 + 2</p>	<p>(J)</p>  <p>Metal shelf support x 16 + 2</p>
<p>(K)</p>  <p>Spring door support x 8 + 2</p>	<p>(L)</p>  <p>L bracket x 4</p>	<p>(M)</p>  <p>Hook x 6</p>	<p>(N)</p>  <p>Hinges x 7</p>
<p>(O)</p>  <p>Handle x 3</p>	<p>(P1)</p>  <p>4*12mm Screw x 2</p>	<p>(P2)</p>  <p>4*50mm Screw x 2</p>	<p>(P3)</p>  <p>Wall plug x 2</p>
<p>(P4)</p>  <p>PVC strip x 2</p>			

Tools required

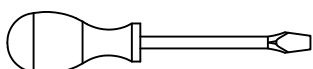

Philips screwdriver
(medium & large)

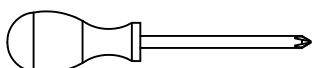

Using Camlocks

Step 1

Connect the male camlock as directed in the assembly instructions using a screwdriver.

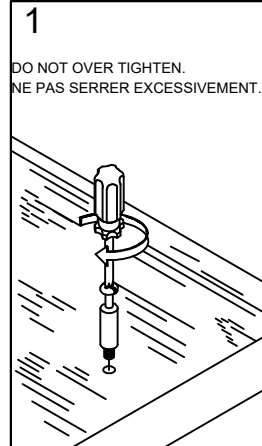

Step 2

Push the male camlock into the entry hole.

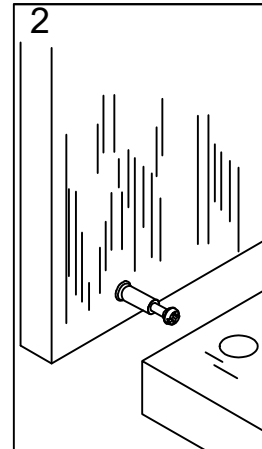

Step 3

Insert the female camlock as shown in the instruction.

Note: ensure that the arrow on the top of the camlock points towards the entry hole for the male camlock.

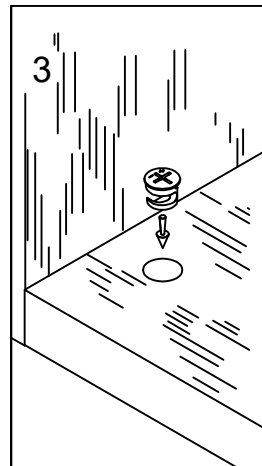

Step 4

Turn the female camlock clockwise with a screwdriver.

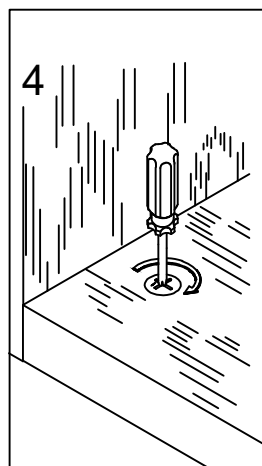

You should feel a click when the camlock is locked in place.

The joint is now secure.



Components - Parts

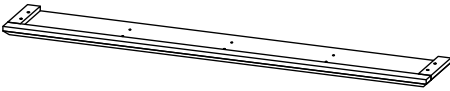
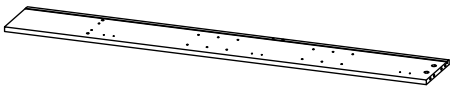
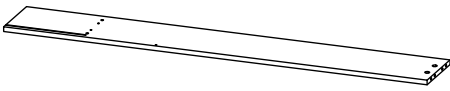
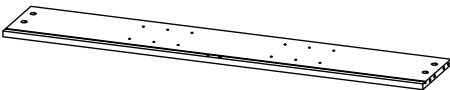
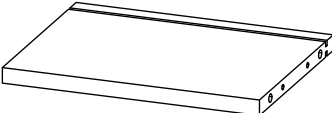
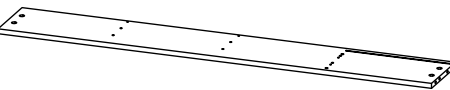
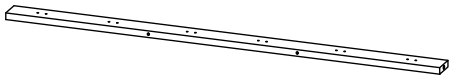

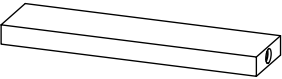
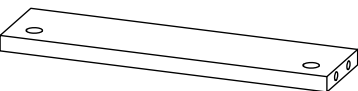
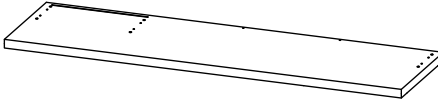
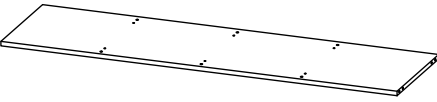
Please check you have all the panels listed below.

		
<p>① Up Top Panel 1400*216*30 1 PC</p>	<p>② Up Side Panel (L) 1370*196*15 1 PC</p>	<p>③ Up Side Panel (R) 1370*196*15 1 PC</p>
		
<p>④ Up Center Panel 1105*195*15 1 PC</p>	<p>⑤ Up Center Panel 250*190*15 3 PCS</p>	<p>⑥ Up Middle Panel 1330*195*15 1 PC</p>
		
<p>⑦ Up Back Bone 994*50*15 1 PC</p>	<p>⑧ Back Bone Long 855*50*15 2 PCS</p>	<p>⑨ Back Bone Short 200*50*15 2 PCS</p>
		
<p>⑩ Back Bone (L) 321*80*15 1 PC</p>	<p>⑪ Down Top Panel 1400*392*30 1 PC</p>	<p>⑫ Down Bottom Panel 1330*370*15 1 PC</p>

Components - Parts

<p>⑬ Down Side Panel (L) 420*370*15 1 PC</p>	<p>⑭ Down Side Panel (R) 420*370*15 1 PC</p>	<p>⑮ Down Center Panel (L) 317*370*15 1 PC</p>
<p>⑯ Down Center Panel (R) 317*370*15 1 PC</p>	<p>⑰ Down Center Panel (C) 317*370*15 1 PC</p>	<p>⑱ Up Back Panel 260*331*2.5 4 PCS</p>
<p>⑲ Back Center (L) 1115*331*2.5 1 PC</p>	<p>⑳ Back Center (R) 1135*341*2.5 3 PCS</p>	<p>㉑ Down Back Panel 1358*347*2.5 1 PC</p>
<p>㉒ Up Shelf Panel 320*168*15 2 PCS</p>	<p>㉓ Down Shelf Panel 320*360*15 2 PCS</p>	<p>㉔ Up Door Panel 1114*346*15 1 PC</p>

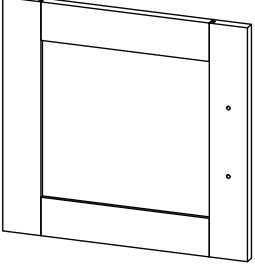
Components - Parts

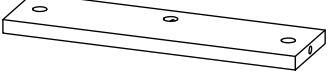
<p>(25)</p>  <p>A perspective drawing of a rectangular door panel with a recessed center section and a vertical strip on the right side. Two small circles are visible on the right side, representing screws or fasteners.</p>	<p>(26)</p>  <p>A perspective drawing of a long, thin, rectangular metal leg with a slightly tapered end. Two small circles are visible on the top surface, representing screws or fasteners.</p>	<p>(27)</p>  <p>A perspective drawing of a shorter, wider, rectangular metal leg with a slightly tapered end. Two small circles are visible on the top surface, representing screws or fasteners.</p>
<p>Down Door Panel 328*346*15 2 PCS</p>	<p>Cabinet Leg 1330*88*15 2 PCS</p>	<p>Center Leg 326*88*15 1 PC</p>

Assembly Instructions

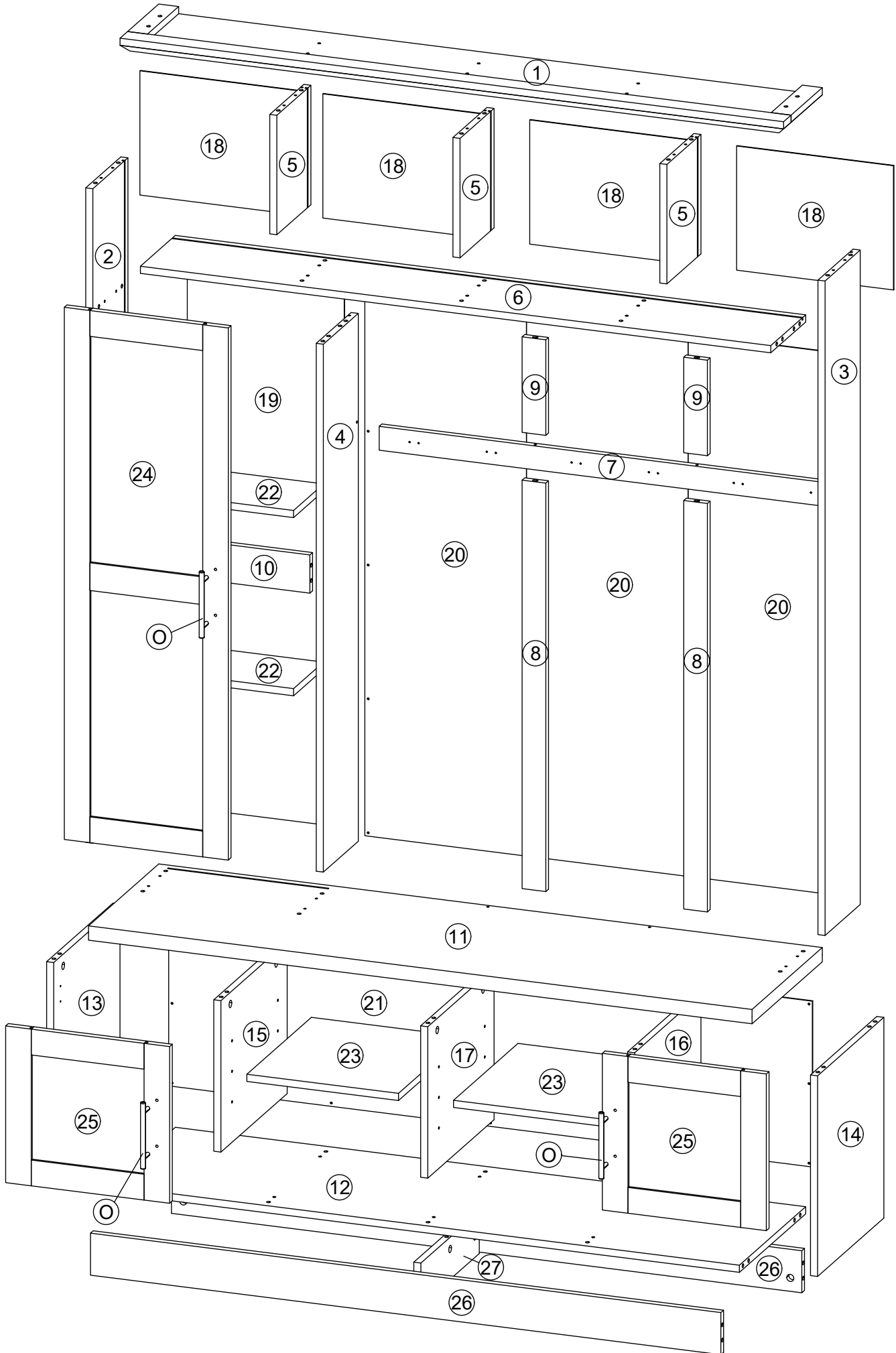

STEP 3

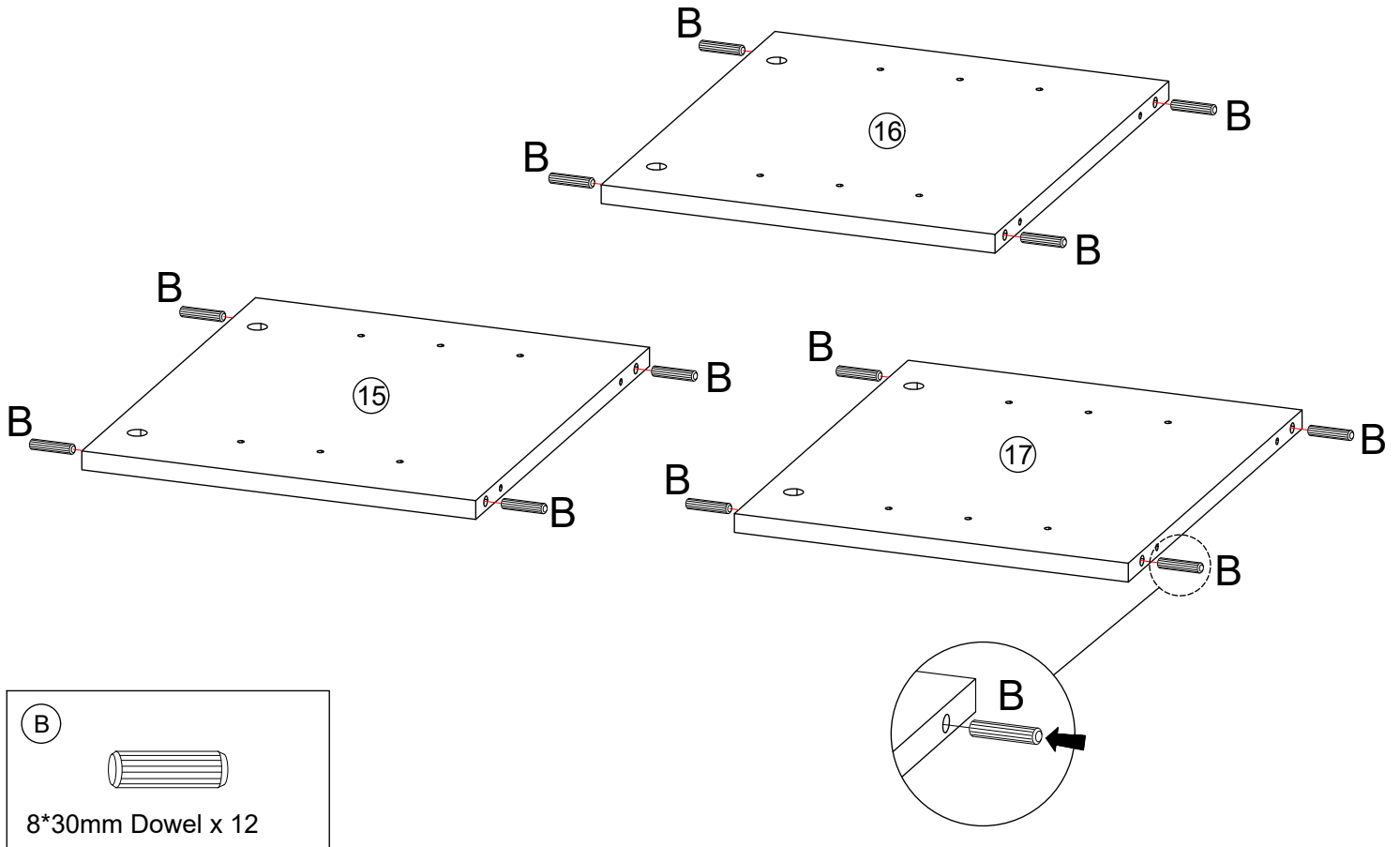

STEP 4

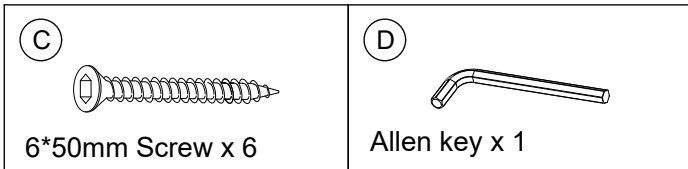
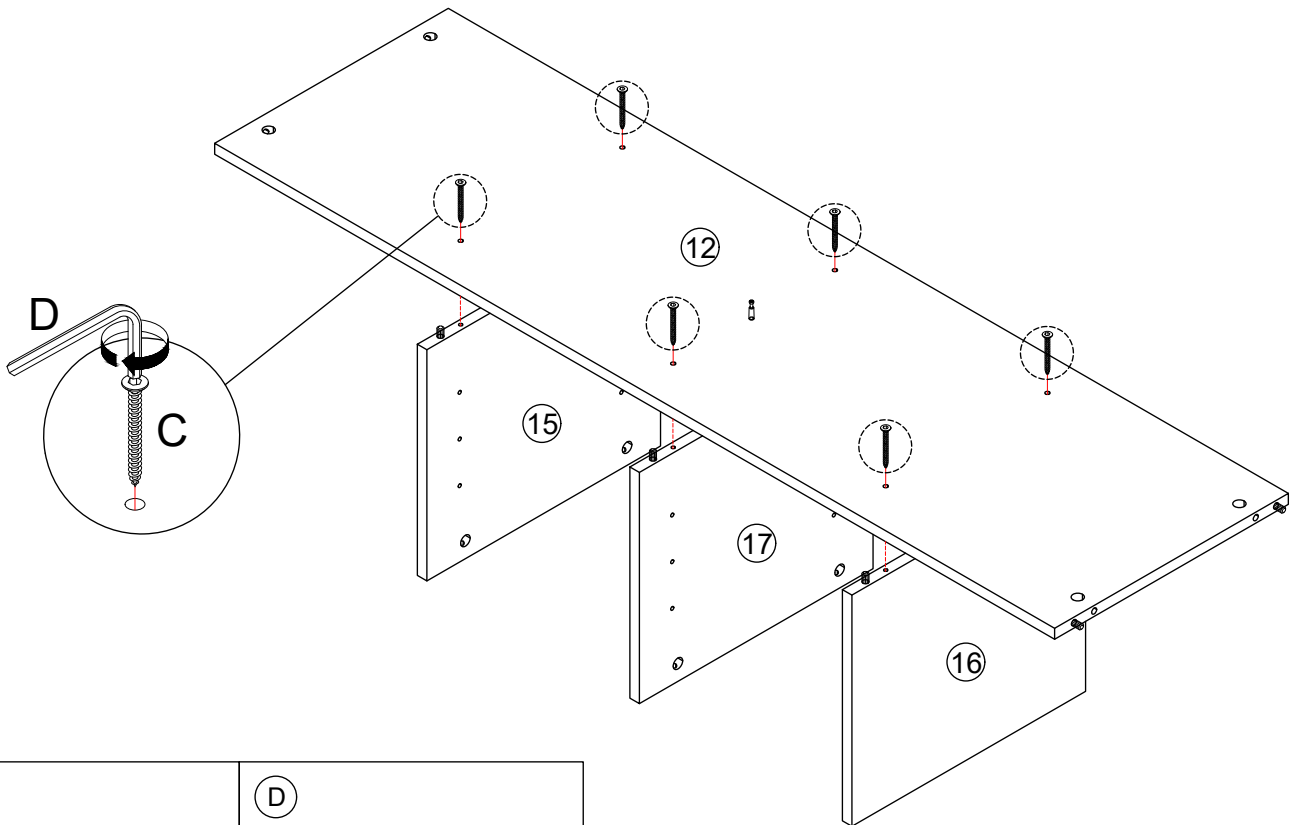

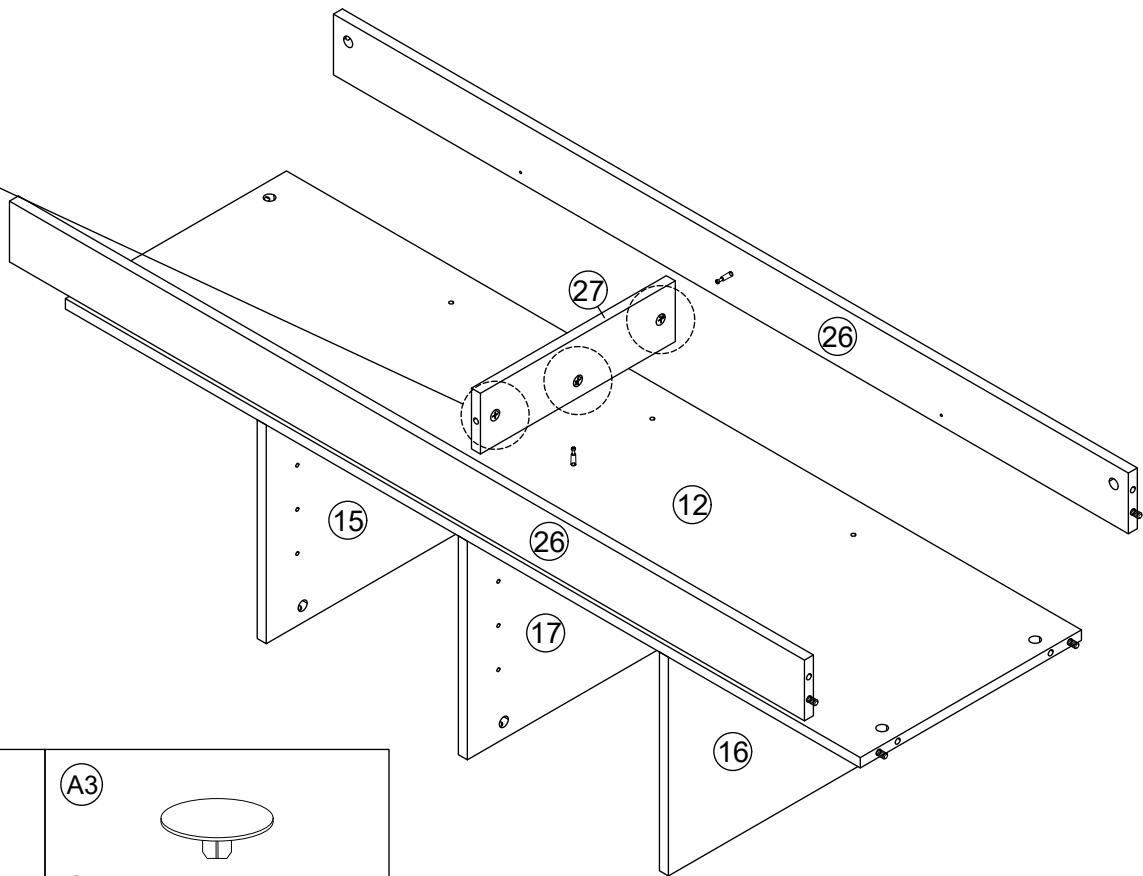
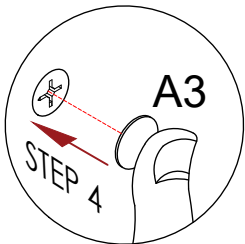
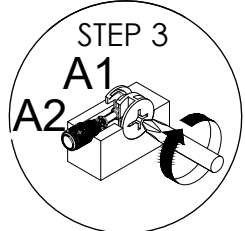
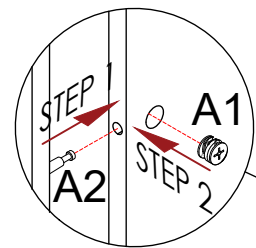

STEP 5

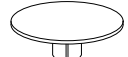

<p>(A1)</p>  <p>Cam lock x 3</p>	<p>(A3)</p>  <p>Cam cap x 3</p>
--	---

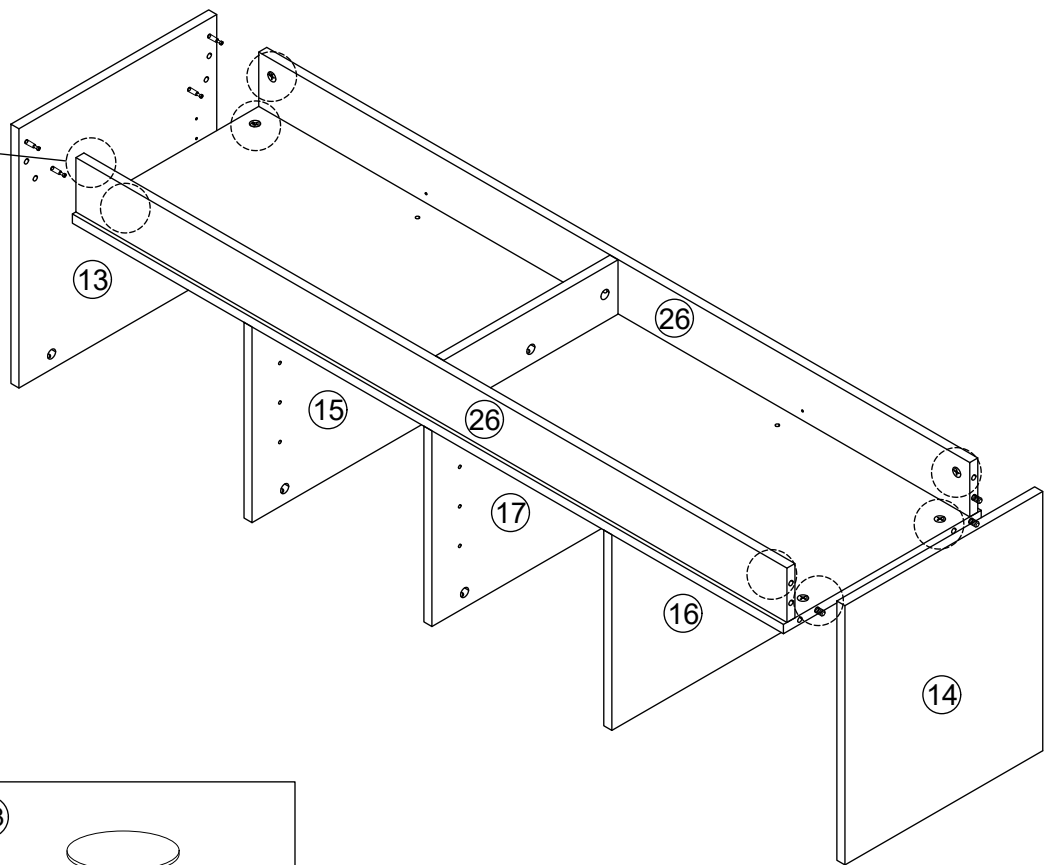
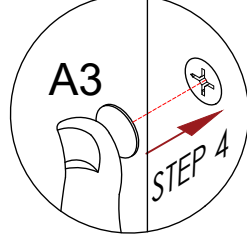
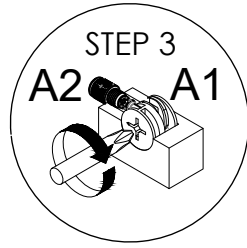
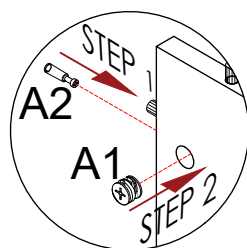
STEP 6



<p>(A1)</p>  <p>Cam lock x 8</p>	<p>(A3)</p>  <p>Cam cap x 8</p>
---	--

STEP 7

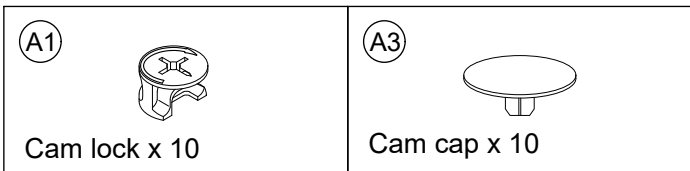
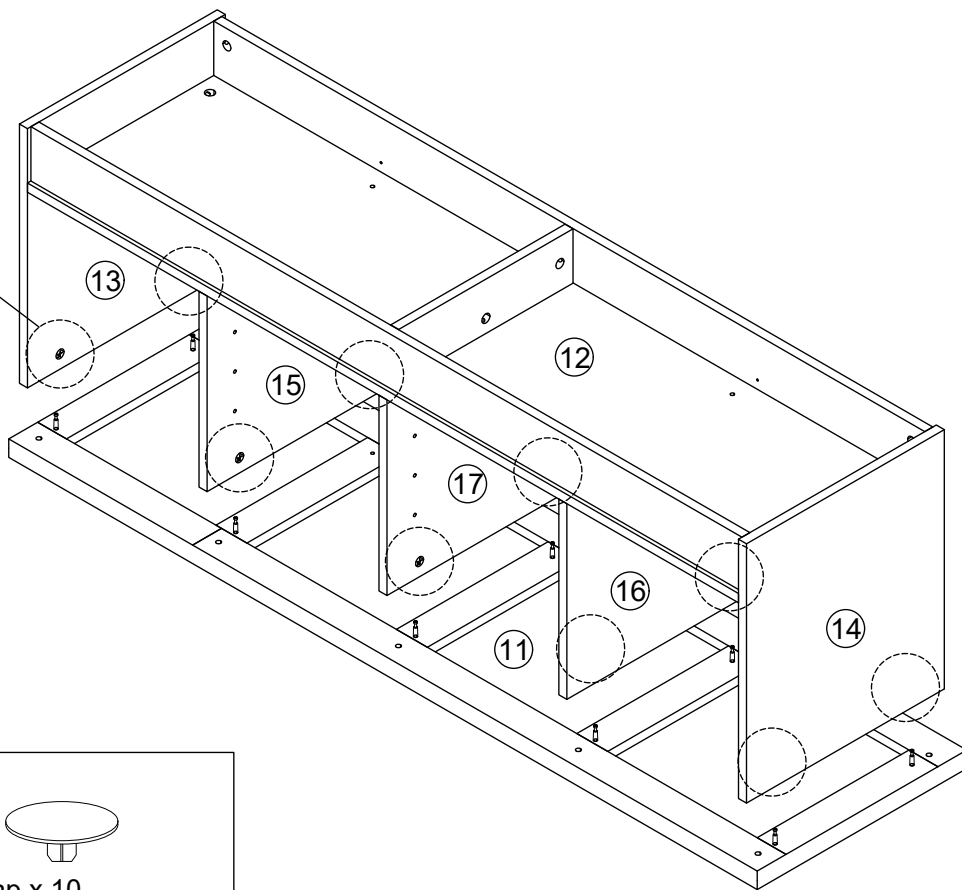
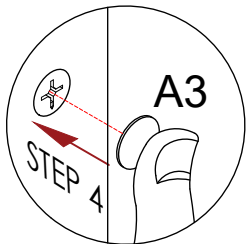
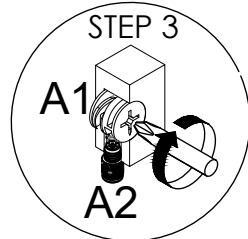
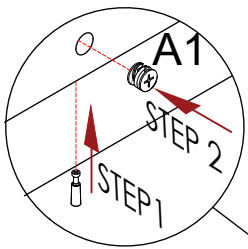

STEP 8

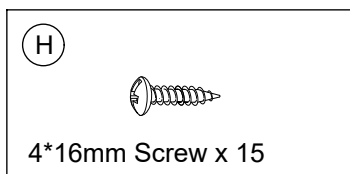
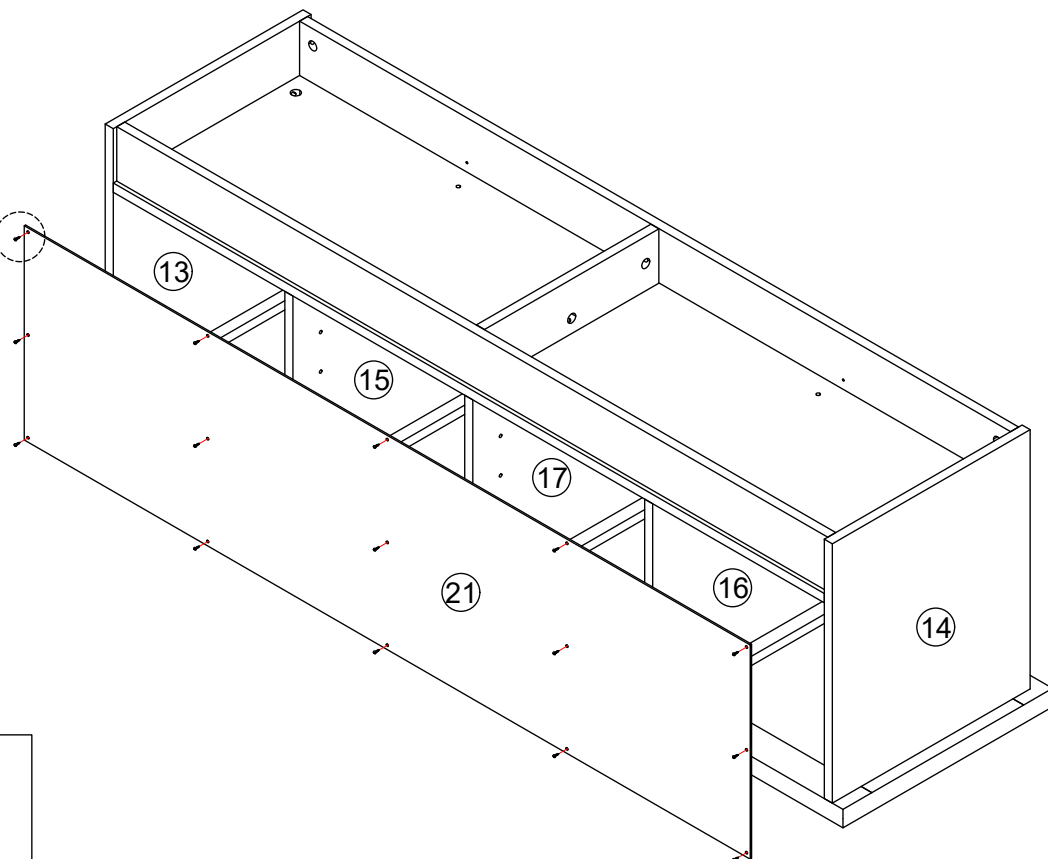
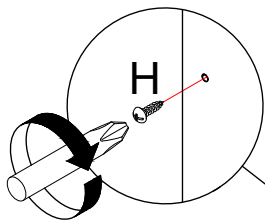

STEP 9

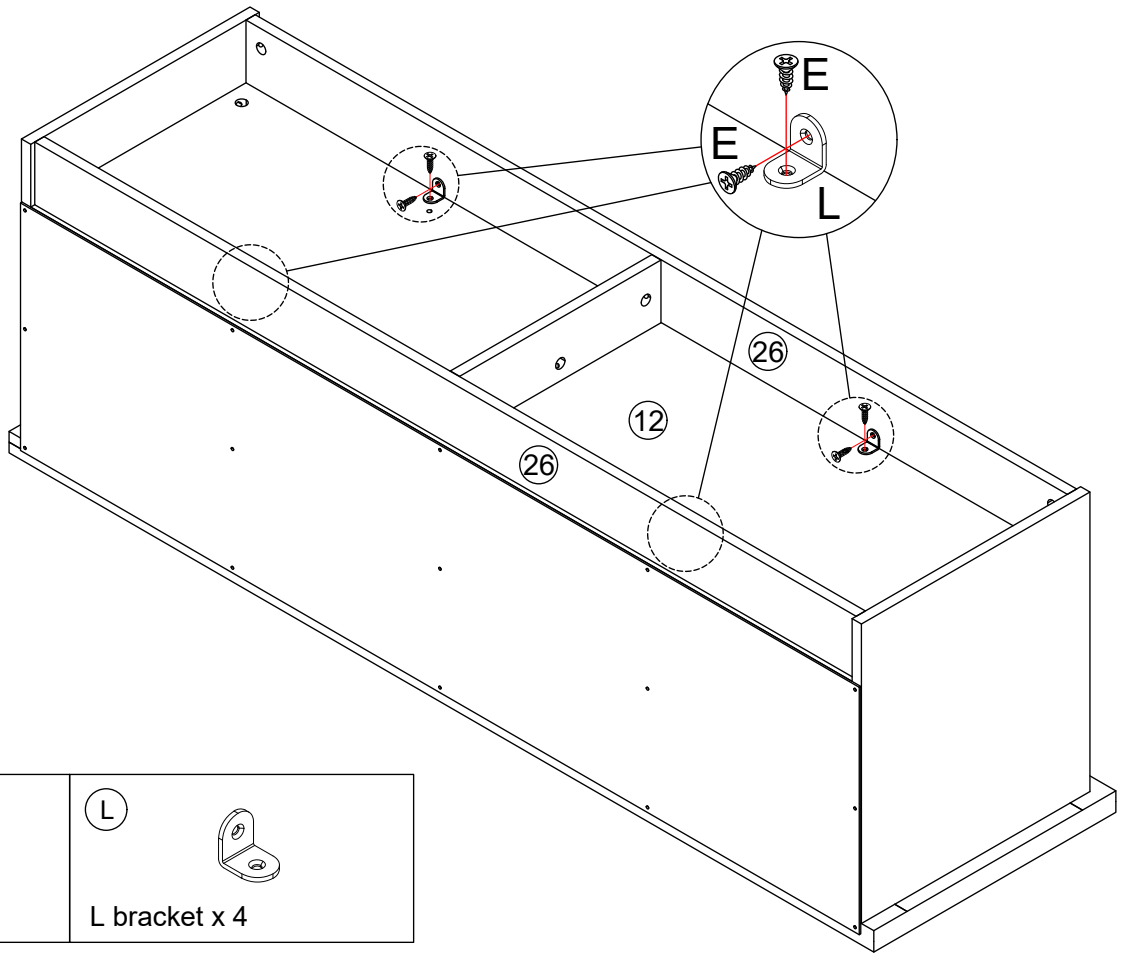

STEP 10

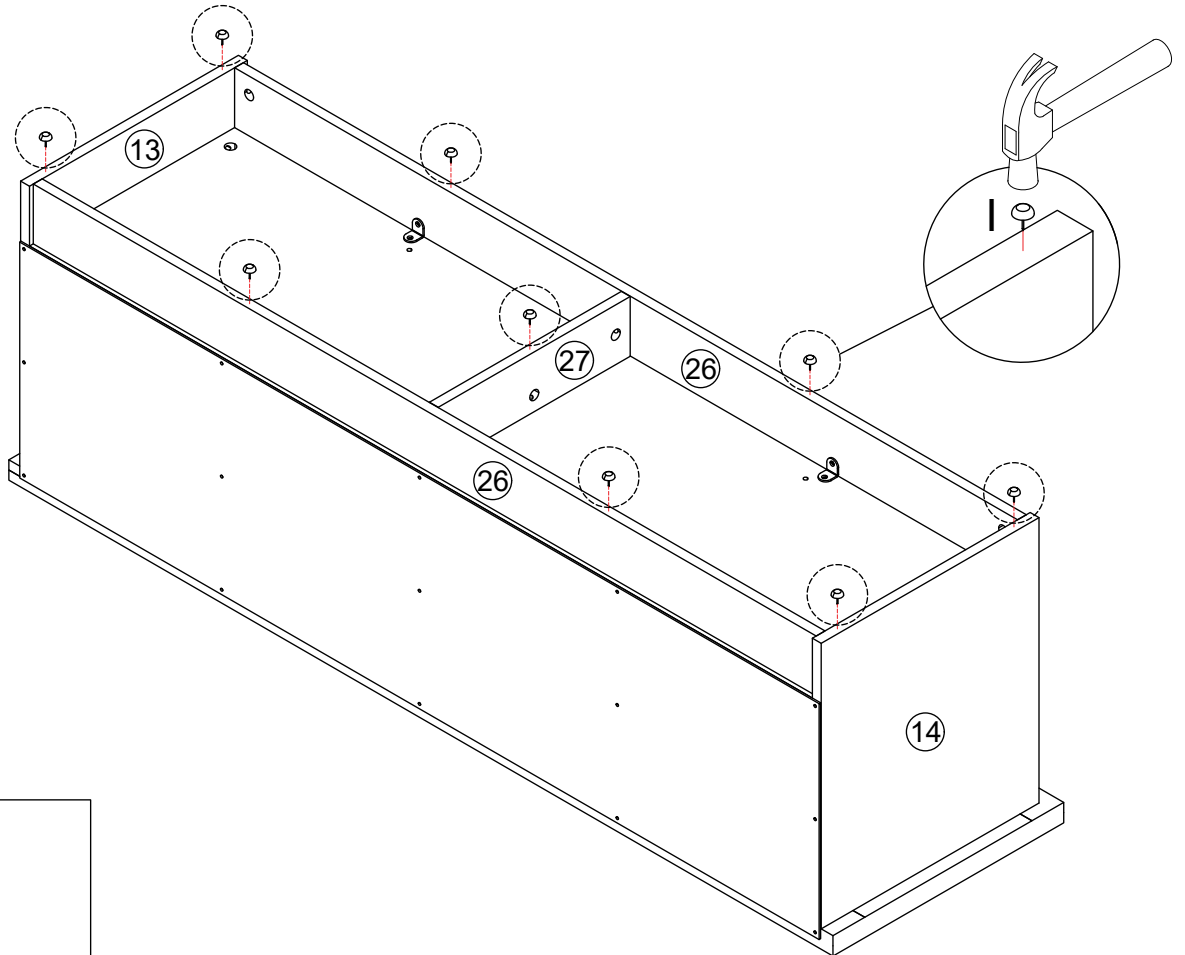

STEP 11

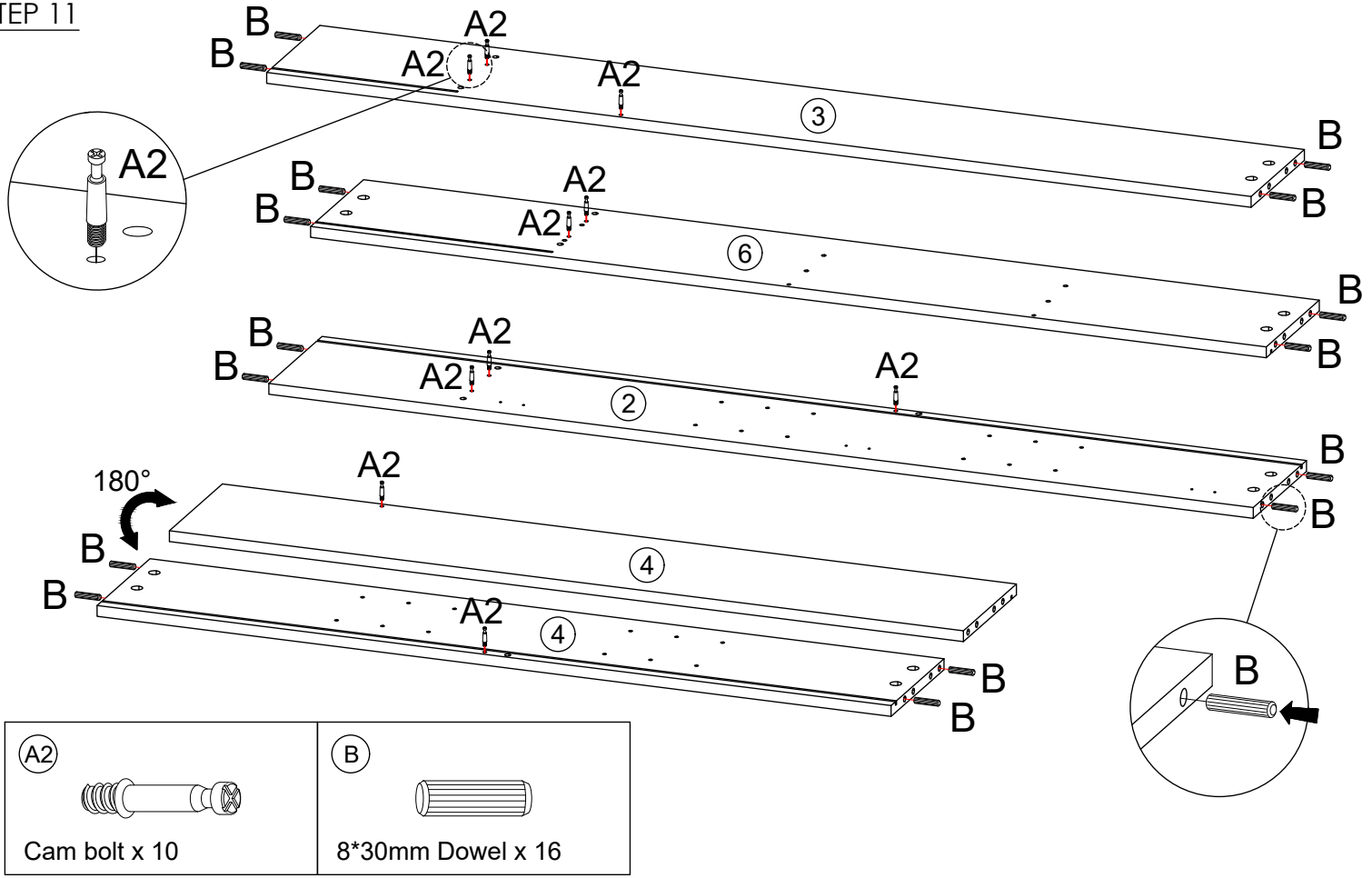

STEP 12

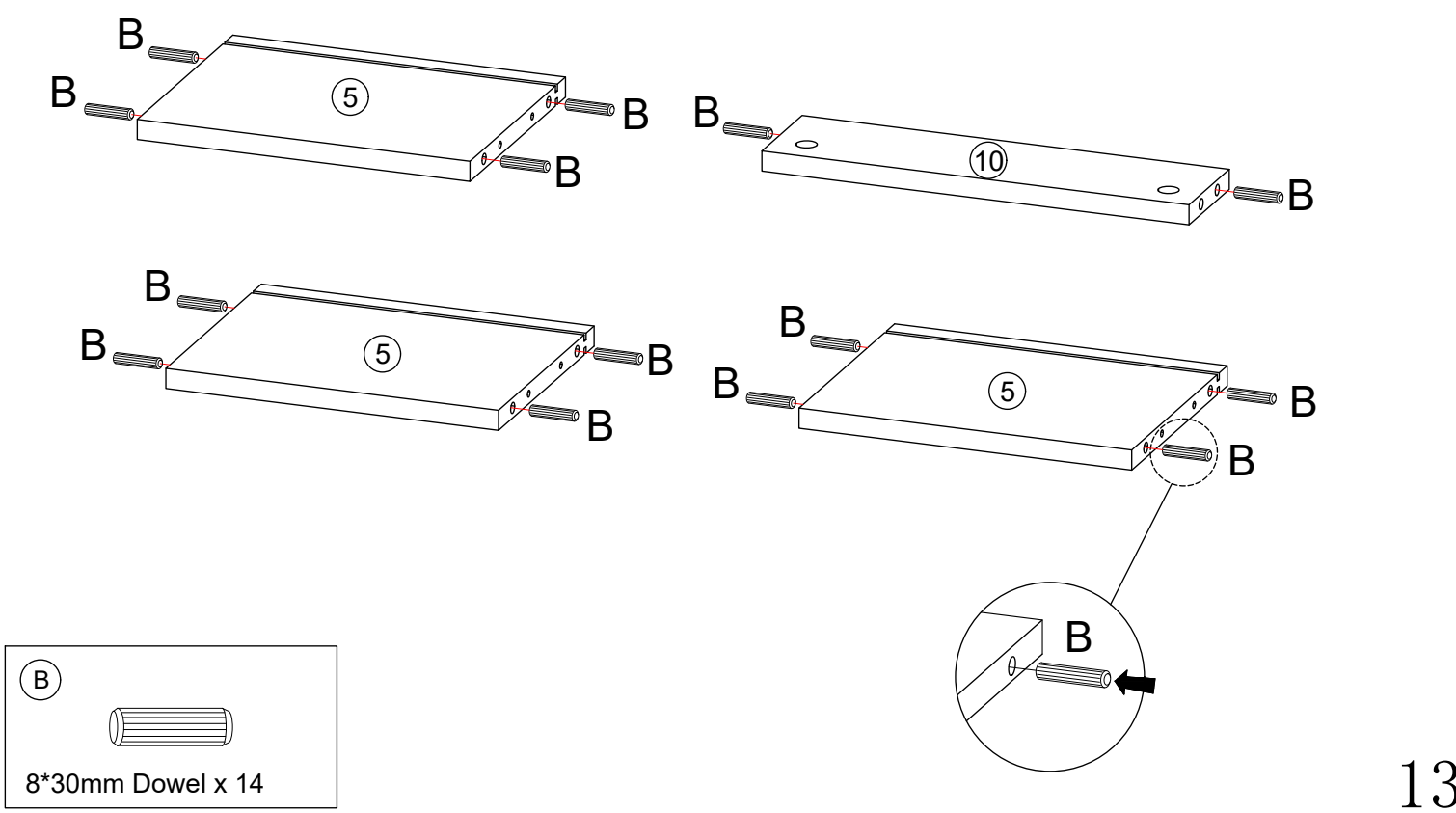

STEP 13

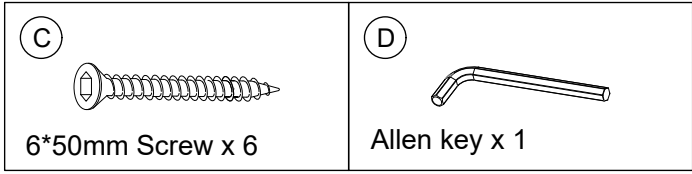
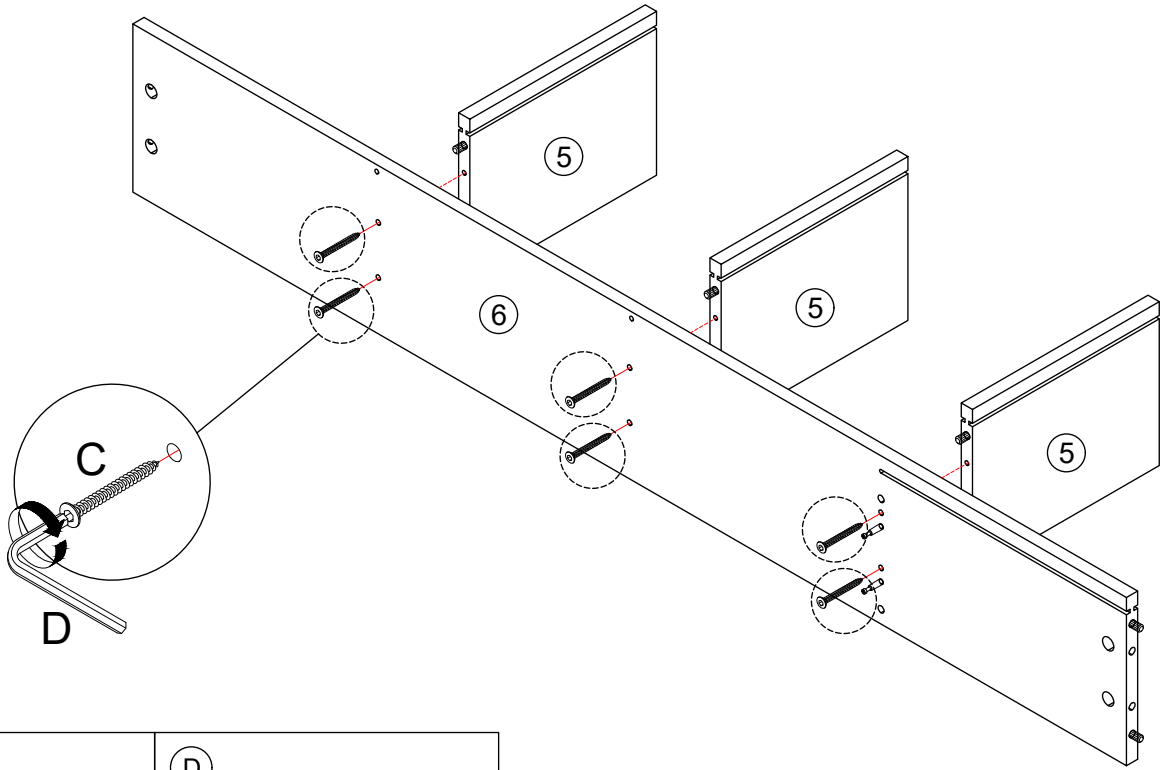

STEP 14

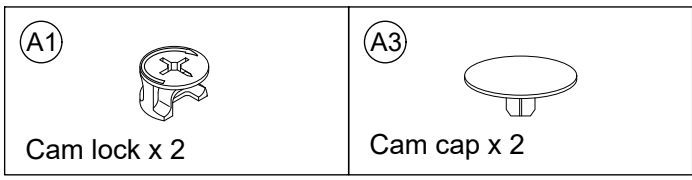
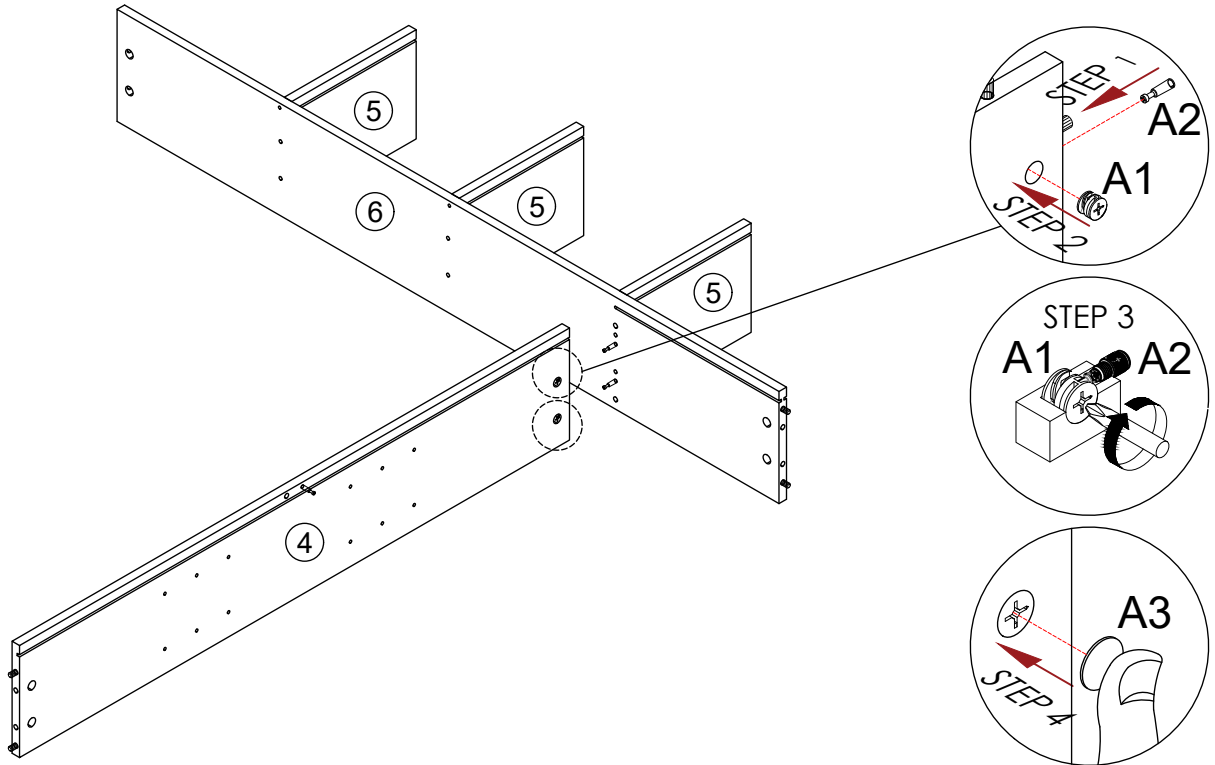

STEP 15

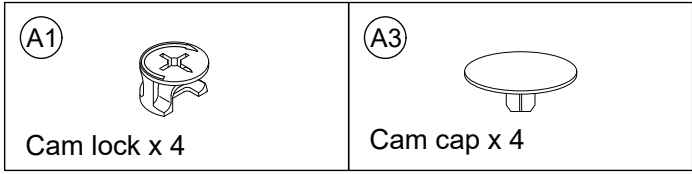
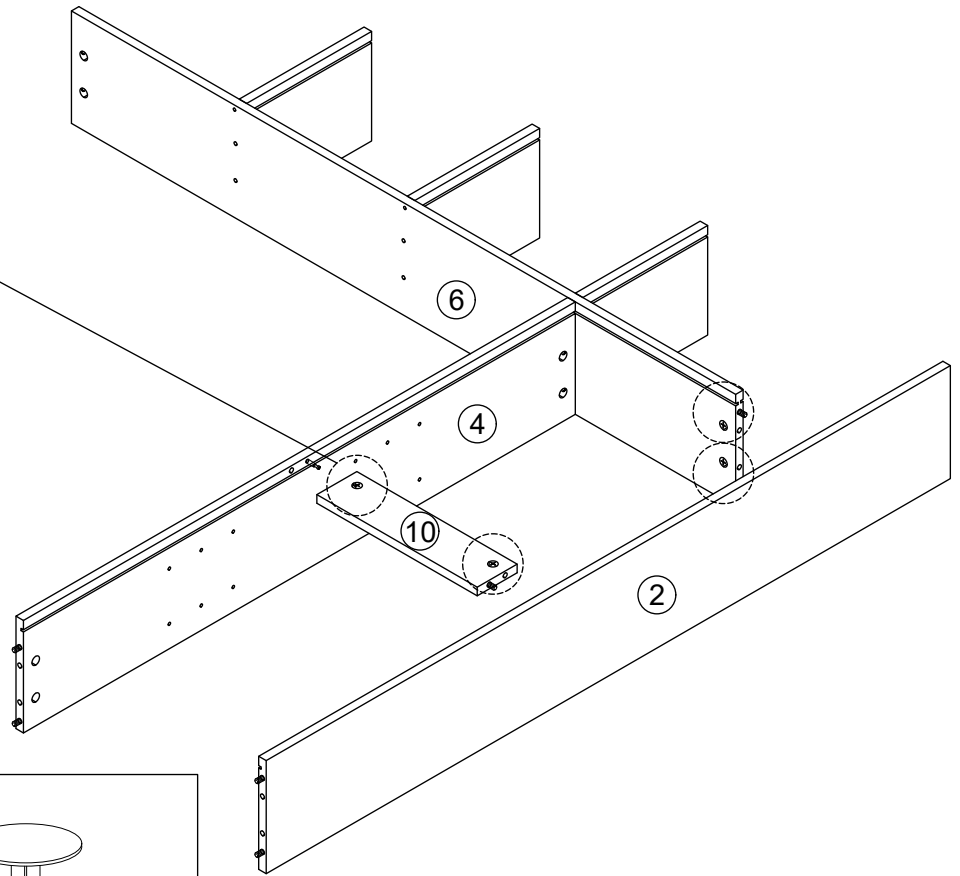
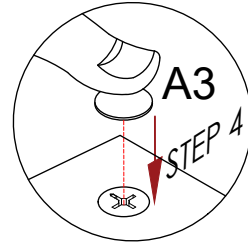
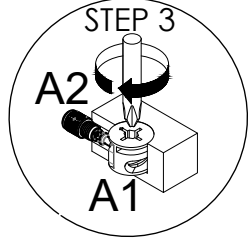
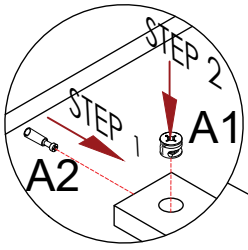

STEP 16

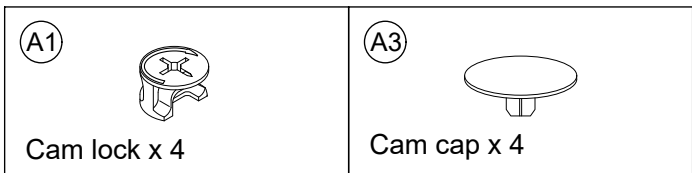
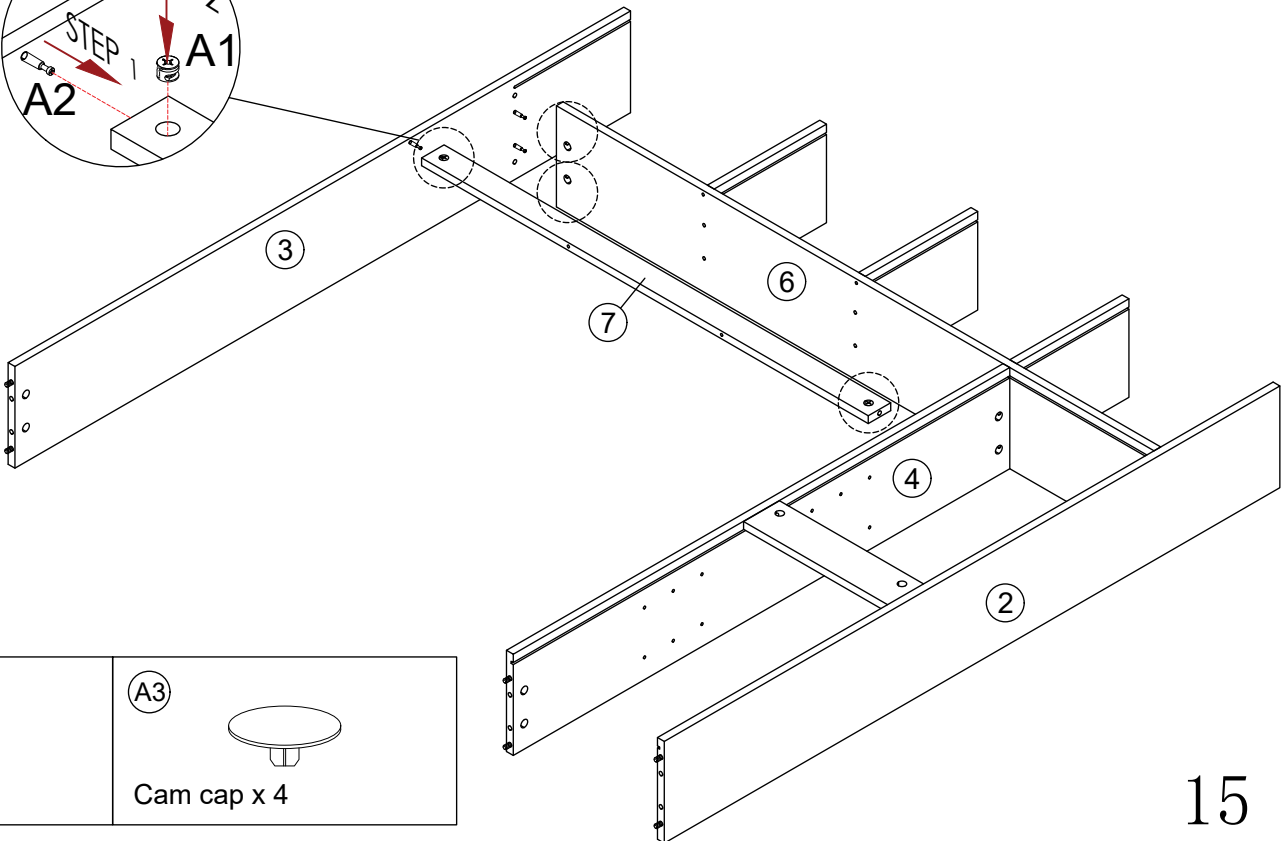
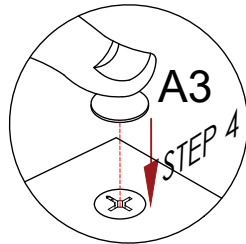
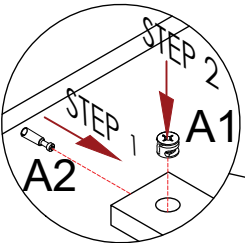
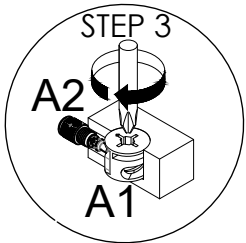

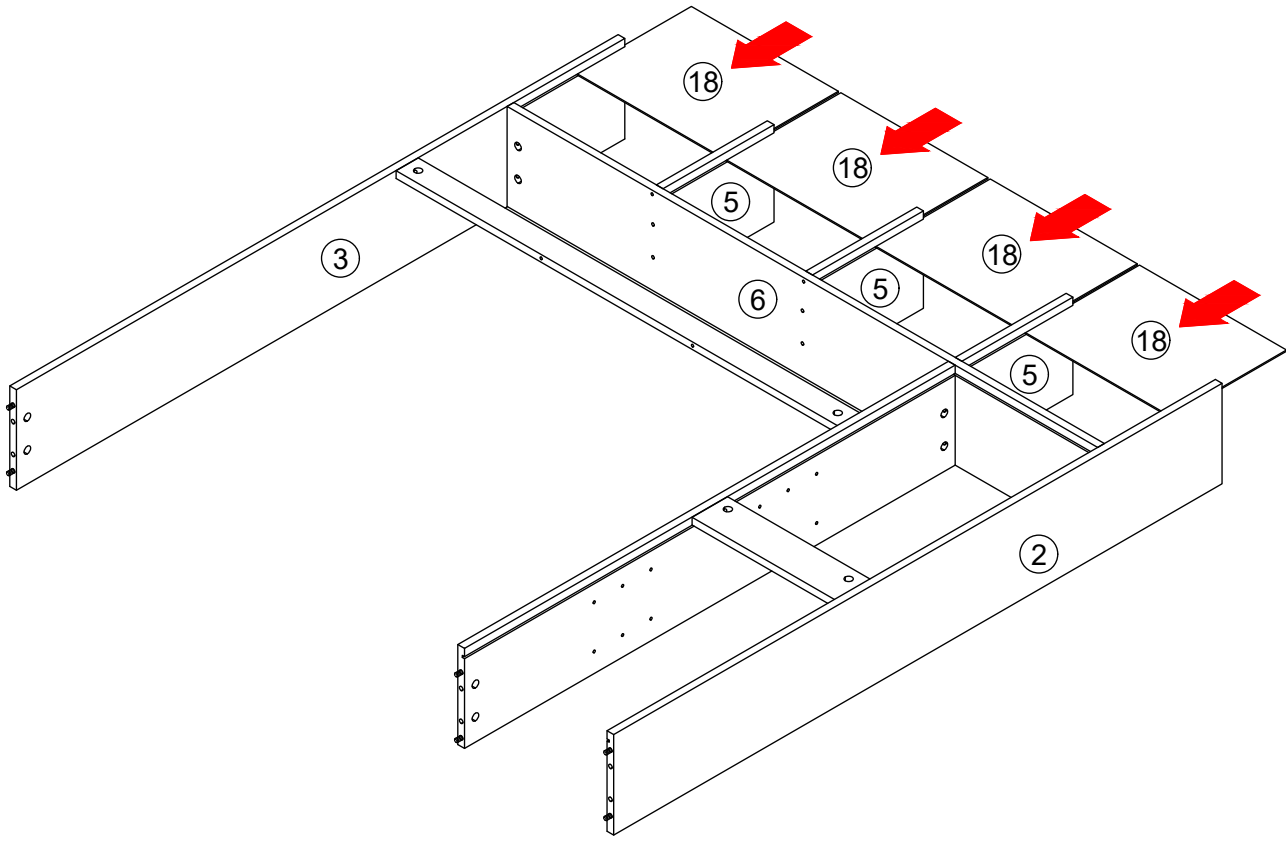

STEP 17

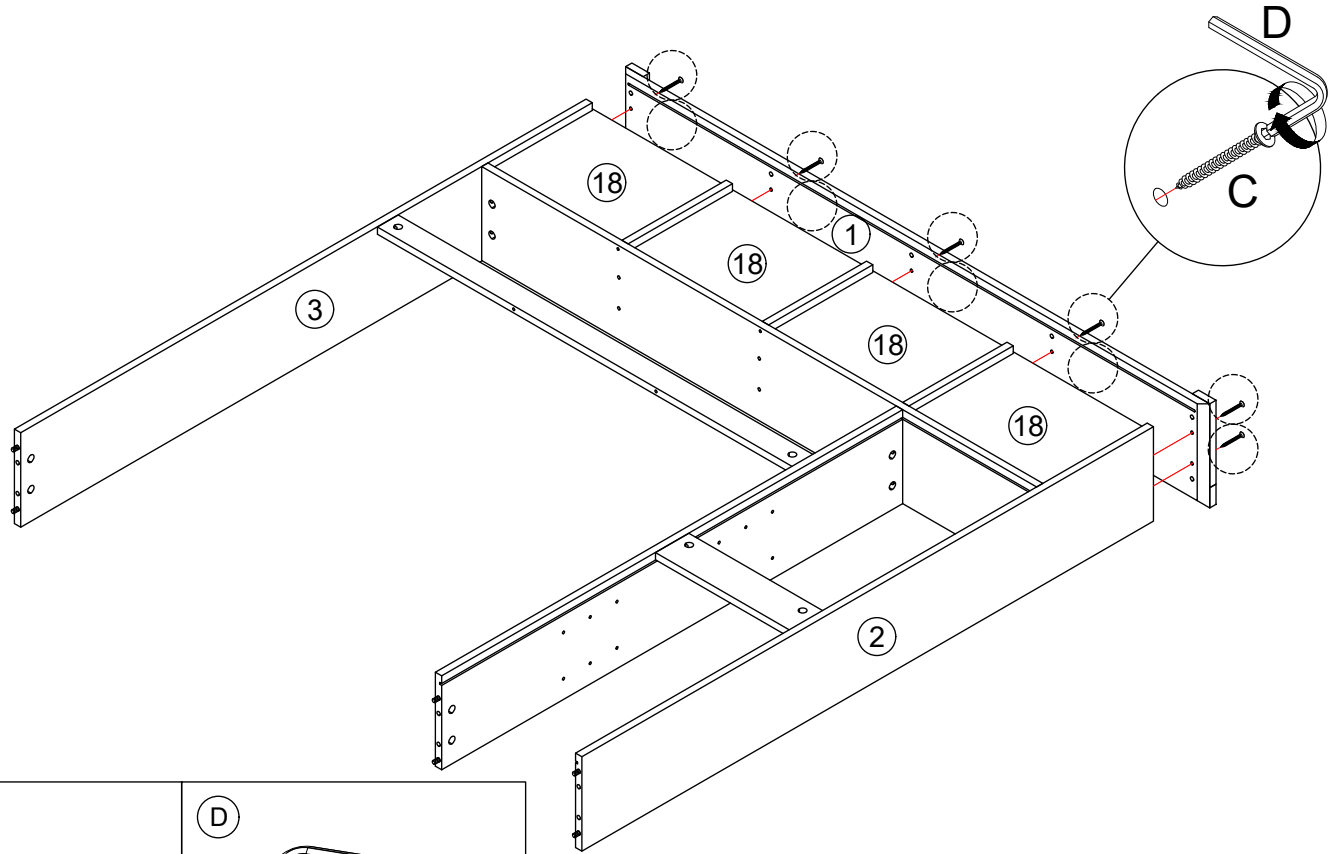

STEP 18

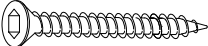

<p>(C)</p>  <p>6*50mm Screw x 10</p>	<p>(D)</p>  <p>Allen key x 1</p>
---	---

STEP 19

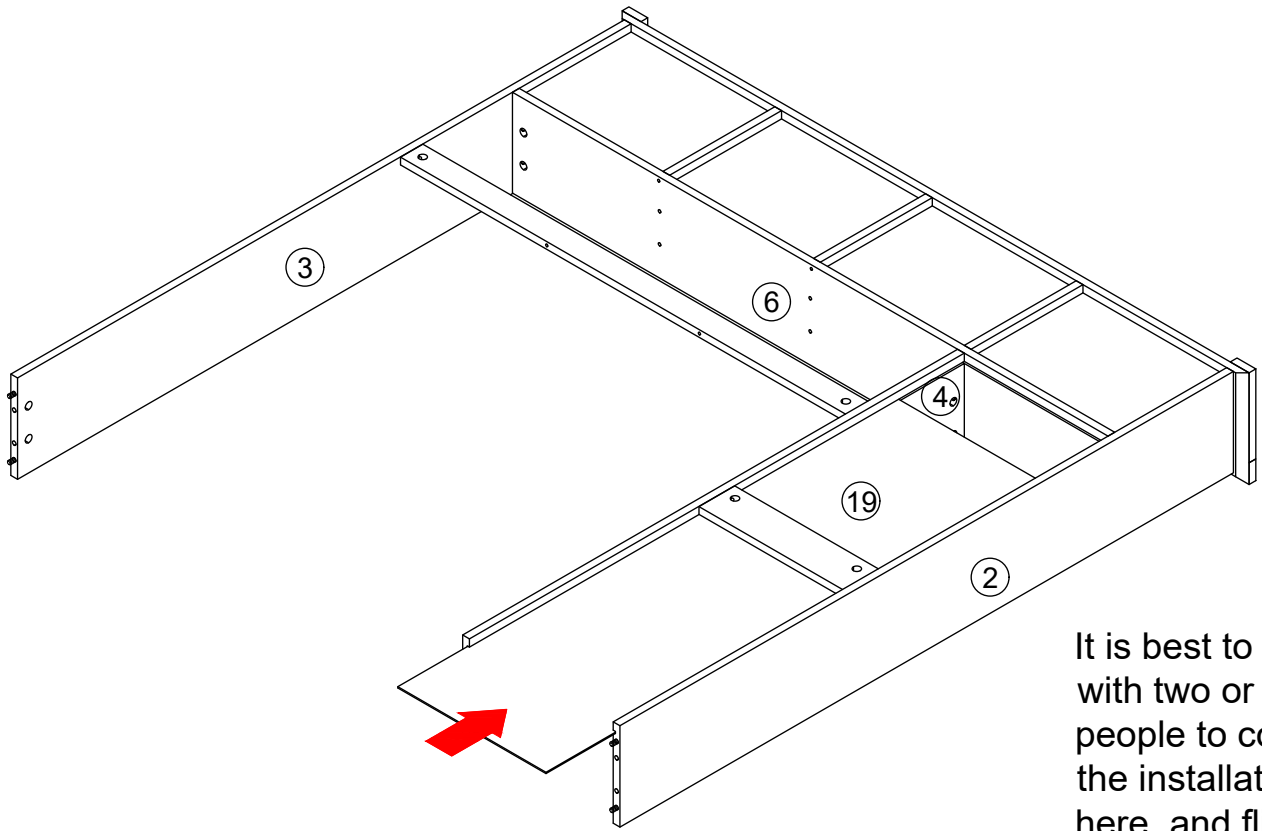

It is best to work with two or more people to complete the installation here, and flip carefully please.

STEP 20

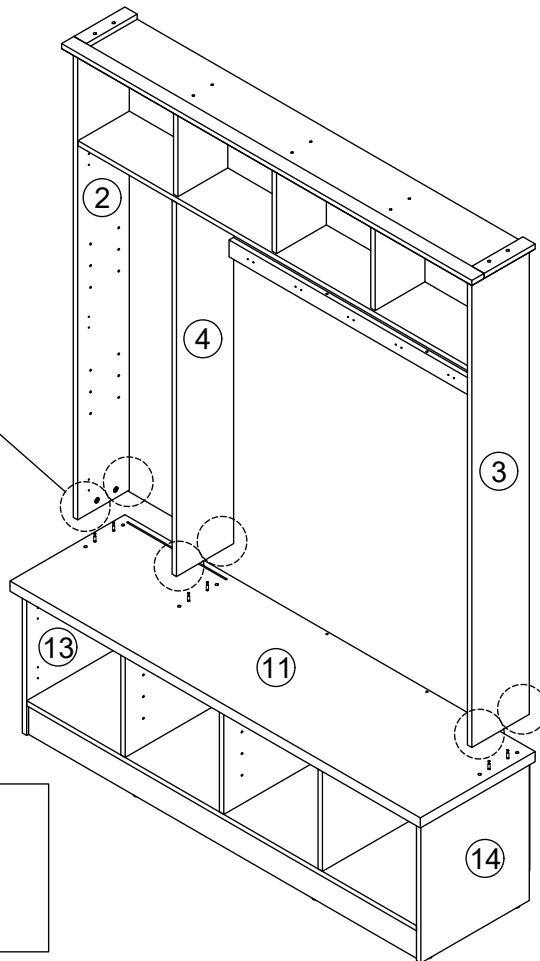
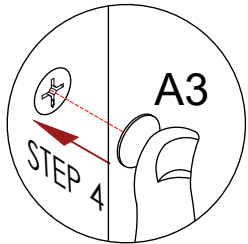
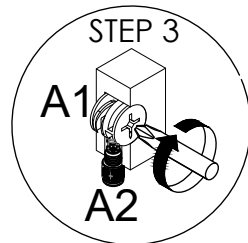
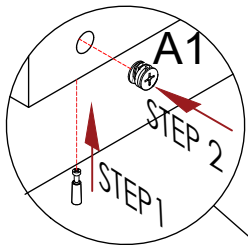

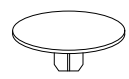
<p>(A1)</p>  <p>Cam lock x 6</p>	<p>(A3)</p>  <p>Cam cap x 6</p>
---	--

STEP 21

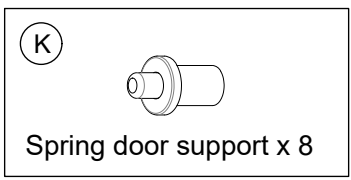
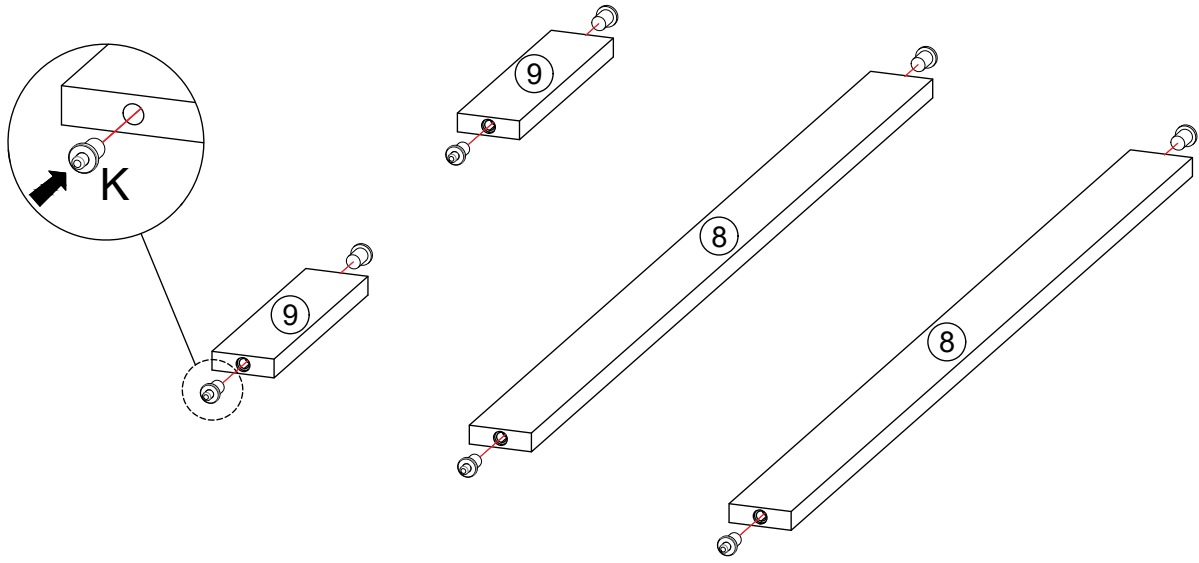

STEP 22

Press hardware K and then slot in to the hole at cabinet.

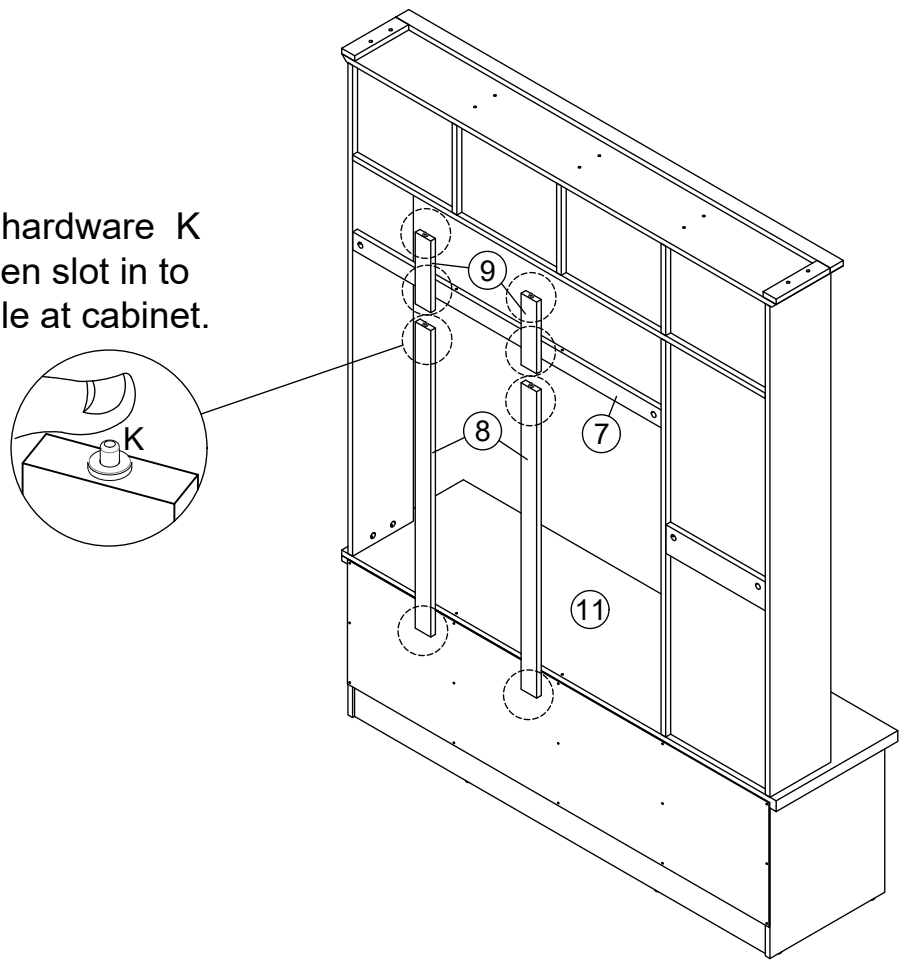

STEP 23

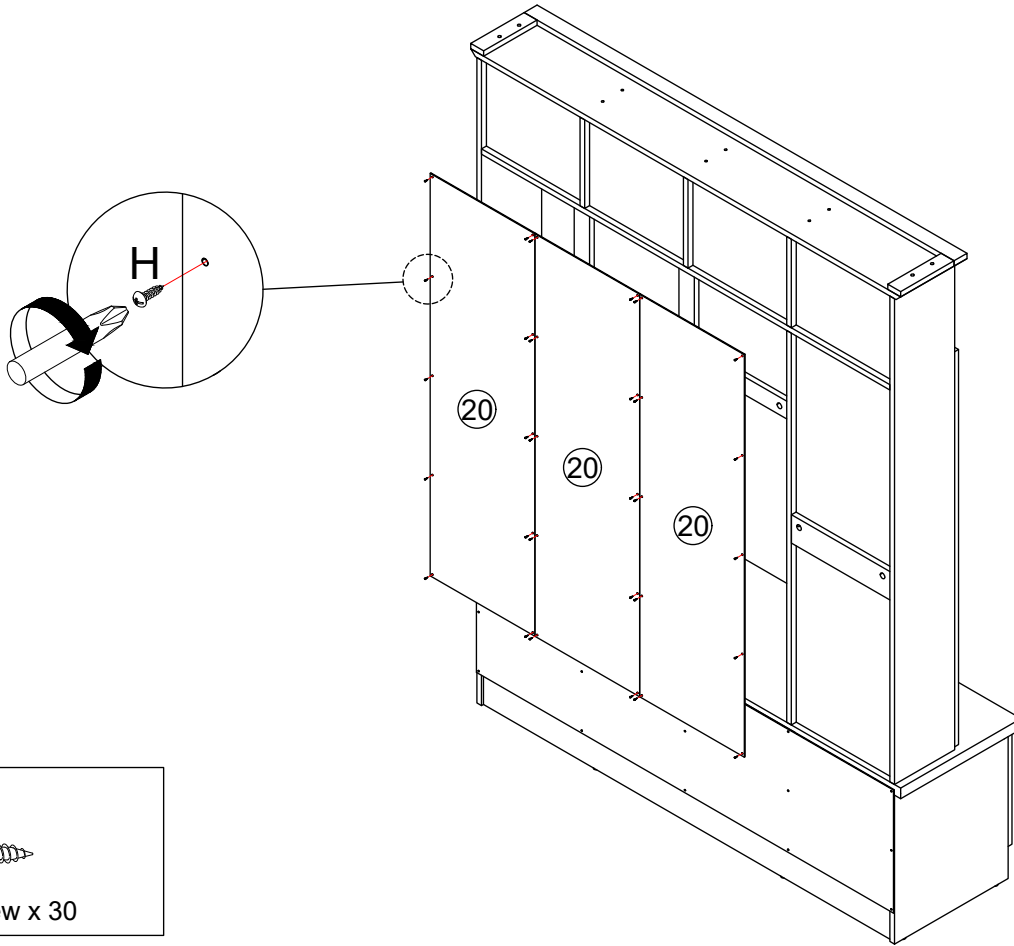

STEP 24

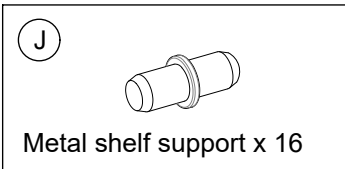
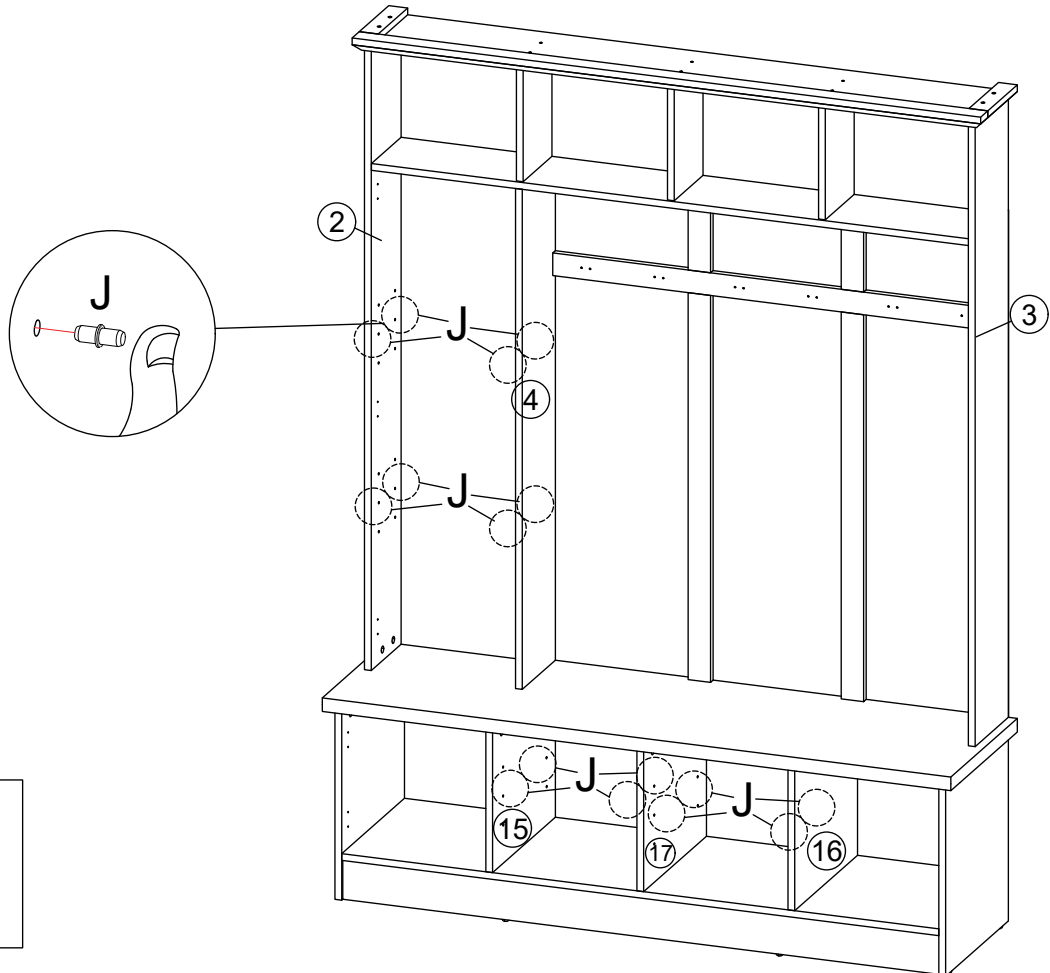

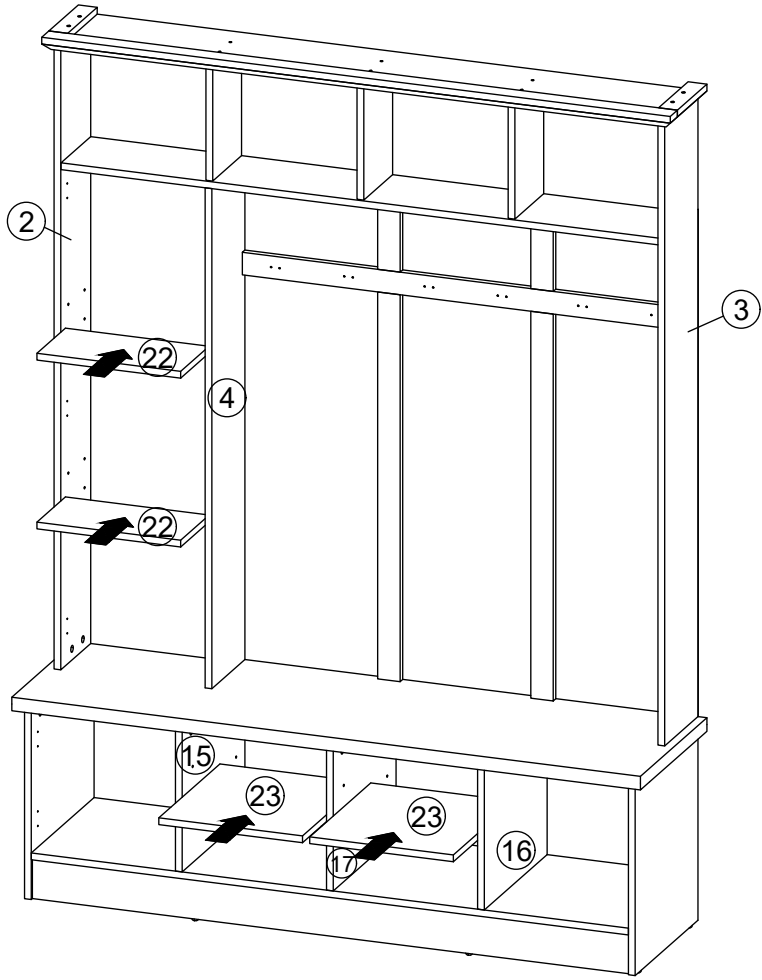

STEP 25

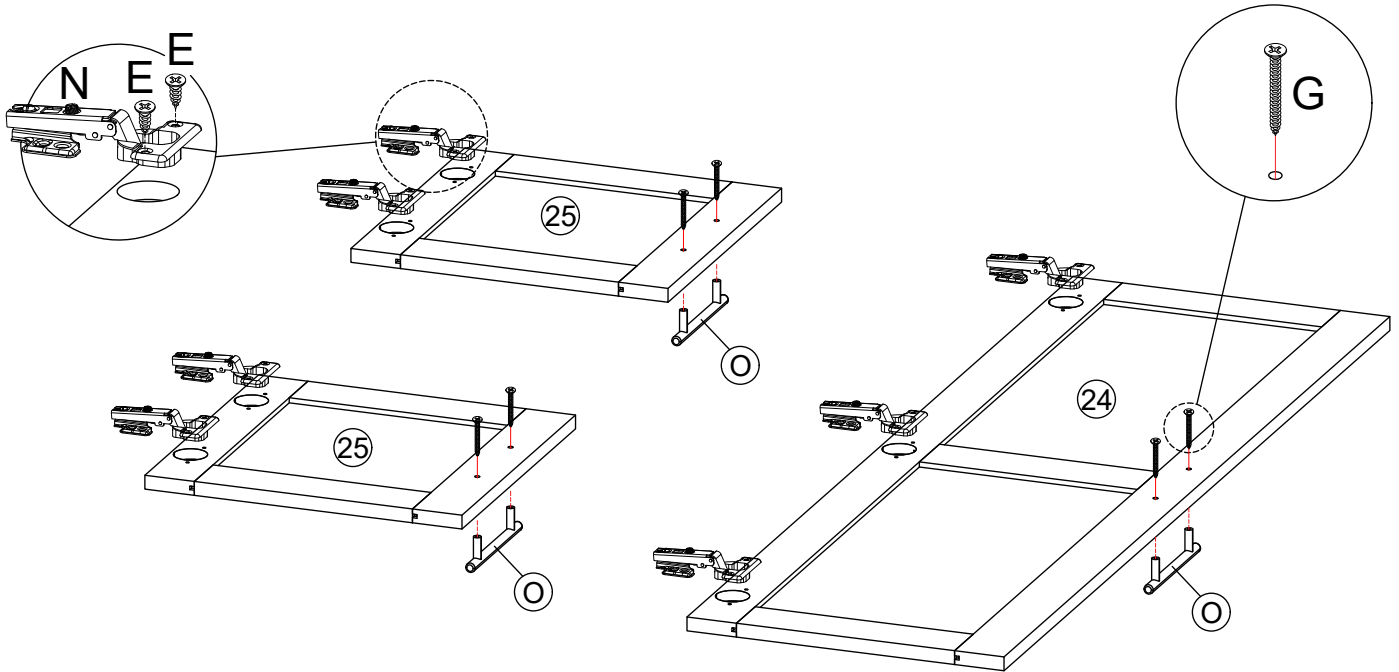

STEP 26

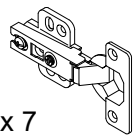

<p>(E)</p>  <p>3.5*16mm Screw x 14</p>	<p>(N)</p>  <p>Hinges x 7</p>	<p>(G)</p>  <p>4*25mm Screw x 6</p>	<p>(O)</p>  <p>Handle x 3</p>
---	--	---	--

STEP 27

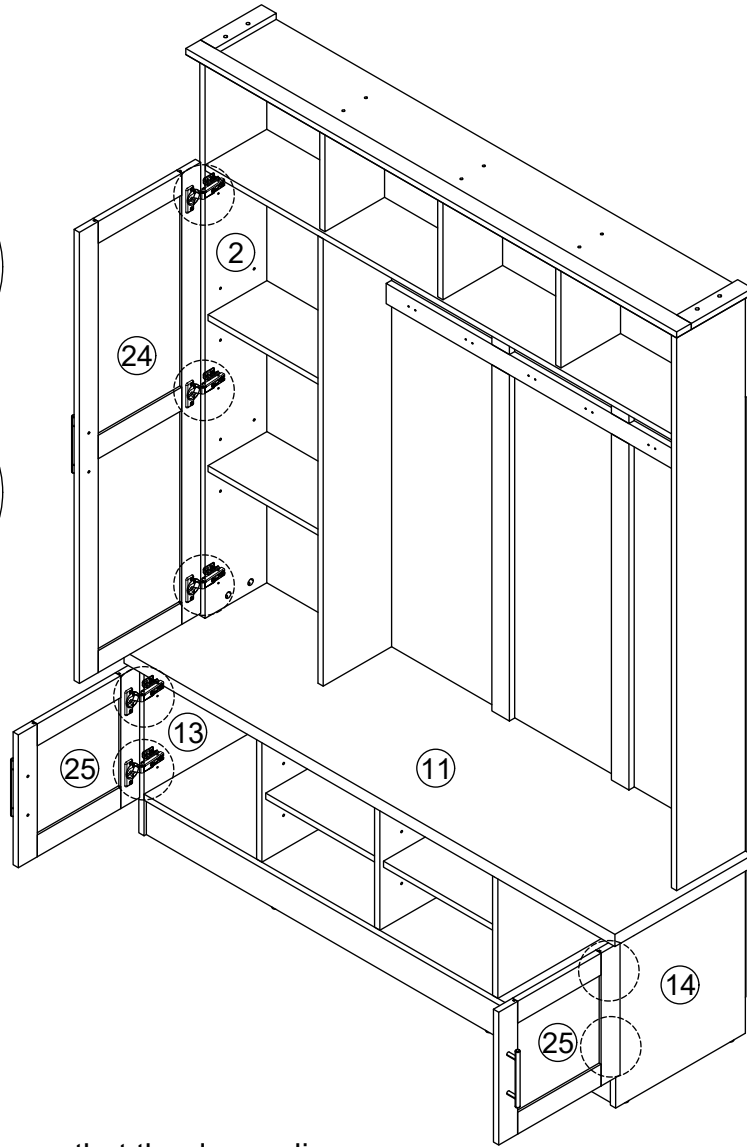
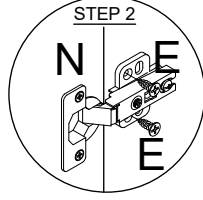
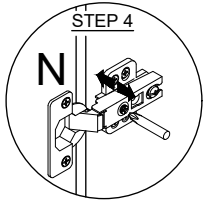
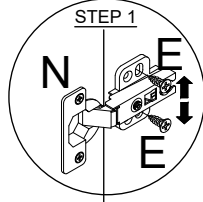
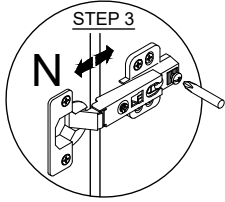

HINGE ADJUSTMENT GUIDE

It may be necessary to adjust the hinges so that the doors align. Use the instructions below as a guide.

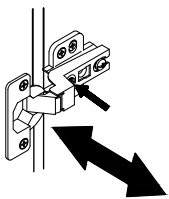

To adjust the door horizontal loosen the screw as shown by turning clockwise or anti-clockwise.

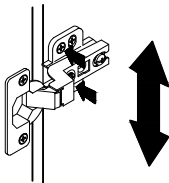

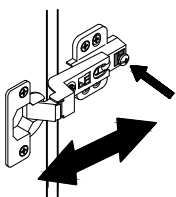

To adjust the door vertically loosen the screw as shown and move up and down as needed.



To adjust the gap from the door to the main frame turn the screw clockwise or anti-clockwise as needed.

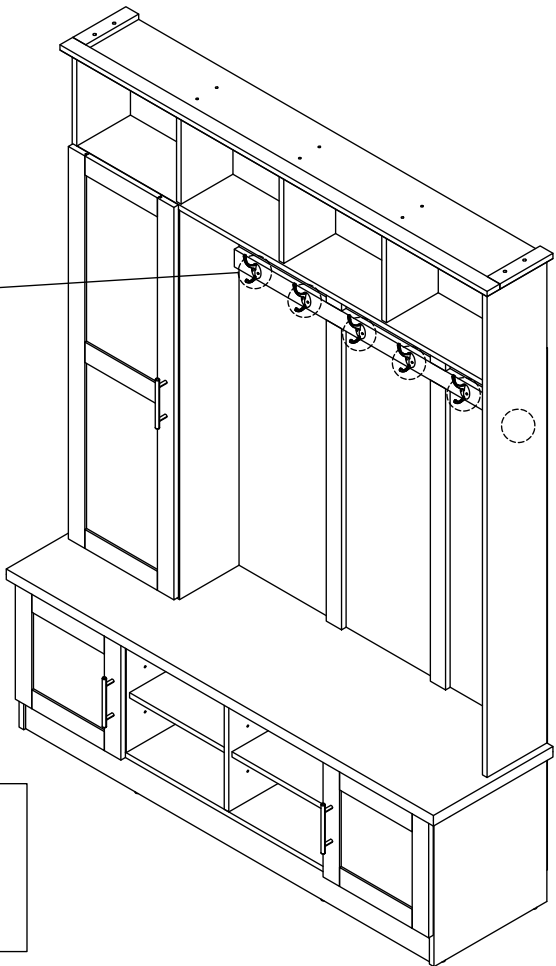
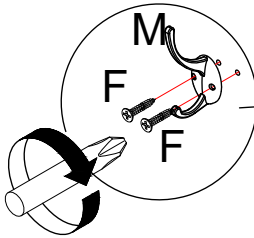

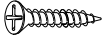
STEP 28

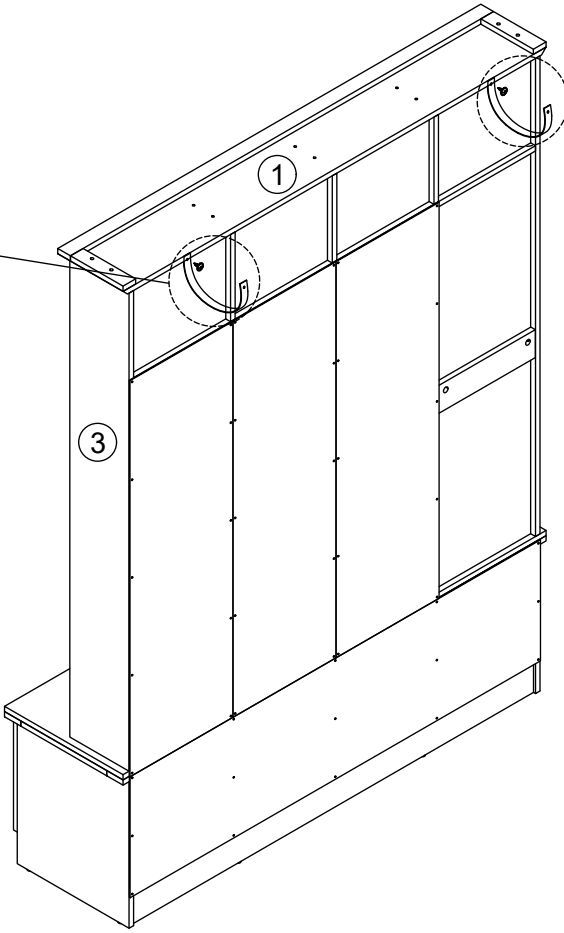
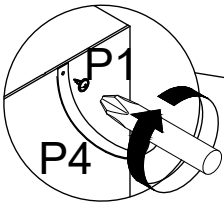

<p>(F)</p>  <p>3.5*16mm Screw x 12</p>	<p>(M)</p>  <p>Hook x 6</p>
--	---

STEP 29



<p>(P1)</p>  <p>4*12mm Screw x 2</p>	<p>(P4)</p>  <p>PVC strip x 2</p>
---	--

STEP 30

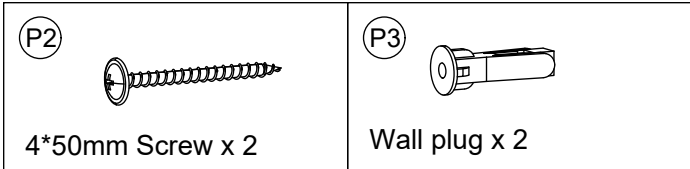
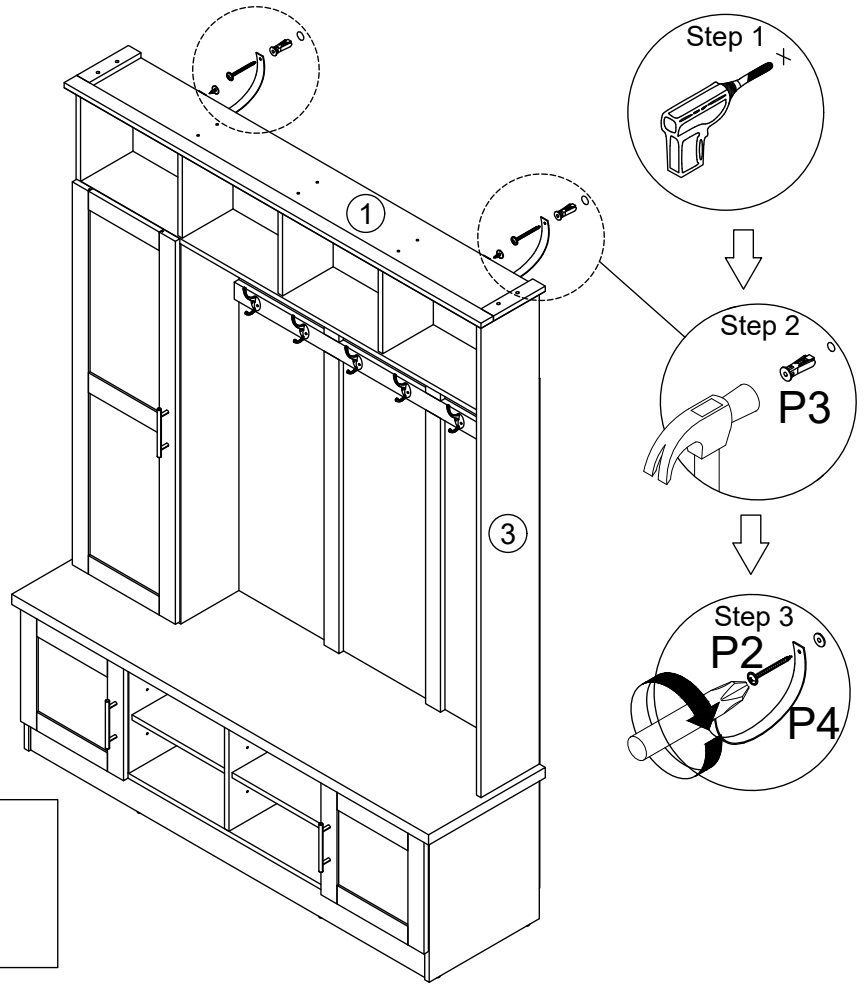

STEP 31

