



RICHMOND HEADBOARD



ASSEMBLY INSTRUCTIONS

Before assembling your Headboard, please read through these instructions carefully. Familiarize yourself with the different parts.

ATTENTION! If you receive a damaged or defective item, please contact Atlantic Furniture at service@atlanticfurniture.com 1-800-955-3726 / M-F 9:00-5:00 EST

PARTS LIST

- 1 HEADBOARD PANEL 1 PC
- 2 LEFT LEG 1 PC
- 3 RIGHT LEG 1 PC

Instructions apply for all sizes of bed
TWIN > FULL > QUEEN > KING

HARDWARE

- A JCB M6 X 120mm(3 3/4") - 4 pcs
Spare - 1 pc
- B JCB M6 X 70mm(2 3/4") - 4 pcs
Spare - 1 pc
- C Barrel Nut - 8 pcs
Spare - 1 pc
- D Split Washer - 4 pcs
Spare - 1 pc
- E Flat Washer - 4 pcs
Spare - 1 pc
- F JCB M6 X 25mm(1") - 4 pcs
Spare - 1 pc
- G Allen Wrench - 1pc
Spare - 1pc

Step 1

Attach the legs (2)(3) to headboard panel (1), using JCB (A) and barrel nut (C). Tighten with the Allen wrench (G).

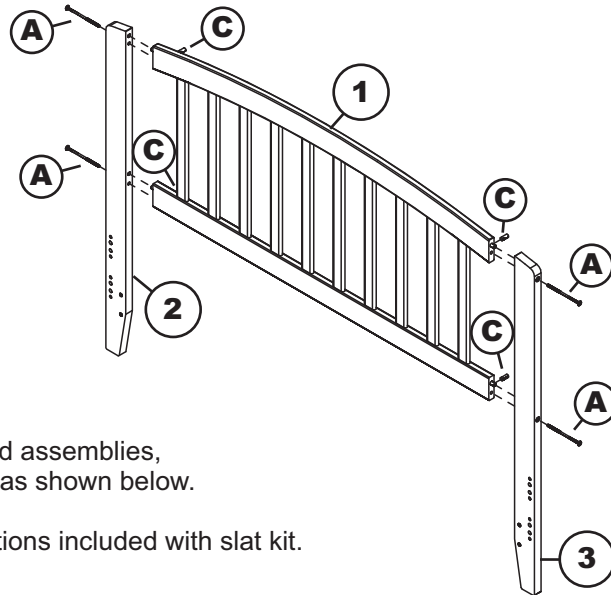

Step 2

Attach bed frame assemblies to the headboard assemblies, using JCB M6 X 70mm (B) and barrel nut (C) as shown below. Tighten with allen wrench (G).
For Slat kit assembly, follow assembly instructions included with slat kit.

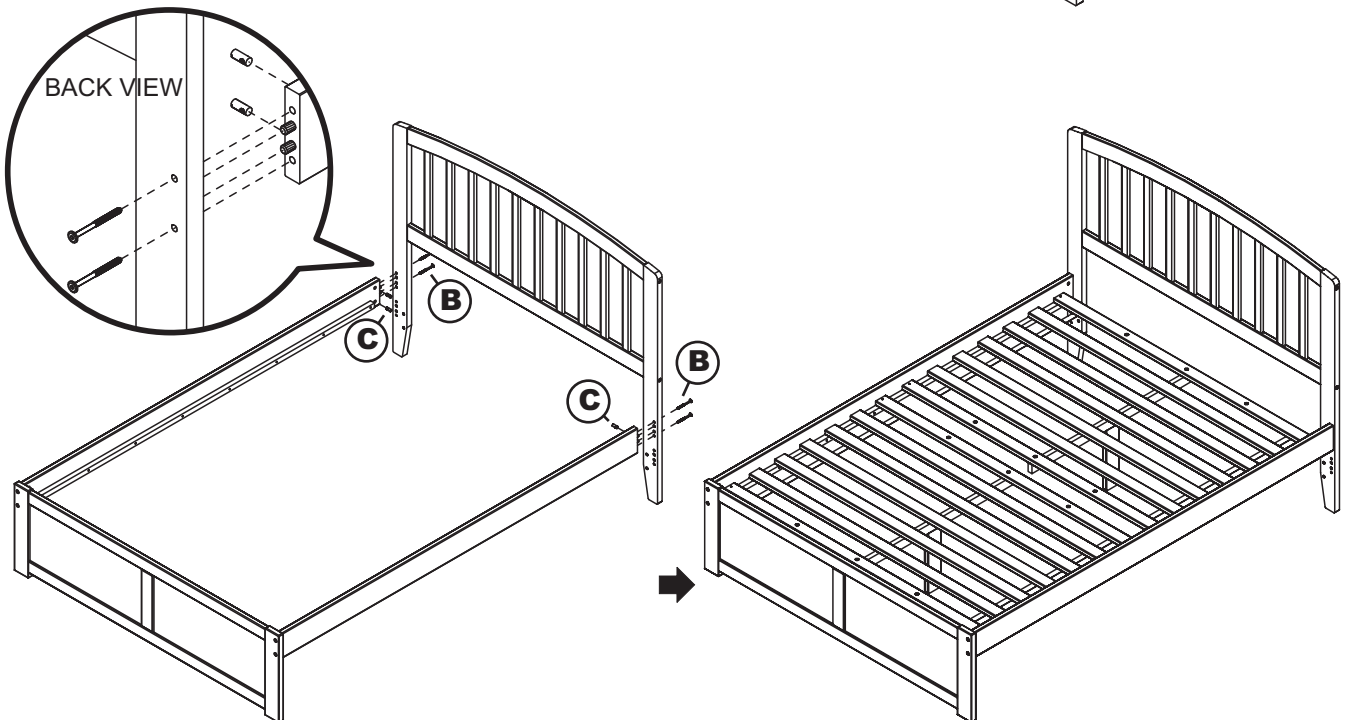



RICHMOND HEADBOARD

attach to metal frame sold separately

ATLANTIC
FURNITURE

ASSEMBLY INSTRUCTIONS

Before assembling your Bed, please read through these instructions carefully. Familiarize yourself with the different parts.

Instructions apply for all sizes of bed
Twin > Full > Queen > King



PARTS LIST

- 01 HARDWARE
- 02 HEADBOARD

Step 1 Attach the headboard assembly (02) to the metal frame (03) as shown below. Using JCB (F) and flat, split washer (E)(D) tighten with Allen wrench (G).

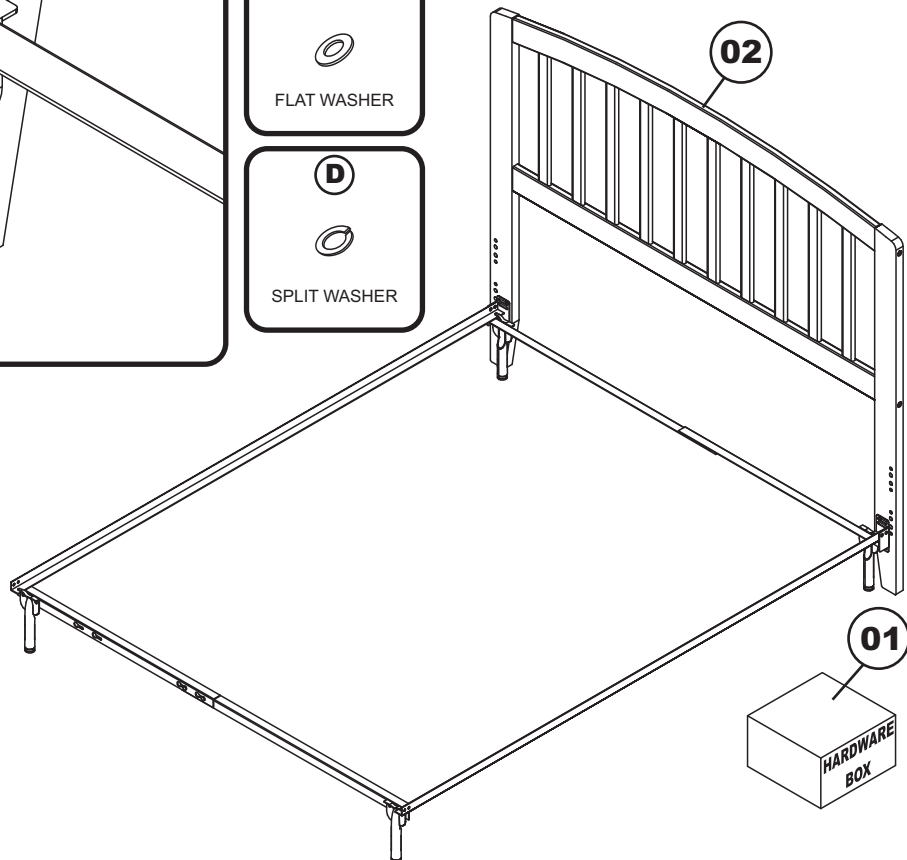
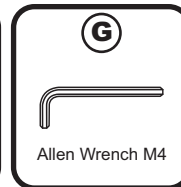
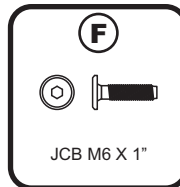
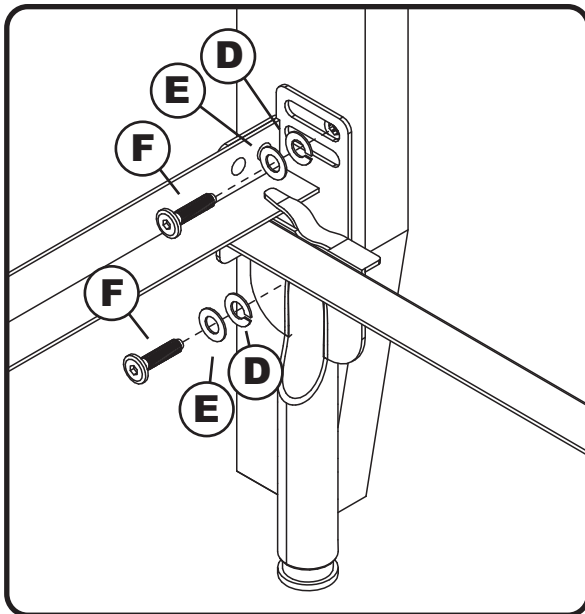

Congratulations!

Your Richmond Bed is now ready for use.
We recommend that you periodically check that all screws are tight
and all parts are secure to ensure lasting safety.