

Dear Our Valuable Customers,

Please follow our assembly instructions in every step,  
we guarantee that you will get the perfect merchandise.

Thank you so much for purchasing our quality products.



## PART LIST

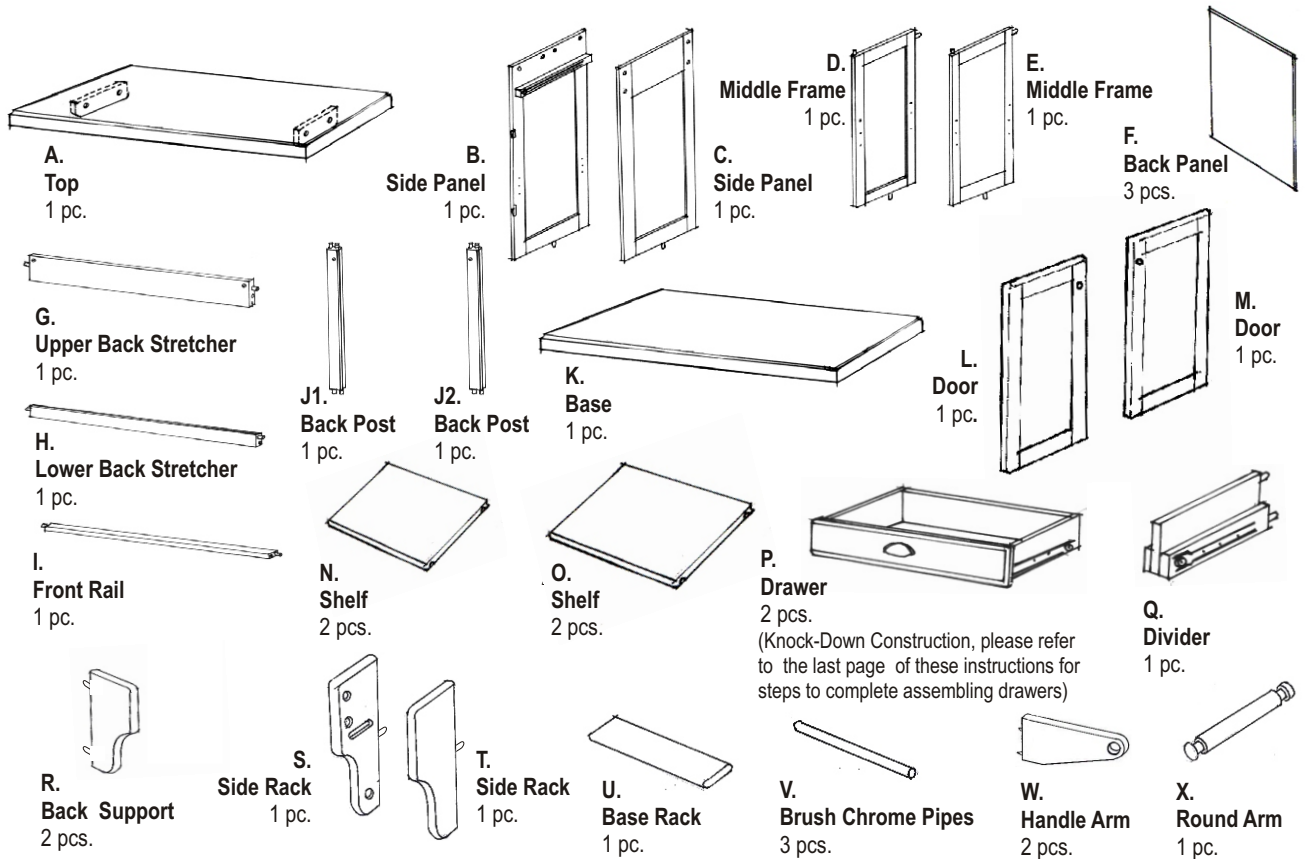

## HARDWARE LIST

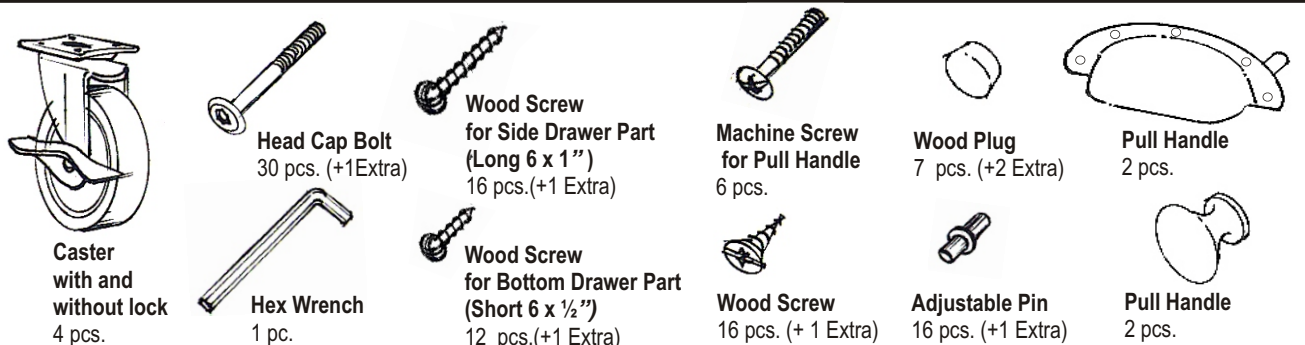

Tools Required For Assembly : Phillips screwdriver

# Assembly Instructions 2/5

## IMPORTANT NOTE

Do not tighten up all the screws until each part is properly assembled.  
You should keep Hex Wrench in the safe place as you may need to tighten up the Head Cap Bolts in the future.

## STEP 1

Attach the Lower Back Stretcher (H) to the Side Frame (B), using Head Cap Bolts.

Attach The Back Post (J1),(J2) to the Lower Back Stretcher (H) and slide the Back Panels (F) to place.

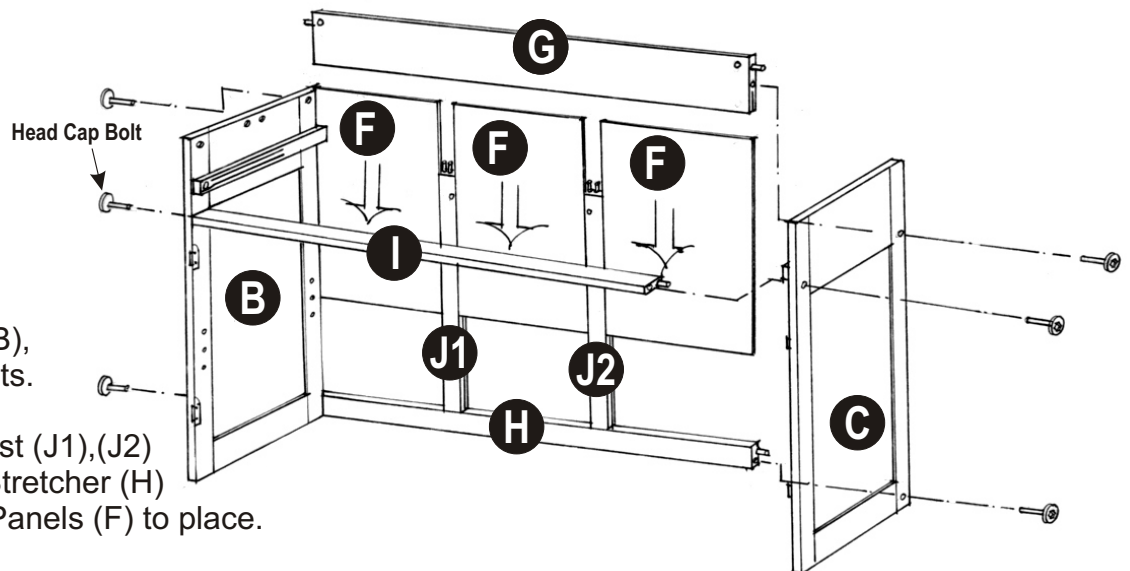

Attach the Upper Back Stretcher (G) to the assembled unit, using Head Cap Bolts.

Attach the Front Rail (I) to the Side Frame (B) with Head Cap Bolts.

Attach the Side Frame (C) to the assembled unit, tighten up all Head Cap Bolts.

## STEP 2

Turn the unit in Step1 upside down.  
Attach the Middle Frame (D) and (E) to the unit.

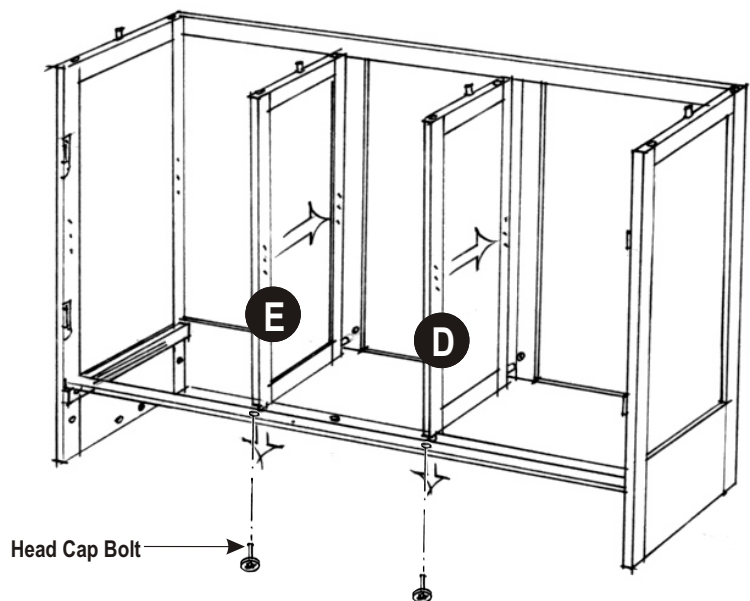

## STEP 3

Attach 4 Casters to the underside of the Base (K), put the 2 Casters with lock in front as you first need to keep the cart firmly in place. (See sticker in the bottom indicating front side)

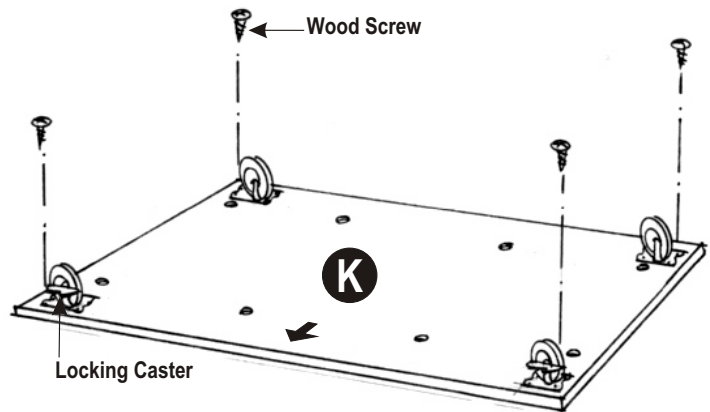
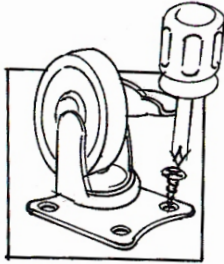

## STEP 4

Place the Base (K) on the unit.

Tighten up all Head Cap Bolts.

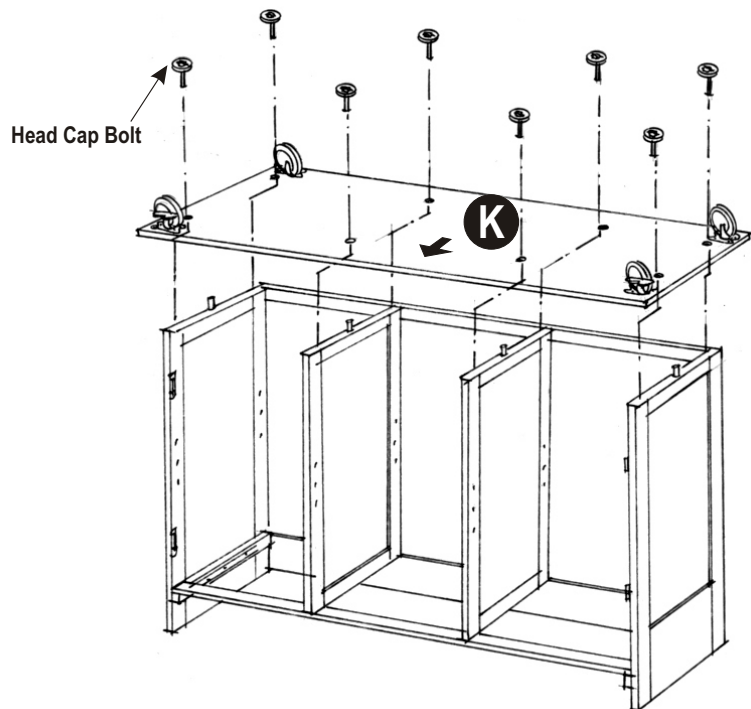

## STEP 5

Turn the assembled unit to back its normal position.

Attach the Divider (Q) in the middle.

Attach the Back Support (R) to the Upper Back Stretcher (G), using Head Cap Bolts.

Attach the Handle Arm (W) to the Side Panel (C) with Head Cap Bolts.

Slide the Round Arm (X) into place.

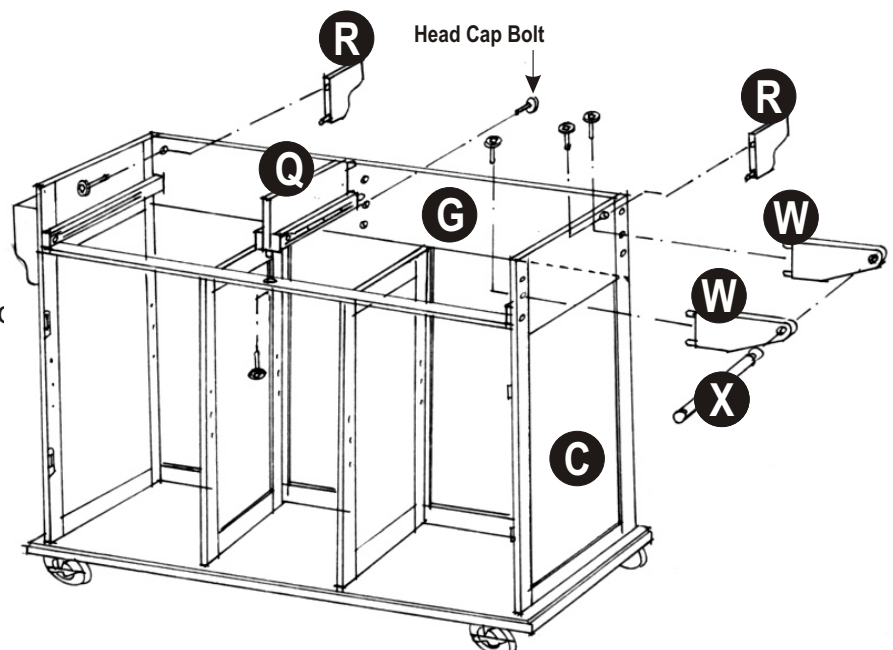

# Assembly Instructions 4/5

## STEP 6

Attach the Side Rack (S) to the Side Panel (B) with Head Cap Bolts.

Attach the Brush Chrome Pipes (V) and the Base Rack (U) to the pre-drilled holes of the Side Rack (S).

Attach the Side Rack (T) to the Side Panel (B).

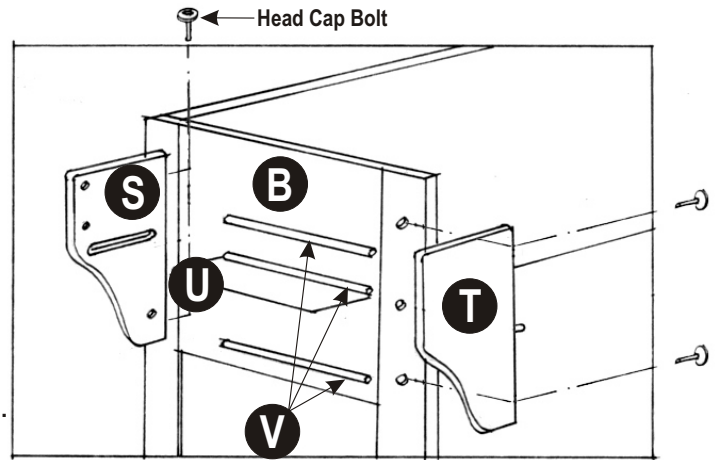

## STEP 7

Place the Top (A) on the unit.  
Tighten up the Head Cap Bolts.

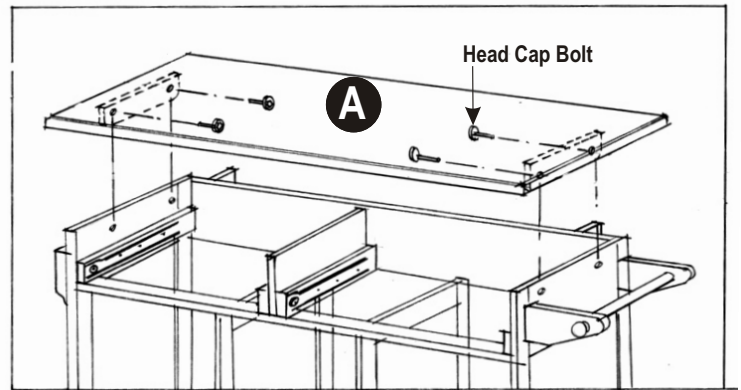

## STEP 8

Insert the Adjustable Pins into the Side Panels and into the Middle Frame at the desired level, then put the Shelf (N) into the place.

Attach the Pull Handles to the Door (L) and (M) with Machine Screws.

Attach the Door (L) and (M) to the Side Panel by sliding the door lift hinges into the side panel lift hinges.

See assembly instructions for Drawers in the last page.

Slide the Drawers (P) into place.

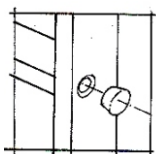
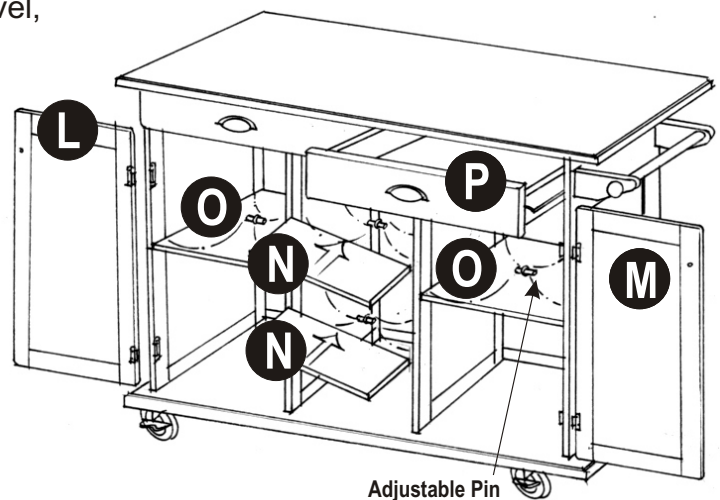

## STEP 9

Cover all holes with Wood Plugs.

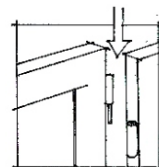

Lift hinge Assembly

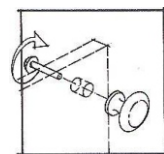

Pull Handle Assembly

## Drawer

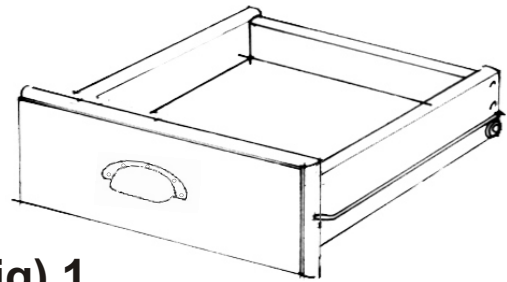

(Fig) 1

Line up Side Parts (O3) and (O4) to the Front Part (O1) and Back Part (O2). Be sure to follow the Arrow sign sticker on the parts. Using a *Phillips* screw driver, insert 1" screws into each of the 4 pre-drilled holes in sides (O3) and (O4), then tighten half way.

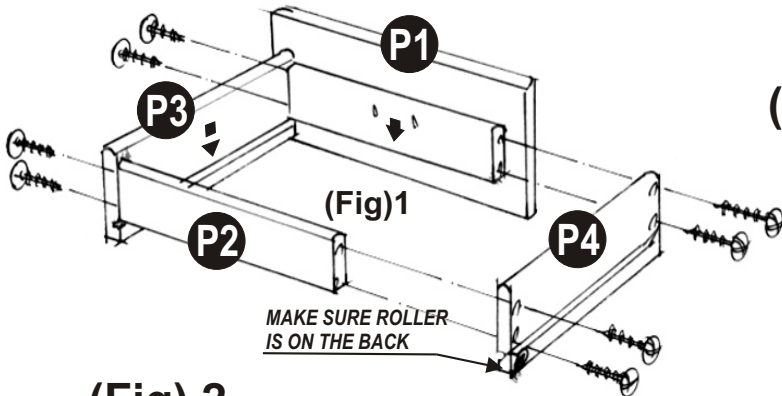

(Fig) 2

Turn the assembled drawer over and slide the Plywood Bottom Part (O5) into the grooves on Side Parts (O3) and (O4). Be sure to push the plywood all the way forward so it meets the Front Part (O1).

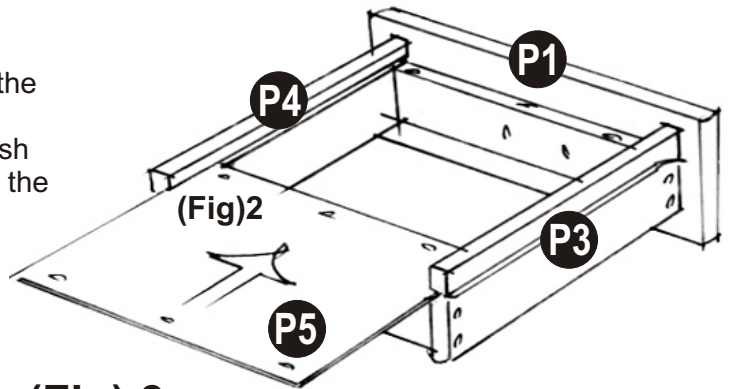

(Fig) 3

Insert the remaining (6) 1/2" screws into the pre-drilled holes in Bottom Part (O5), then tighten all screws

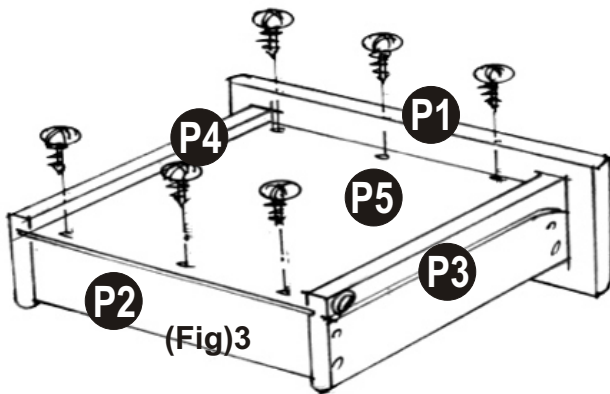

(Fig) 3

(Fig) 4

Assemble the Pull Handles with Machine Screws on the Front Part (O1).

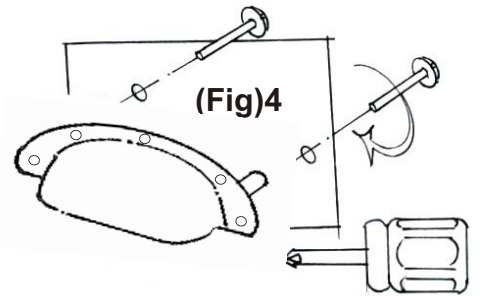

\* If you are missing any of these parts, please contact our DMI Customer Service Department at 1-877-831-0319 or fax us at 1-800-755-2878.

## Unit Part List

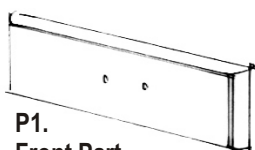

**P1.**  
Front Part  
2 pcs.

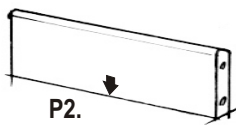

**P2.**  
Back Part  
2 pcs.

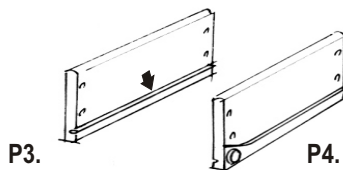

**P3.**  
Side Part  
2 pcs.



**P4.**  
Side Part  
2 pcs.

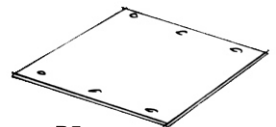

**P5.**  
Bottom Part  
2 pcs.