

ASSEMBLY INSTRUCTIONS

TWIN LOFT BED WITH CUSHION, DESK

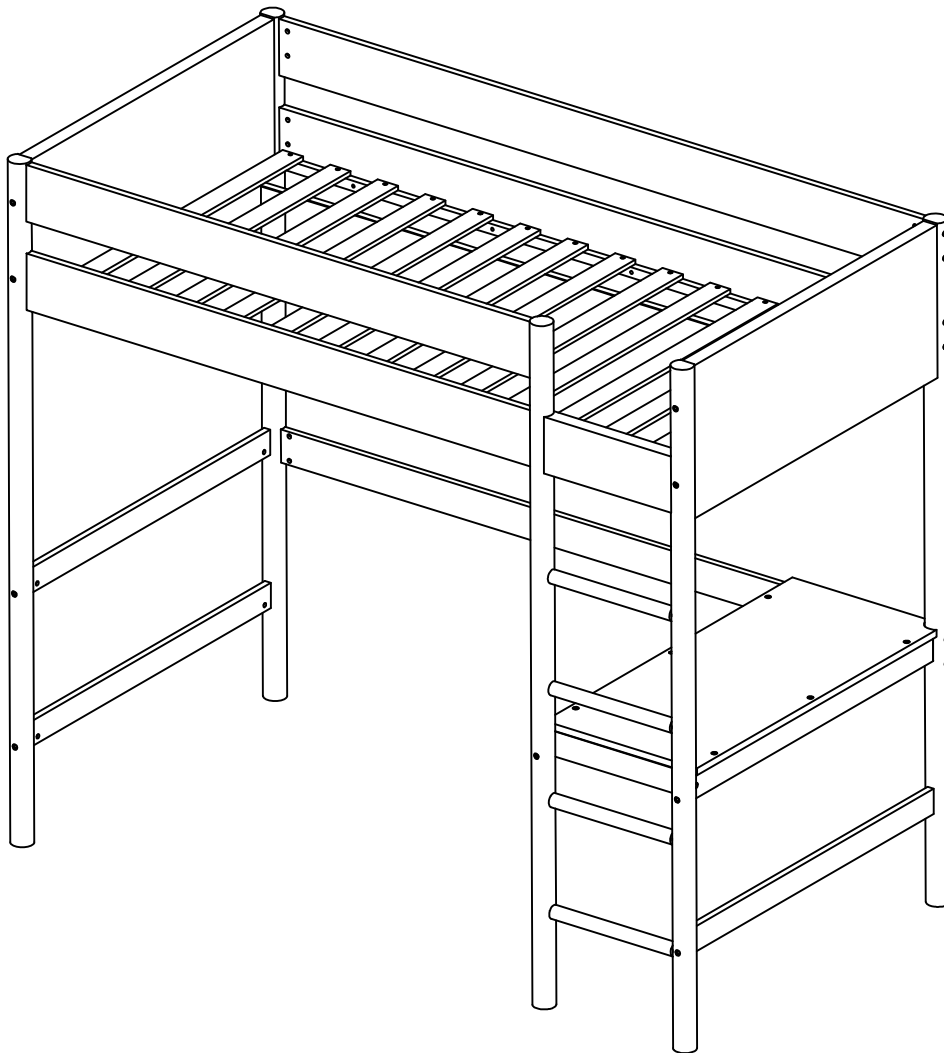



SAFETY WARNING



1. This bed is designed for use only mattress (es) meeting the following specifications on the upper bunk, and lower bunk:

Down bed

| Bed type | Length | With | Thickness |
|---------------|---------|---------|-----------|
| Twin Standard | 74"-75" | 38 1/2" | 6" max |

Up bed (Bunk bed and tribed included)

| Bed type | Length | With | Thickness |
|---------------|---------|---------|-----------|
| Twin Standard | 74"-75" | 38 1/2" | 6" max |

2. Replacement parts, including additional guardrails, maybe obtained from any of our dealers.
3. Follow the information on the warnings appearing on the upper bunk bed end structure and on the carton. Do not remove warning label from bed.
4. Always use the recommended size mattresses or mattress supports, or both, to help prevent the likelihood of entrapment or falls.
5. Surface of mattress must be at least 5" (127mm) below the upper edge of guardrails.
6. Do not allow children under 6 years of age to use the upper bunk.
7. Periodically check and ensure that the guardrail, ladder, and other components are in their proper position, free from damage, and that all connectors are tight.
8. Do not allow horseplay on or under the bed and prohibit jumping on the bed.
9. Always use the ladder for entering and leaving the upper bunk.
10. Do not use substitute part. Contact the manufacture or dealer for replacement part.
11. Use of a night light may provide added safety precaution for a child using the upper bunk.
12. Always use guardrails on both long sides of the upper bunk. If the bunk bed will be placed next to the wall, the guardrail that runs the full length of the bed should be placed against the wall to prevent entrapment between the bed and wall.
13. The use of water or sleep flotation mattresses is prohibited.
14. **STRANGULATION HAZARD** - Never attach or hang items to any part of the bunk bed that are not designed for use with the bed; for example, but not limited to, hook, belts and jump ropes.
15. Keep these instruction for future reference.

Detail View

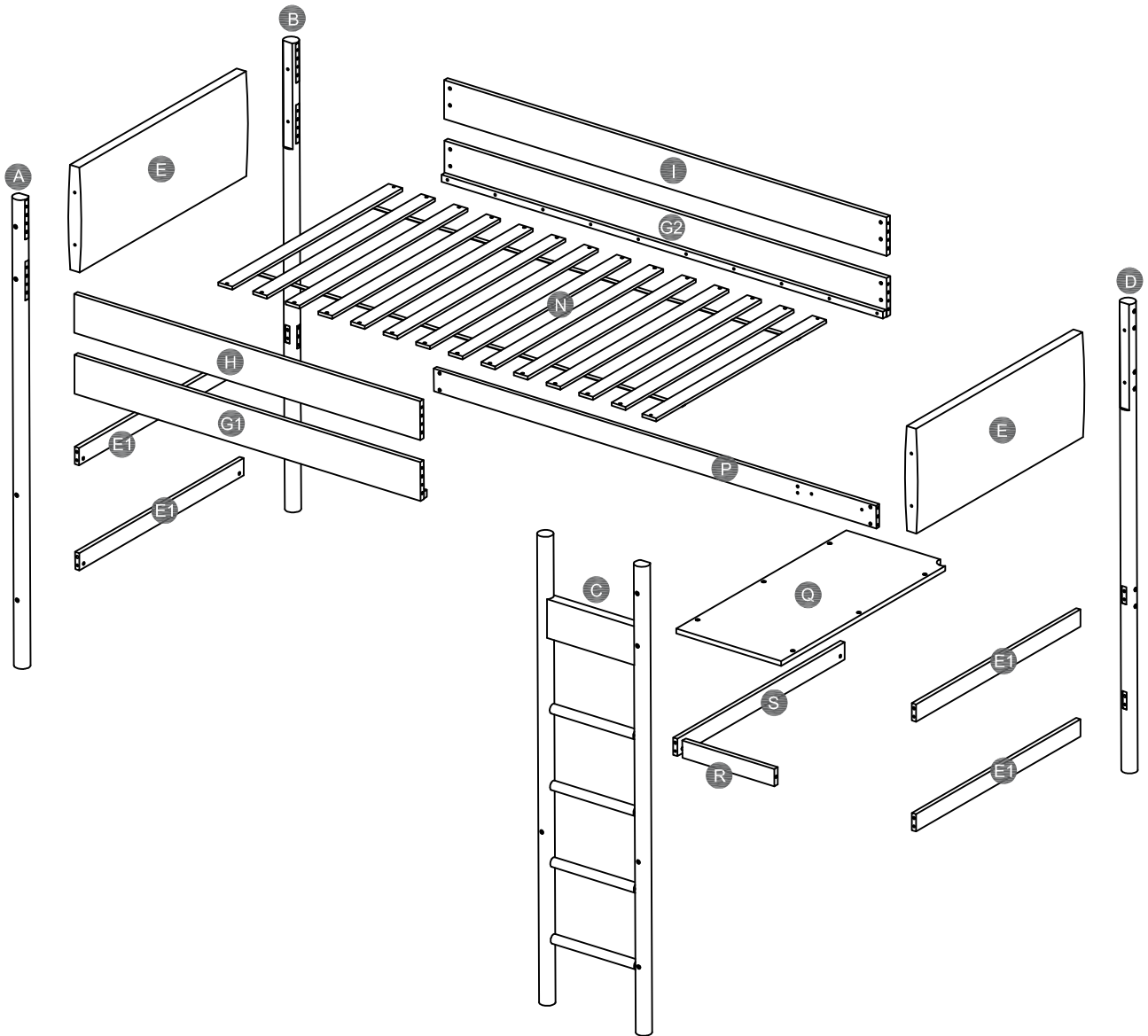

Part List

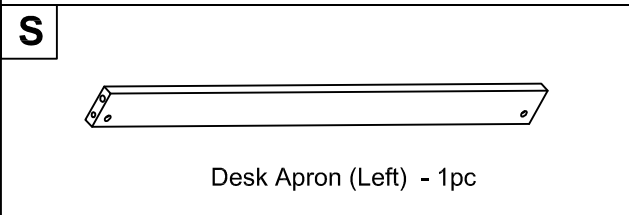
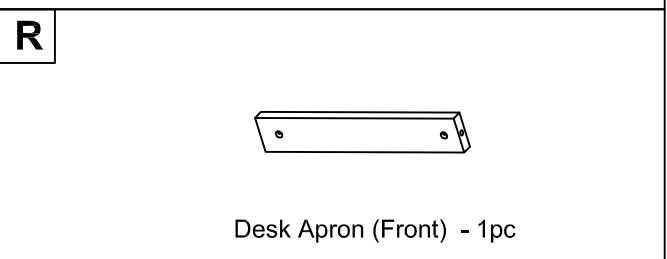
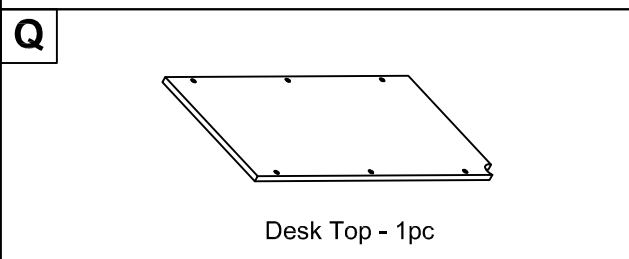
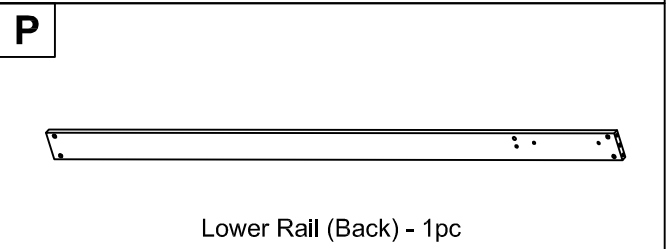
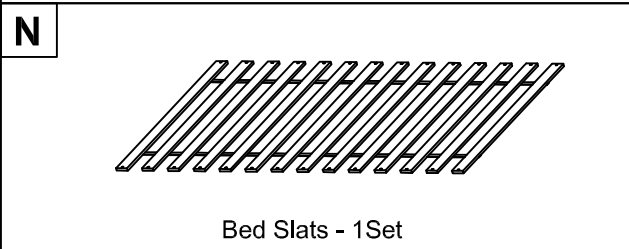
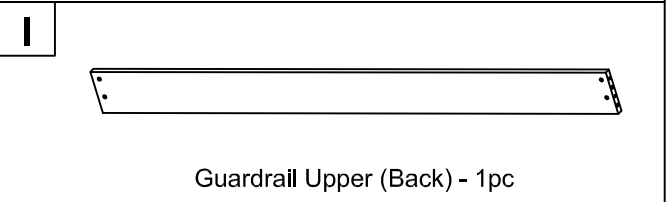
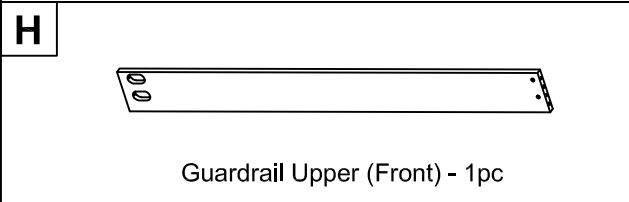
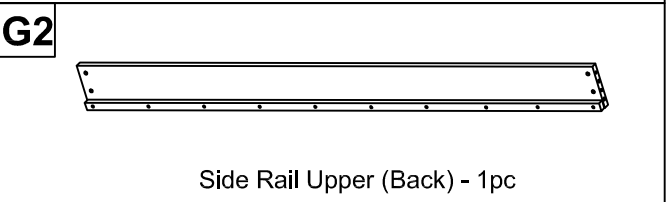
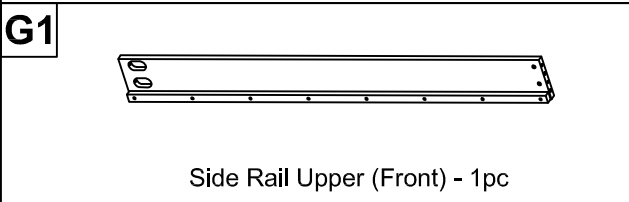
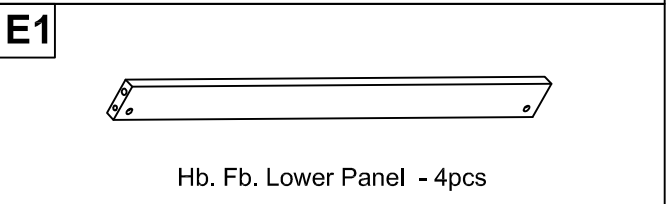
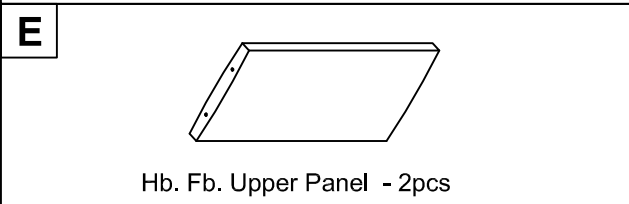
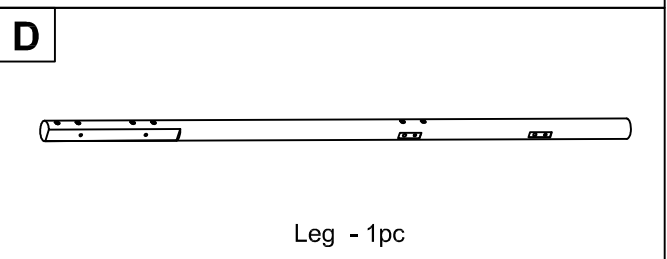
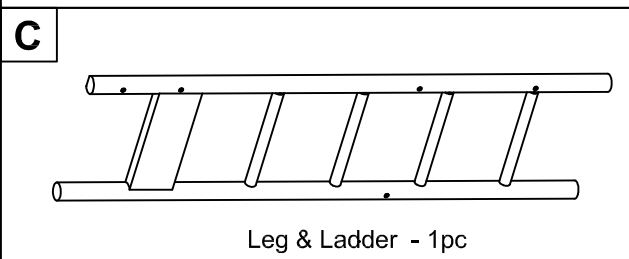
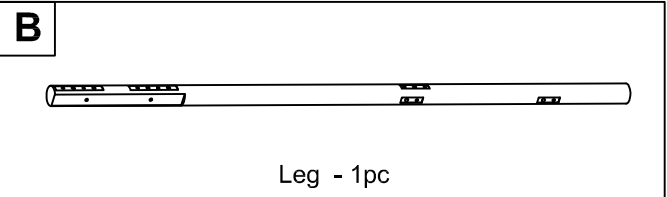
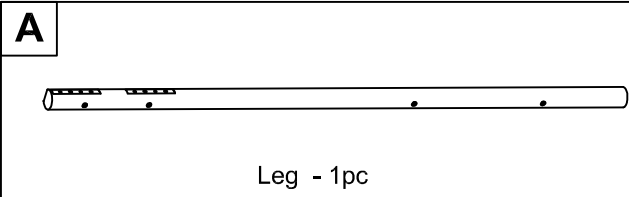

Hardware List

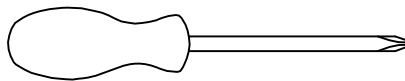

| | | |
|---|---|--|
| 1  M6 x 90mm JCBC (25pcs) | 2  M6 x 50mm JCBC-W (6pcs) | 3  M6 x 15mm Barrel Nut (28pcs) |
| 4  M10 x 30mm Wood Dowel (28pcs) | 5  M8 x 80mm JCBB (8pcs) | 6  M4 x 25mm CSK Screw (24pcs) |
| 7  M6 x 60mm JCBC (7pcs) | 8  M6 x 30mm JCBC-W (4pcs) | 9  M6 Half Moon Nut (4pcs) |
| 10  Flat Washer (4pcs) | 11  Split Lock Washer (4pcs) | 12  Sticker Cap (6pcs) |
| 13  M4 Allen Key (1pc) | 14  M5 Allen Key (1pc) | |

ASSEMBLY TOOLS REQUIRED (NOT INCLUDED)



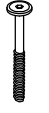

PLEASE BE CAREFUL DO NOT DAMAGE THE HOLE POSITION WHEN YOU USE POWER TOOLS !

STEP 1:

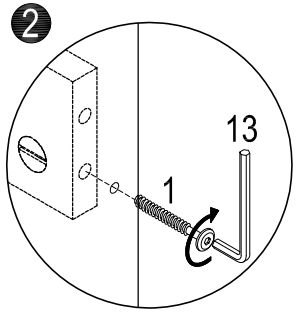
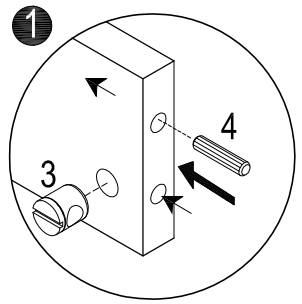
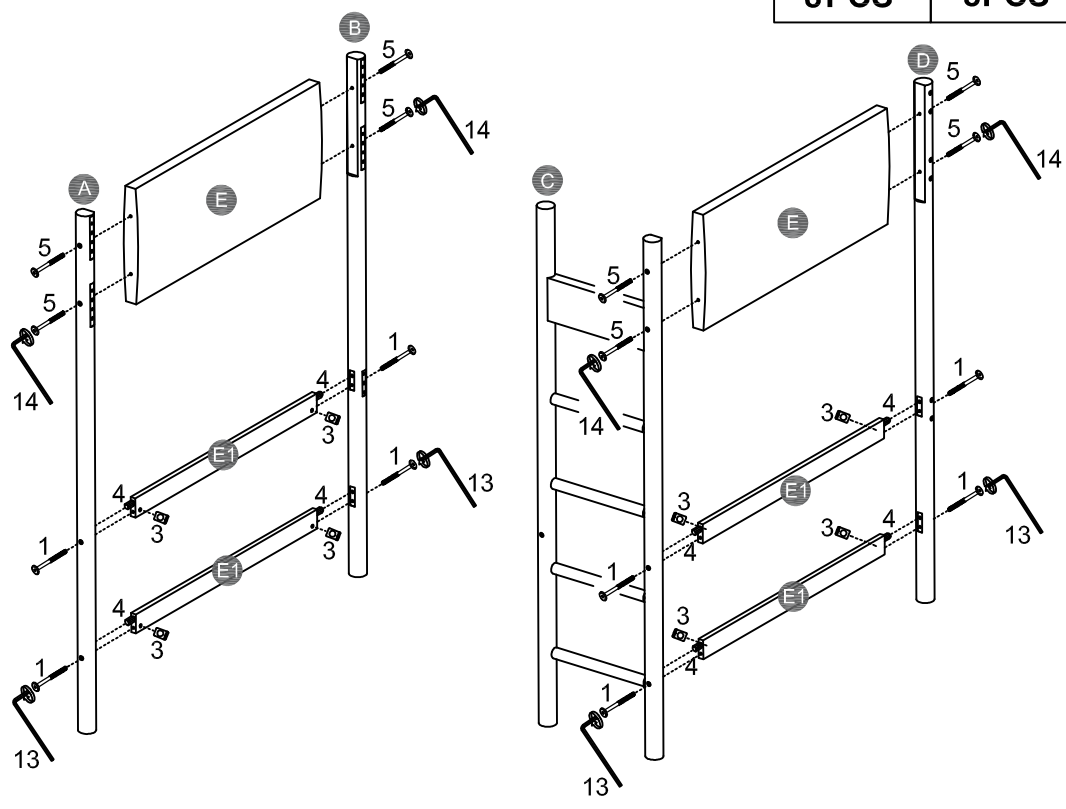
| | | | | | | | |
|-------------|---|-------------|---|-------------|---|-------------|---|
| 1 |  | 3 |  | 4 |  | 5 |  |
| 8PCS | | 8PCS | | 8PCS | | 8PCS | |



STEP 2:

| | | | |
|------------|---|------------|---|
| 3 |  | 7 |  |
| 1PC | | 1PC | |

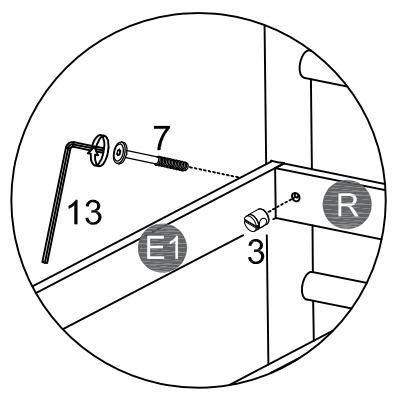
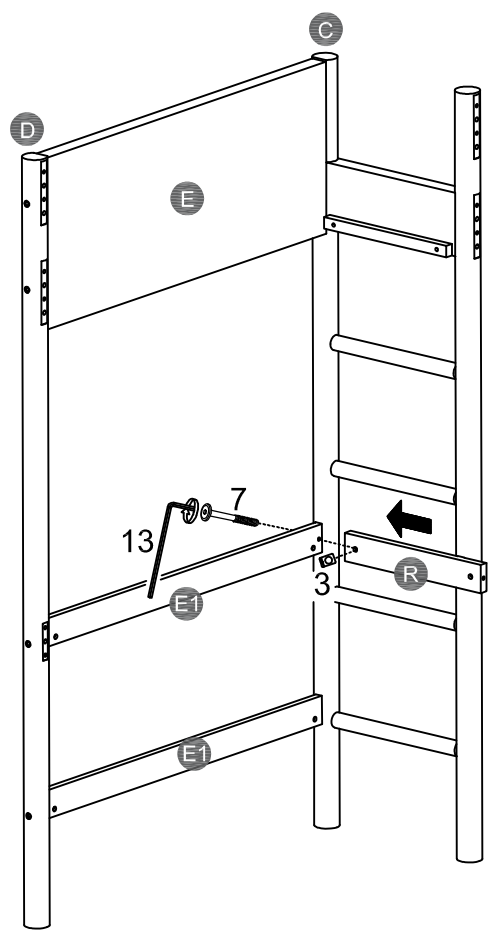

STEP 3:

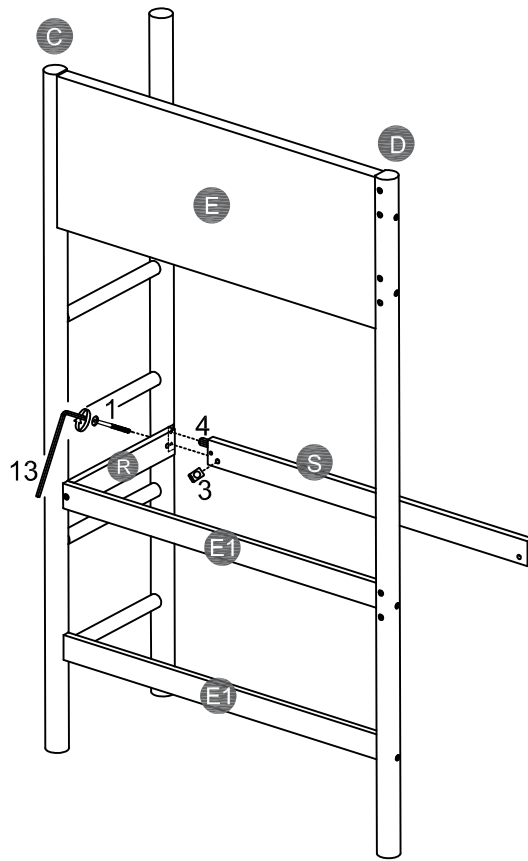

| | | | | | |
|----------|-----|----------|-----|----------|-----|
| 1 | | 3 | | 4 | |
| | 1PC | | 1PC | | 1PC |

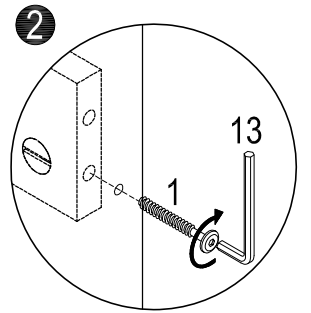
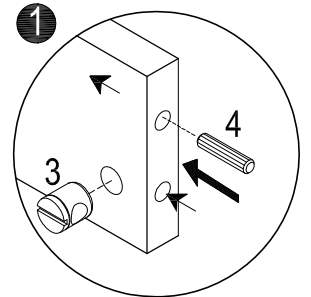



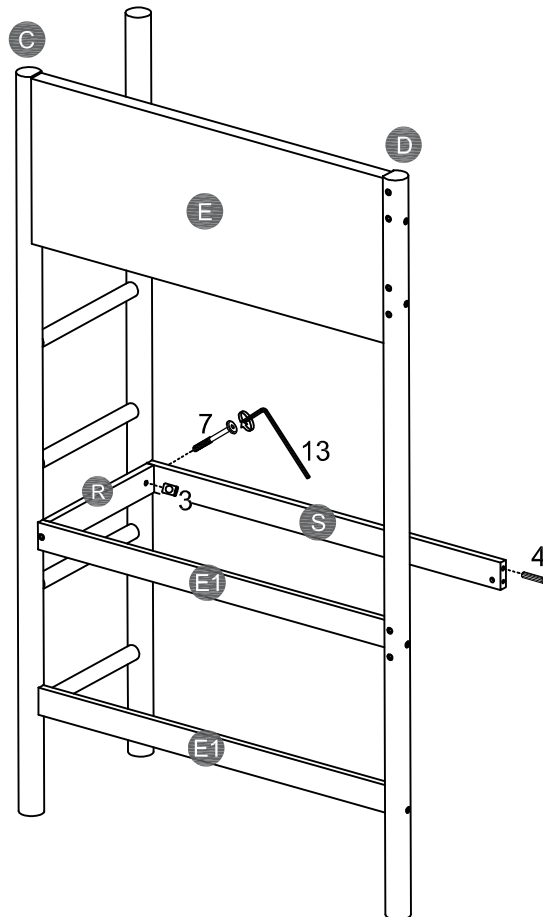

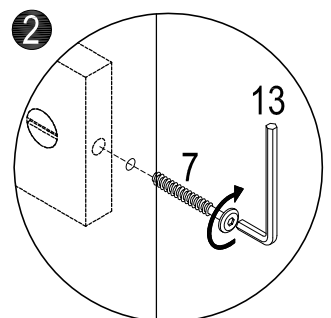
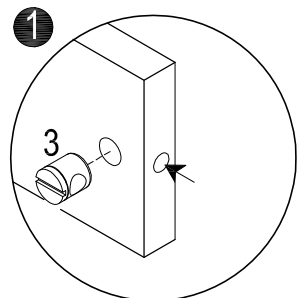

STEP 4:



| | | | | | |
|----------|-----|----------|-----|----------|-----|
| 3 | | 4 | | 7 | |
| | 1PC | | 1PC | | 1PC |



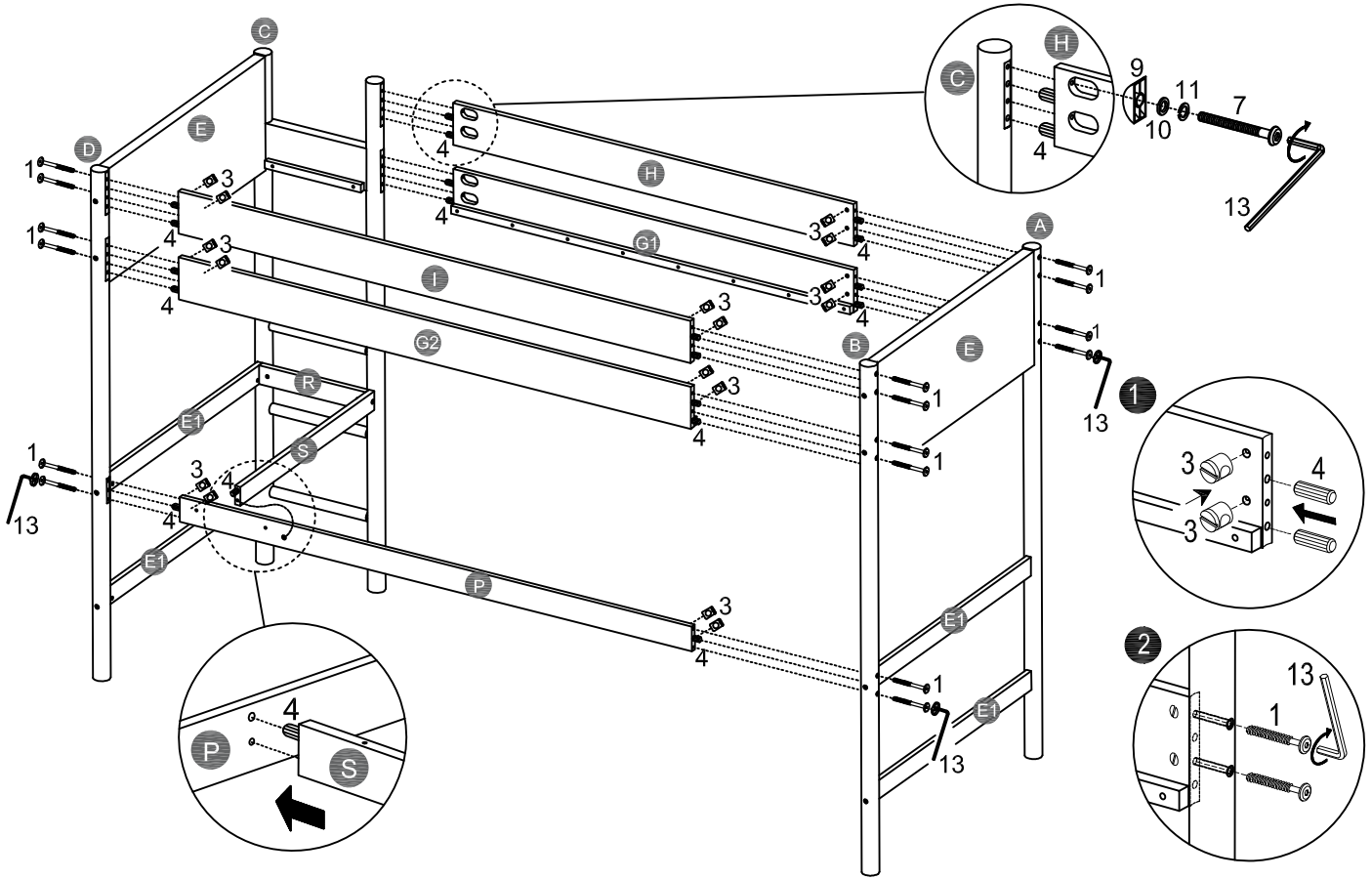

STEP 5:

| | | | | | | | | | | | | | |
|--------------|---|--------------|---|--------------|---|-------------|---|-------------|---|-------------|---|-------------|---|
| 1 |  | 3 |  | 4 |  | 7 |  | 9 |  | 10 |  | 11 |  |
| 16PCS | | 16PCS | | 18PCS | | 4PCS | | 4PCS | | 4PCS | | 4PCS | |



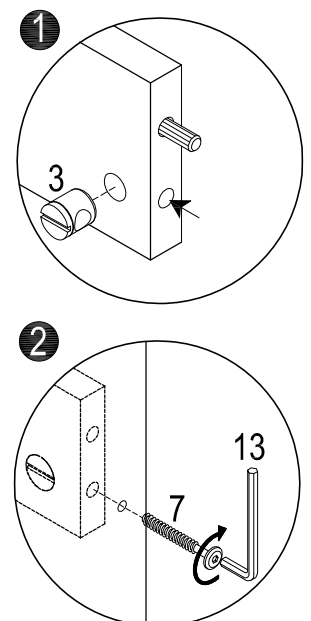
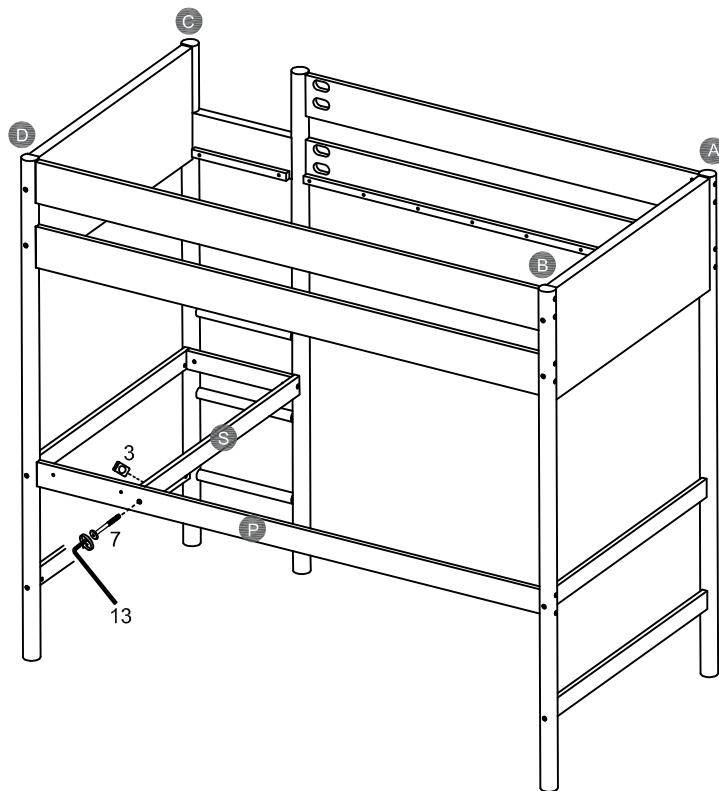

STEP 6:

| | | | |
|------------|---|------------|---|
| 3 |  | 7 |  |
| 1PC | | 1PC | |



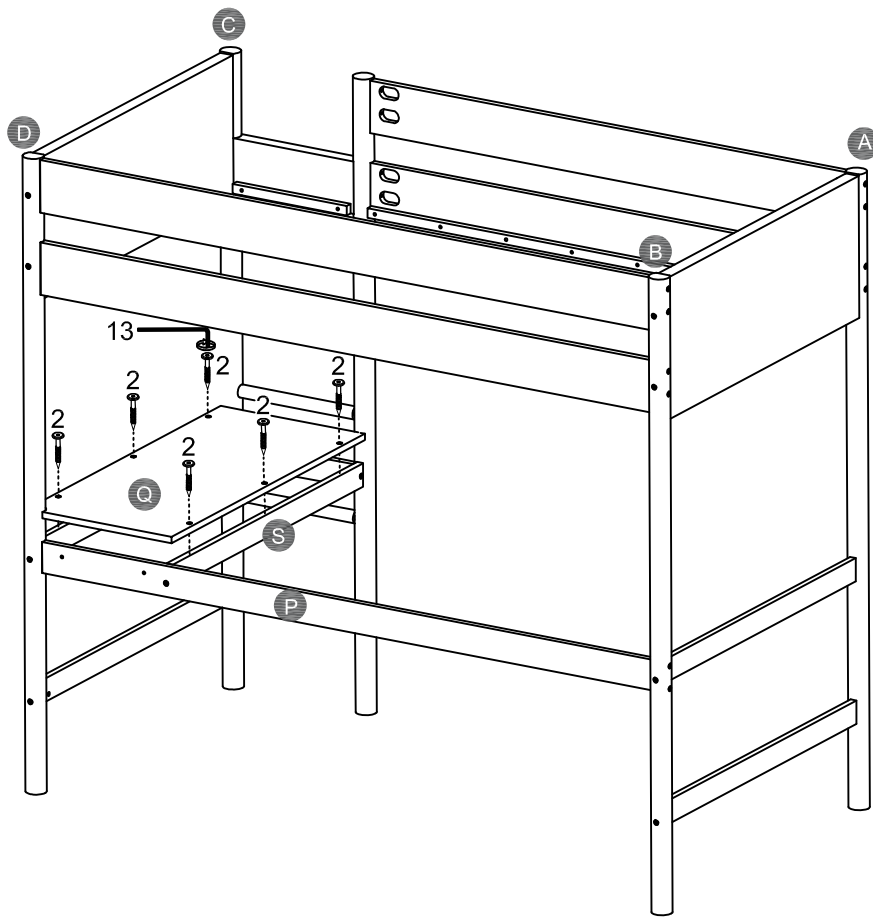

STEP 7:



| | |
|-------------|---|
| 2 |  |
| 6PCS | |

STEP 8:

| | | | | | |
|--------------|---|-------------|---|-------------|---|
| 6 |  | 8 |  | 12 |  |
| 24PCS | | 4PCS | | 6PCS | |

