

This instruction manual contains important information. Follow the consecutive order. Please read and keep for future reference.

Este Manual contiene información importante. Siga el orden consecutivo de las instrucciones.

Por favor léalo y guárdelo para consultas en el futuro.



Two or more people are required assemble and move this unit.
Se requiere de dos o más personas para armar y mover este mueble.



Unpack and assemble this unit in an spacious area. Assemble the unit on top of the empty box to prevent scratches.
Desempaque y arme este mueble en un area espaciosa. Arme el mueble sobre su caja, para no rayarlo.



Protect furniture from water and moisture. This furniture must not be used outdoors.
Proteja el mueble del agua y de la humedad. No use este mueble al aire libre.



Do not expose it to heat.
No lo exponga al calor.



Do not hit or tap with a hammer, unless it is indicated.
No lo golpee ni lo martille.



Do not paint or use abrasive elements to clean this furniture.
No pinte ni use elementos abrasivos para limpiar este mueble.



Do not drag or climb on your furniture. If you need to move it, lift it.
No lo arrastre ni se suba al mueble. Si necesita moverlo, levántelo.

PARTS IDENTIFICATION / IDENTIFICACIÓN DE PARTES

EXPLODED VIEW/DESPIECE

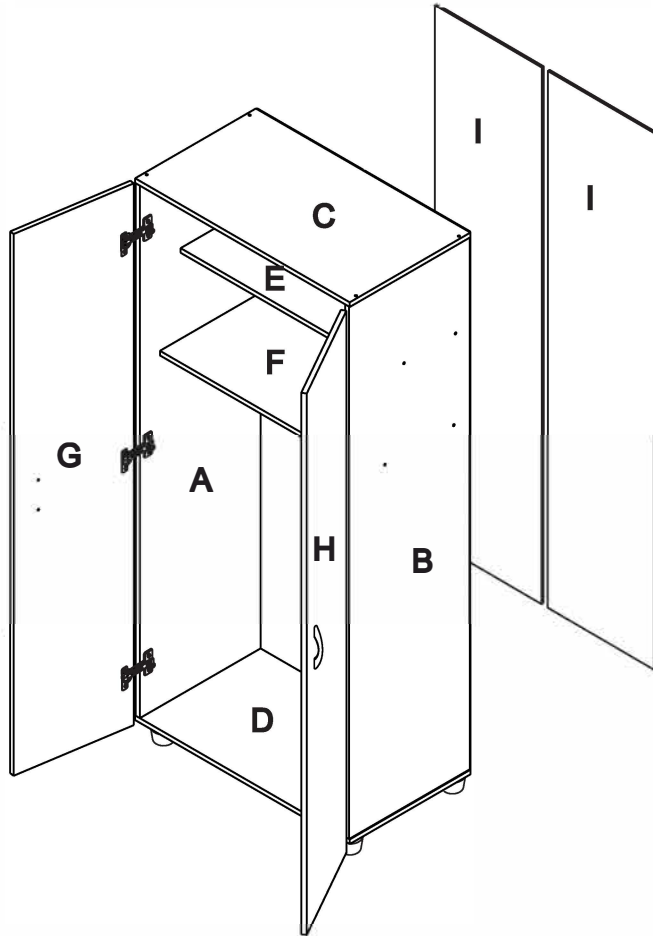

PARTS LIST TABLA DE PIEZAS

PARTS PIEZA	QUANTITY CANTIDAD
A	1
B	1
C	1
D	1
E	1
F	1
G	1
H	1
I	2

QUANTITY CANTIDAD	FROM DESDE	TO HASTA
10	A	I

IDENTIFICACIÓN DE HERRAJES HARDWARE IDENTIFICATION

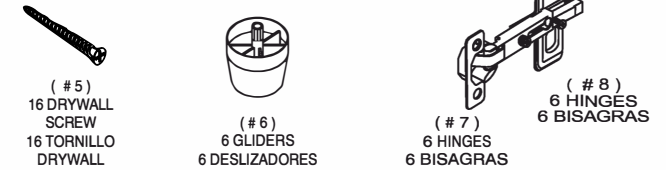
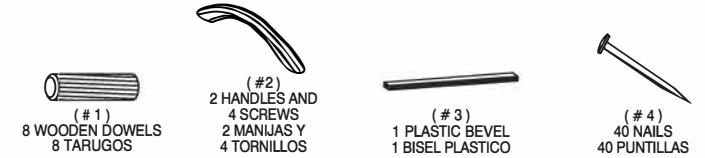

ASSEMBLY STEPS / PASOS PARA ENSAMBLAR 1

FURNITURE ASSEMBLY ARMADO DEL MUEBLE

PARTS SET UP / PREPARACIÓN DE PIEZAS

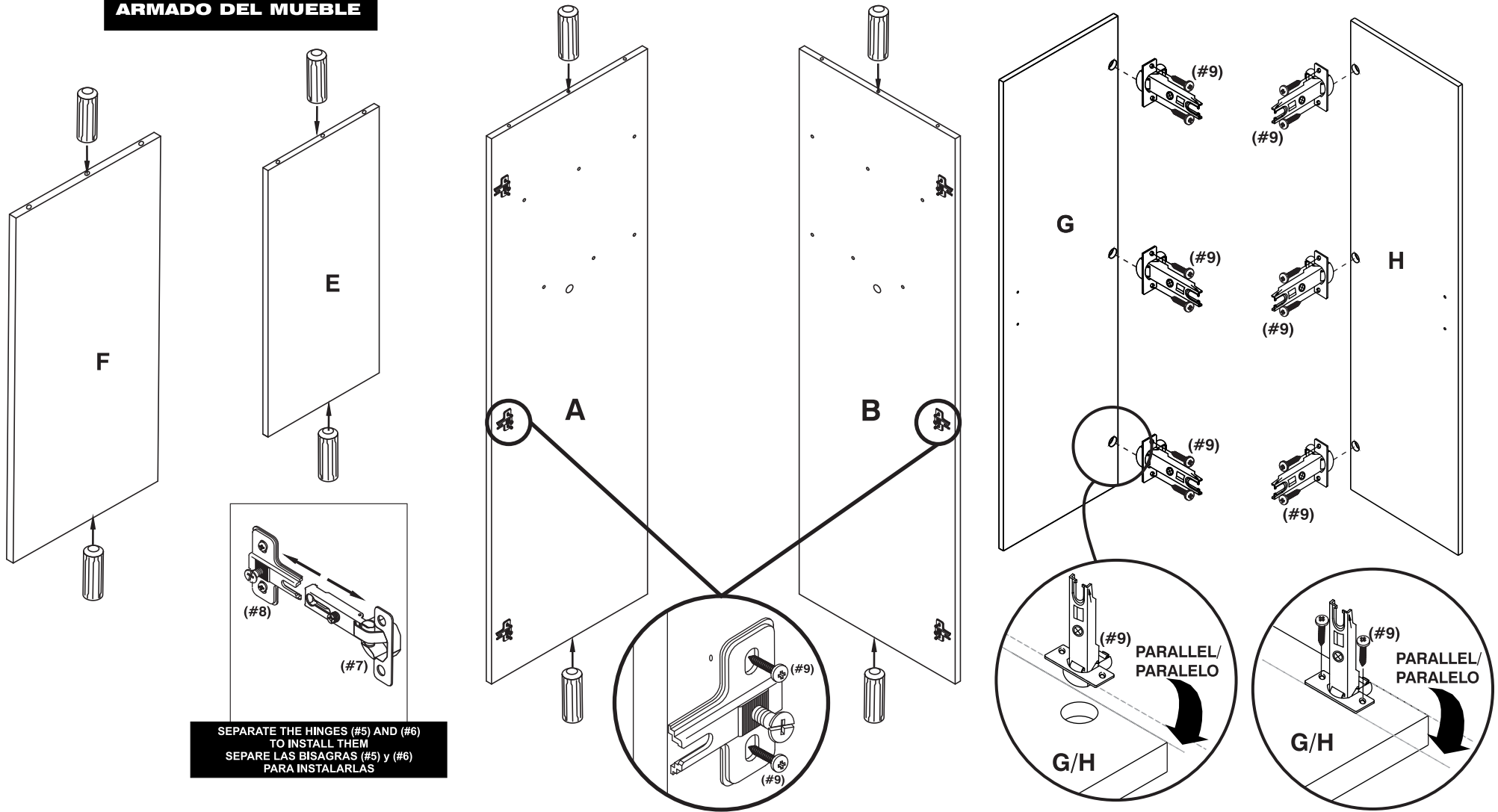

SEPARATE THE HINGES (#5) AND (#6)
TO INSTALL THEM
SEPARA LAS BISAGRAS (#5) y (#6)
PARA INSTALARLAS

FOR THIS STEP, YOU WILL NEED:
EN ESTE PASO NECESITA:

TOOLS
HERRAMIENTAS

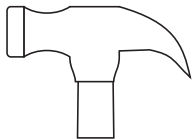

MARTILLO
/HAMMER



PHILLIPS SCREWDRIVER /
ATORNILLADOR DE ESTRELLA

HARDWARE
HERRAJES

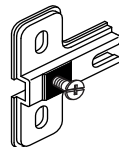

HINGES
BISAGRAS
(# 8)

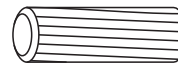

(# 1)
WOODEN PINS
TARUGOS



(# 9)
CATCH SCREWS
TORNILLO
BISAGRA

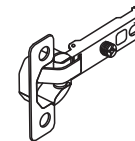

HINGES
BISAGRAS
(# 7)

2 ASSEMBLY STEPS / PASOS PARA ENSAMBLAR

PARTS SET UP / PREPARACIÓN DE PIEZAS

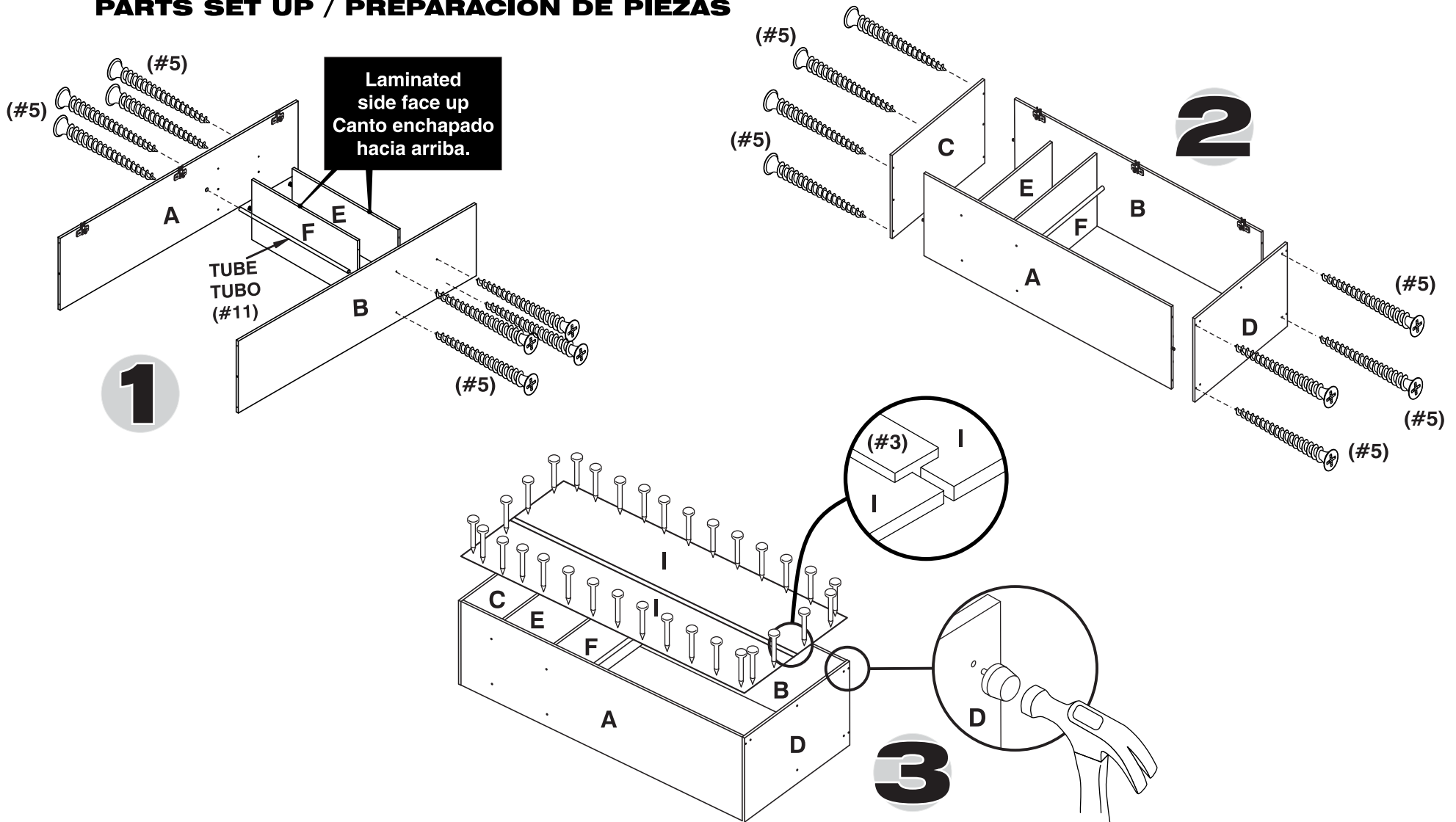

FOR THIS STEP, YOU WILL NEED:
EN ESTE PASO NECESITA:

TOOLS
HERRAMIENTAS

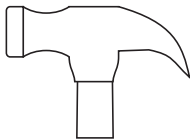

MARTILLO
/HAMMER



PHILLIPS SCREWDRIVER /
ATORNILLADOR DE ESTRELLA

HARDWARE
HERRAJES

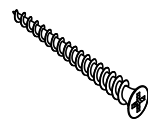

(# 5)
DRYWALL
SCREW
TORNILLO
DRYWALL

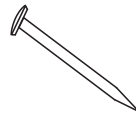

NAILS
PUNTILLAS
(# 4)

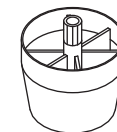

GLIDERS
DESLIZADORES
(# 6)



(# 3)
PLASTIC BEVELS
BISEL PLASTICO

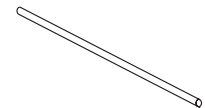

(# 11)
TUBE
TUBO
COLGADERO

ASSEMBLY STEPS / PASOS PARA ENSAMBLAR 3

PARTS SET UP / PREPARACIÓN DE PIEZAS

!To level the Door Parts "G/H", follow these steps:

!HEIGHT ADJUSTMENT: Allows parts "G/H" to be raised or lowered to level it with parts "A". Loosen the Hinge screw, as shown in the detail, to adjust the door to the desired position, and retighten the Hinge screws.

!DEPTH ADJUSTMENT: Allows parts "G/H" to be moved forward or backward by loosening the Hinge screw as shown in the detail.

!LATERAL ADJUSTMENT: Allows parts "G/H" to be moved right or left, leveling it with parts "A" by loosening or tightening the Hinge screw as shown in the detail.

!Para nivelar la puerta partes G/H, tenga en cuenta las siguientes indicaciones:

AJUSTE DE ALTURA: Le permite subir o bajar la partes G/H, cuadrándola al nivel de la parte A, aflojando el tornillo de la bisagra, como lo muestra el detalle.

Cuando este en el lugar indicado, asegure los tornillos bisagra. **AJUSTE DE PROFUNDIDAD:** Le permite llevar la partes G/H, hacia adentro o hacia afuera,

aflojando el tornillo de la bisagra, como lo muestra el detalle. **AJUSTE LATERAL:** Le permite llevar la partes G/H, hacia la derecha o la izquierda,

nivelándola con la parte A aflojando o apretando el tornillo de la bisagra, como lo muestra el detalle.

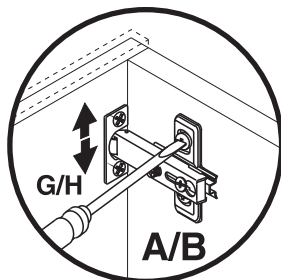

HEIGHT ADJUSTMENT

AJUSTE
ALTURA

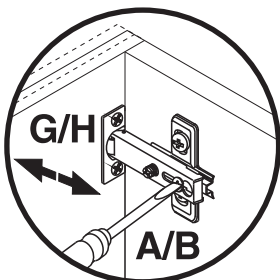

DEPTH ADJUSTMENT

AJUSTE DE
PROFUNDIDAD

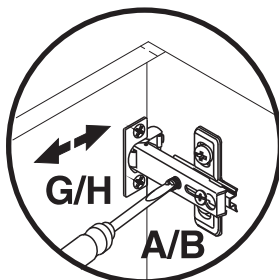

LATERAL ADJUSTMENT

AJUSTE
LATERAL

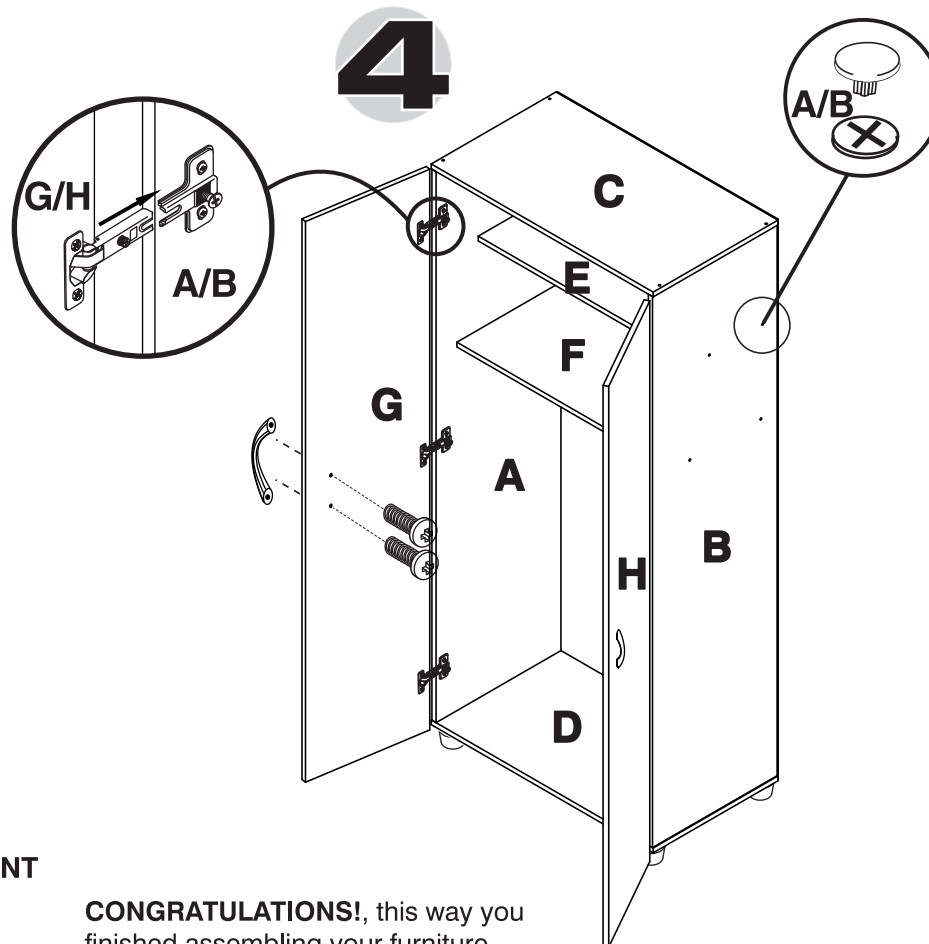

CONGRATULATIONS!, this way you finished assembling your furniture.

¡FELICITACIONES!, de esta manera usted termina de armar su mueble.

FOR THIS STEP, YOU WILL NEED:
EN ESTE PASO NECESITA:

TOOLS
HERRAMIENTAS

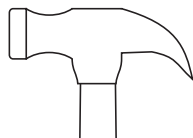

MARTILLO
/HAMMER



PHILLIPS SCREWDRIVER /
ATORNILLADOR DE ESTRELLA

HARDWARE
HERRAJES

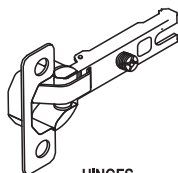

HINGES
BISAGRAS
(# 7)

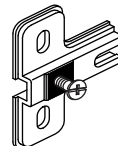

HINGES
BISAGRAS
(# 8)



CAPS SCREWS
TAPAS TORNILLO
DE ENSAMBLE
DRYWALL
(# 10)



(#2)
HANDLES
MANIJAS