

OFFICE CHAIR

Instruction Manual

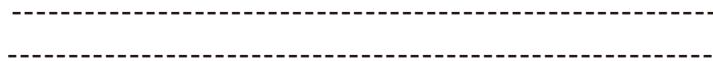

English
Español



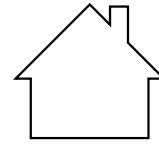

Home Office Use

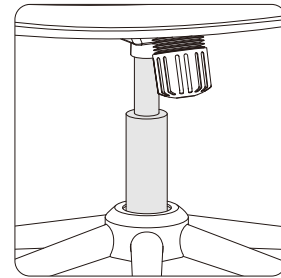
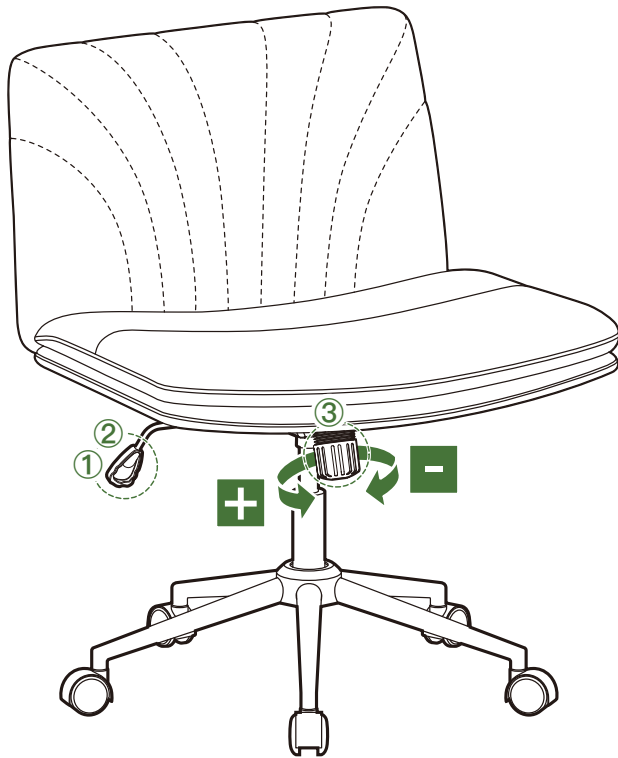

WARNING! Only trained personnel may replace or repair seat height adjustment components with energy accumulators.

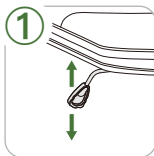

① Seat Height Adjustment:

To raise the seat, lift your body off the chair, then pull the lever up. To lower the seat, rest your body in the chair, then pull the lever up.

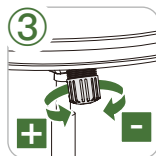
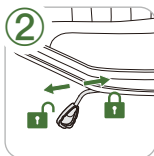

② Backrest Rocking Function:

Pull the lever out to enable the rocking function. The chair will rock back and forth with the user rather than being locked in a fixed position. Return the lever to its original position to lock it.

③ Backrest Tilt Tension Adjustment:

Turn the knob [+] or [-] to increase or decrease the rocking tension.

Tip: Tension can be adjusted to suit a particular weight. Increase tension for heavier weight and decrease tension for lighter weight.

Step 1 Supplied Parts and Hardware

01 x 1

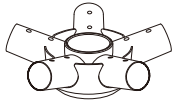

Leg Connector with
Decorative Cover

02 x 5



Leg

A x 10

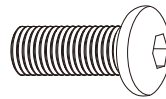

M6 x 14mm
Bolt

D x 1

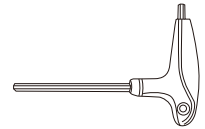

Allen Key

Step 2 Supplied Parts and Hardware

03 x 5

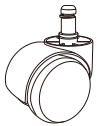

Caster

Step 3 Supplied Parts and Hardware

04 x 1



Gas Lift Cylinder

Step 4 Supplied Parts and Hardware

05 x 1



Seat

06 x 1

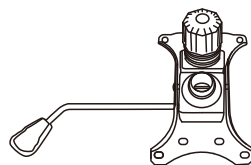

Lift Mechanism

B x 4



M6 x 18mm
Bolt

D x 1

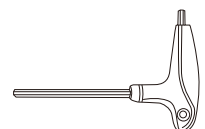

Allen Key

Step 5 Supplied Parts and Hardware

07 x 1

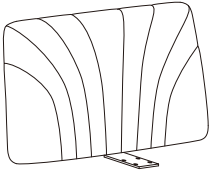

Backrest

C x 4

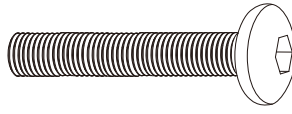

M6 x 30mm Bolt

D x 1

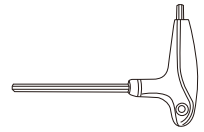

Allen Key

Support



We provide gloves that can be worn during installation.

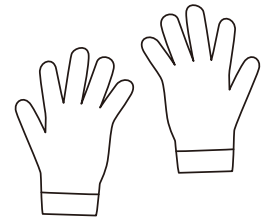

Step 1 Assembling the Chair Legs

Insert the legs [02] into the leg connector [01a], then secure with bolts [A].

Remove decorative cover and keep for Step 3.

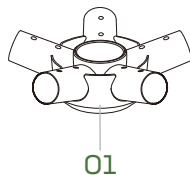

01

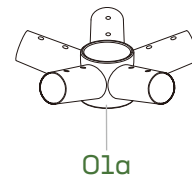

01a

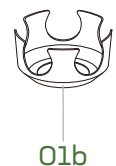

01b

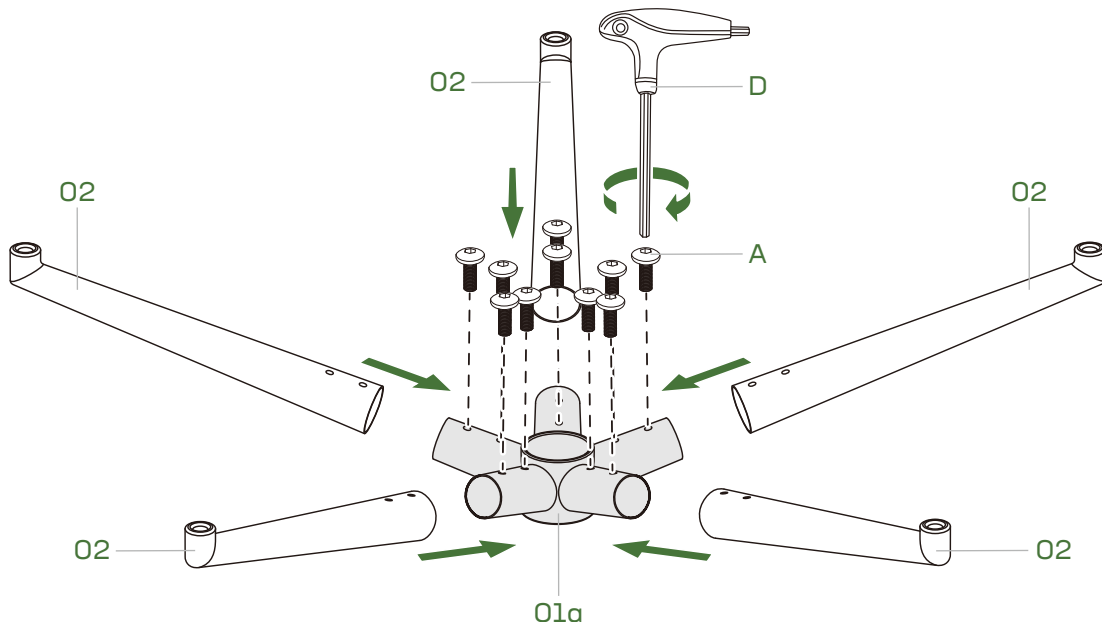

Step 2 Assembling the Casters

Press the casters [03] firmly into the holes on the legs [02].

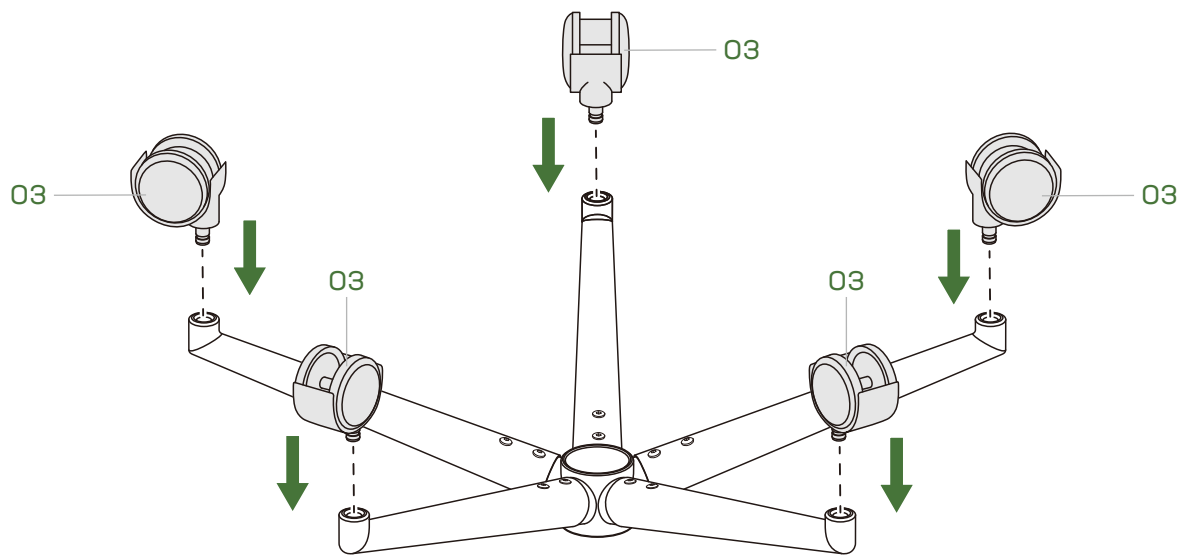

Step 3 Assembling the Chair Base

Flip over the assembled base. Attach the decorative cover [01b], then press the gas lift cylinder [04] into the leg connector.

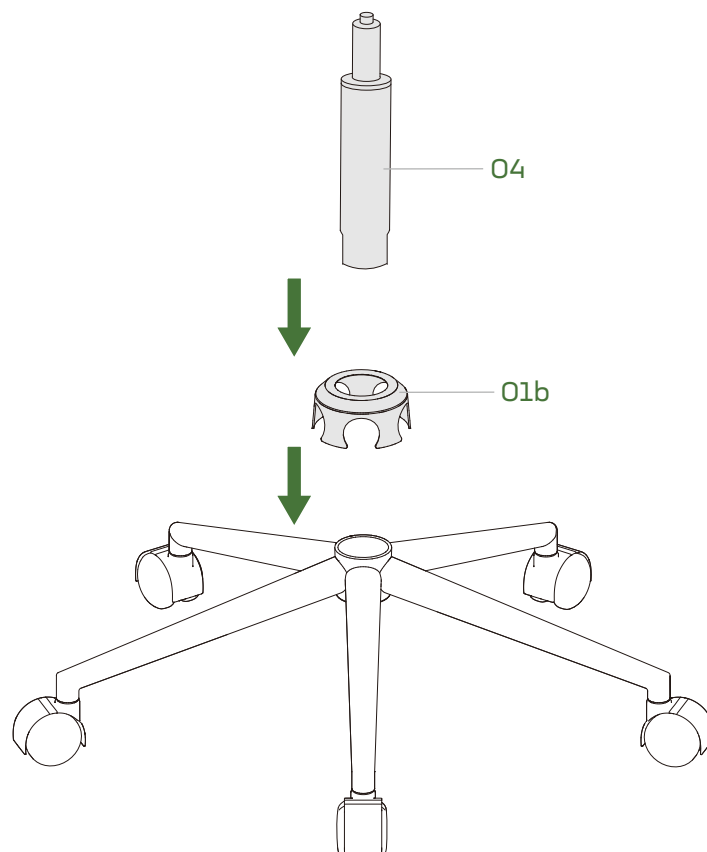

Step 4 Attaching the Lift Mechanism

Attach the lift mechanism [06] to the seat [05] using bolts [B].
NOTE: Do not overtighten bolts [B] until Step 5 is finished.

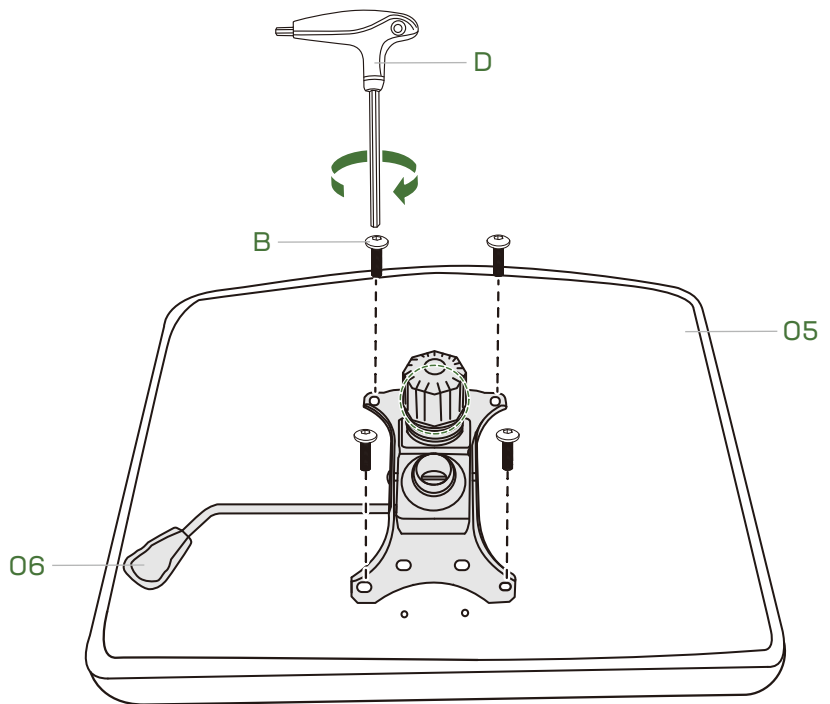
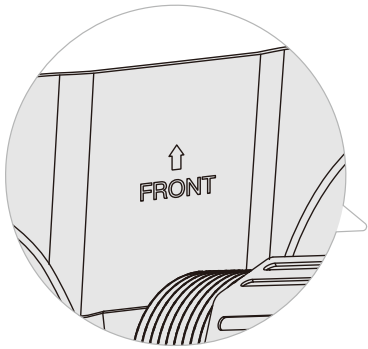

NOTE:
Please note the position of the lever in this step.

Step 5 Assembling the Backrest

Attach the backrest [07] to the seat [05] using bolts [C].
NOTE: Remember to tighten bolts [C] and [B] after this step

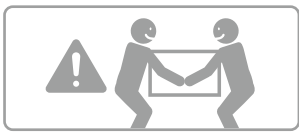

HEAVY! You may need assistance with this step.

NOTE:
You may need to press down on the chair seat from above to align the bolt holes properly.

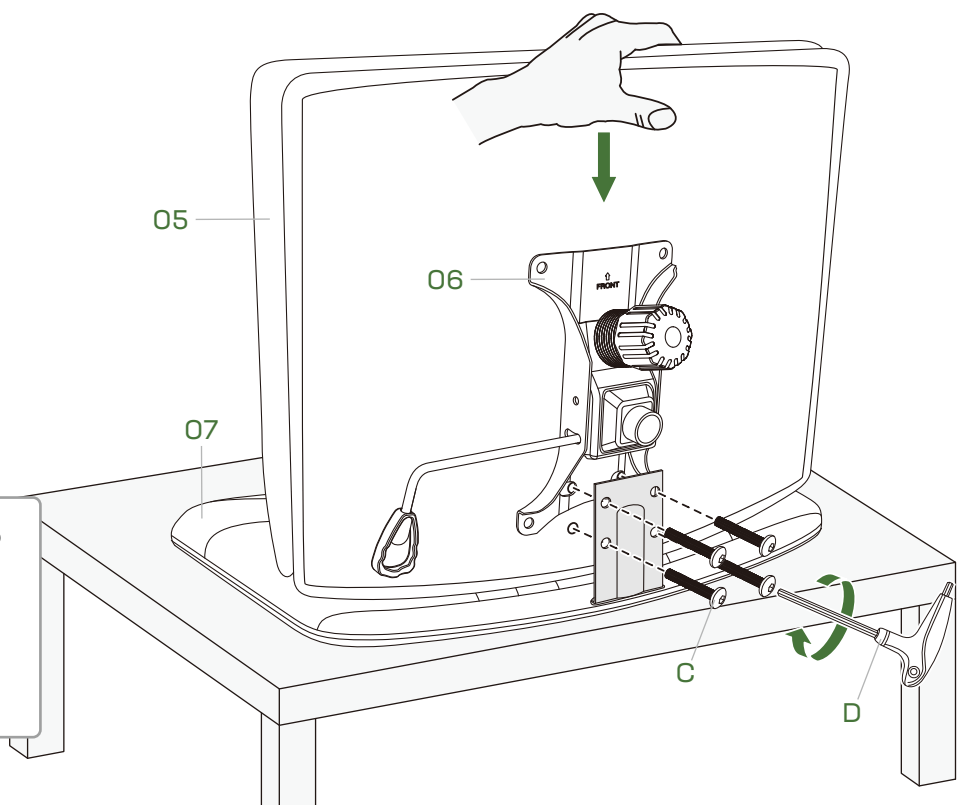

Step 6 Attaching the Chair to the Base

Align the hole underneath the chair with the gas lift cylinder [04]. Press the seat down to secure the chair to the base.



HEAVY! You may need assistance with this step.

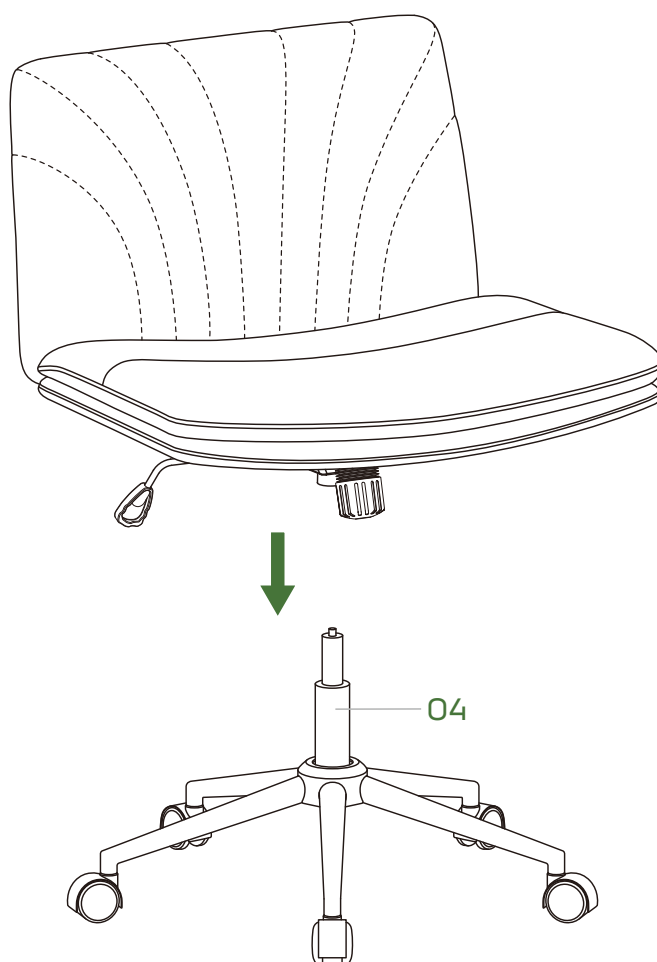

IMPORTANT SAFETY INFORMATION

- Compare package contents to the supplied parts and hardware list to confirm that all parts were received and undamaged. Do not use damaged or defective parts. If you require replacement parts, please email customer service.
- Carefully read all instructions before attempting installation. If you have any questions or concerns, please email customer service.



Only (1) person should sit in the chair at a time.



Only use the chair on level flooring.



Sit correctly in the chair with weight centered over the base.



Do not sit on the edge of the chair.



Do not stand on the chair or use it as a ladder or stair.



To avoid tipping over, do not lift legs up while tilting the backrest.



Children under 5 years of age should not operate the chair alone.

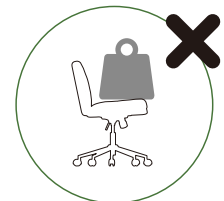

Do not put heavy objects on the chair, or use it as a trolley.

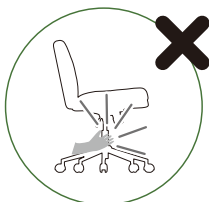

Keep hands away from the seat lift mechanism during operation.

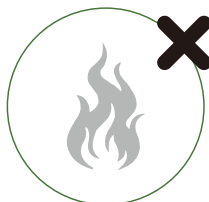

Keep the chair away from flame and heat sources.

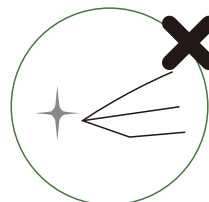

Do not use items with sharp edges or hooks near the chair.

Care And Maintenance

How To Clean

- It is recommended that the office chair be thoroughly cleaned at least once a month to maintain condition and functionality.
- Use a vacuum cleaner to suck up the dirt that may be resting on the seat.
- The casters will stick if not maintained regularly. Brush the casters with water and wipe clean with a damp cloth.
- If dirt solidifies on the surface of the casters, use soap and water to clean it off.
- Use a dry cloth to finish cleaning, or leave your office chair in a ventilated area to air dry.

Maintenance Tips

- Direct sunlight can ruin an office chair over time, degrading most fabrics and materials. Keep your office chair out of direct sunlight.
- Humid conditions may lead to the formation of mildew on fabric and/or rust on metal parts. Do not keep your office chair in a damp environment.
- Be careful with drinks, food, or any type of liquids when you are near your chair. If a spill happens, clean and attend to stains immediately.
- Avoid the use of sharp objects or blades near the office chair that may cause damage.
- If possible, cover the chair to protect it from dirt and dust.
- Regularly examine the chair to ensure that all nuts and bolts are correctly fastened, including those connecting the seat, back, and chair mechanics.
- Retighten bolts every 6 months by using the included Allen key.
- *Using an electric drill can damage the chair. Only use hand tools.

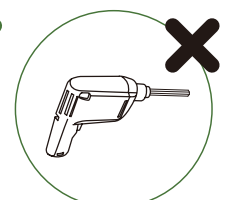
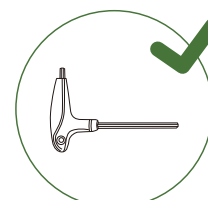

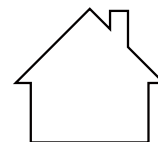
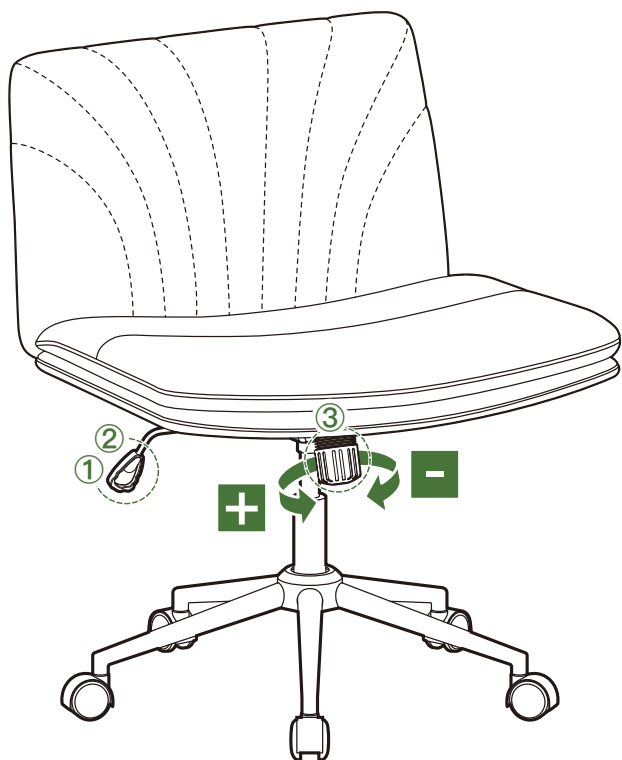

**Uso en oficinas
domésticas**

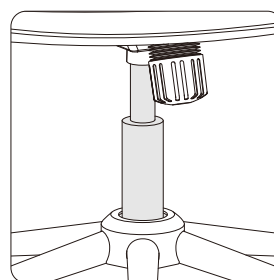

¡ADVERTENCIA! Sólo el personal cualificado puede sustituir o reparar los componentes de regulación de la altura del asiento con acumuladores de energía.

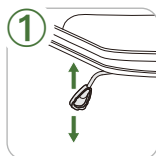

① Ajuste de la altura del asiento:

Para levantar el asiento, levante el cuerpo de la silla y tire de la empuñadura hacia arriba.
Para bajar el asiento, apoye el cuerpo en la silla y tire de la empuñadura hacia arriba.

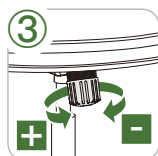

② Función de balanceo del respaldo:

Tire de la empuñadura hacia fuera para activar la función de balanceo. La silla se balancea hacia adelante y hacia atrás con el usuario en lugar de estar bloqueada en una posición fija. Vuelva a colocar la empuñadura en su posición original para bloquearla.

③ Ajuste del ángulo de inclinación del respaldo:

Gire la perilla [+] o [-] para aumentar o disminuir la tensión de balanceo.

Consejo: Se puede regular la tensión para que sea compatible con un peso en particular. Aumente la tensión para un peso mayor y disminuya la tensión para un peso menor.

Paso 1 Piezas y herramientas provistas

01 x 1

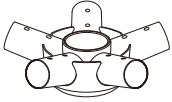

Conector de pata con
tapa decorativa

02 x 5



Pata

A x 10

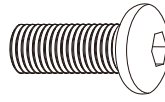

M6 x 14mm
Los Pernos

D x 1

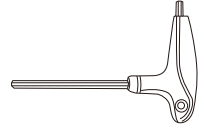

Llave Allen

Paso 2 Piezas y herramientas provistas

03 x 5



Rueda

Paso 3 Piezas y herramientas provistas

04 x 1



Cilindro Elevador de Gas

Paso 4 Piezas y herramientas provistas

05 x 1



Asiento

06 x 1

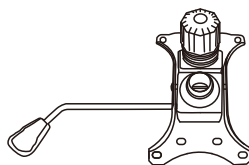

Mecanismo de Elevación

B x 4

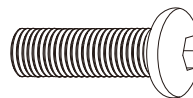

M6 x 18mm
Los Pernos

D x 1

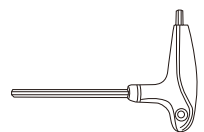

Llave Allen

Paso 5 Piezas y herramientas provistas

07 x 1

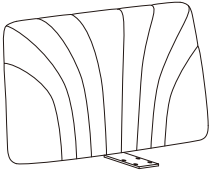

Respaldo

C x 4

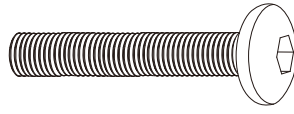

M6 x 30mm
Los Pernos

D x 1

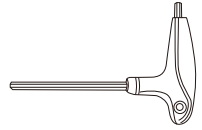

Llave Allen

Apoyo



Proporcionamos guantes que se pueden usar durante la instalación.

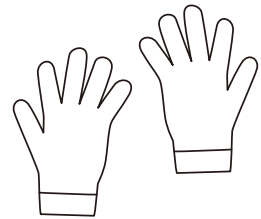

Paso 1 Montaje de las patas de la silla

Introduzca las patas [02] en el conector de las patas [01a] y fíjelas con los pernos [A].

Retire la cubierta decorativa y guárdela para el Paso 3.

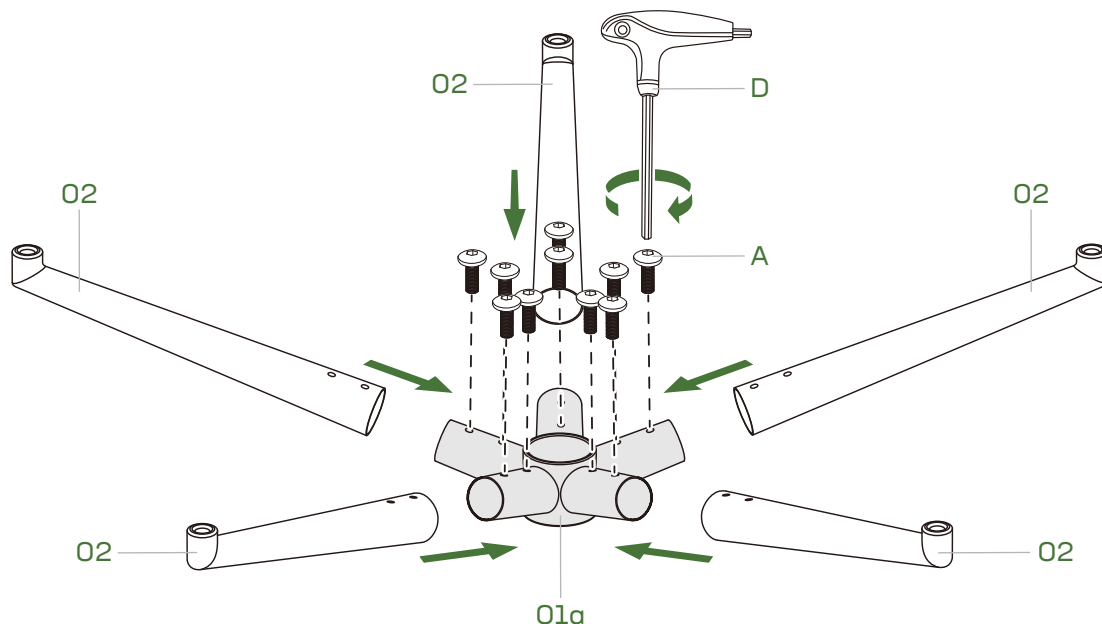
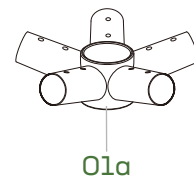
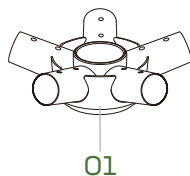

Paso 2 Ensamblaje de las ruedas giratorias

Presione las ruedas [03] de manera firme dentro de los agujeros de los apoyapiés [02].

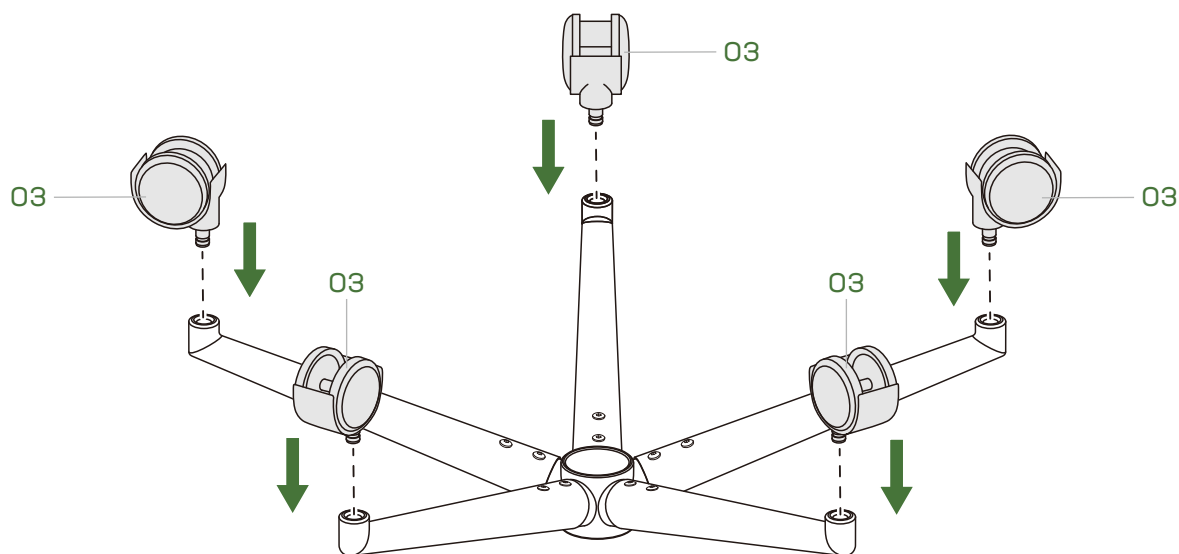

Paso 3 Montaje de la base de la silla

Dé la vuelta a la base montada y coloque la cubierta decorativa [01b]. Presione el cilindro elevador de gas [04] en el conector de la pata.

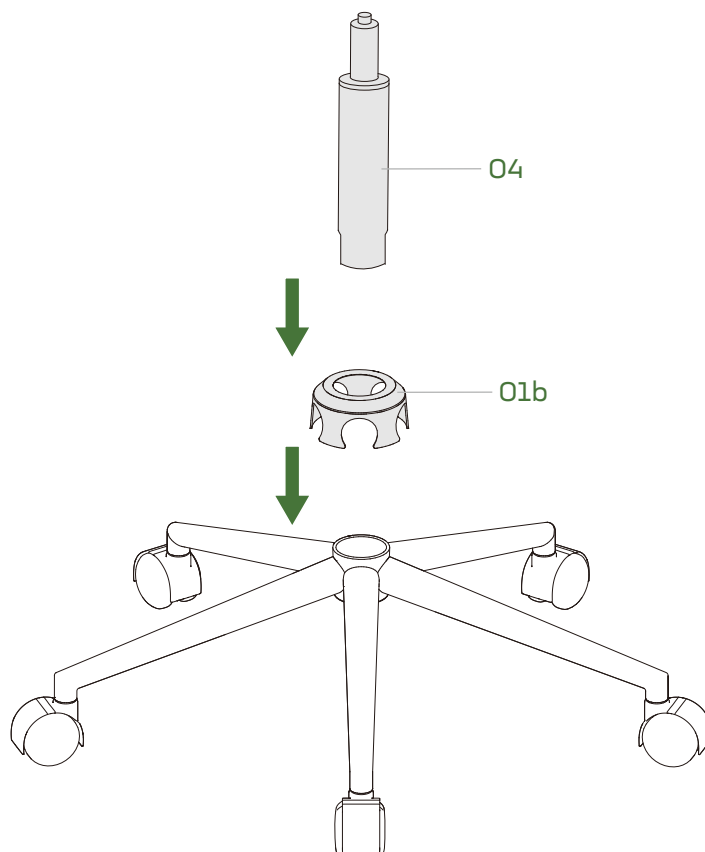

Paso 4 Fijación el mecanismo de elevación

Use los pernos [B] para fijar el mecanismo de elevación [06] al asiento [05].
NOTA: no sobreapriete los tornillos [B] hasta que haya finalizado el Paso 5.

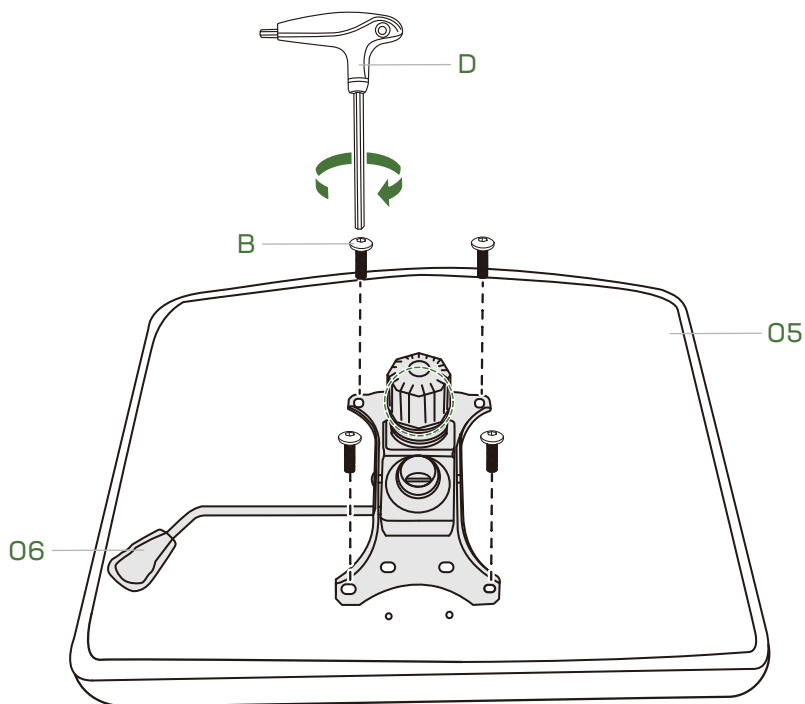
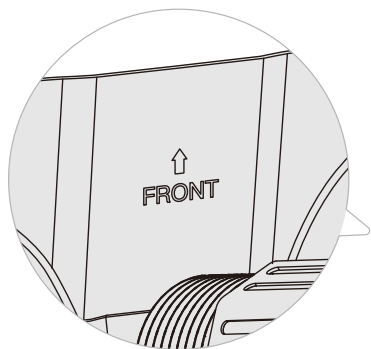

NOTA:

tenga en cuenta la posición de la palanca en este paso.

Paso 5 Montaje de los del respaldo

Use los pernos [C] para fijar el respaldo [07] al asiento [05].
NOTA: Recuerde apretar los tornillos [C] y [B] después de este paso.



¡OBJETO PESADO!
Es posible que necesite asistencia en este paso.

NOTA:

Es posible que deba presionar hacia abajo el asiento desde arriba para alinear los agujeros para pernos de manera adecuada.

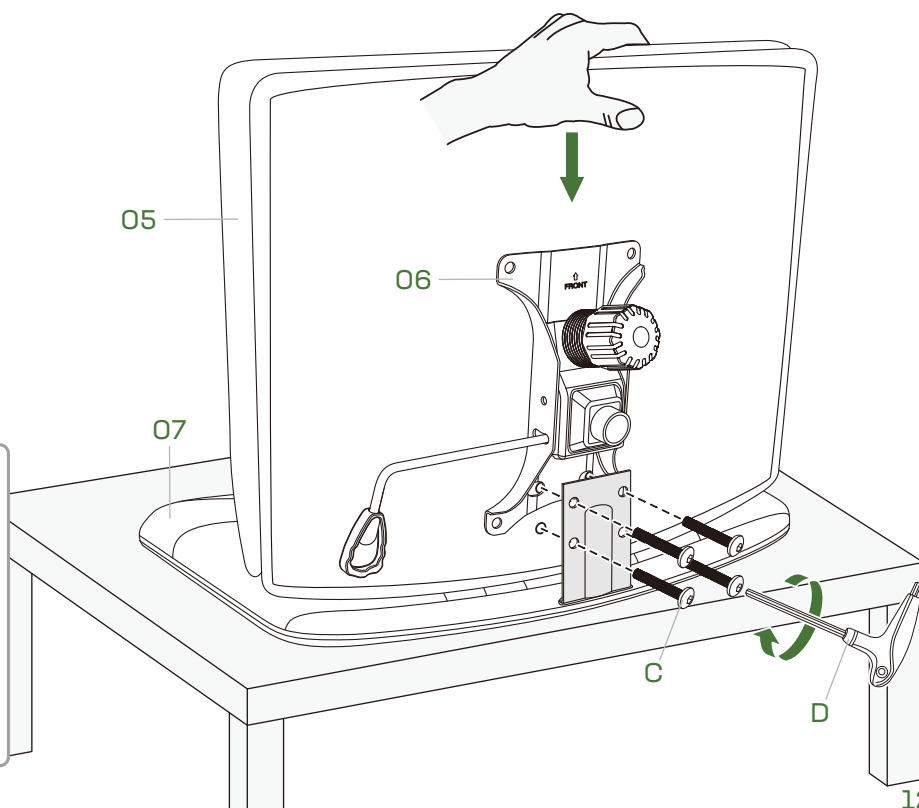

Paso 6 Fijación de la silla a la base

Alinee el orificio debajo de la silla con el cilindro de elevación de gas [04]. Presione el asiento hacia abajo para asegurar la silla a la base.



¡OBJETO PESADO!
Es posible que
necesite asistencia
en este paso.

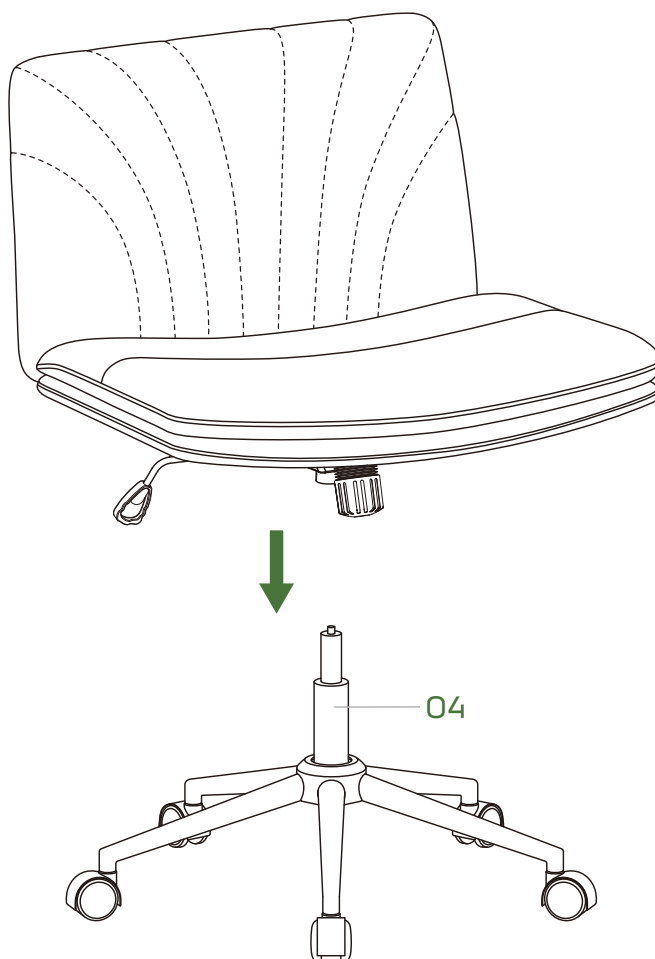

INFORMACIÓN IMPORTANTE DE SEGURIDAD

- Compare los contenidos del paquete en relación con la lista de piezas suministradas y hardware para confirmar que se han recibido todas las piezas y no presentan daños. No use piezas defectuosas o que presenten daños. Si necesita piezas de sustitución, envíe un correo electrónico al servicio de atención al cliente.
- Lea cuidadosamente todas las instrucciones antes instalar. Si tiene alguna consulta o duda, contáctese por correo con nuestro servicio de atención al cliente.



Sólo (1) persona debe sentarse en la silla a la vez.



Utilice la silla sólo en suelos nivelados.



Siéntese en la silla con el peso centrado sobre la base.



No se siente en el borde de la silla.

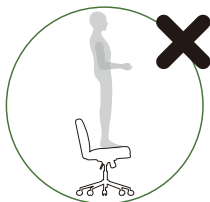

No se suba a la silla ni la utilice como escalera o peldaño.



Para evitar que se vuelque, no levante las piernas hasta que se incline el respaldo.



Los niños menores de 5 años no deben utilizar la silla cuando están solos.

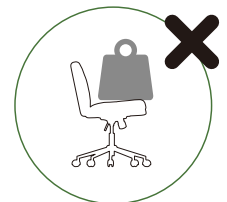

No coloque objetos pesados sobre la silla ni la utilice como carro.



Mantenga las manos alejadas del mecanismo de elevación del asiento durante su funcionamiento.

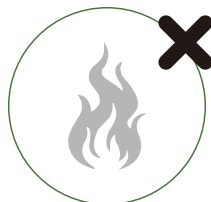

Mantenga la silla alejada de llamas y fuentes de calor.

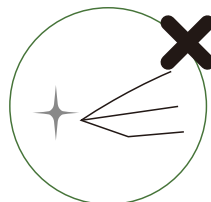

No utilice objetos con bordes afilados o ganchos cerca de la silla.

Cuidado y Mantenimiento

Cómo limpiarla

- Se recomienda limpiar bien la silla de oficina por lo menos una vez al mes para mantener un buen estado y funcionalidad.
- Use una aspiradora para sacar toda la suciedad que se acumule en el asiento.
- Use un paño húmedo para limpiar el apoyabrazos.
- Las ruedas se atorarán si no se les realiza un mantenimiento frecuente. Cepille las ruedas con agua y séquelas con un paño húmedo.
- Puede usar jabón y agua para limpiar cualquier suciedad que se haya solidificado en la superficie de las ruedas.
- Utilice un paño seco para terminar de limpiar o deje la silla de oficina en un lugar ventilado para que se seque al aire.

Consejos de mantenimiento

- La luz solar directa puede arruinar la silla de oficina a lo largo del tiempo, deteriorando las telas y materiales. Mantenga su silla de oficina lejos de la luz solar directa.
- Las condiciones de humedad pueden provocar la formación de moho en el tejido y/u óxido en las piezas metálicas. No guarde la silla de oficina en un ambiente húmedo.
- Tenga cuidado con las bebidas, comida o cualquier otro tipo de líquido cerca de su silla. Si se produce un derrame, limpie y elimine las manchas inmediatamente.
- Evite el uso de objetos afilados o cuchillas cerca de la silla de oficina que puedan causar daños.
- Si es posible, cobra la silla para protegerla de la suciedad y el polvo.
- Revise con frecuencia su silla para asegurarse que todas las tuercas y pernos estén ajustados, incluyendo los del asiento, brazos, y respaldo, así como también los del mecanismo de la silla.
- Vuelva a apretar los pernos cada 6 meses usando la llave Allen que se incluye.
- * El uso de un taladro eléctrico puede dañar la silla. Solo utilice herramientas manuales.

