

Assembly Instructions

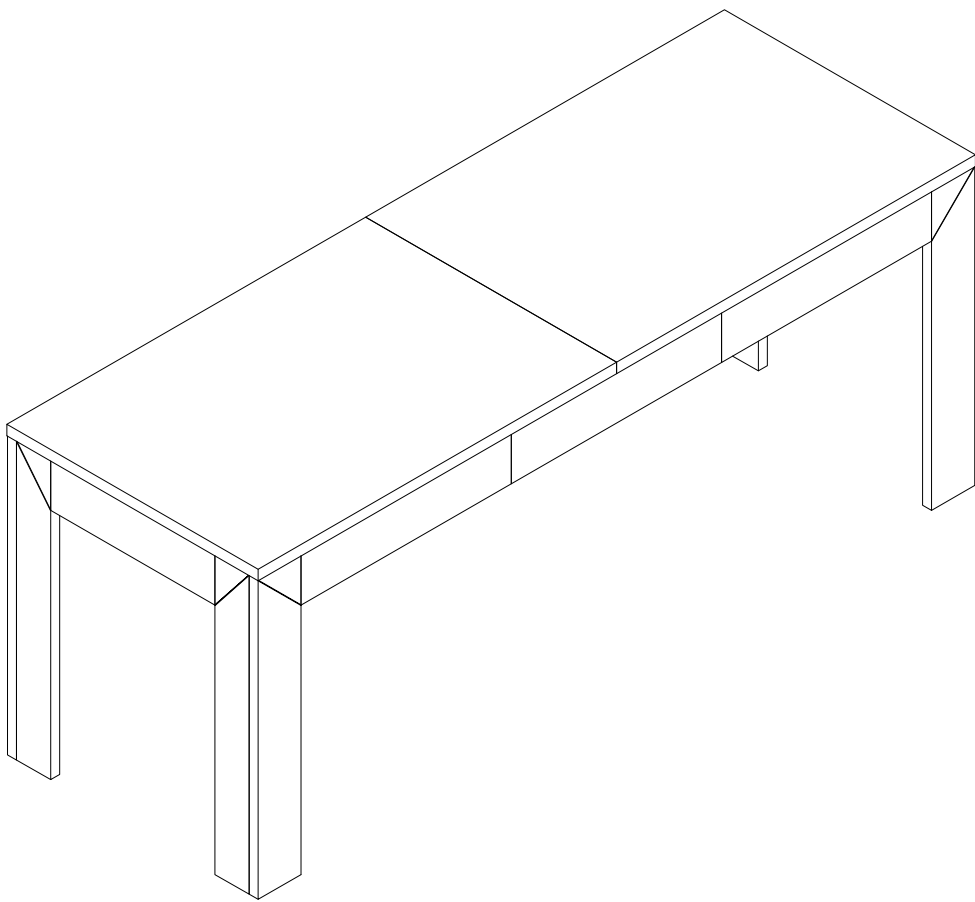

Office Table

Contact Us

We're here to help you.

Your satisfaction is our top priority. If you encounter any issues with this product, such as missing or damaged parts, we're here to help. Please retain the original packaging and take photos of the packaging and the product, then contact us as soon as possible.

Warm Tips

1. Carefully read these instructions and keep them for future reference.
2. Check the parts list and confirm everything's there before starting assembly.
3. When assembling, put all parts on a soft, smooth surface like a carpet to avoid scratches.
4. Don't fully tighten screws until all parts are confirmed in place to avoid misalignment.

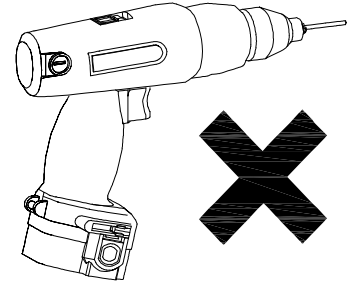
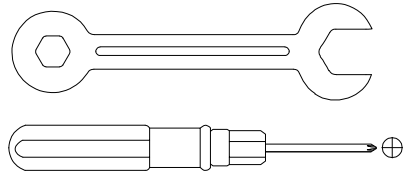
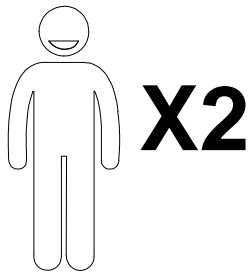

We recommend using hand tools for assembly.

If an electric screwdriver is used, reduce power and torque to avoid damage to the product.

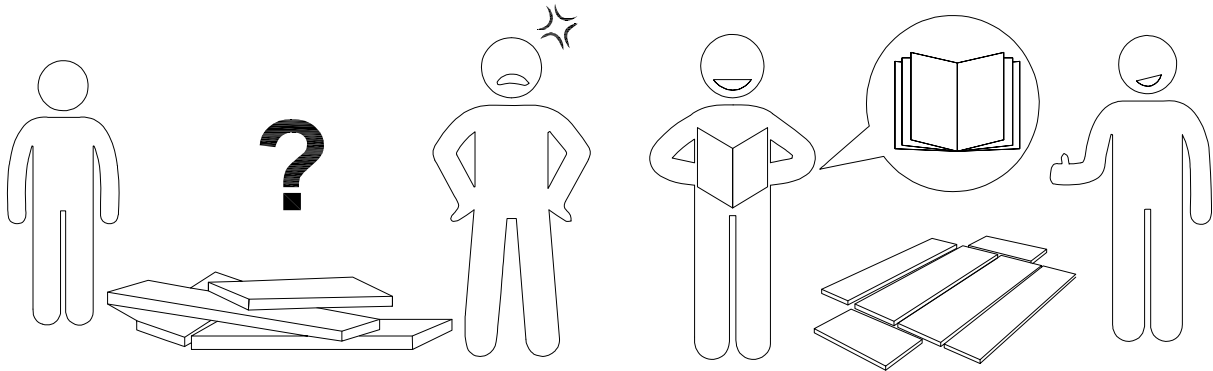

AVOID SCRATCHES

In order to avoid scratching, this furniture should be assembled on a soft surface, such as a rug.

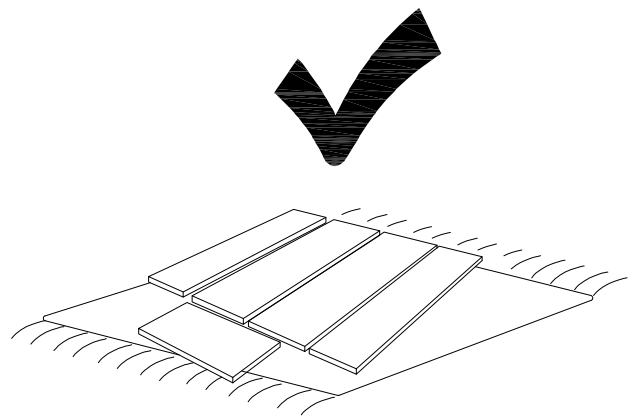
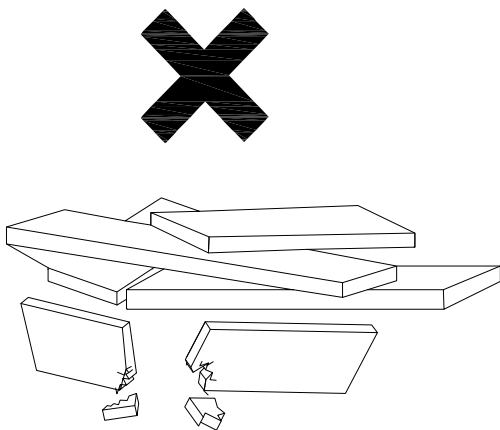

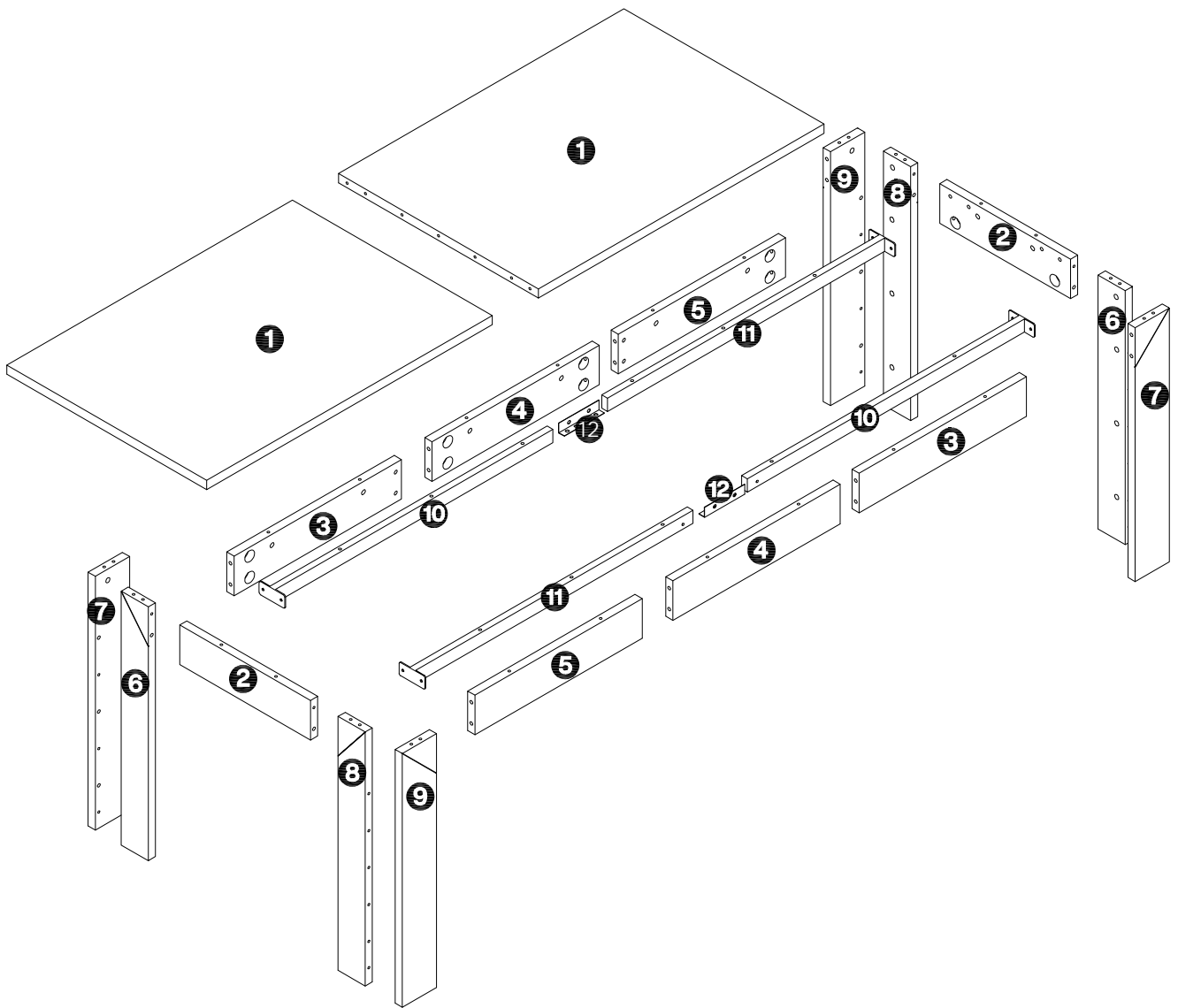





 **Caution**

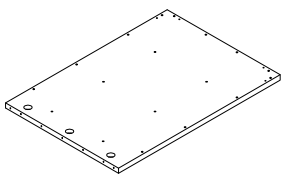
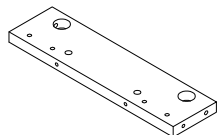
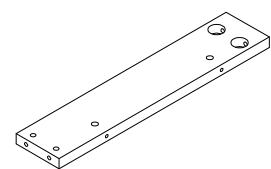
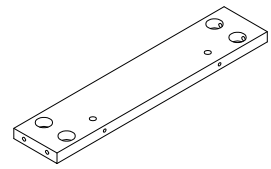
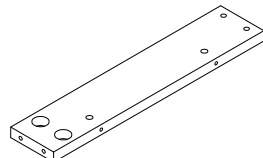
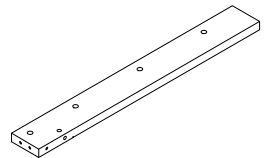
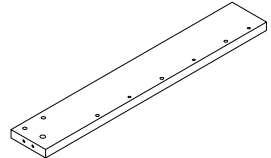
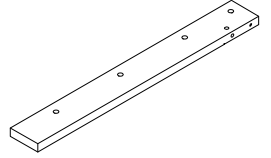
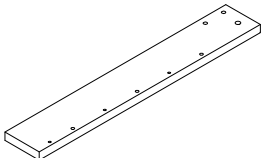
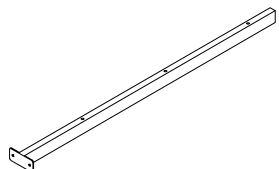
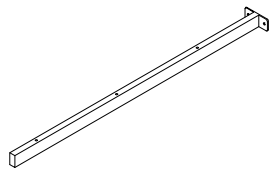
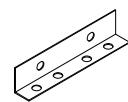



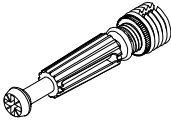
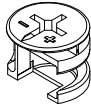

Make sure all parts are included. Most board parts are labeled or stamped on the raw edge. Contact us for a free replacement if you encounter any damaged or missing parts.

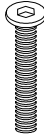
Parts List

<p>1</p>  <p>2 pcs</p>	<p>2</p>  <p>2 pcs</p>	<p>3</p>  <p>2 pcs</p>	<p>4</p>  <p>2 pcs</p>
<p>5</p>  <p>2 pcs</p>	<p>6</p>  <p>2 pcs</p>	<p>7</p>  <p>2 pcs</p>	<p>8</p>  <p>2 pcs</p>
<p>9</p>  <p>2 pcs</p>	<p>10</p>  <p>2 pcs</p>	<p>11</p>  <p>2 pcs</p>	<p>12</p>  <p>2 pcs</p>

Hardware List

A	B	C	D	E	F
					
Ø6x40mm	Ø15x12mm	Ø8x30mm	Ø8x15mm	Ø8x20mm	Ø6x55mm
36 pcs	36 pcs	28 pcs	12 pcs	8 pcs	12 pcs

G	H	I	J	K	L
					
Ø8x80mm					
23 pcs	26 pcs	26 pcs	20 pcs	8 pcs	12 pcs

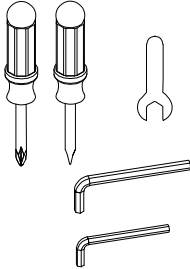
M					
					
1 pc					

Installation of Cams and Pins

Step 1-2: Align the plastic part with the mounting hole and press it in. If you can't press it in, loosen the screw counter clockwise or completely remove the screw from the plastic part and try again.
Step 3-4: After pressing the plastic part into place, use a screwdriver to tighten the screw clockwise.

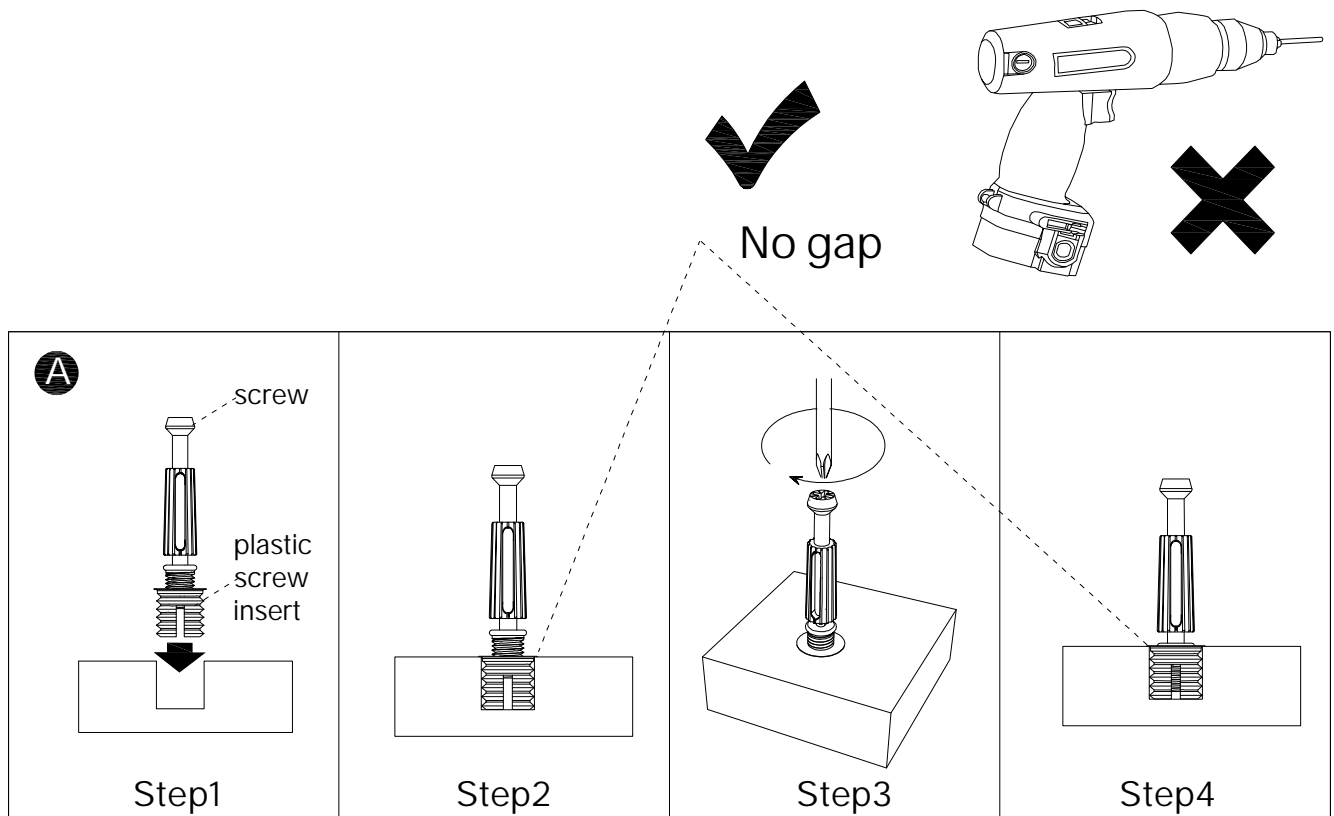

Screw the pin into the hole. Set the cams correctly by aligning the head of the cams with the lock pins. Lock the cam by turning the cam head with a screwdriver until it is tightened. Please do not use an electric screwdriver to assemble the unit.

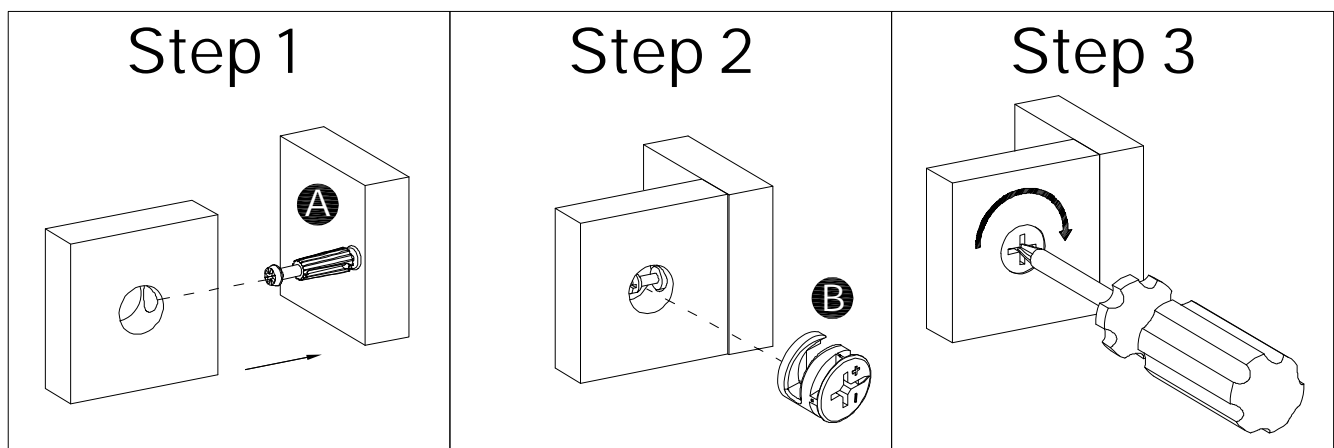

1

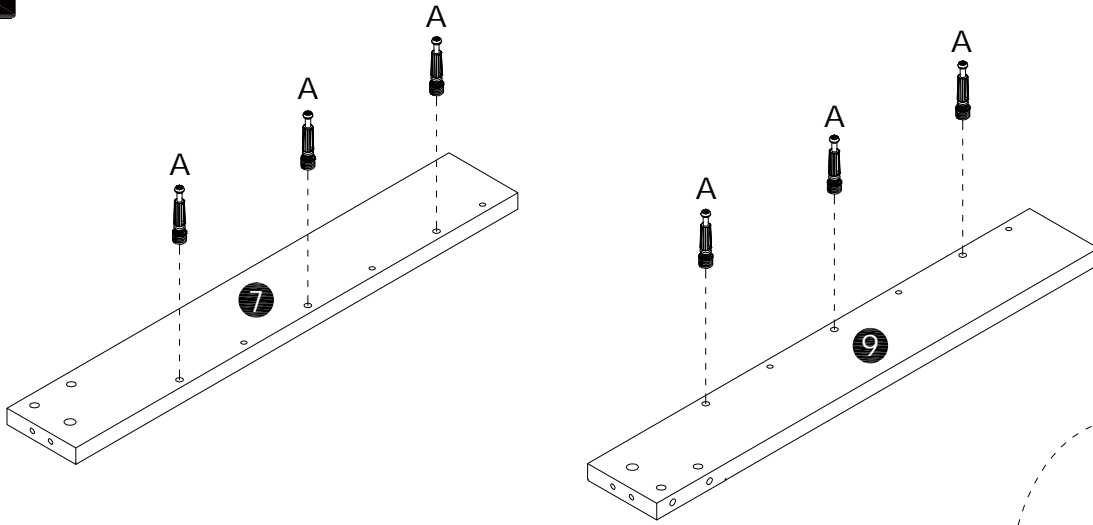

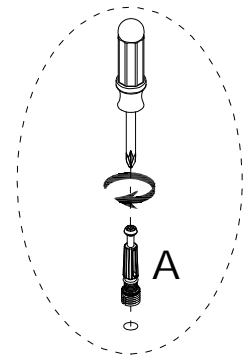

A

Ø6x40mm
12 pcs

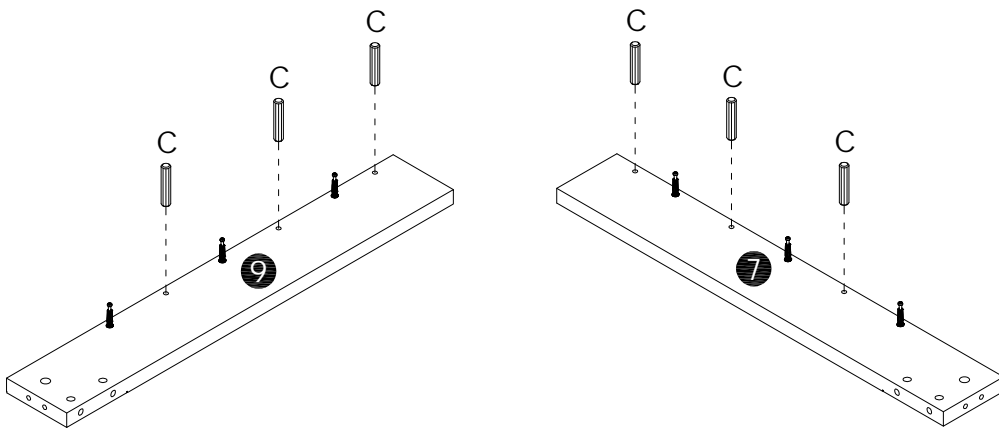

X2

2



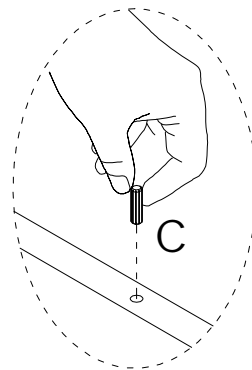

C

Ø8x30mm
12 pcs

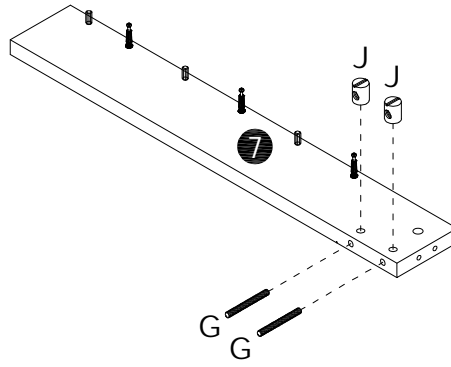
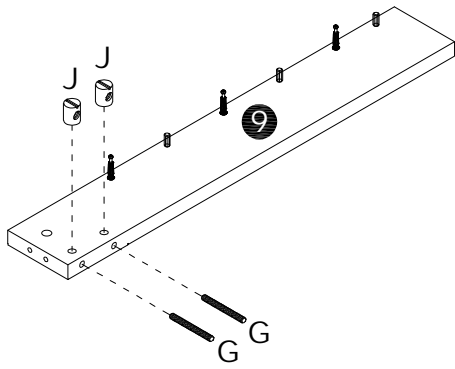

X2

3



G

Ø8x80mm
8 pcs
J

8 pcs

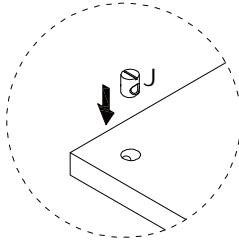
Step 1

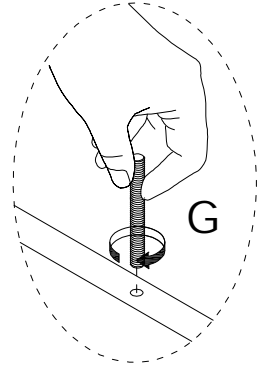
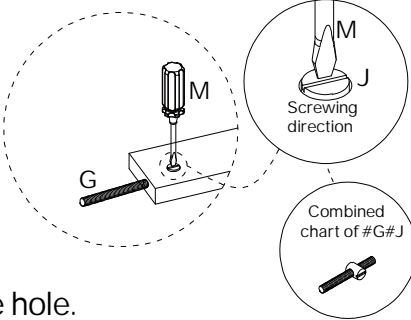

Step 2





Step 1: Insert #J into the hole.

Step 2: Using a screwdriver, rotate #J until its groove aligns with #G. Lock in place by turning #G clockwise.

X2

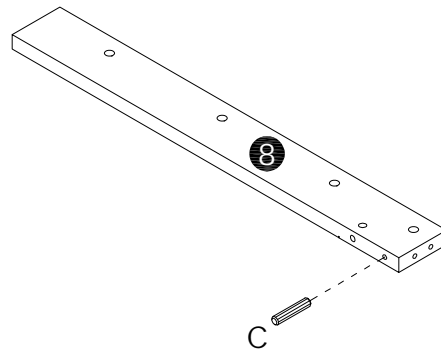
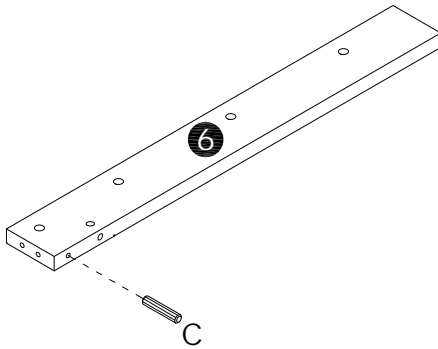
4



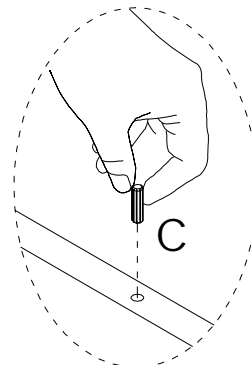

C

Ø8x30mm
4 pcs

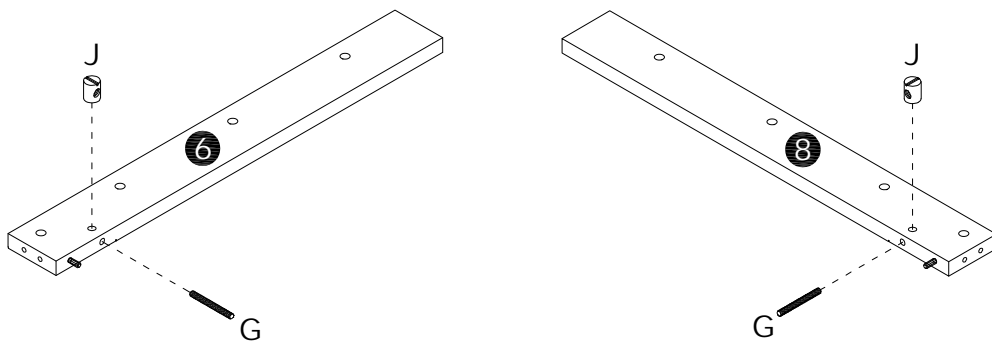

X2

5



G

Ø8x80mm
4 pcs
J

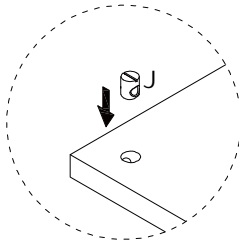
4 pcs

Step 1

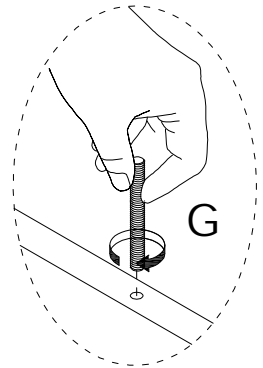
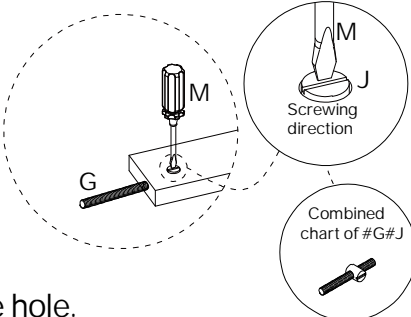

Step 2





Step 1: Insert #J into the hole.

Step 2: Using a screwdriver, rotate #J until its groove aligns with #G. Lock in place by turning #G clockwise.

X2

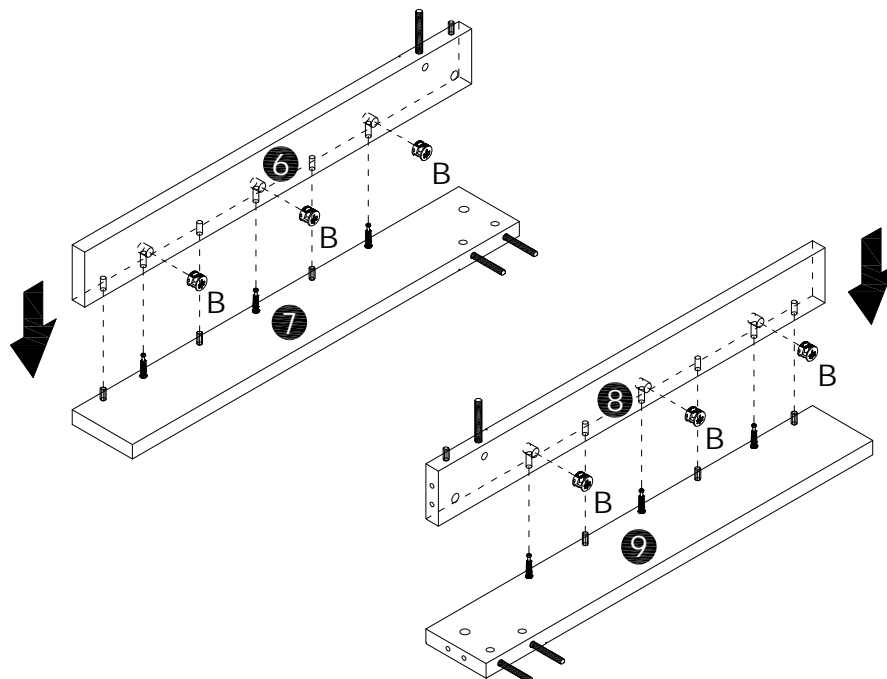
6



B

Ø15x12mm
12 pcs

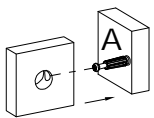
Step 1

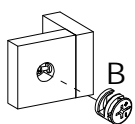

Step 2



Step 3

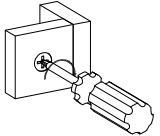

X2

7

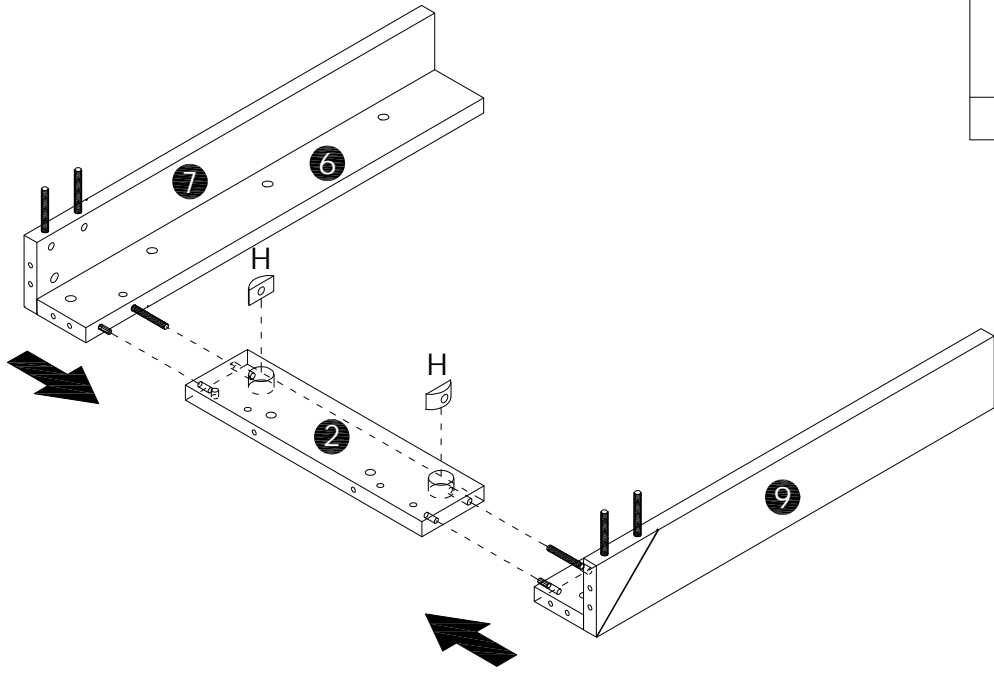

H
4 pcs

X2

8

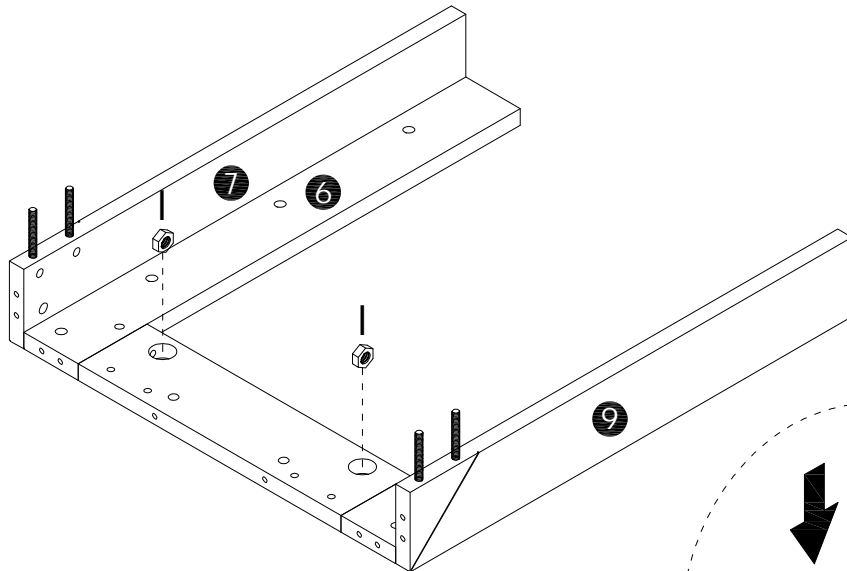

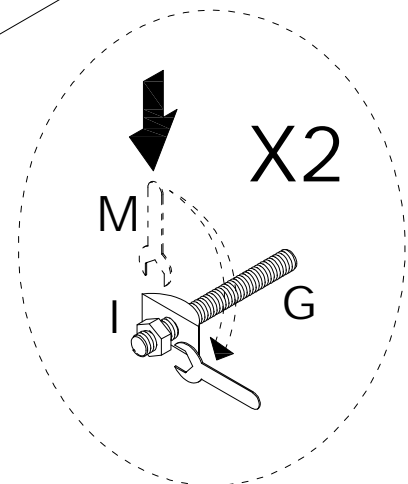

I
4 pcs

X2

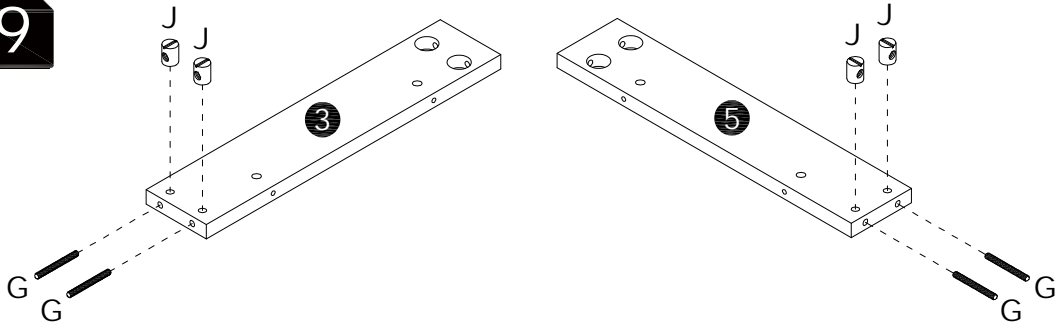

9

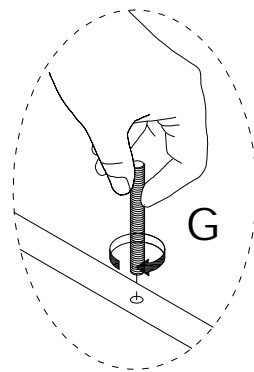
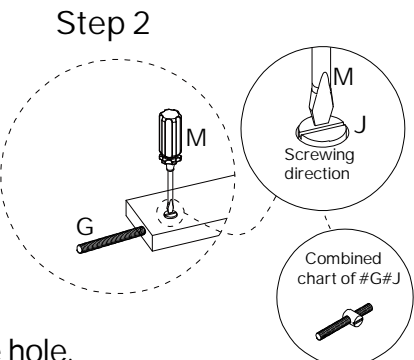
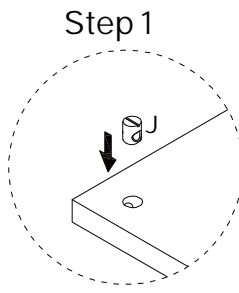

G

Ø8x80mm
8 pcs
J

8 pcs





Step 1: Insert #J into the hole.

Step 2: Using a screwdriver, rotate #J until its groove aligns with #G. Lock in place by turning #G clockwise.

X2

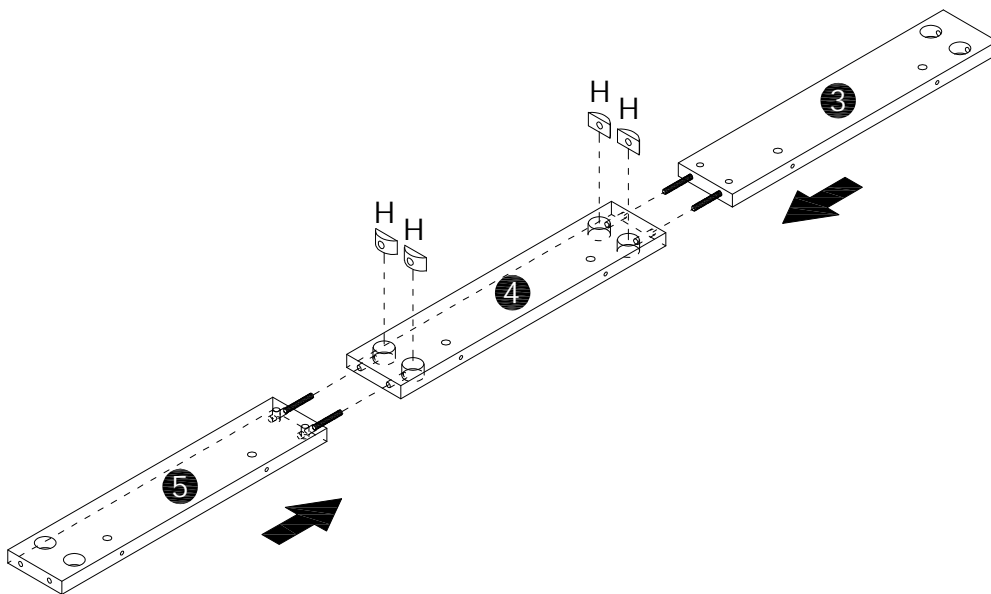
10



H

8 pcs

X2

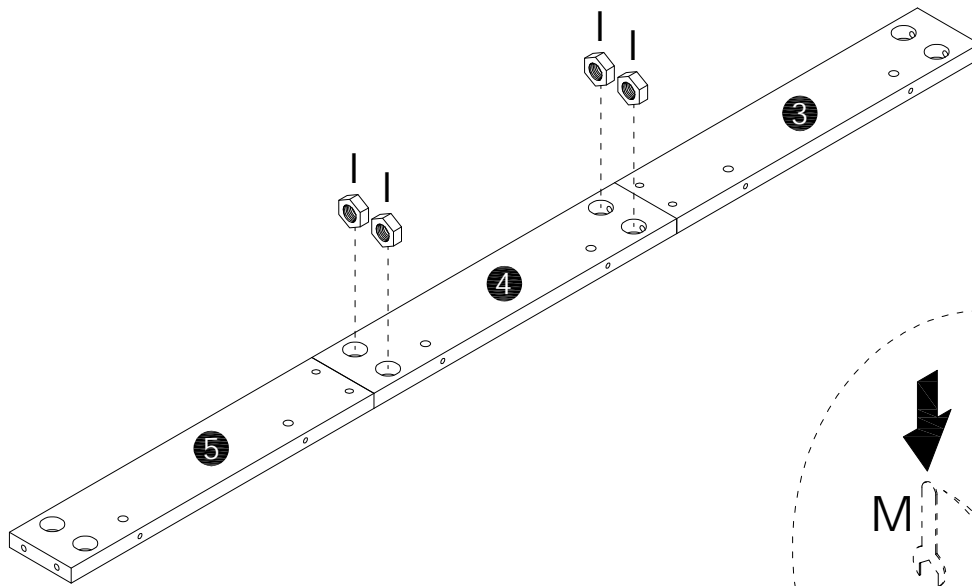
11



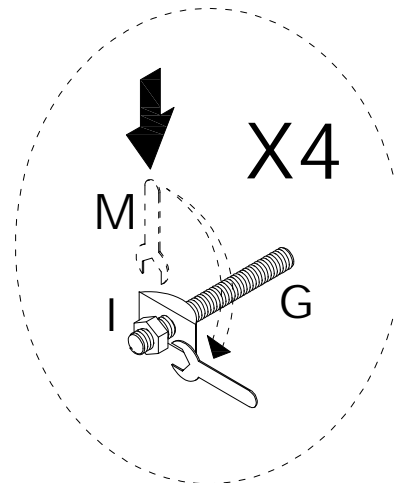

I

8 pcs

X2

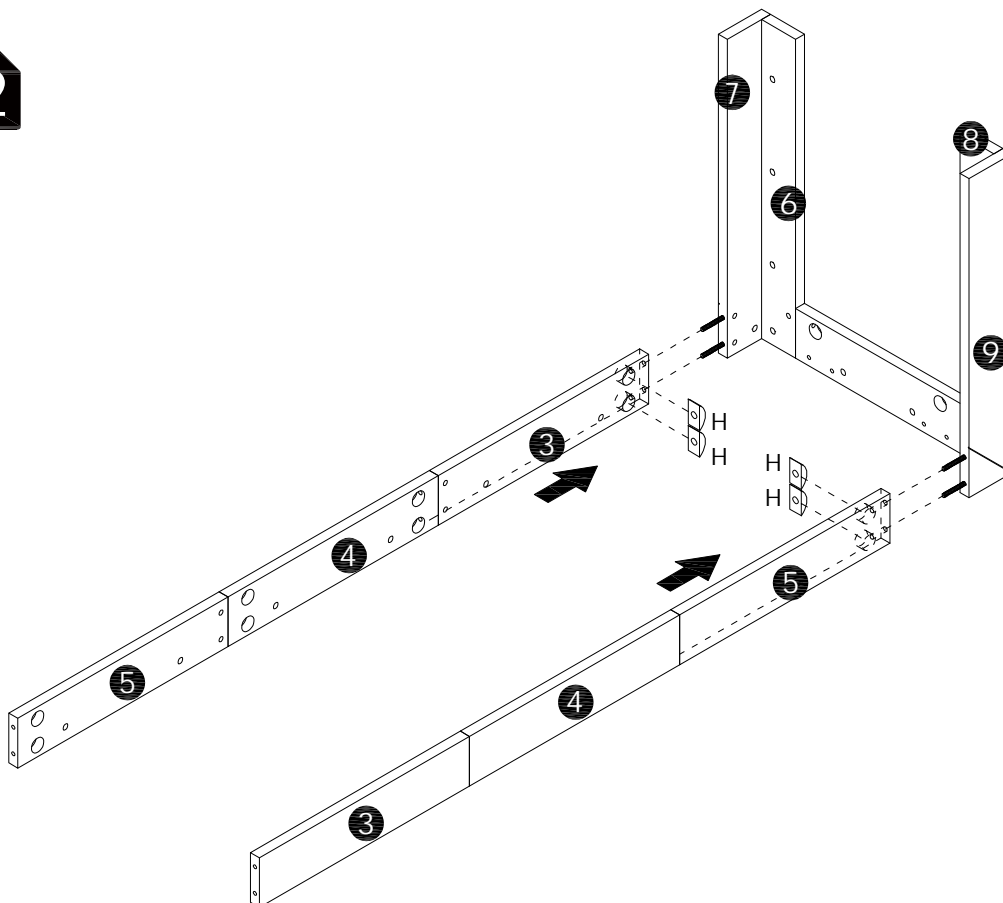



12

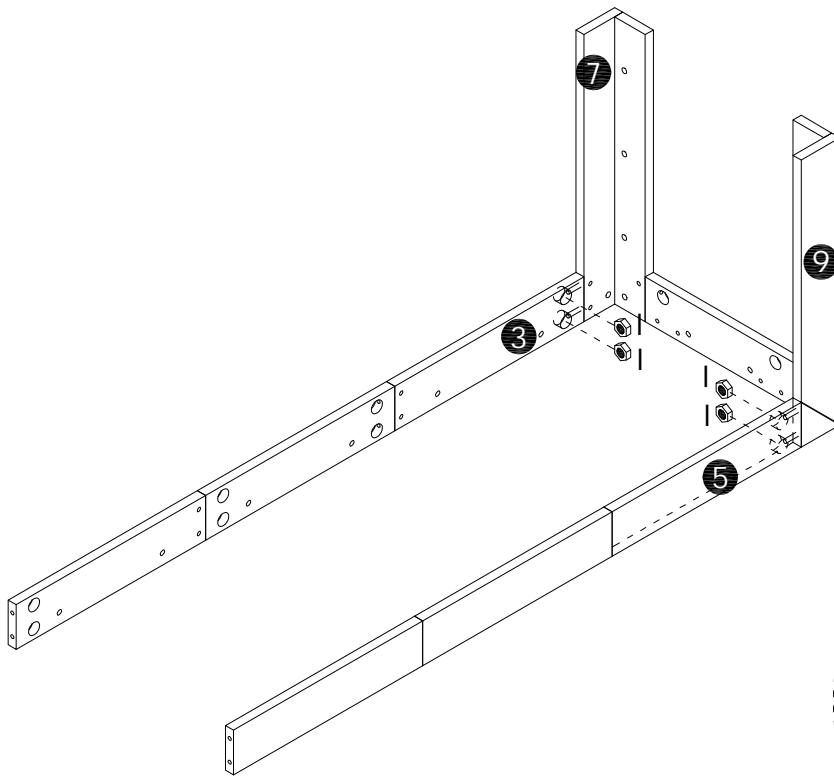

H

4 pcs

13

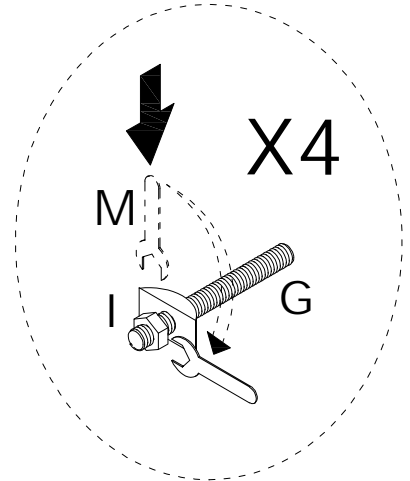

I

4 pcs

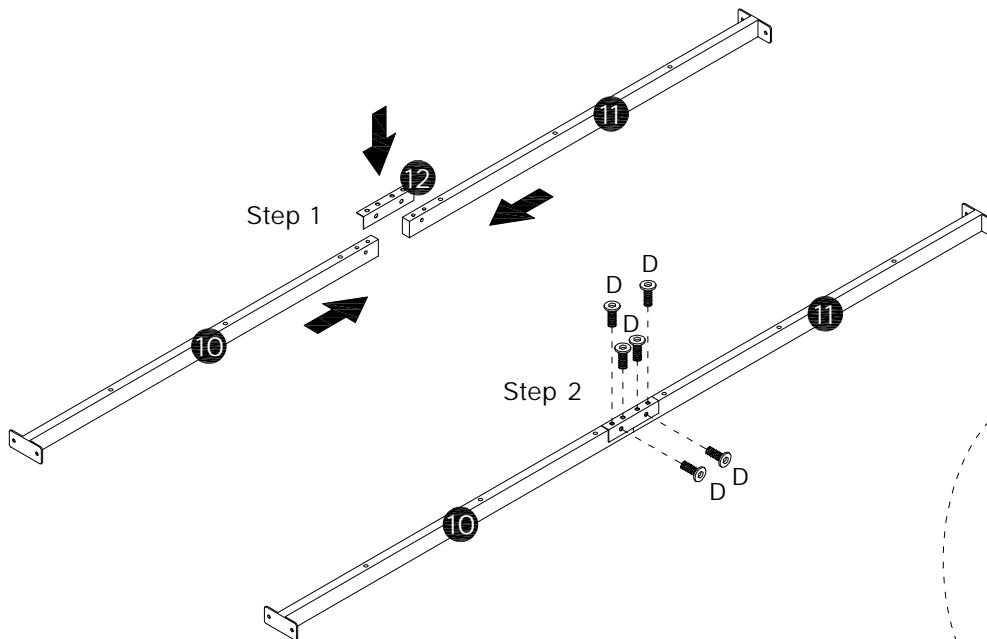

14



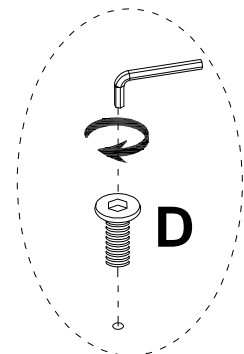

D

Ø8x15mm
12 pcs

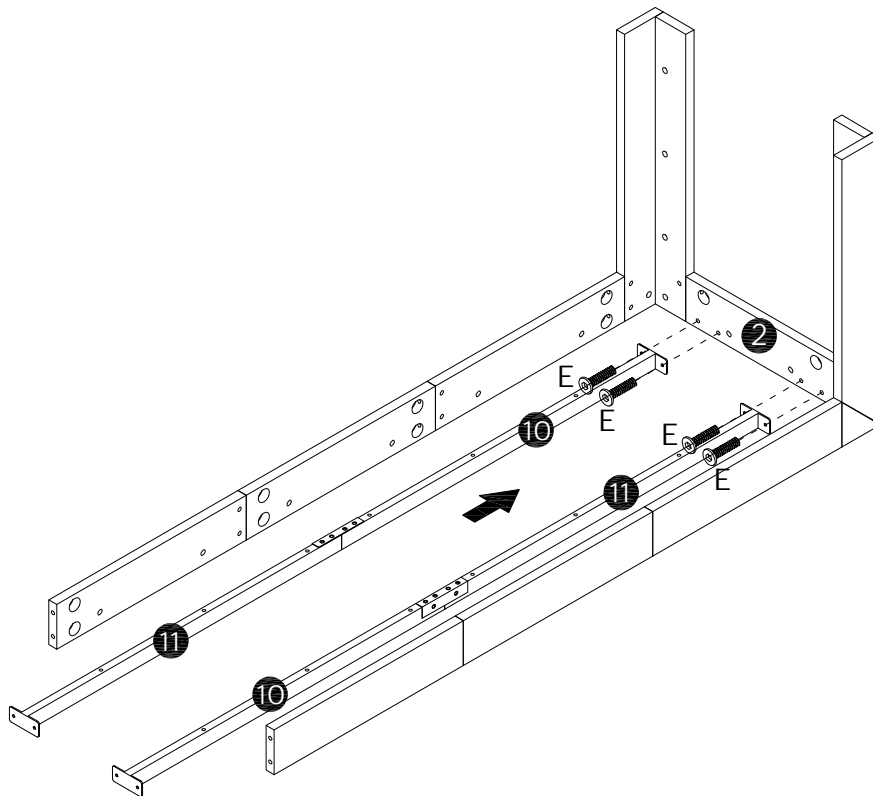

X2

15

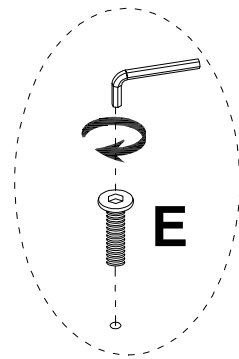

E

Ø8x20mm
4 pcs



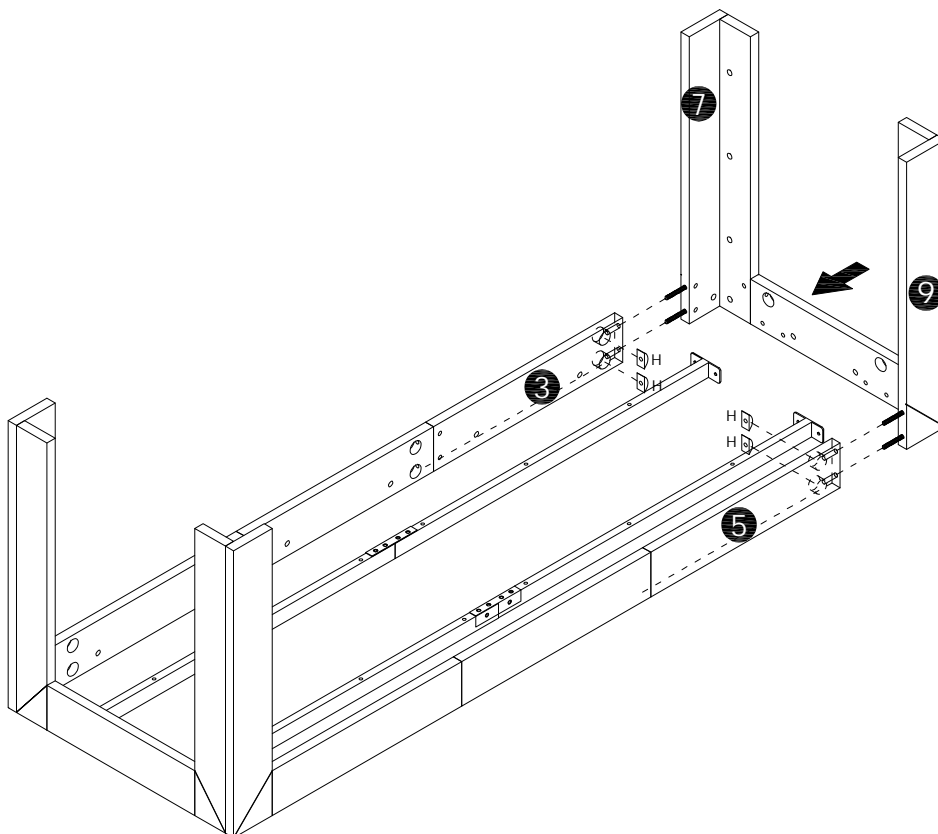

16

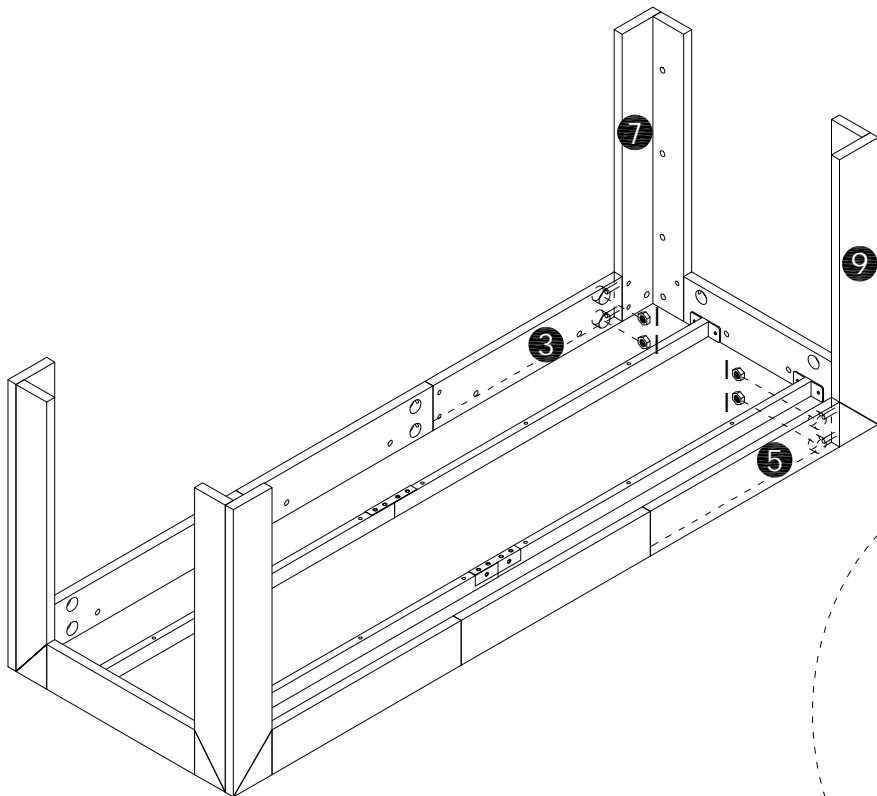

H

4 pcs

17

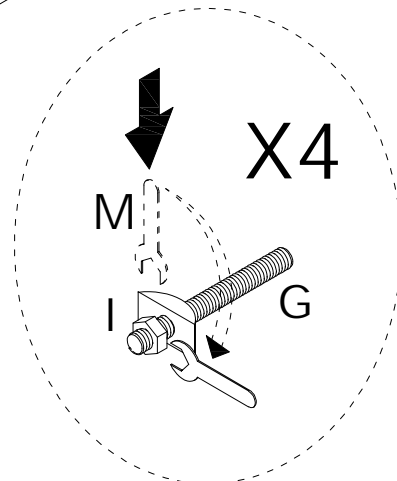

I

4 pcs

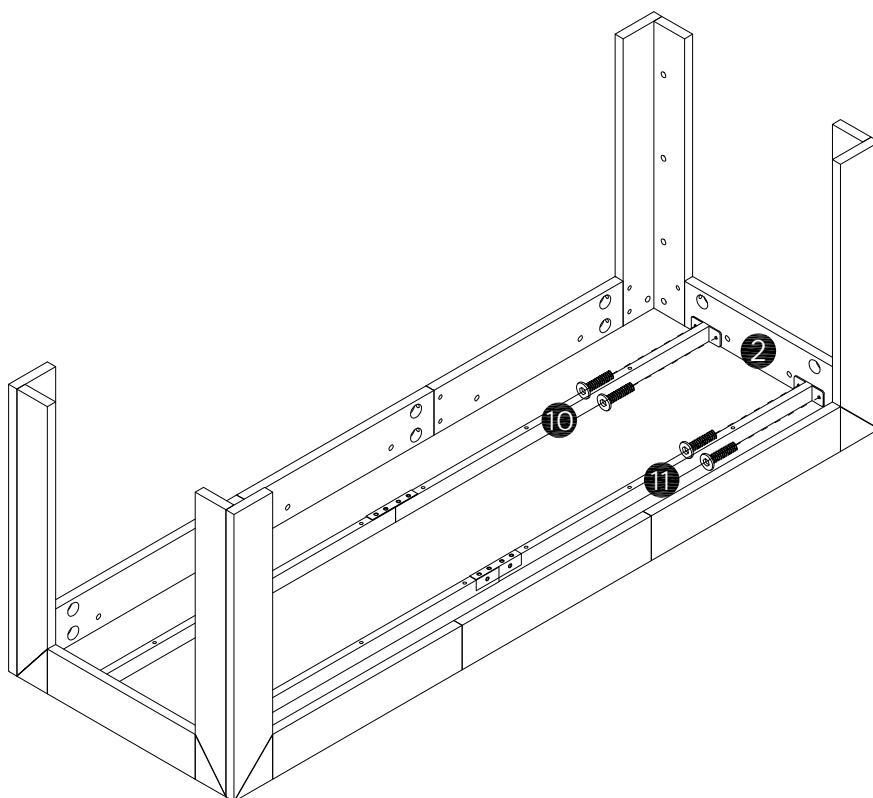

18

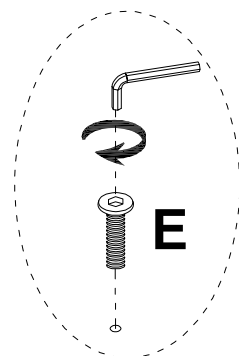

E

Ø8x20mm
4 pcs

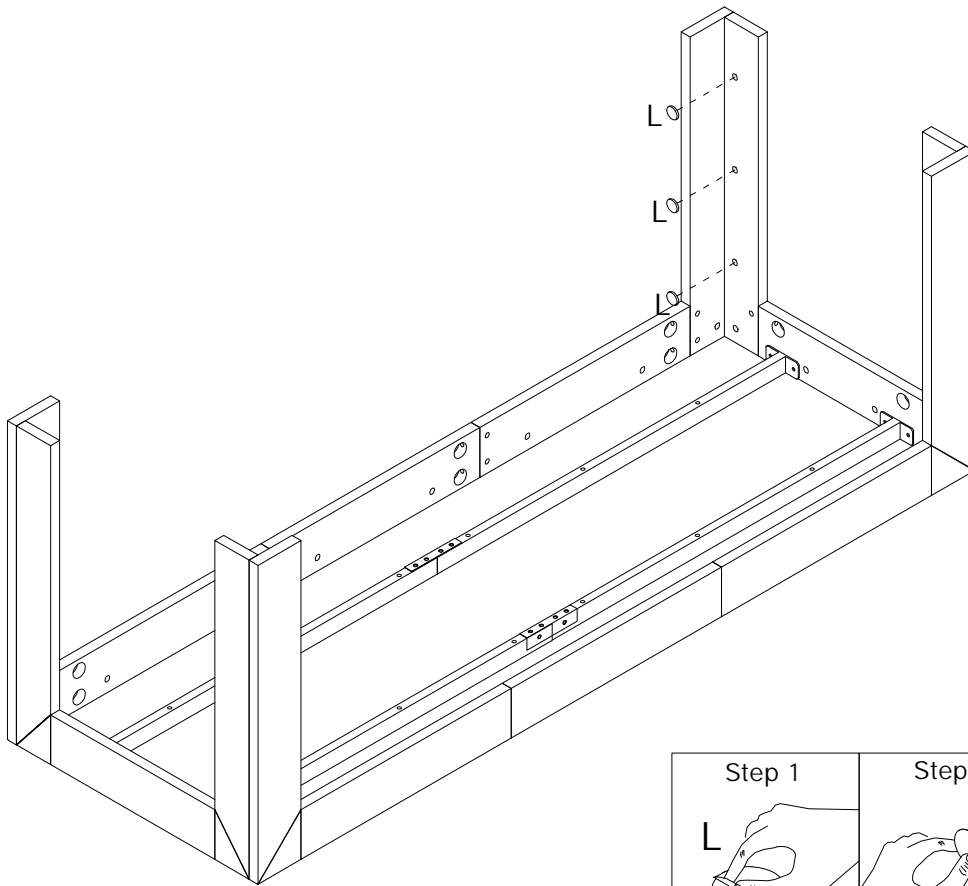

19

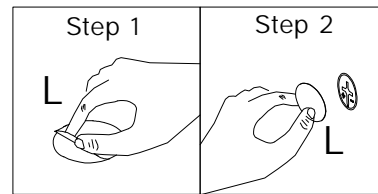

L
12 pcs



20

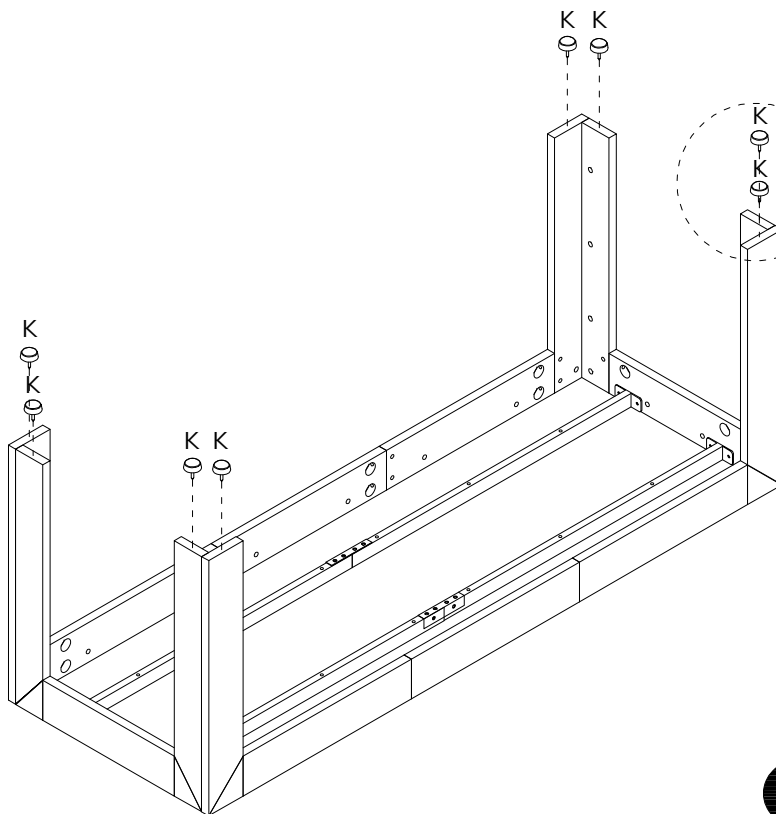

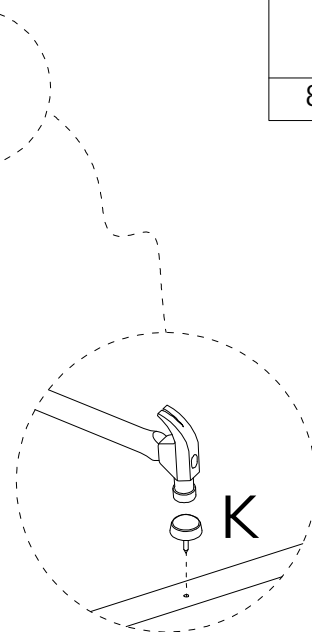

K
8 pcs

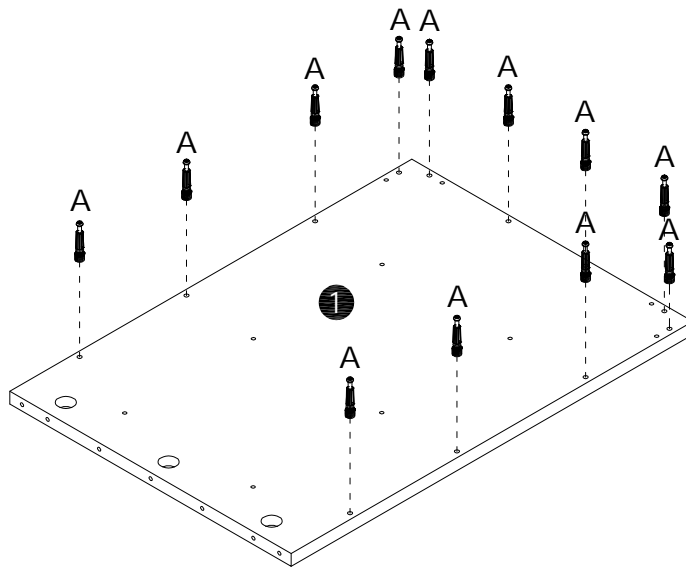

⚠ Caution! Tap lightly

21



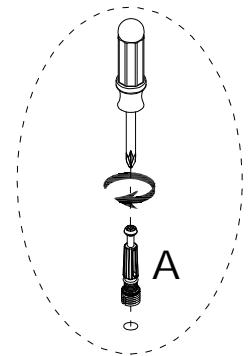

A

Ø6x40mm
24 pcs

X2

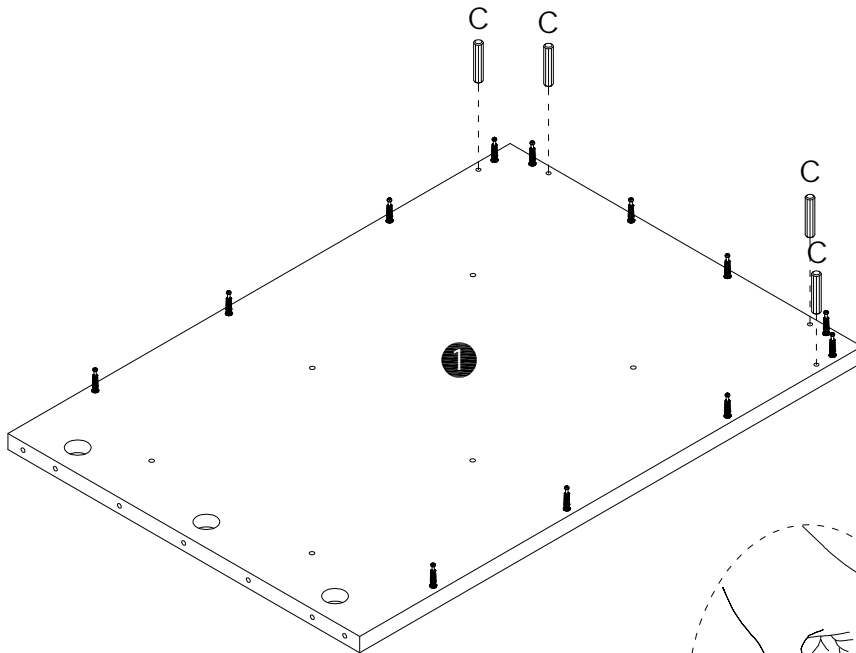

22





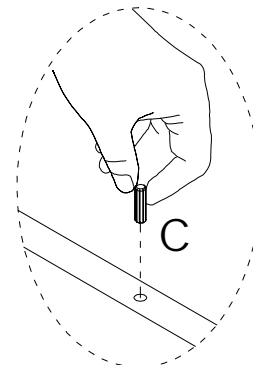

C

Ø8x30mm
8 pcs

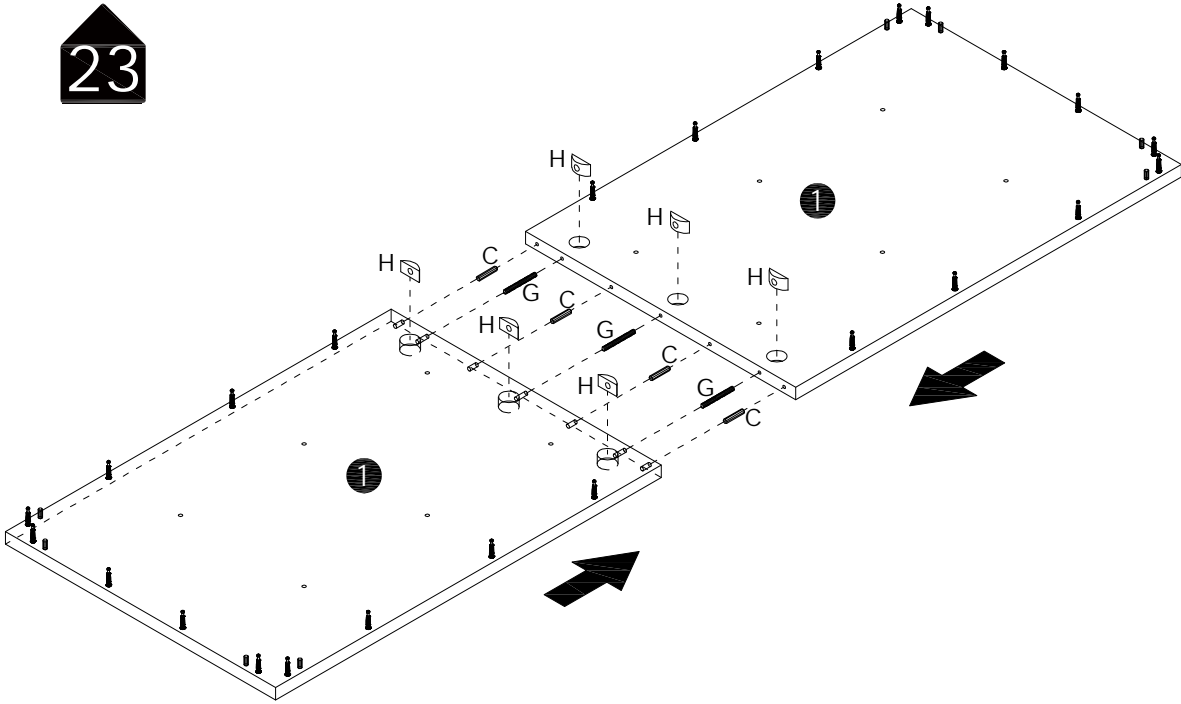
X2





23

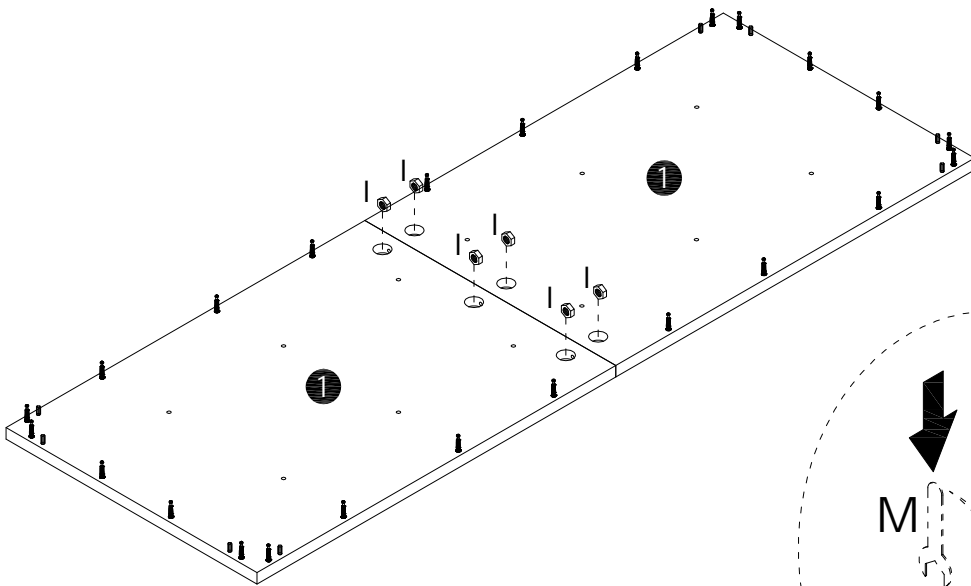

C

Ø8x30mm
4 pcs
G

Ø8x80mm
3 pcs
H

6 pcs

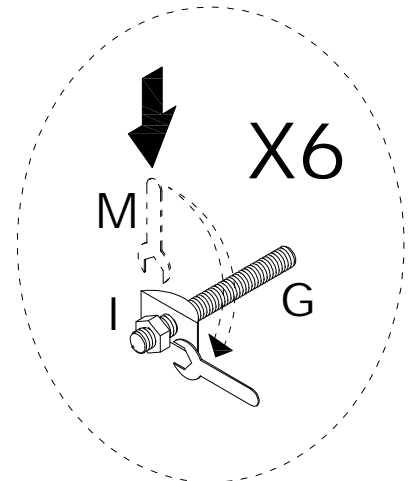
24



I

6 pcs

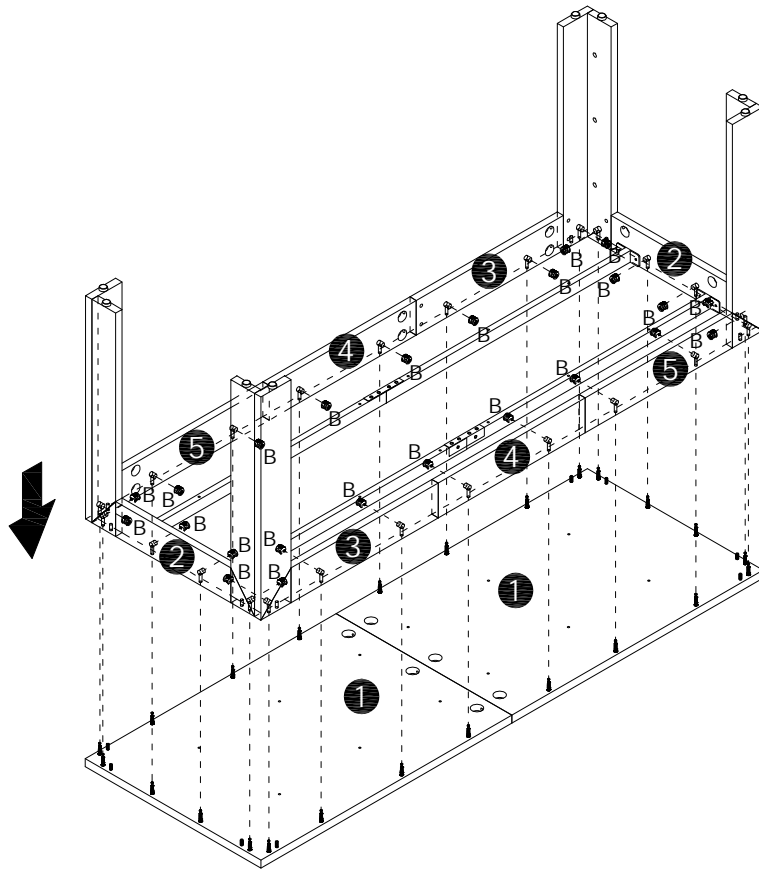
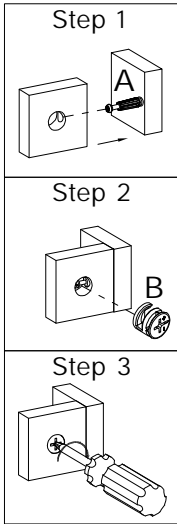

25



B

Ø15x12mm
24 pcs

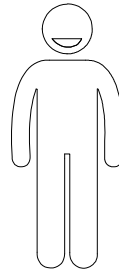
3

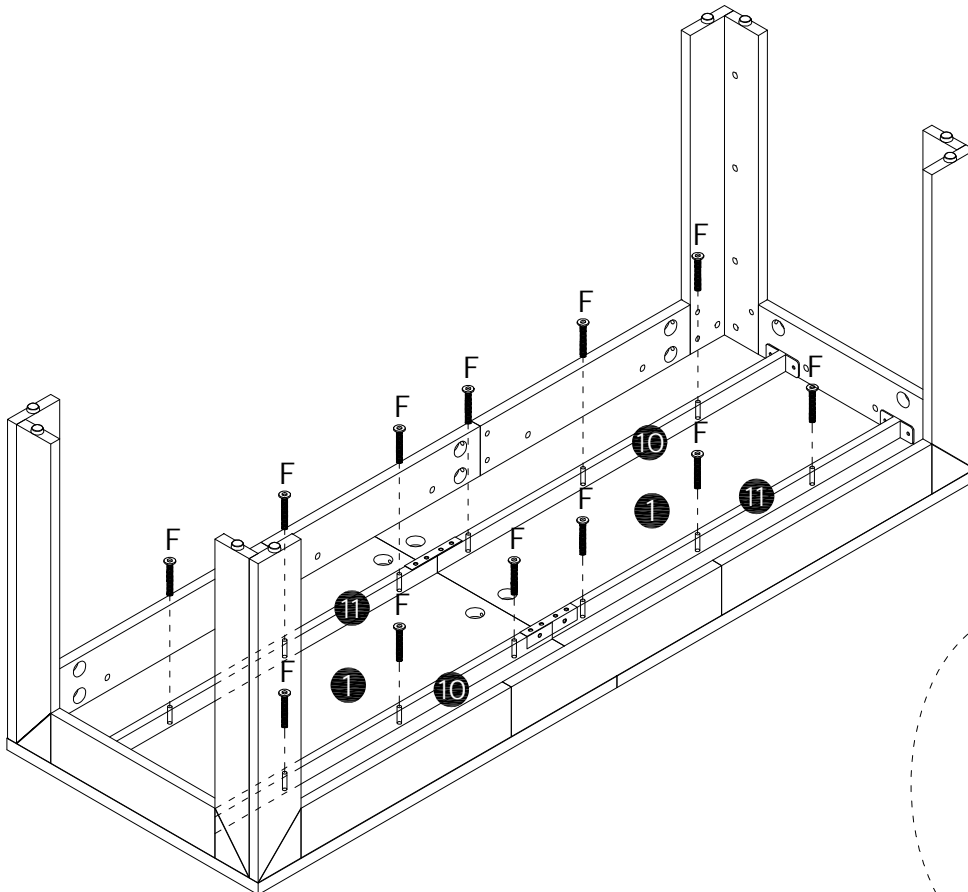

X2

26

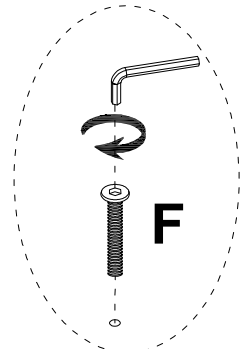

F

Ø6x55mm
12 pcs

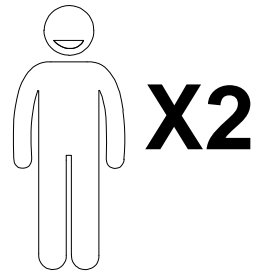
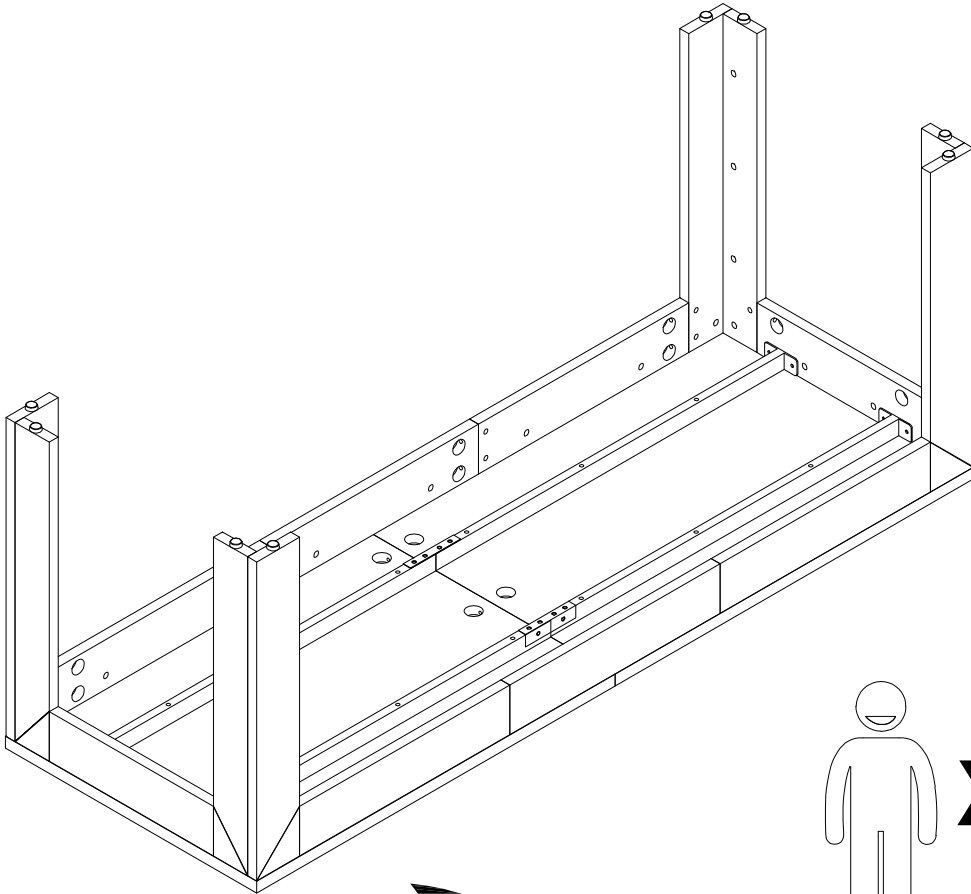

27

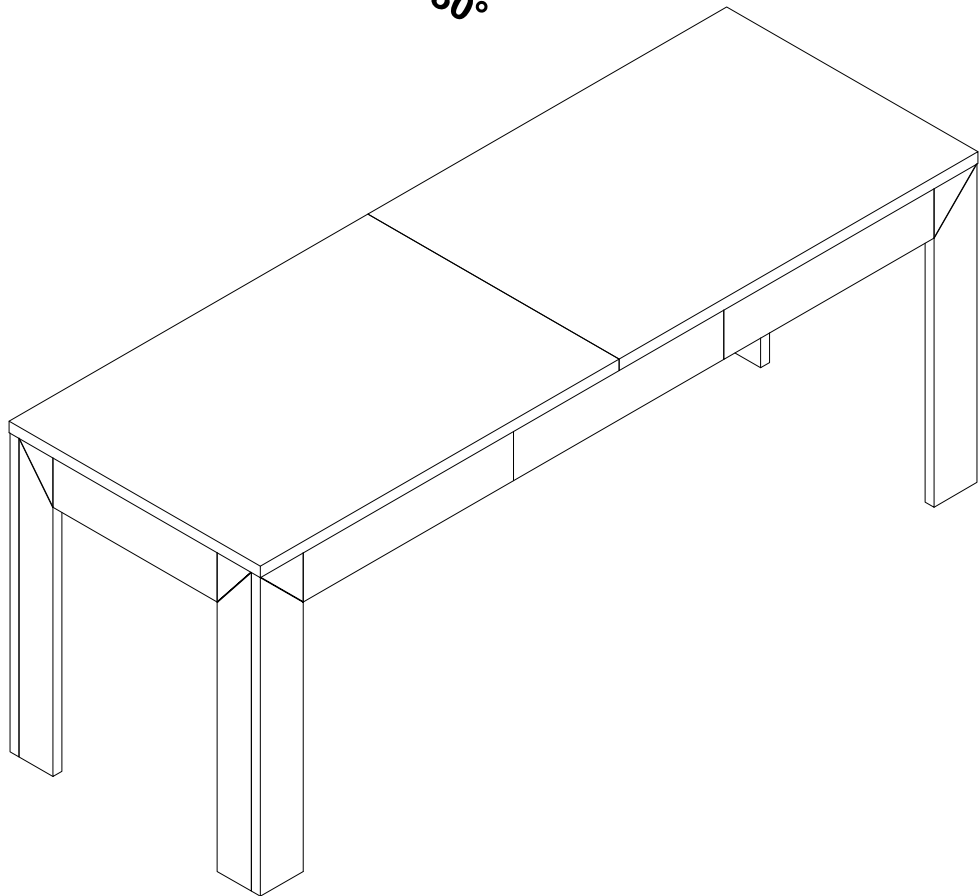

Rotate 180°



Thank you for your support !

