

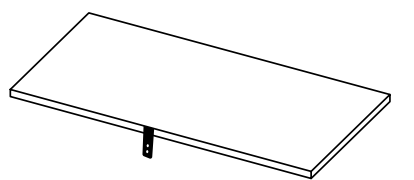

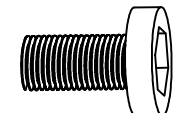

# Flip Top Wicker Ottoman

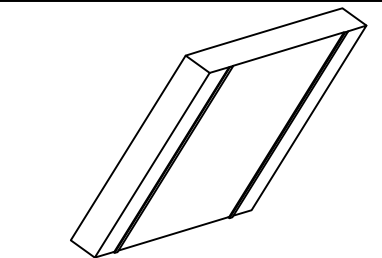
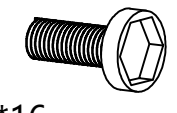
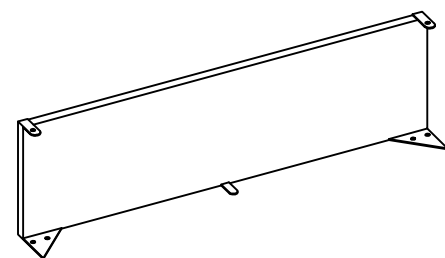

**Welcome to your assembly guide!**  
**Follow these simple steps to build a strong and stylish ottoman that adds comfort and charm to your home.**

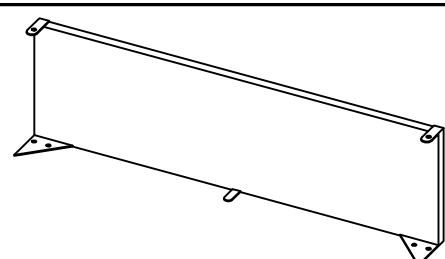
A×1	G×4+2
	M8*16 
B×1	H×16+2
	M6*16 
C×1	J×1
	
D×1	K×1
	
E×1	L×4
	
F×2	M×4
	
	N×2
	

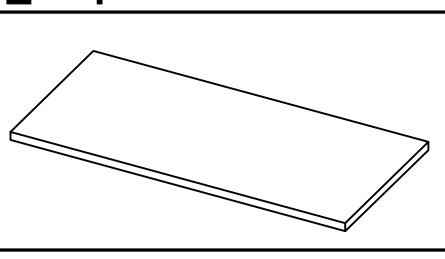
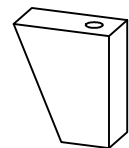
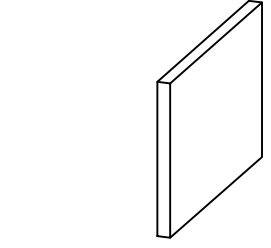
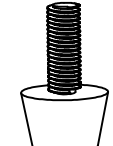
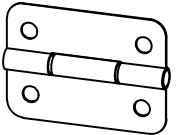
# 1

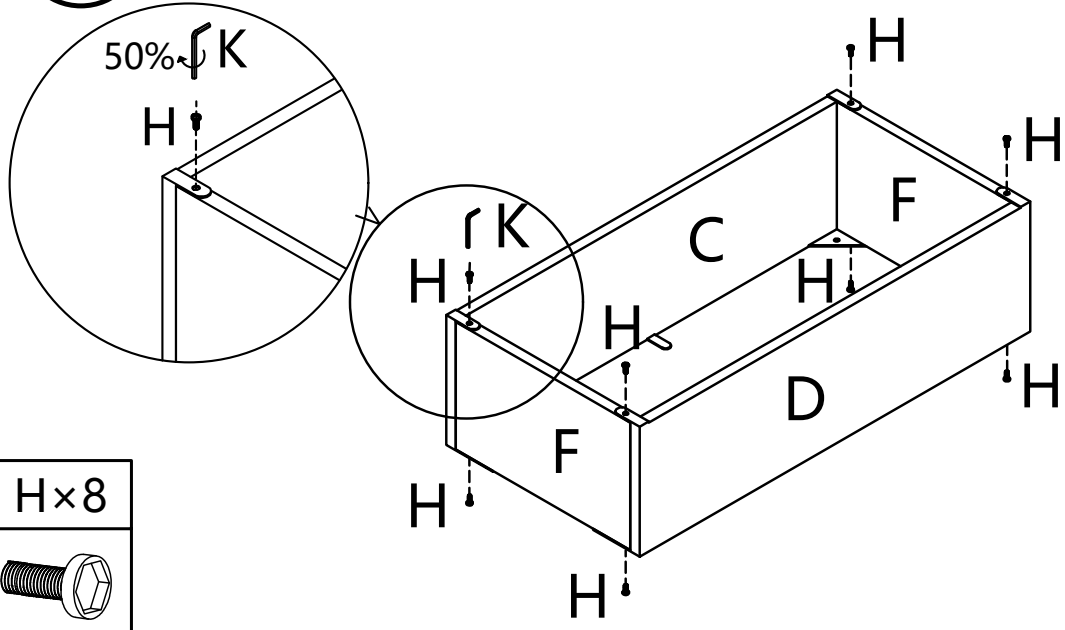

Connect (C) and (D) to the two (F) panels to form a strong metal frame. Twist (K) to secure all four corners.  
**Tip for Easier Assembly:**  
 Twist (K) only halfway in the first three corners. Once the fourth (K) is fully tightened, go back and firmly tighten the first three.

# 2

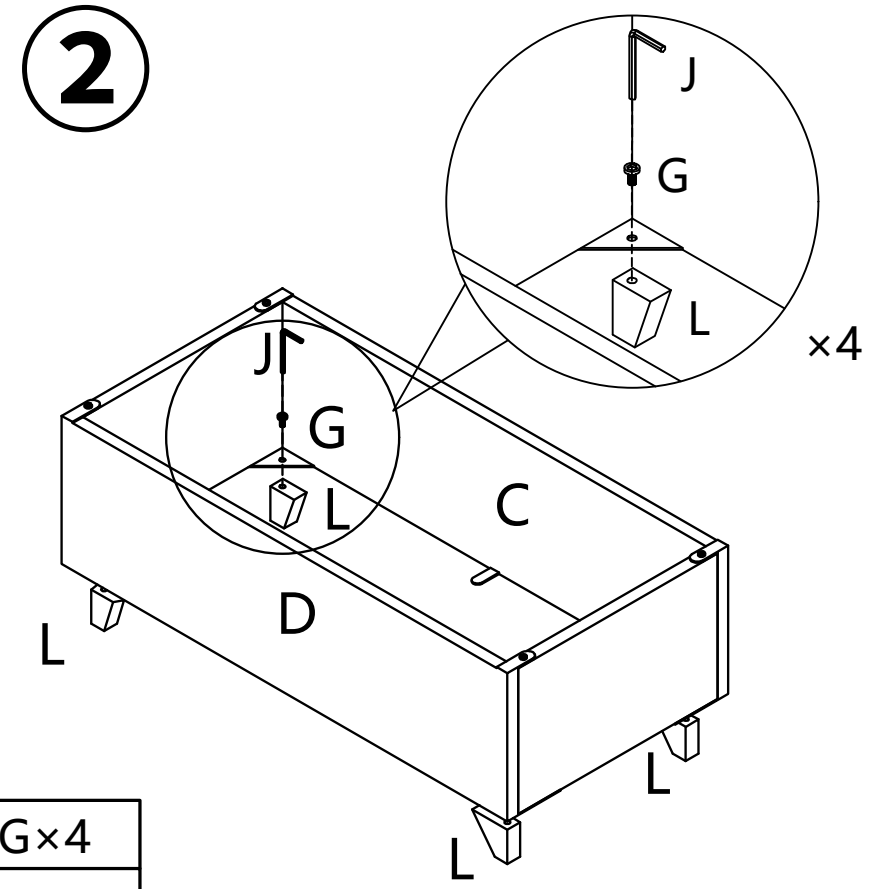

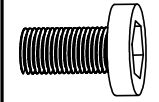
G×4  

Twist (G) to attach (L) to the frame as shown.

# 3

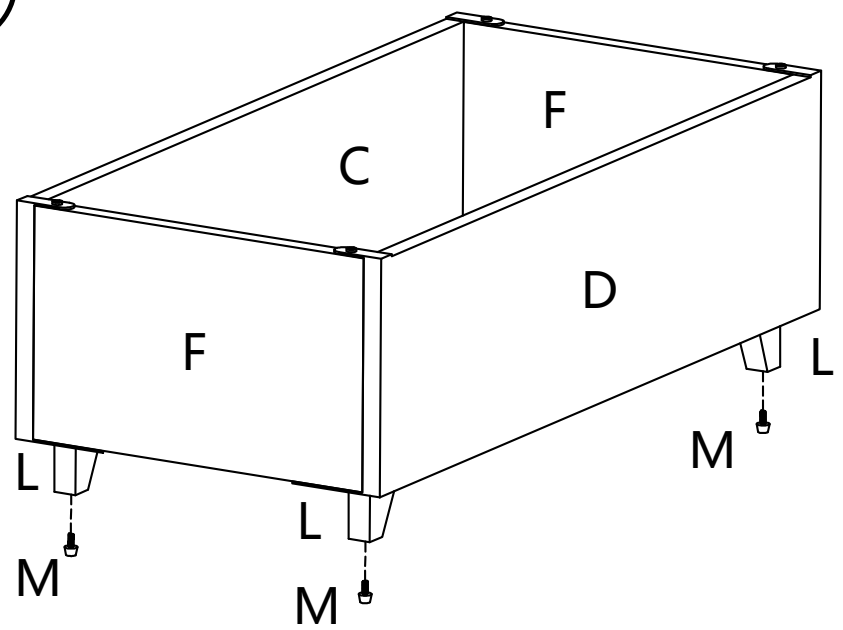

M×4  

Twist (M) into the bottom of each (L). No worries if the floor is uneven and the product feels wobbly, just try rotating part (M) to balance the gravity.



To avoid wicker tearing from improper force during assembly, twist (G) using (J) from inside the ottoman as shown. If you notice minor splits or tears, don't worry - you could use a glue gun or wood glue to repair them without affecting use.

4

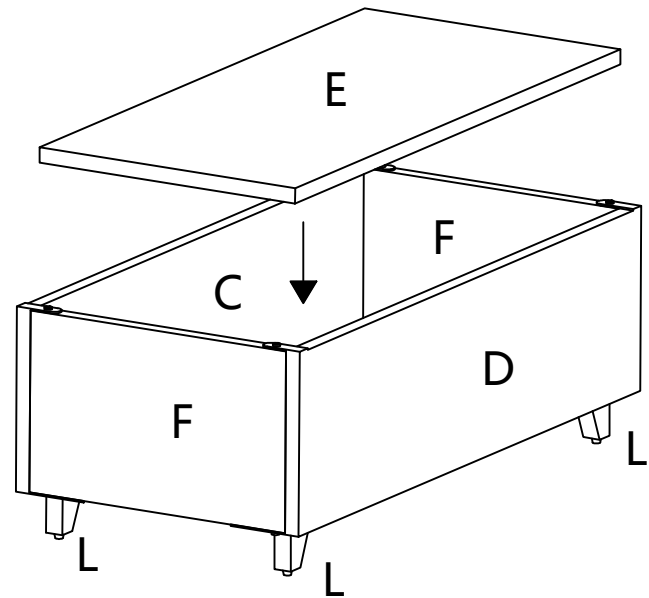

Place the bottom board (E) inside to form a sturdy base.

5

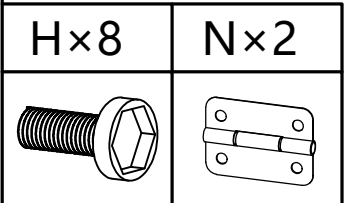
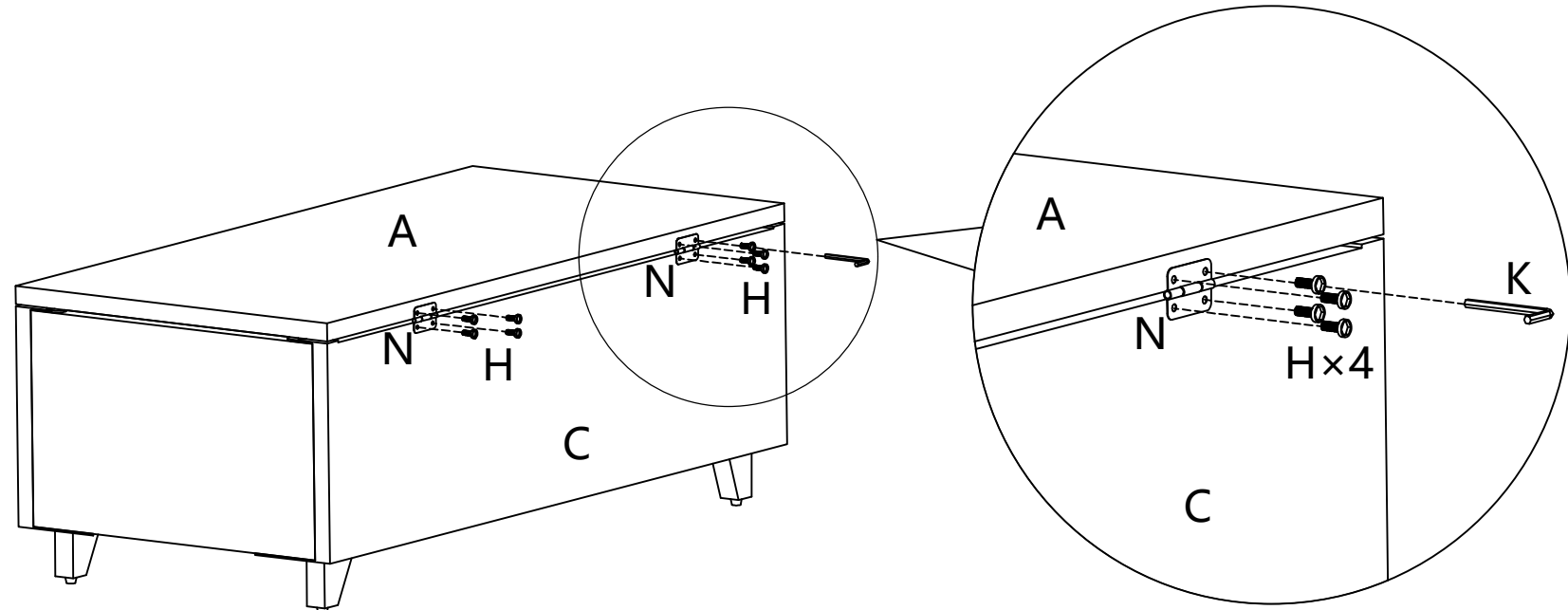

Place (A) on top of the frame.  
Twist (H) to secure hinges (N) into (A) and (C), thereby connecting them.

6

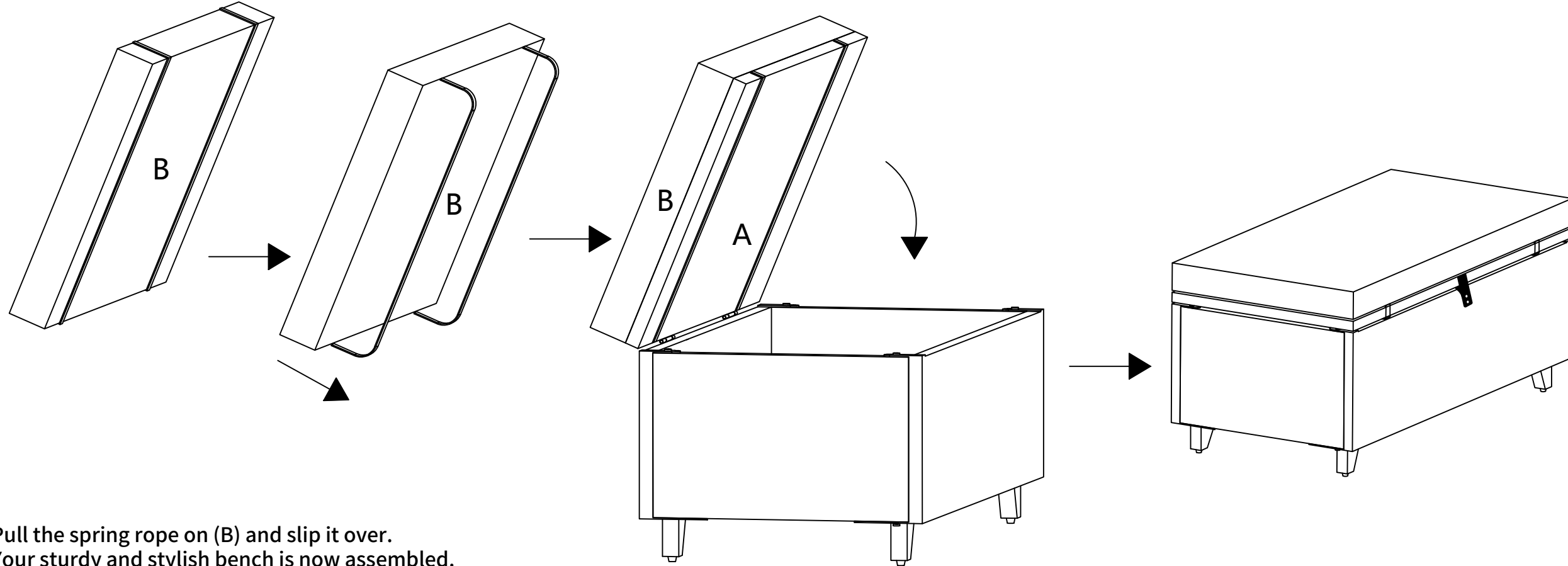

Pull the spring rope on (B) and slip it over.  
Your sturdy and stylish bench is now assembled.