

ASSEMBLY INSTRUCTIONS



Fine Furniture for every stage of life

Dining Table

ASSEMBLY INSTRUCTIONS

ASSEMBLY TIPS:

1. Remove hardware from box and sort by size.
2. Please check to see that all hardware and parts are present prior to start of assembly.
3. Please follow attached instructions in the same sequence as numbered to assure fast & easy assembly.



WARNING!

1. Don't attempt to repair or modify parts that are broken or defective. Please contact the store immediately.
2. This product is for home use only and not intended for commercial establishments.



ASSEMBLY TIME

10 MINUTES

PARTS IDENTIFICATION

B1 (BOX 1)

A TOP

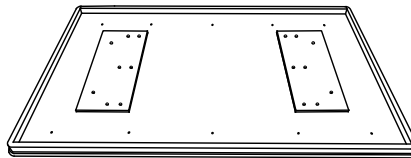

1PC

B MOUNTING PLATE



2PCS

B2 (BOX 2)

C LEG FRAME

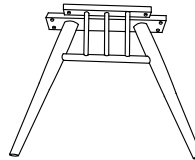

2PCS

HARDWARE IDENTIFICATION

BOX 1 - HARDWARE PACK IS LOCATED IN (B1)

1	BOLT WITH BIG WASHER (M6 x 45mm - BLK)		16PCS
2	BOLT WITH SMALL WASHER (M6 x 50mm - BLK)		10PCS
3	FLAT HEAD SCREW (M5 x 32mm - BLK)		4PCS
4	ALLEN WRENCH (M4 - GD)		1PC

NOTE:

Phillips head screw driver is required in the assembly process; however, manufacturer does not provide this item.

ASSEMBLY INSTRUCTIONS

STEP 1

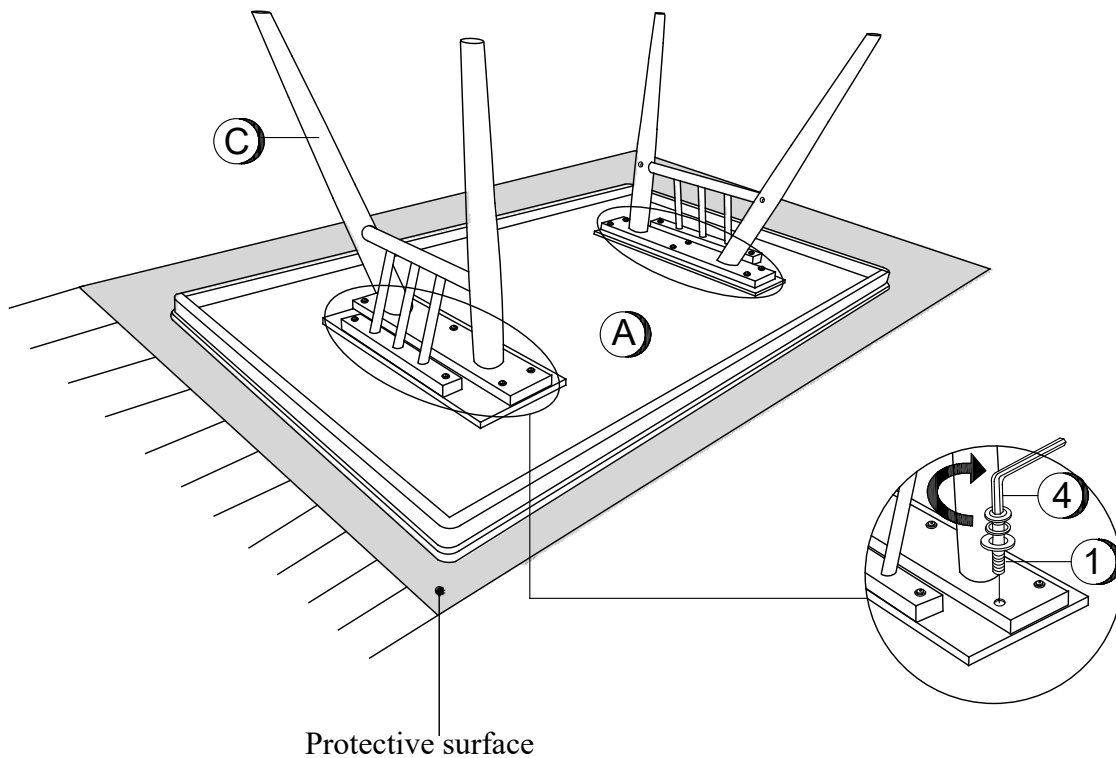

STEP 2

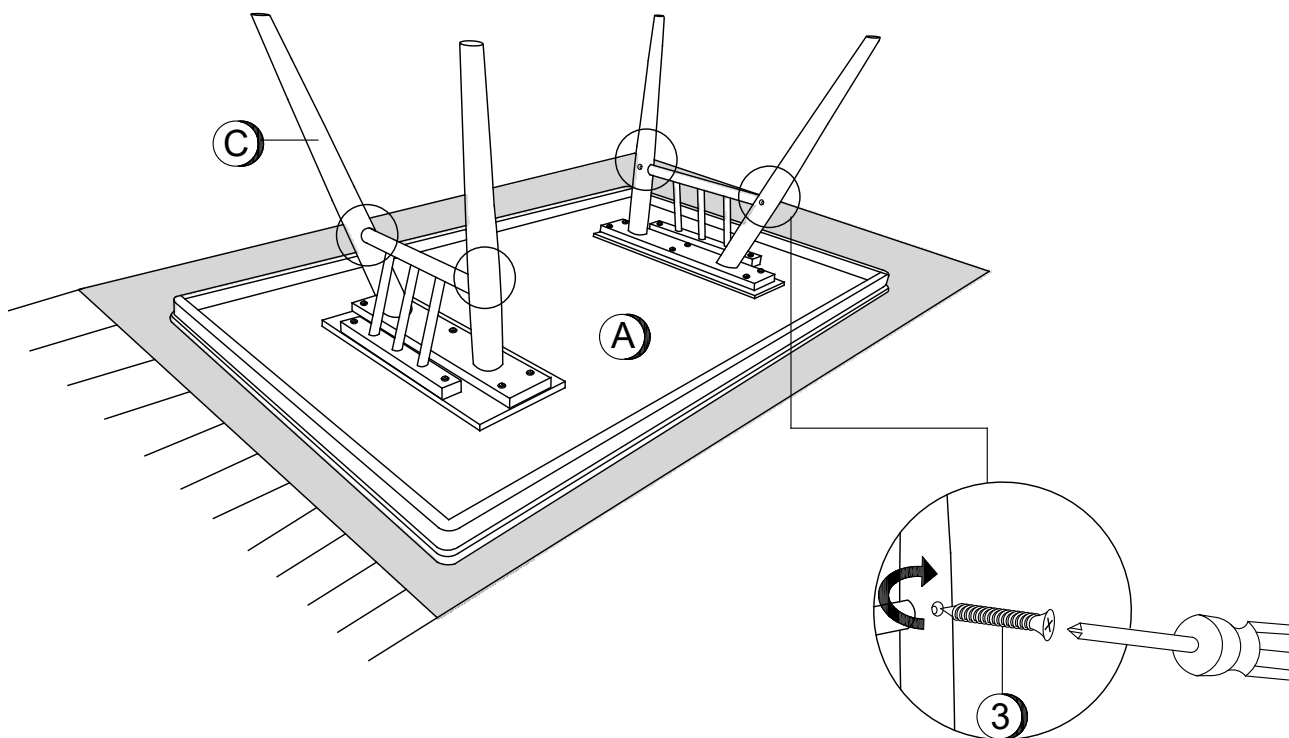

ASSEMBLY INSTRUCTIONS

STEP 3

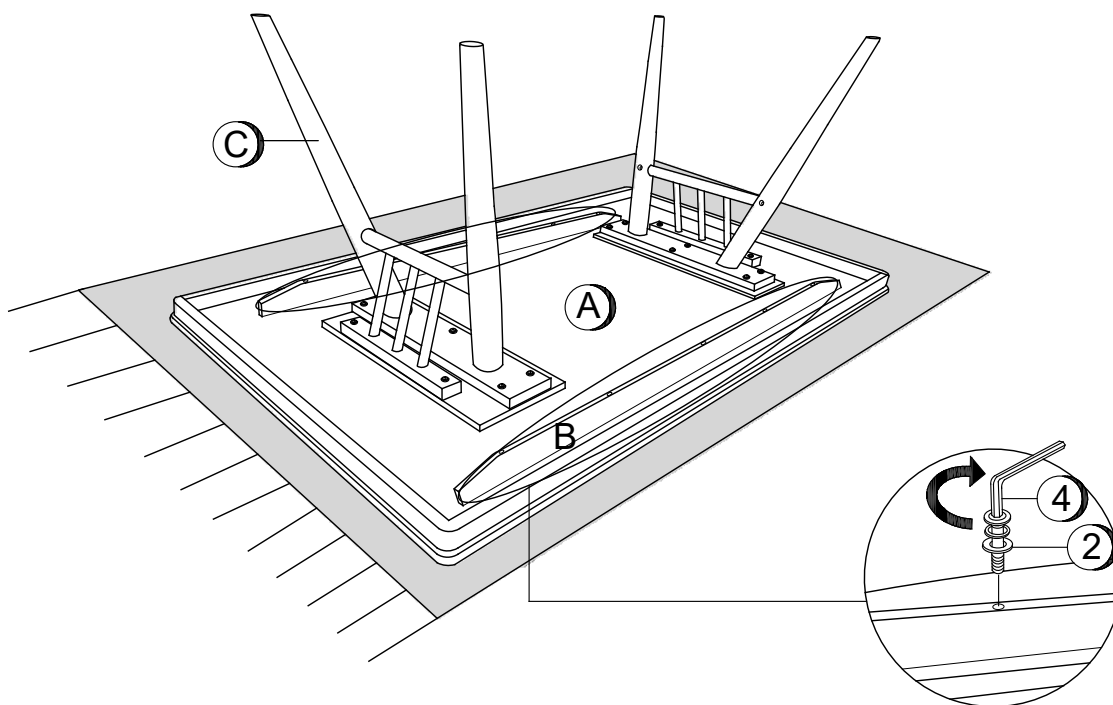

STEP 4 COMPLETE

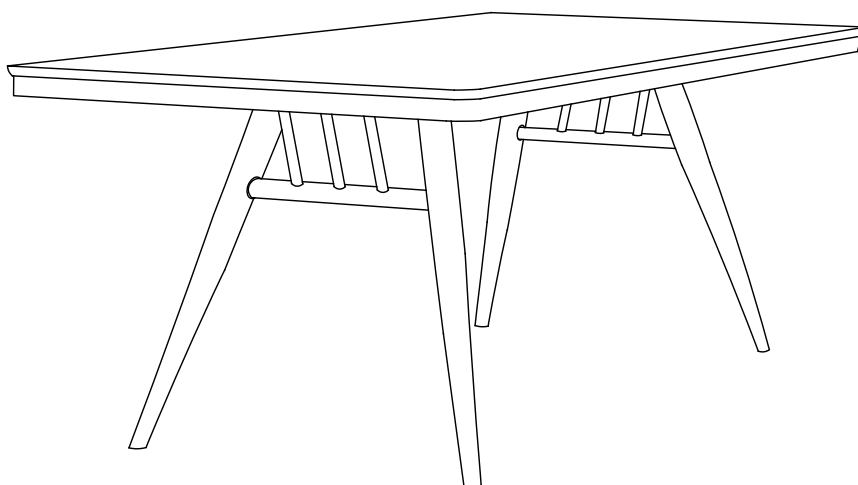

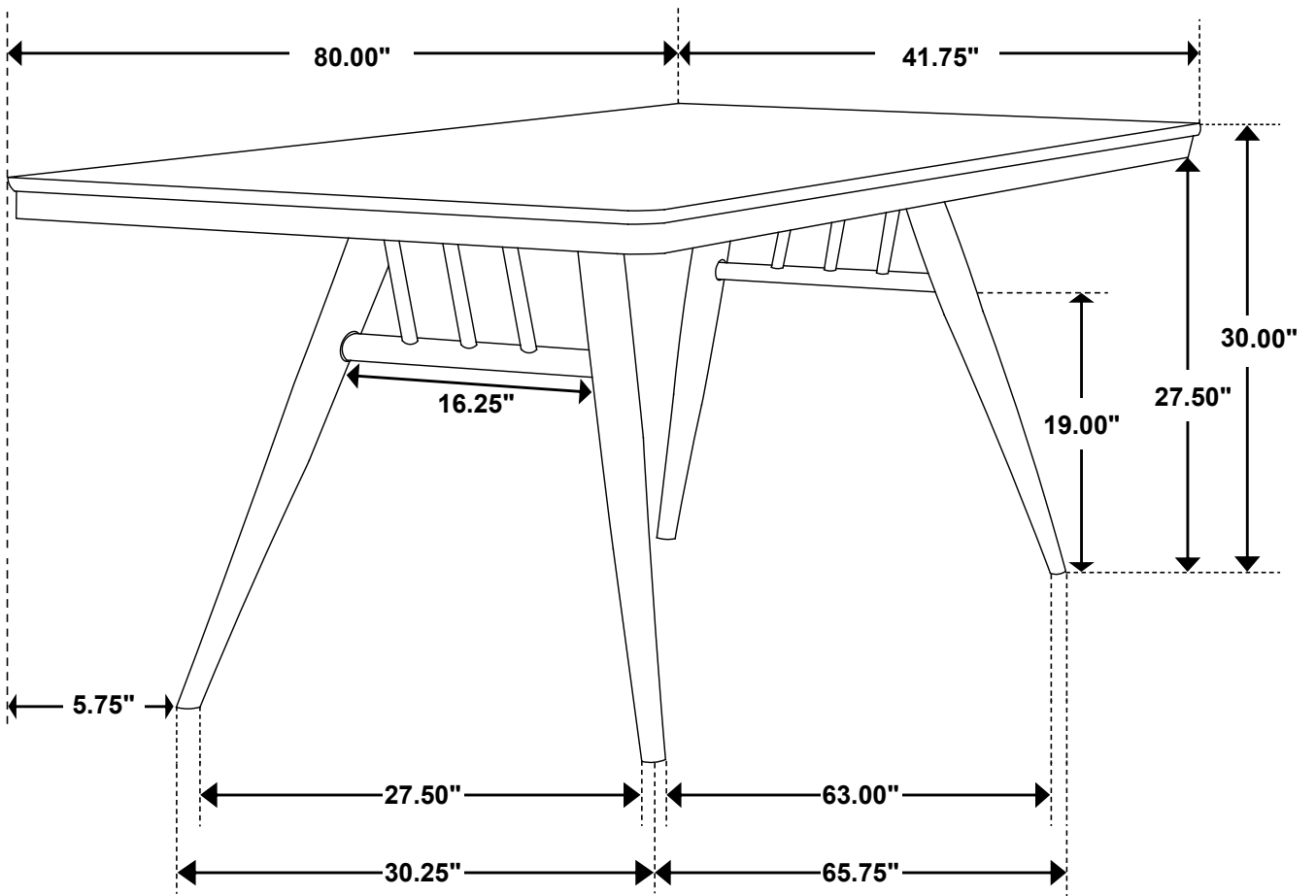

Note : Dimension tolerance $\pm 5\%$

ASSEMBLY INSTRUCTIONS



Fine Furniture for every stage of life

Dining Side Chair

ASSEMBLY INSTRUCTIONS

ASSEMBLY TIPS:

1. Remove hardware from box and sort by size.
2. Please check to see that all hardware and parts are present prior to start of assembly.
3. Please follow attached instructions in the same sequence as numbered to assure fast & easy assembly.



WARNING!

1. Don't attempt to repair or modify parts that are broken or defective. Please contact the store immediately.
2. This product is for home use only and not intended for commercial establishments.



ASSEMBLY TIME

10 MINUTES

PARTS IDENTIFICATION

A BACK FRAME

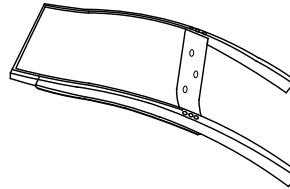

1PC

B SEAT CUSHION WITH FRAME

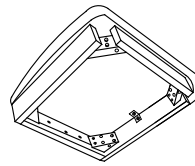

1PC

C FRONT LEG



2PCS

HARDWARE IDENTIFICATION

1 LONG BOLT WITH WASHER
(M6 x 80mm - BLK)

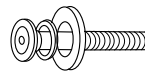

4PCS

2 MEDIUM BOLT WITH WASHER
(M6 x 60mm - BLK)

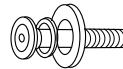

4PCS

3 SHORT BOLT WITH WASHER
(M6 x 45mm - BLK)

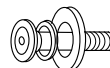

3PCS

4 ALLEN WRENCH
(M4 - GD)



1PC

NOTE:

Quantities shown are for one chair.

Phillips head screw driver is required in the assembly process; however, manufacturer does not provide this item.

ASSEMBLY INSTRUCTIONS

STEP 1

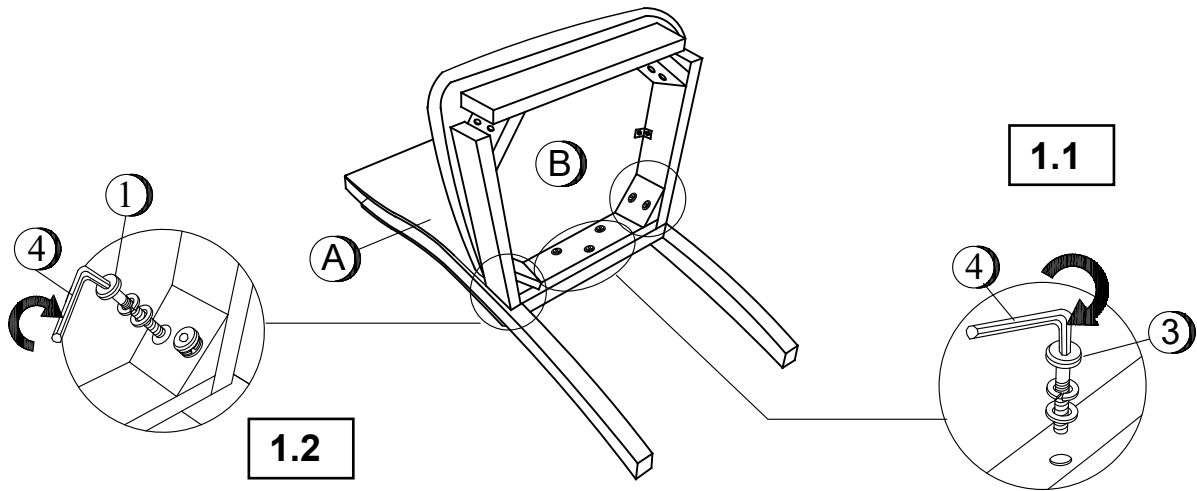

STEP 2

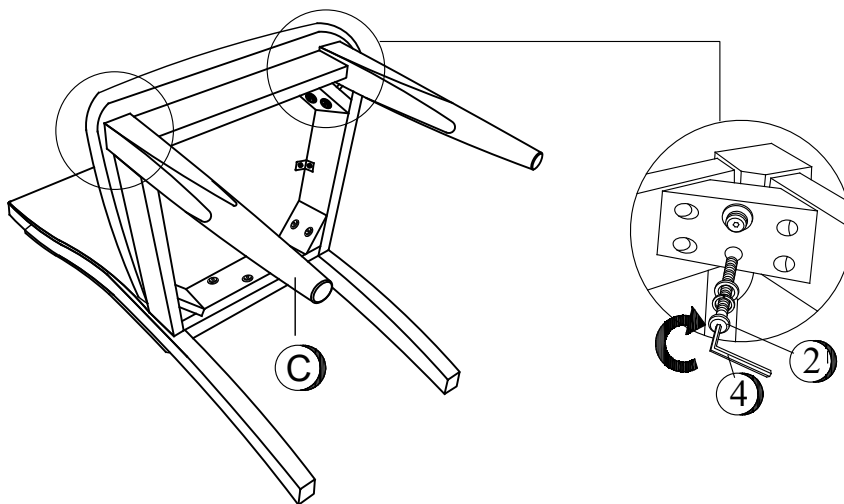

STEP 3

COMPLETE

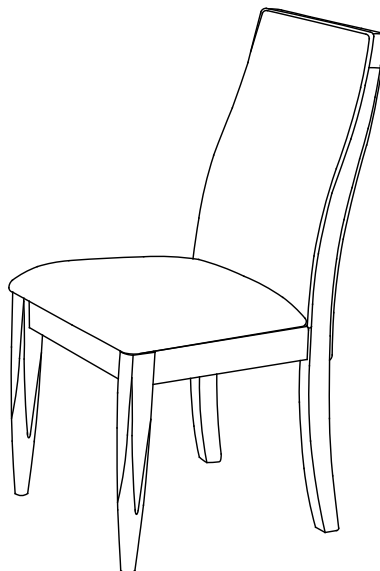

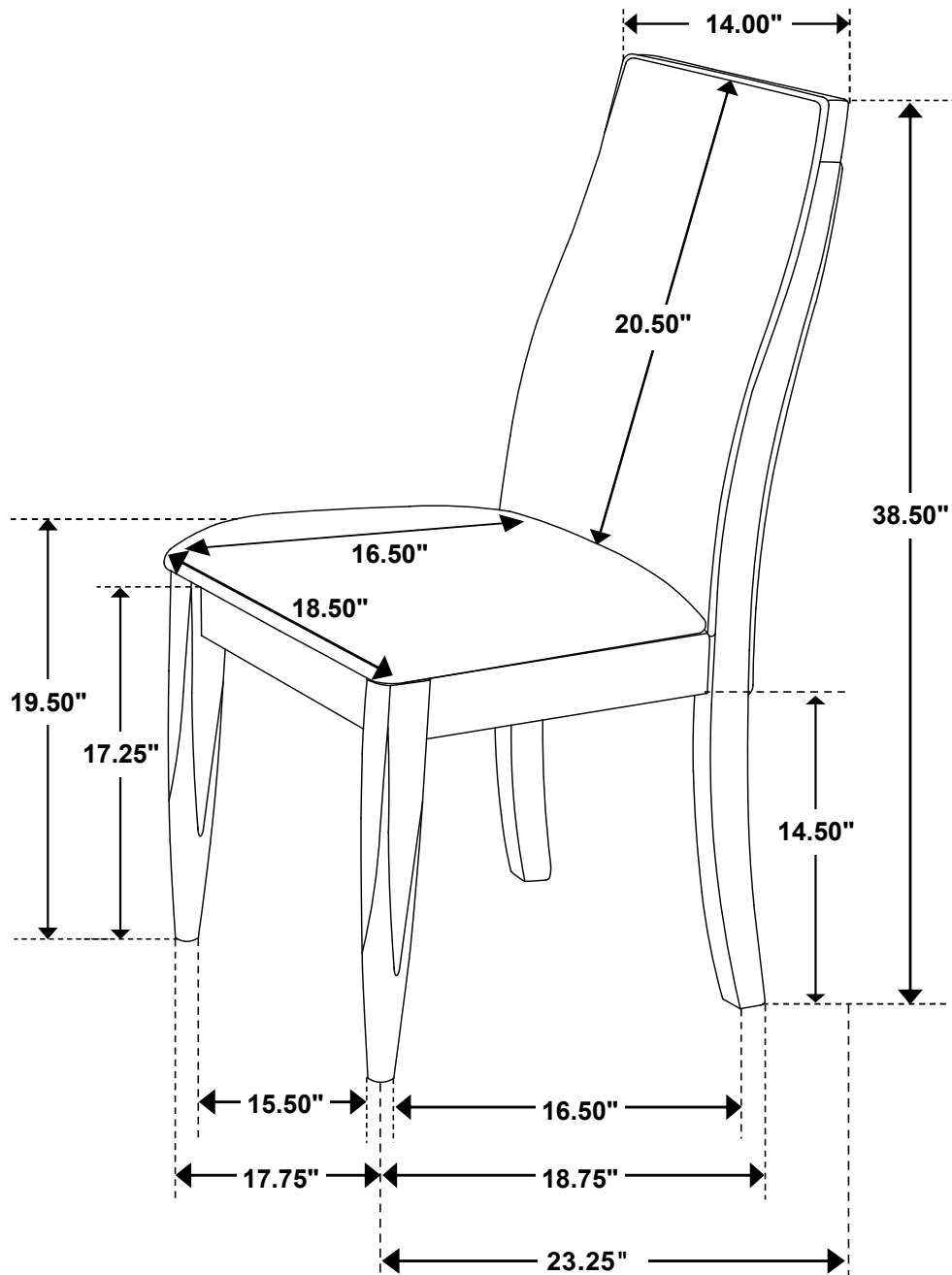

Note : Dimension tolerance $\pm 5\%$