

# NESTING TABLES

## ASSEMBLY INSTRUCTION

Pg.1/2

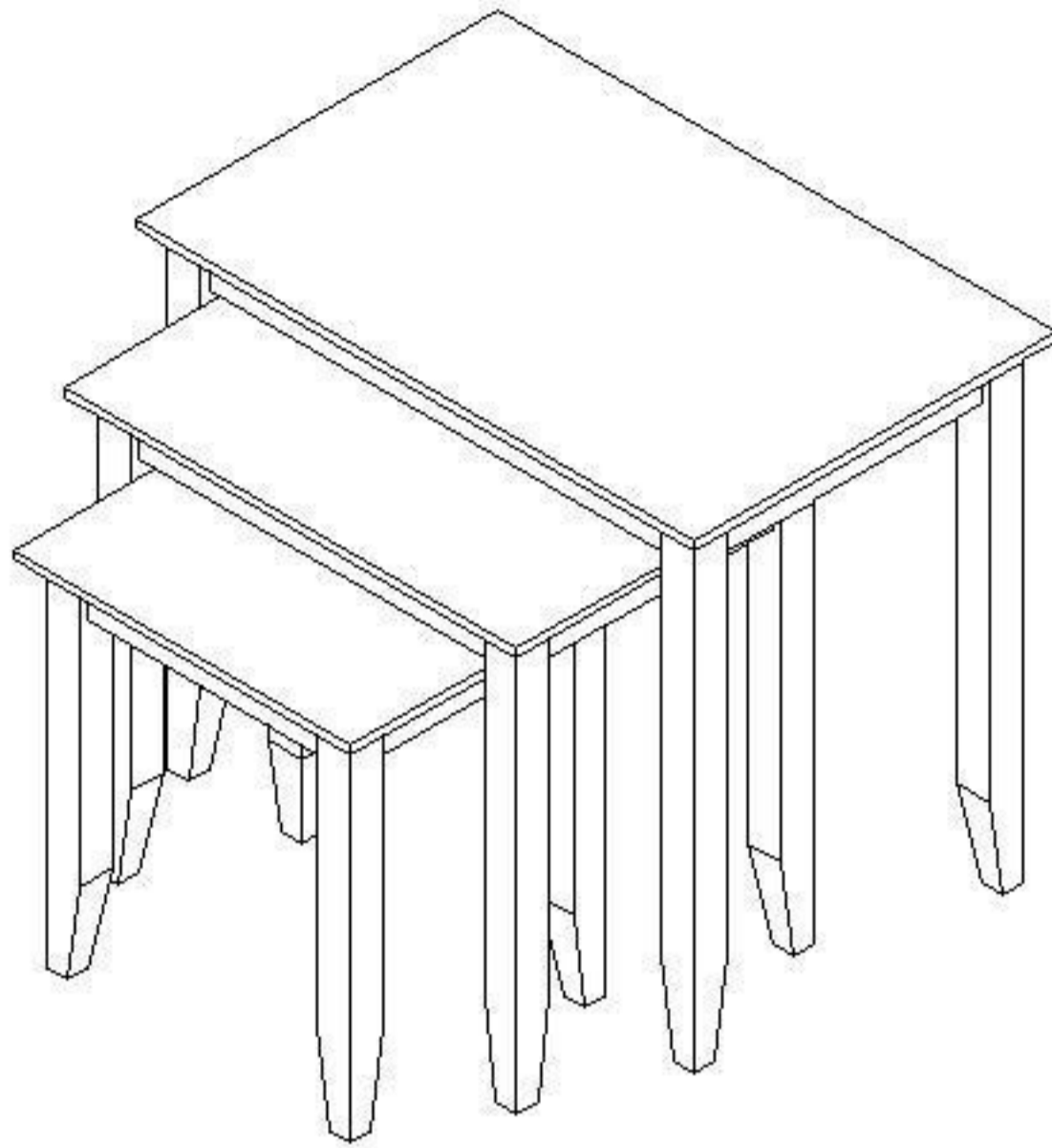

Thank you for purchasing this quality product. Be sure to check all packing material carefully for small parts that may come loose inside the carton box during shipment.

### IMPORTANT

Please go through this assembly instruction before starting assembly. Kindly follow the sequence listed to assure fast, easy and correct assembly.

### CARE & MAINTENANCE

Wipe clean with soft cloth and furniture polish.

MADE IN MALAYSIA

### PARTS LIST

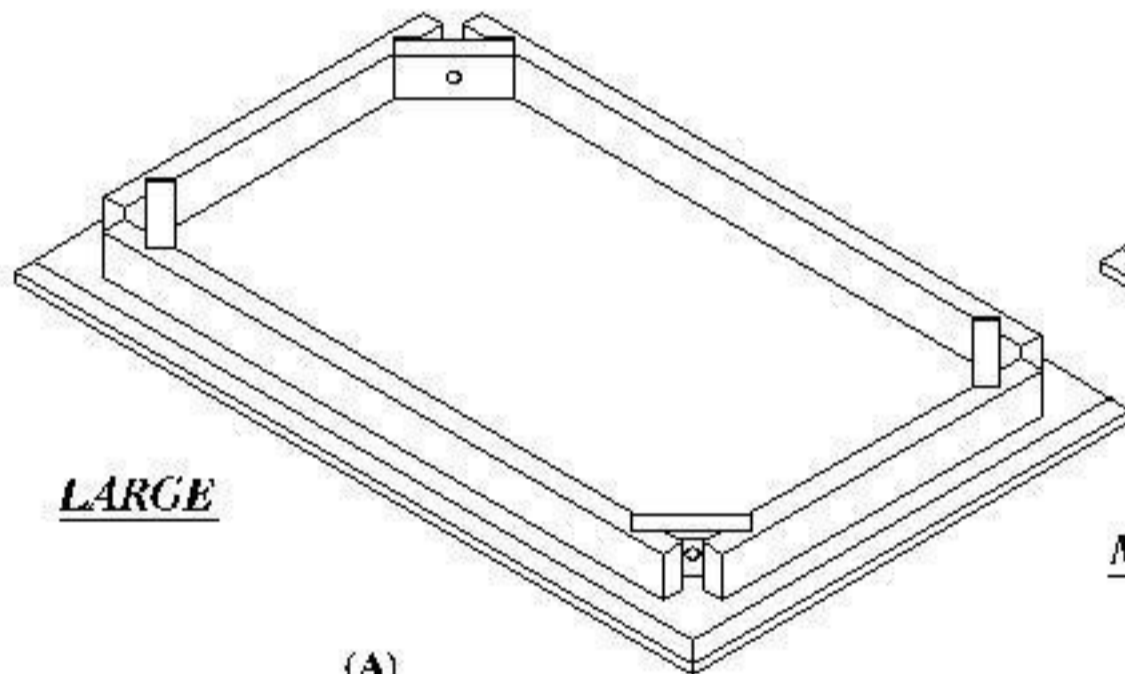

LARGE

(A)  
Table Top - 1 pc

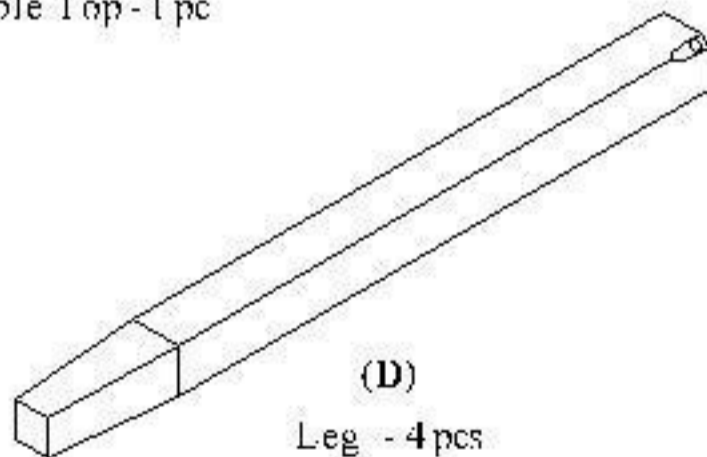

(D)  
Leg - 4 pcs

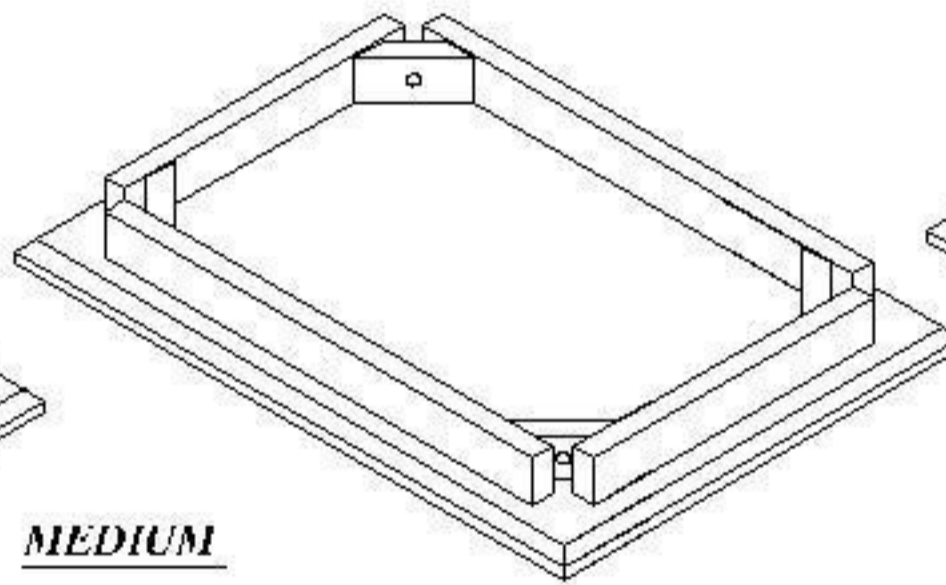

MEDIUM

(B)  
Table Top - 1 pc

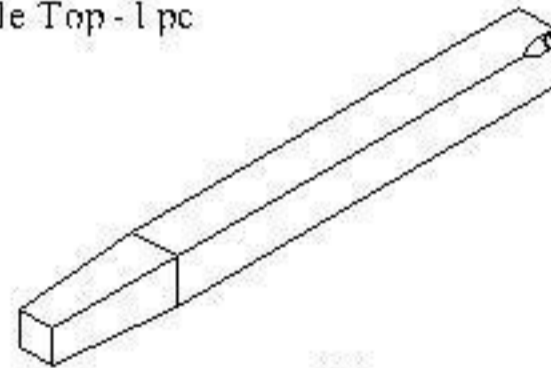

(E)  
Leg - 4 pcs

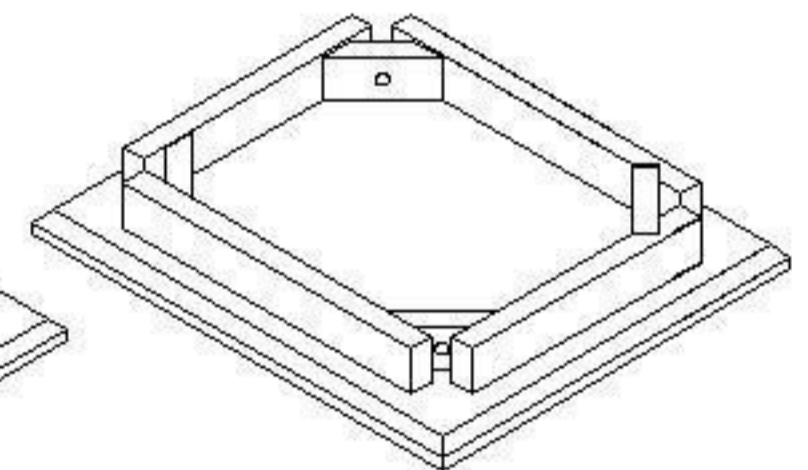

SMALL

(C)  
Table Top - 1 pc

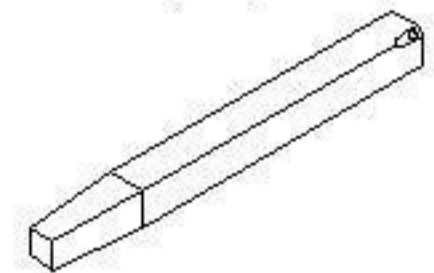

(F)  
Leg - 4 pcs

### HARDWARE LIST



(1) M6x60mm  
Hexagon Bolt - 12 pcs



(2) M6 Spring  
Washer - 12 pcs



(3) M6x16mm Flat  
Washer - 12 pcs

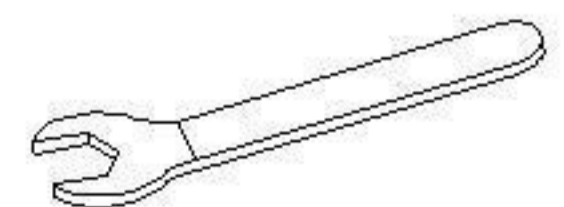

(4) 10mm Wrench - 1 pc

Note: EXTRA hardware are included

# NESTING TABLES

## ASSEMBLY INSTRUCTION

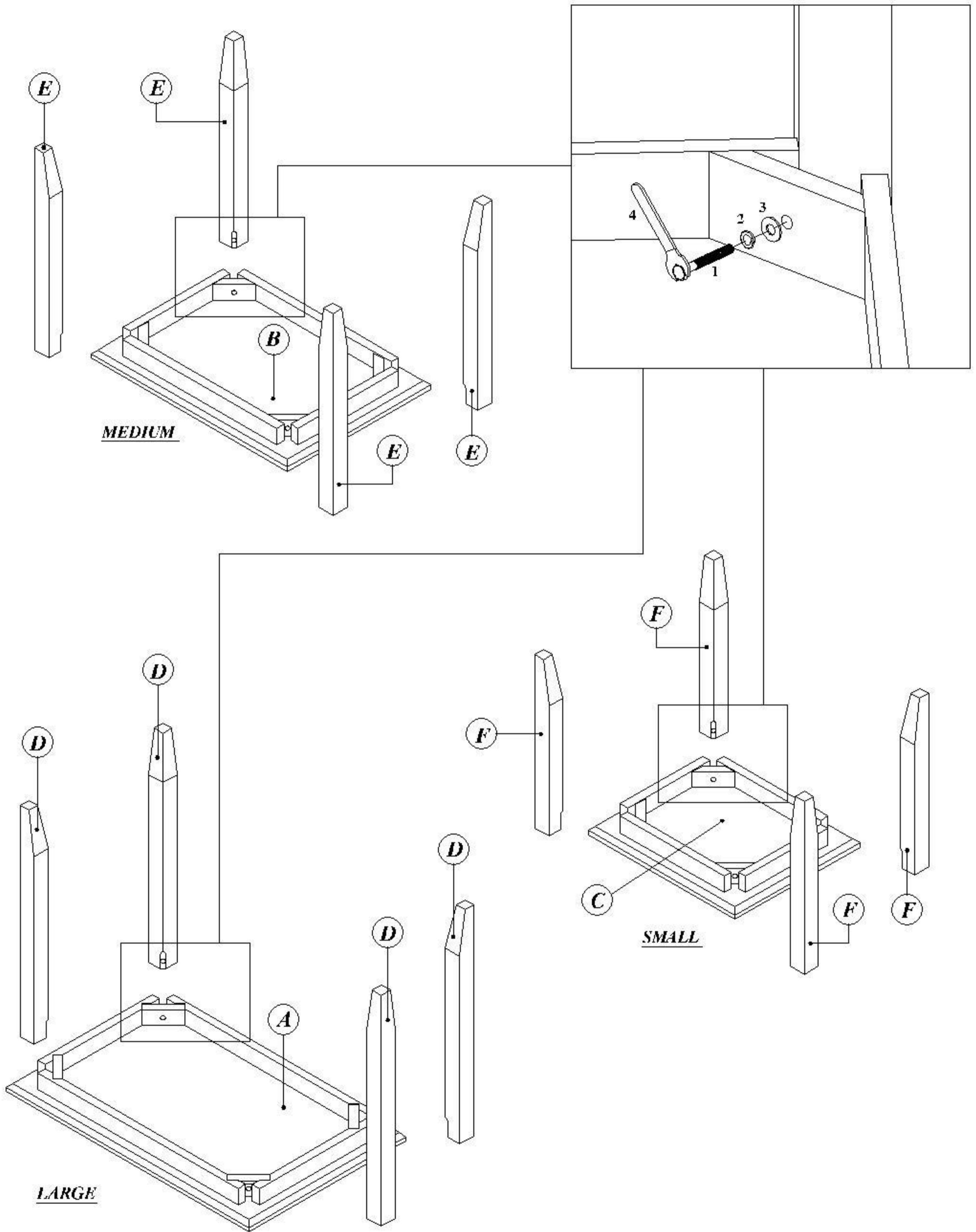

# 1

- (i) Carefully place the **TABLE TOPS (A,B,C)** on a flat safe surface.  
**NOTE** : Please find a suitable surface to avoid damaging the parts.
- (ii) Attach **LEGS (D,E,F)** to the **TABLE TOPS (A,B,C)** using Hexagon Bolts (1) together with Spring Washer (2) & Flat Washer (3).
- (iii) Fully tighten Hexagon Bolts (1) with 10mm Wrench (4).