

IMPORTANT - READ CAREFULLY - RETAIN
FOR FUTURE REFERENCE

Midsleeper

Assembly Instructions

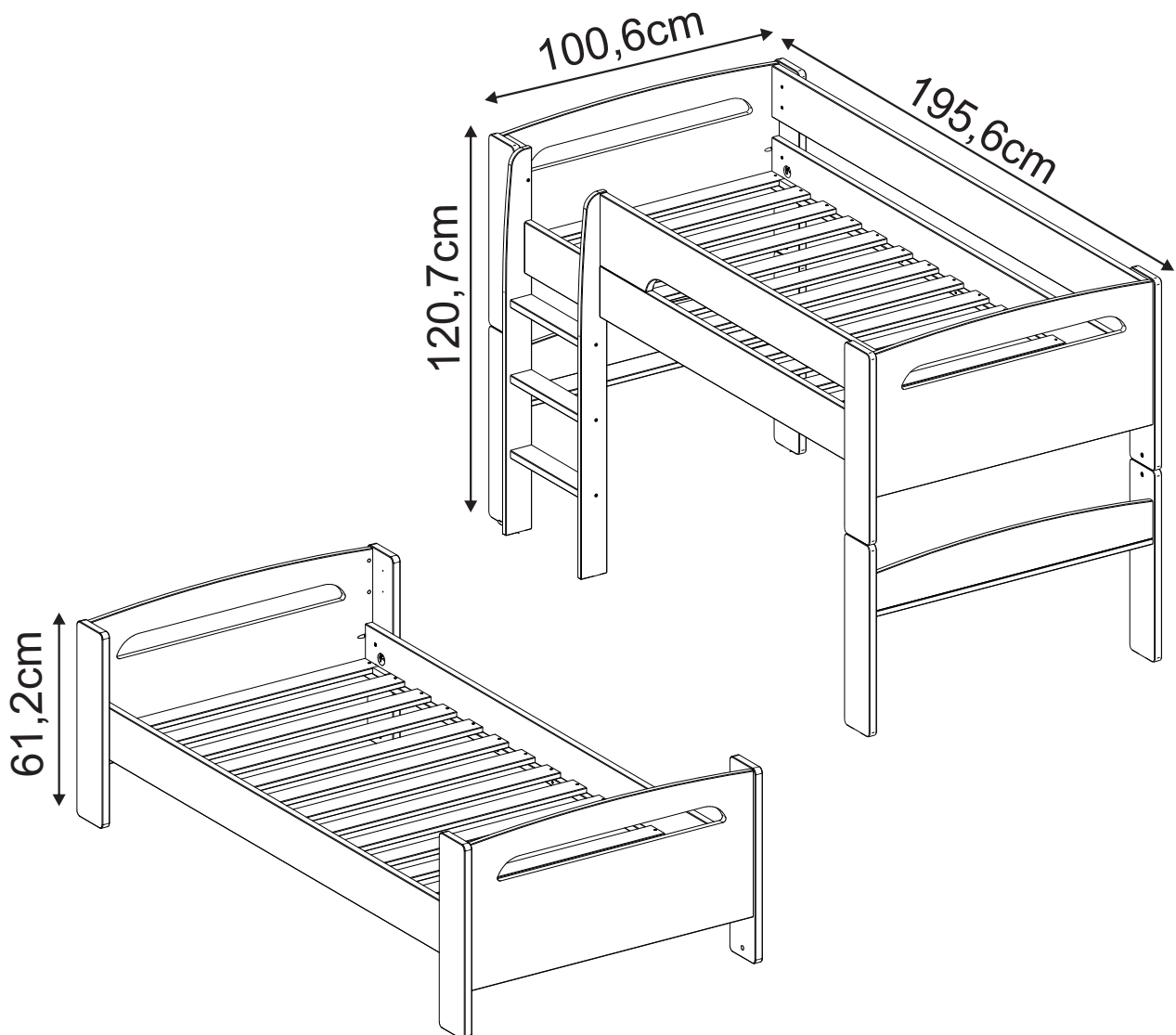

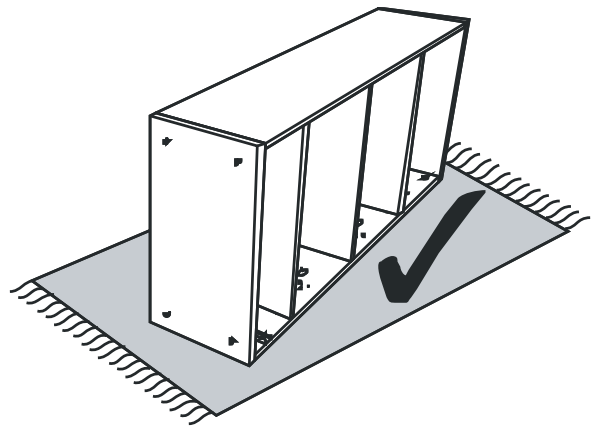
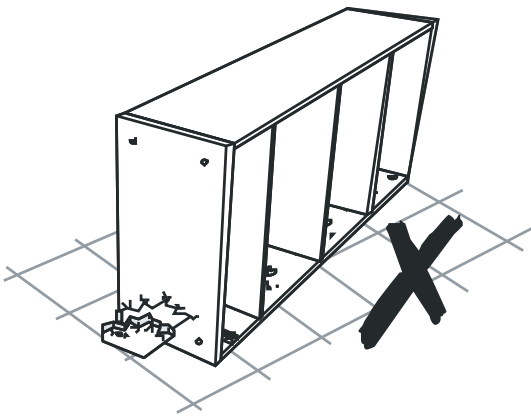
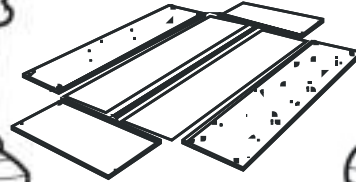
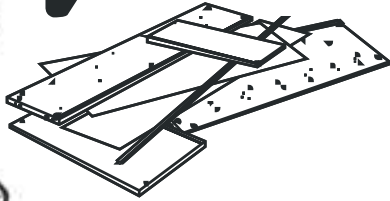
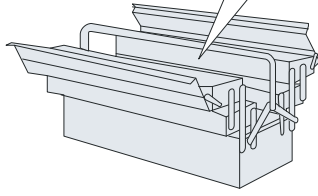
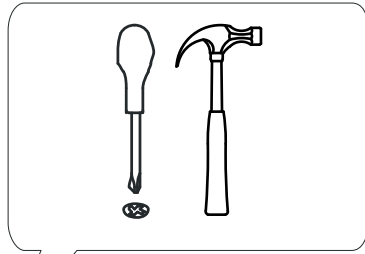

HARDWARE



Ax42
(Ø8x30)



Bx32
(Ø10x30)

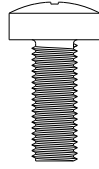

Cx8
(M6x16)

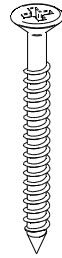

Dx30
(Ø4x35)

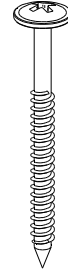

Ex36
(Ø4x40)



Fx4
(1/4x82)

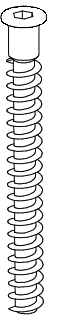

Gx8
(Ø7x60)

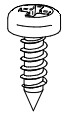

Hx4
(Ø3,5x14)

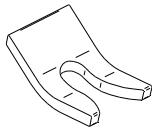

Ix4

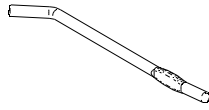

Jx1



Kx1

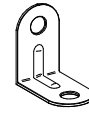

Lx2

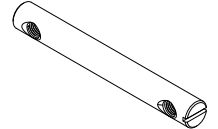

Mx4



Nx8

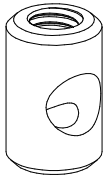

Ox8

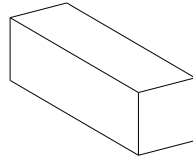

Px2



Qx8

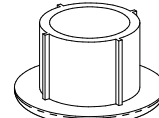

Rx8

PARTS

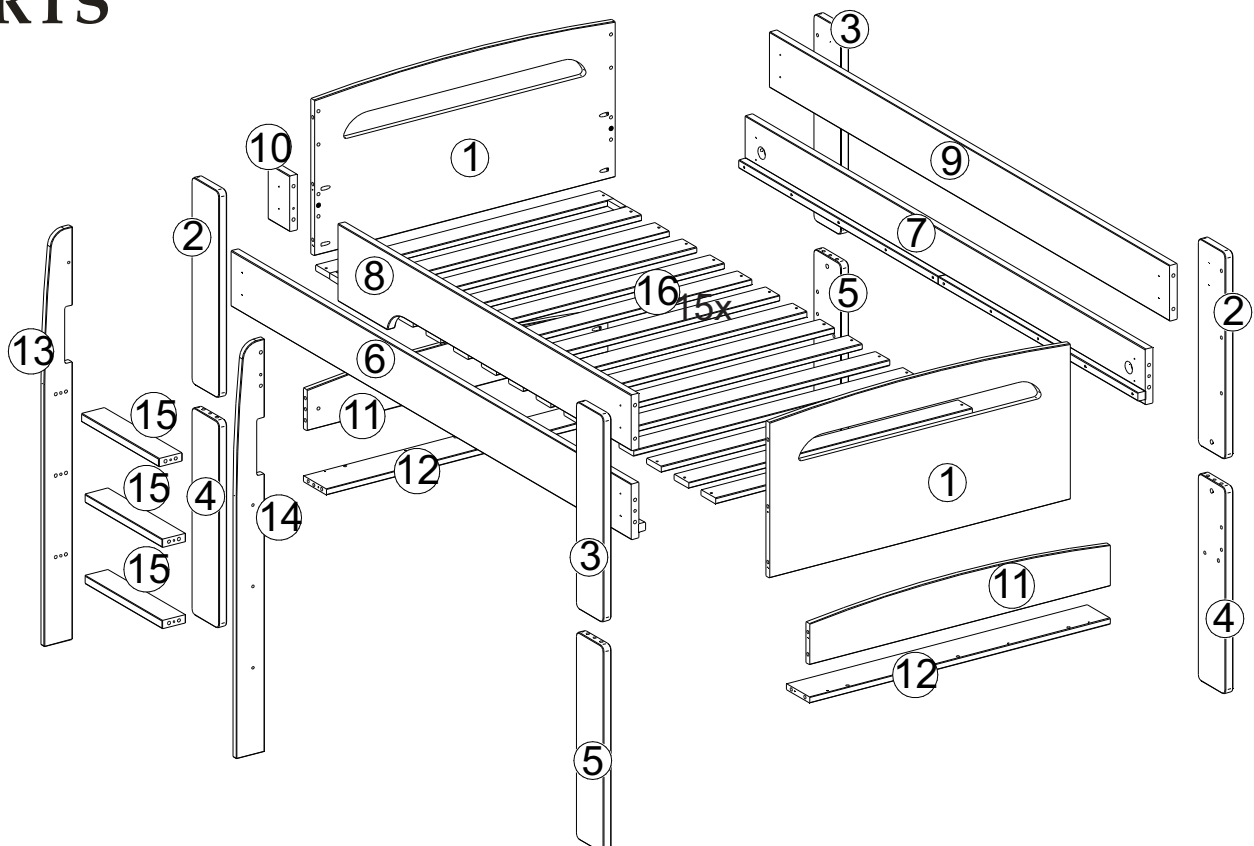

IMPORTANT INFORMATION FOR USE AS A MIDSLEEPER

WARNING-High Beds and the upper bed of bunk beds are not suitable for children under six years due to the risk of injury from falls.

WARNING-Bunk beds and high beds can present a serious risk of injury from strangulation if not used correctly. Never attach or hang items to any part of the bunk bed that are not designed to be used with the bed, for example, but not limited to ropes, strings, cords, hooks, belts and bags.

WARNING-Children can become trapped between the bed and the wall, a roof pitch, the ceiling, adjoining pieces of furniture (e.g. cupboards) and the like. To avoid risk of serious injury the distance between the top safety barrier and the adjoining structure shall not exceed 75mm or shall be more than 230mm.

WARNING-Do not use the bunk bed/high bed if any structural part is broken or missing.

It is recommended that you always follow the manufacturer's instructions to assemble the product.

Always follow the manufacturer's recommended mattress size, as per these instructions and the bunk bed / high bed maximum mattress height marking on the item (160mm).

This bed may not be dismantled for storage or transportation.

It is necessary to frequently ventilate the room in order to keep the humidity low and to prevent mold in and around the bed.

Please periodically check all the fixings of the item and re tighten when necessary

This item conforms to European Safety Standards -

Specification For Bunk Beds & High Beds &

- Standart

Consumer Safety Specification For Junior beds.

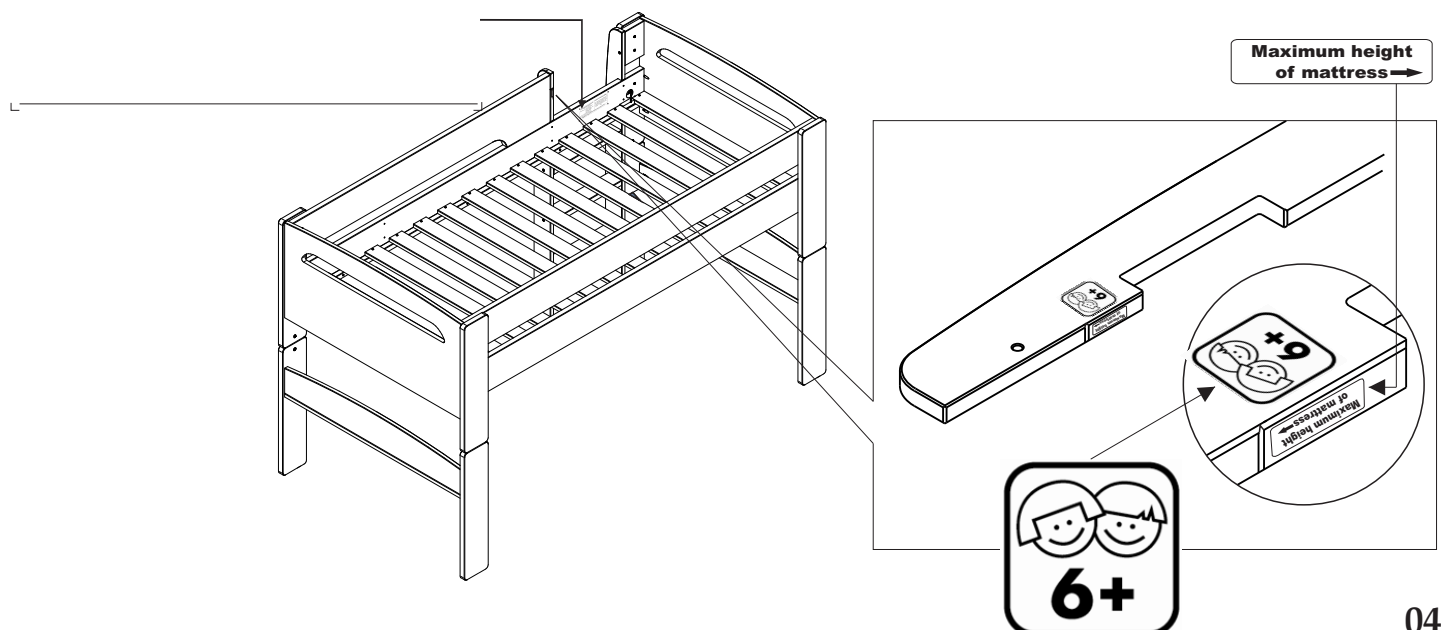

Safety Advice

Please take the time to carefully read through the whole of these instructions before you commence.

Keep these instructions for future reference.

Unpack, inspect and check off all of the contents.

Please dispose of all packaging safely.

Small component parts could choke a child if swallowed.

We strongly recommend that you keep children well away from the work area.

It would be sensible to lay a sheet or blanket on the floor where you intend to work to avoid scratching this product and to protect your floor.

This product is heavy. Take extreme care when lifting to avoid personal injury or damage to the product.

Assemble the product as close to it's intended final position in the room as possible.

Please check the contents of boxes before attempting to assemble this product. A full checklist of parts and fittings is given in page 3 of this instruction leaflet.

We strongly urge that you do not use Power Tools, such as drills or electric screwdrivers during this assembly as this could cause irreparable damage to your product and will invalidate the warranty.

HANDY HINT: If you keep the hardware in a bowl during assembly you will be less likely to lose them.

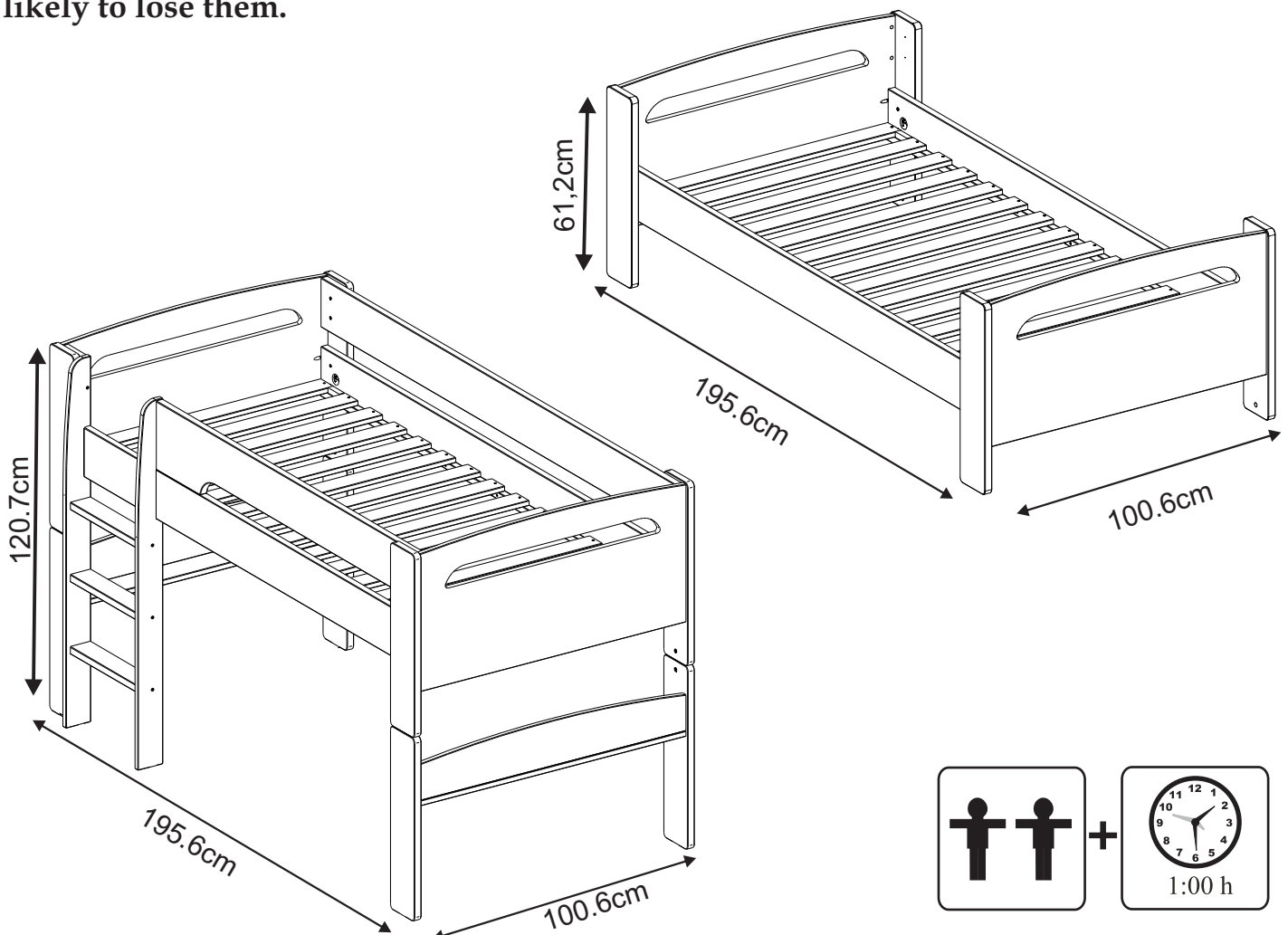

OPTIONS

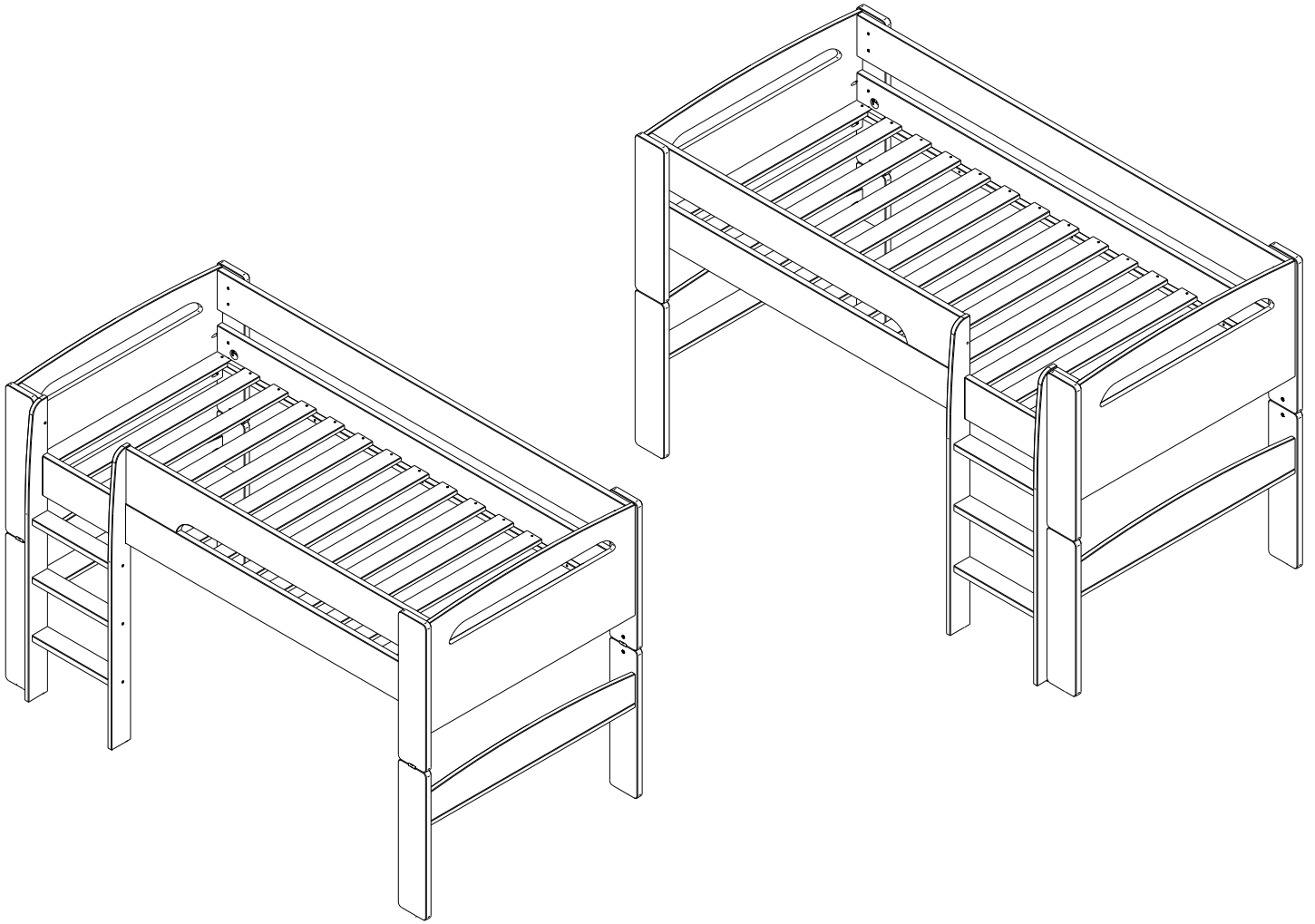

STARTS ON PAGE 19

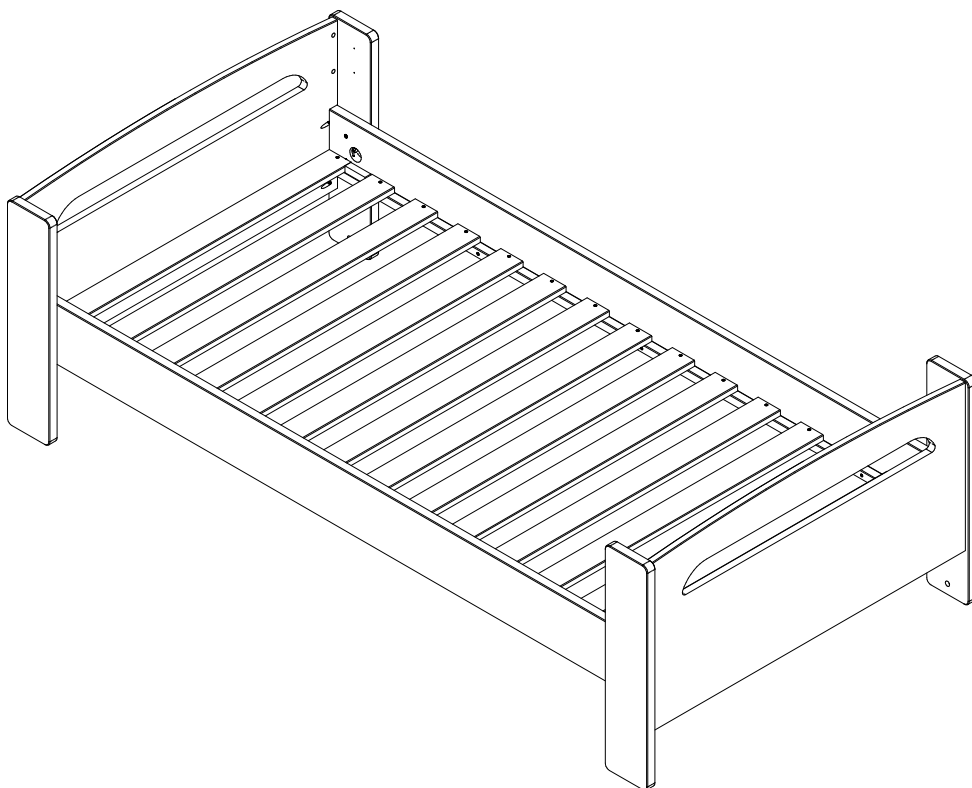

1

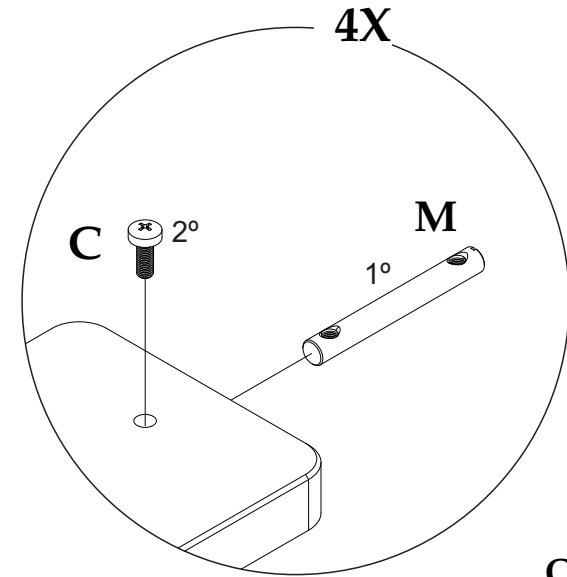

Partially tighten Part C

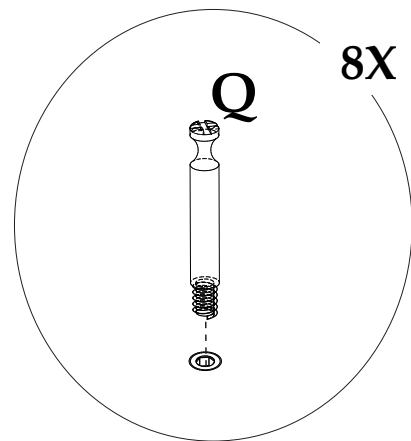
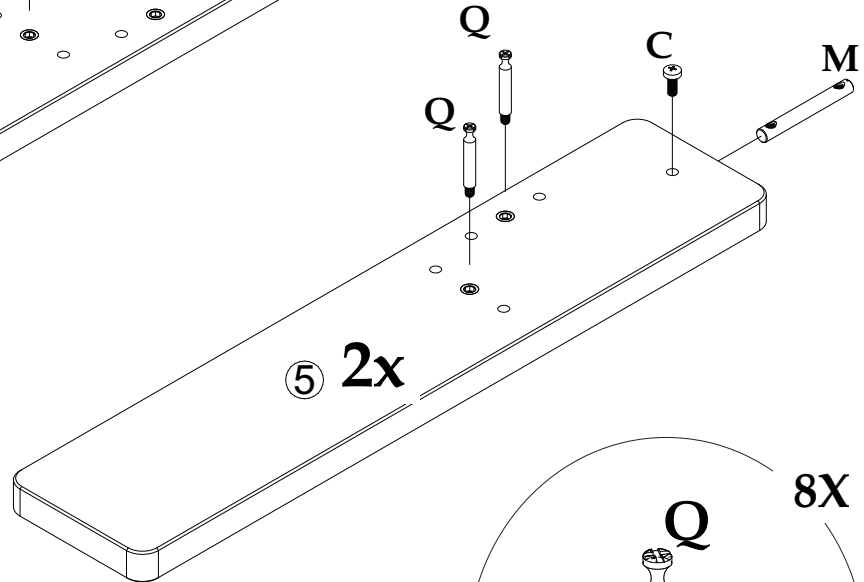
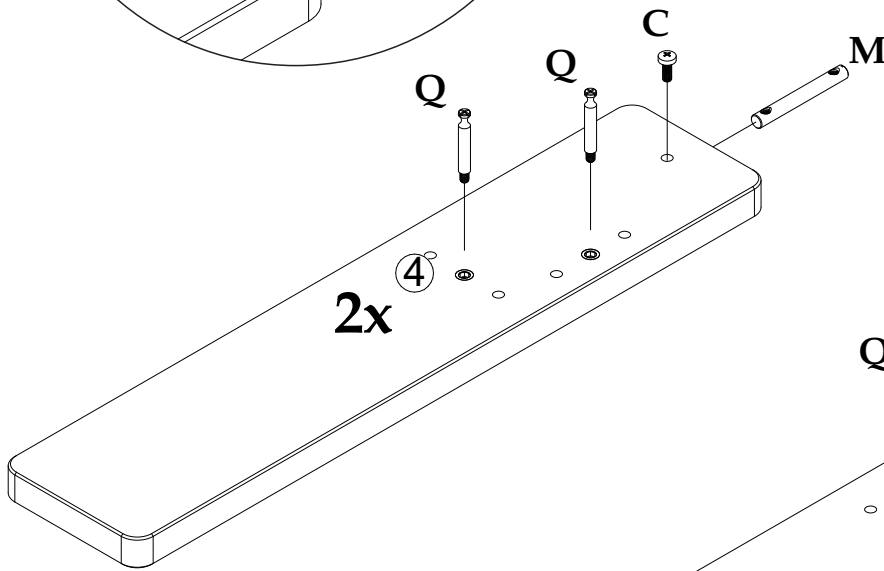
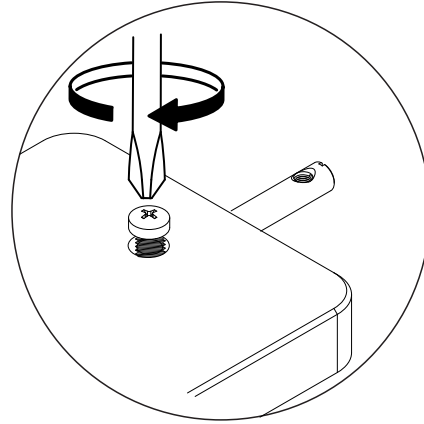

2

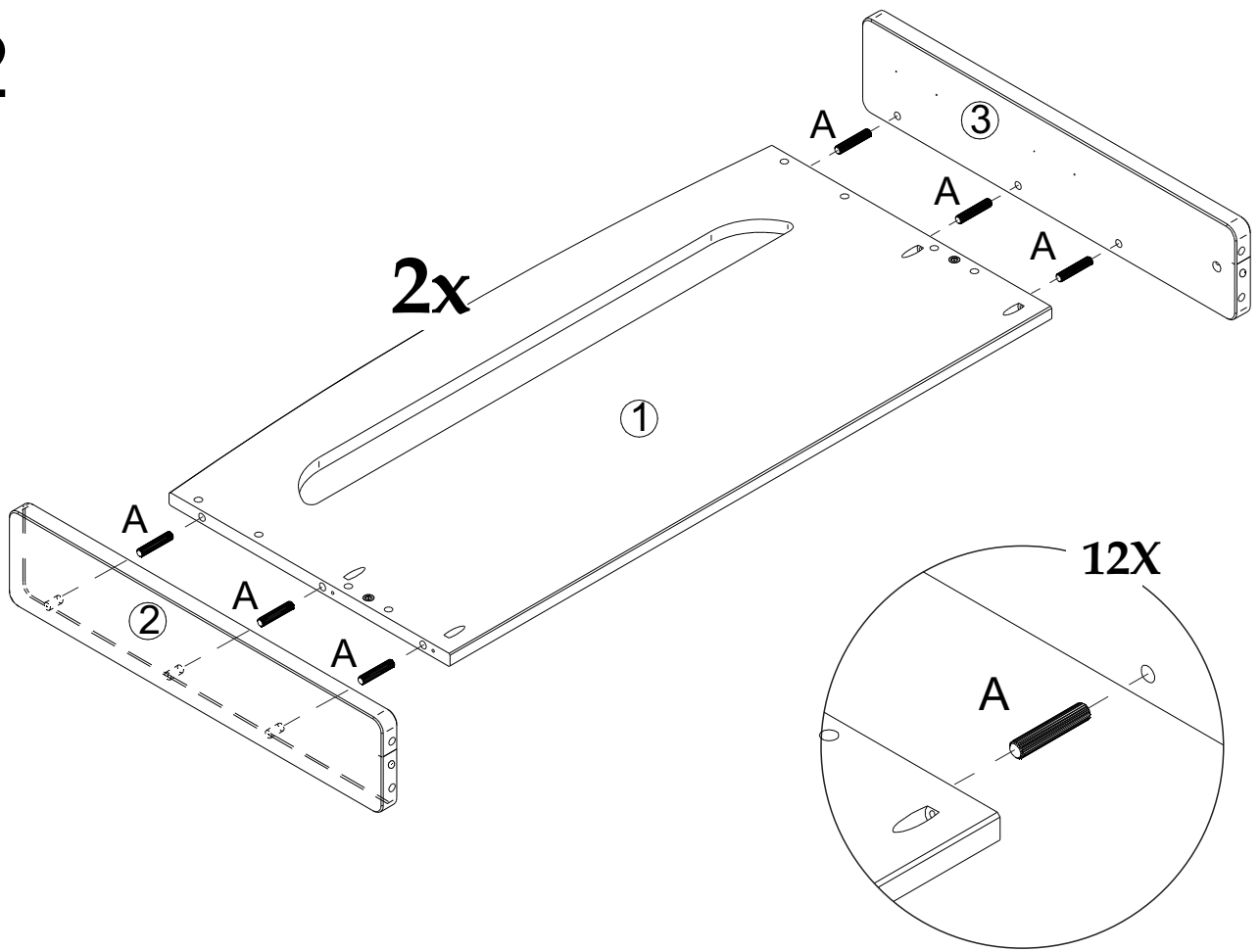

3

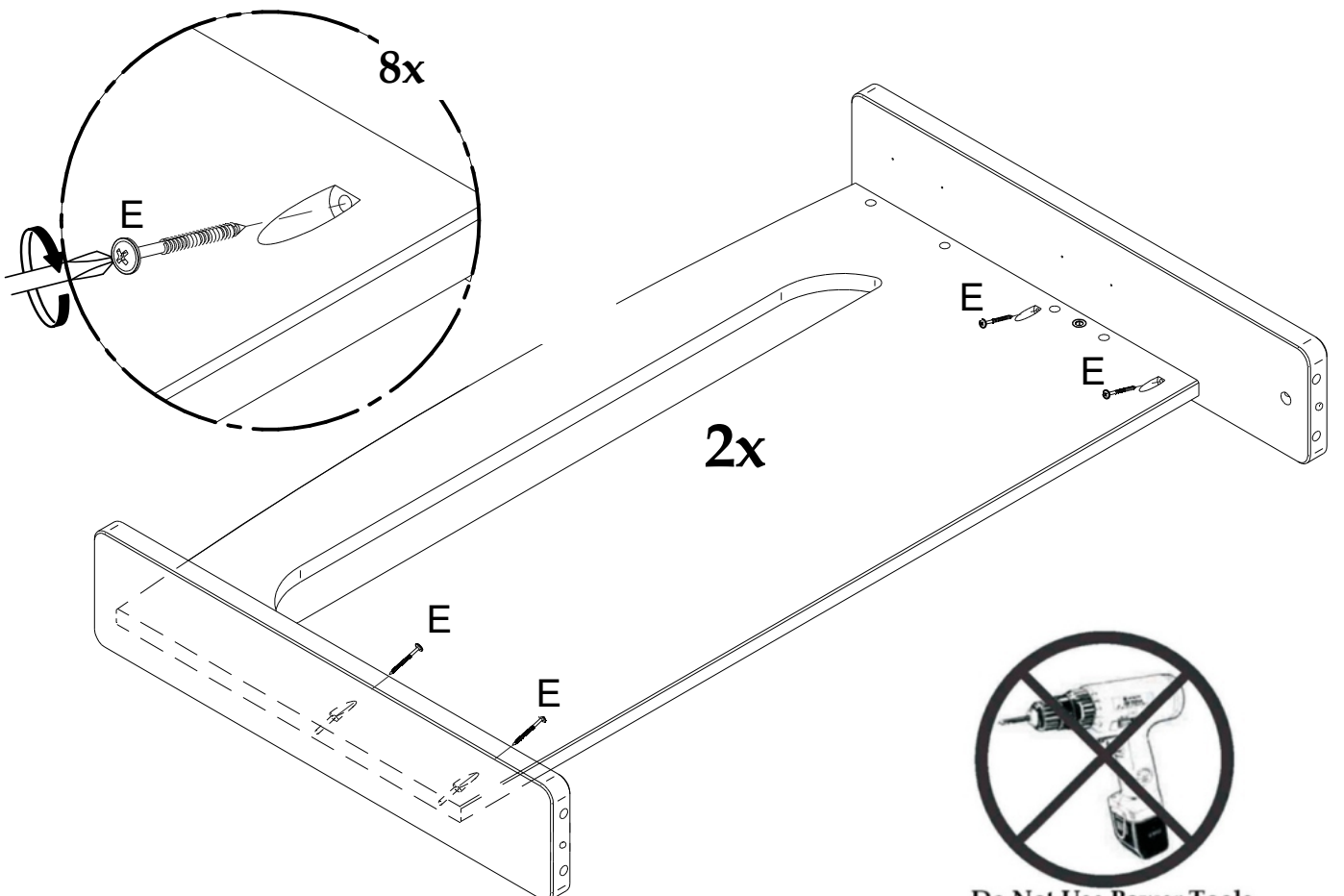

Do Not Use Power Tools

4

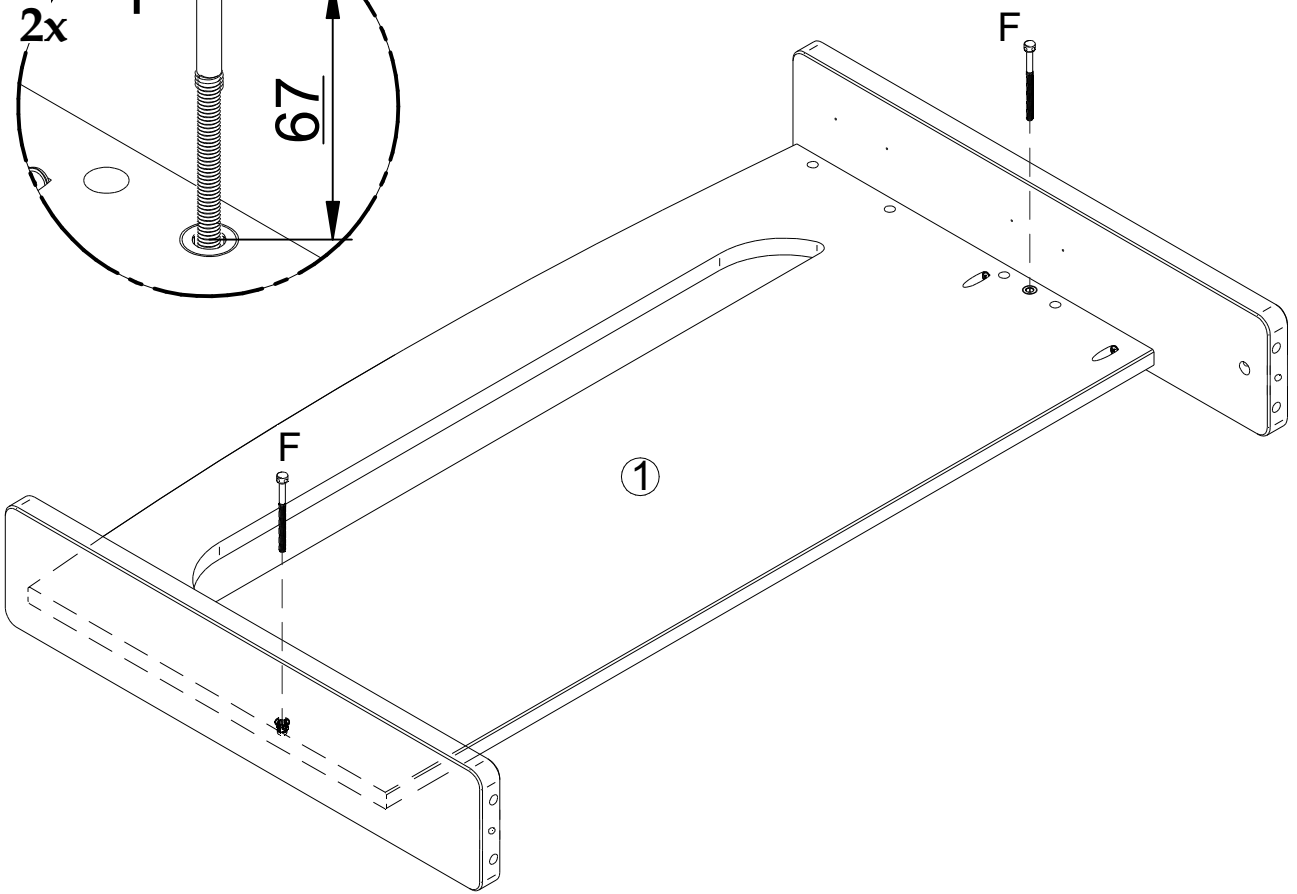
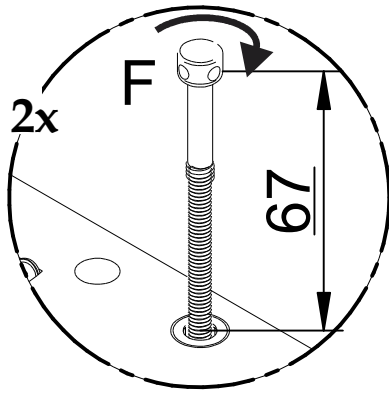

5

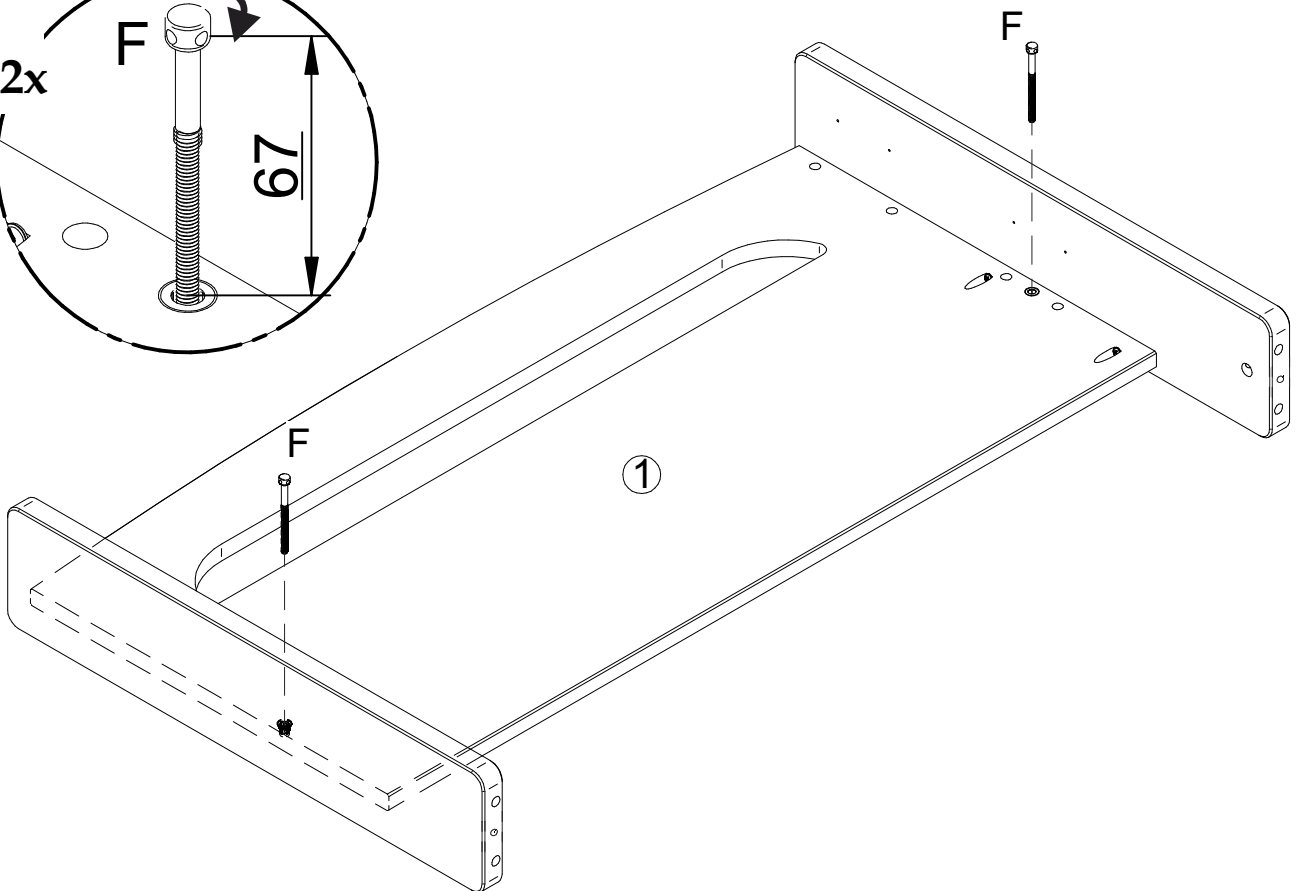
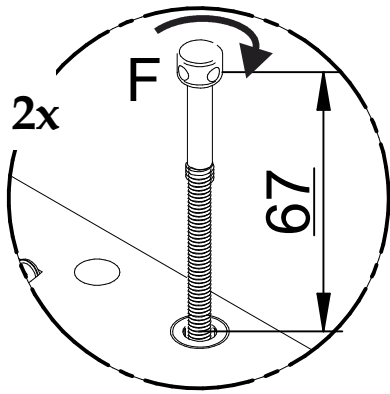

6

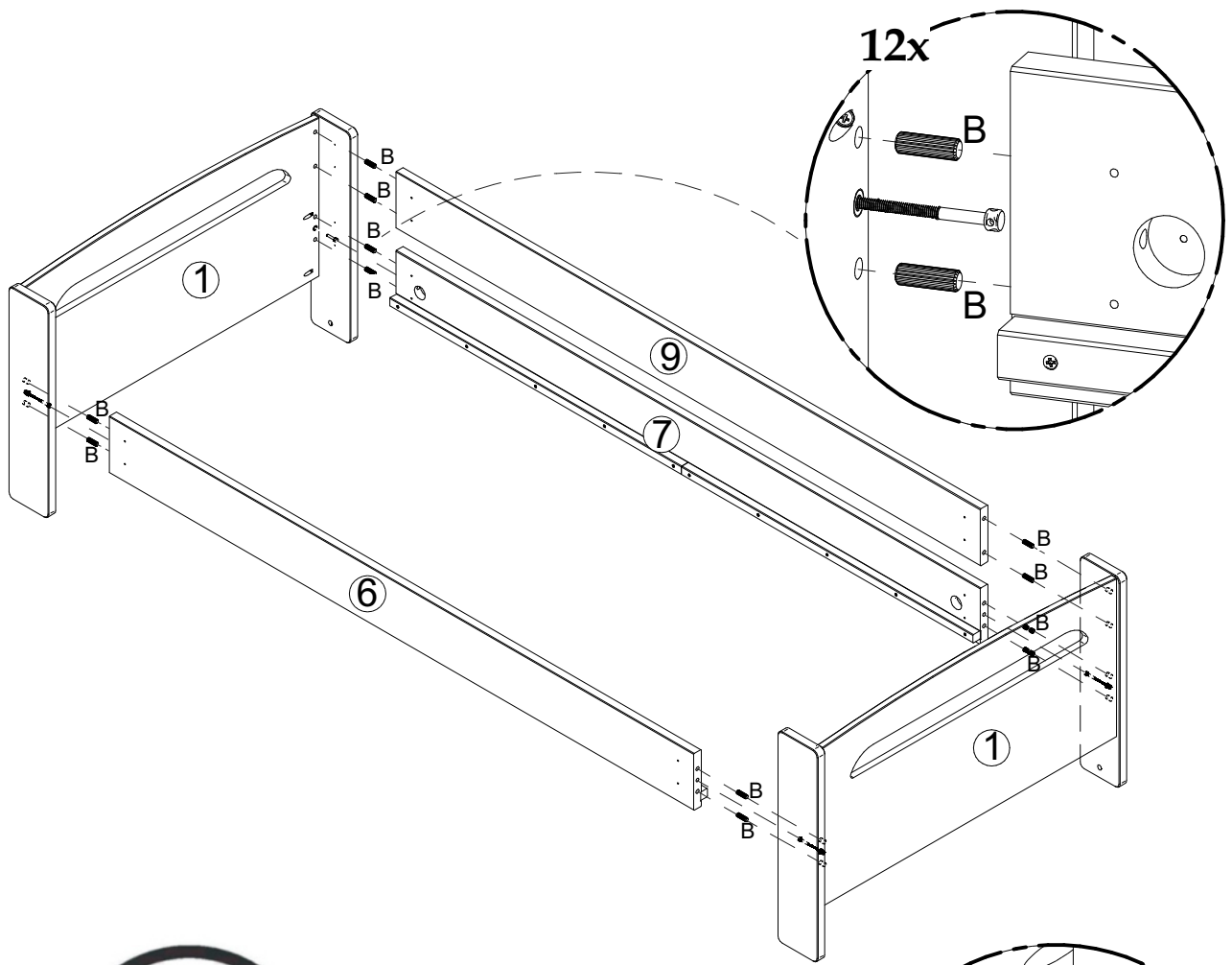

7



Do Not Use Power Tools

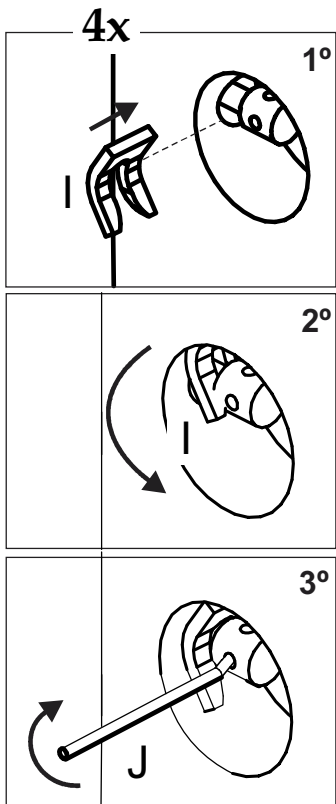
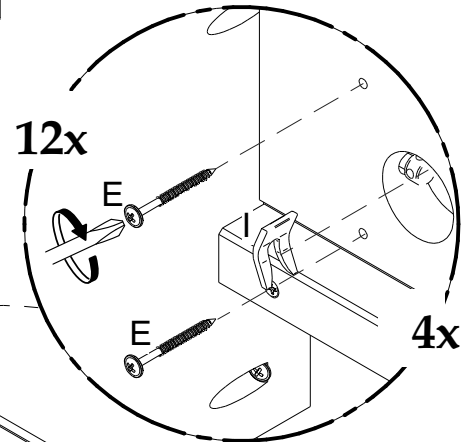

8

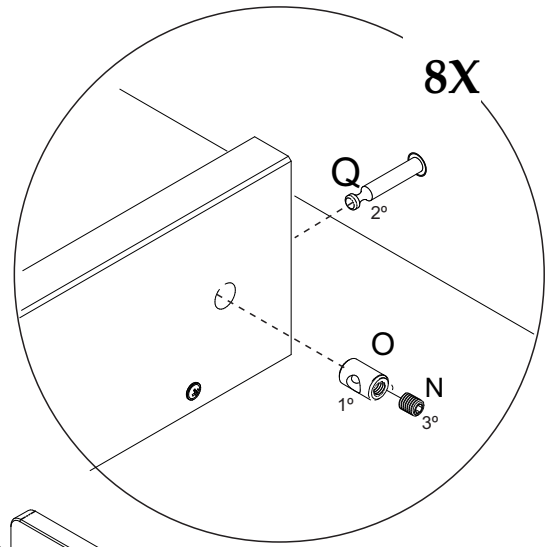
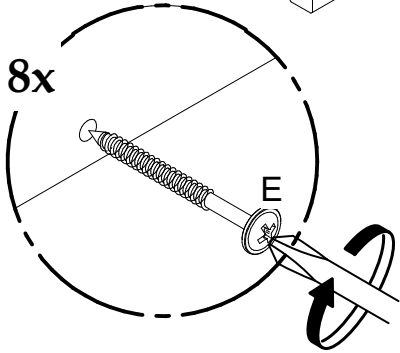
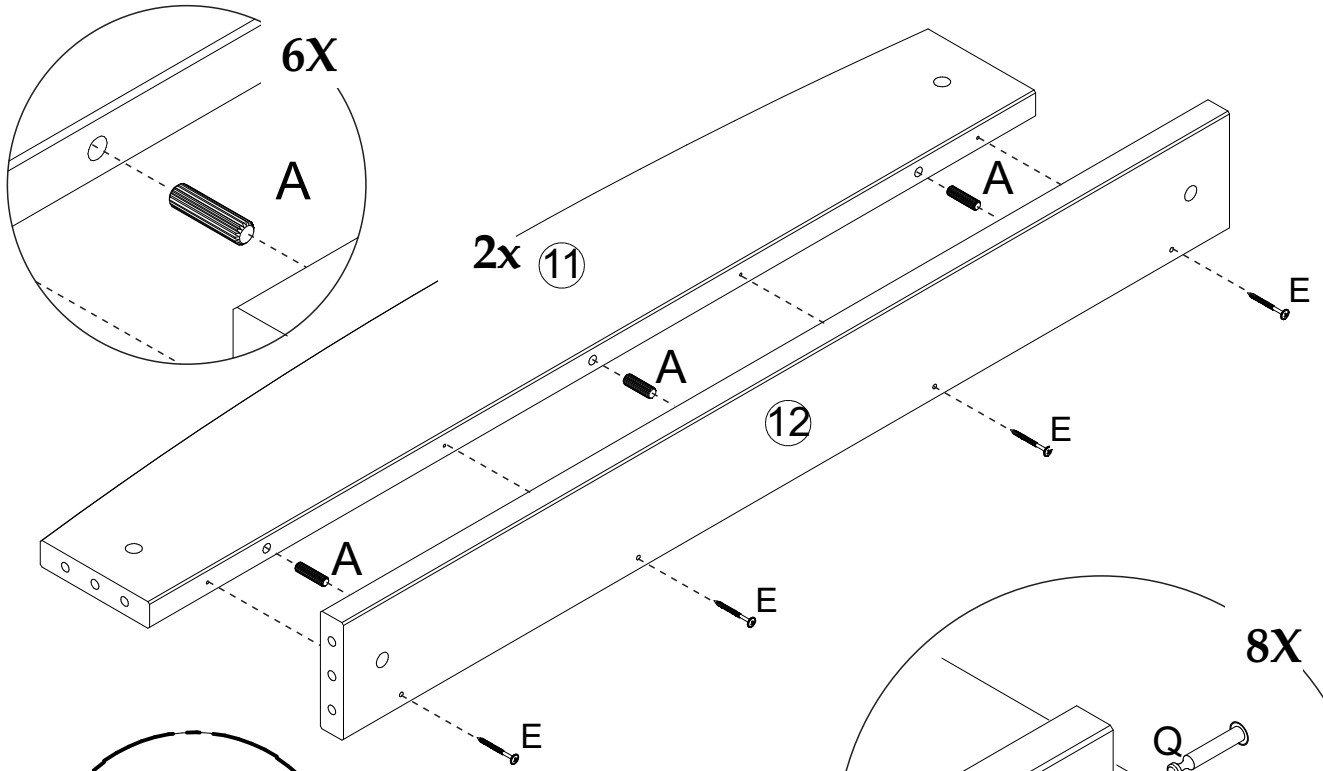

9



Do Not Use Power Tools

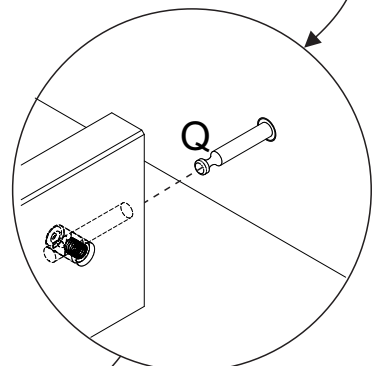
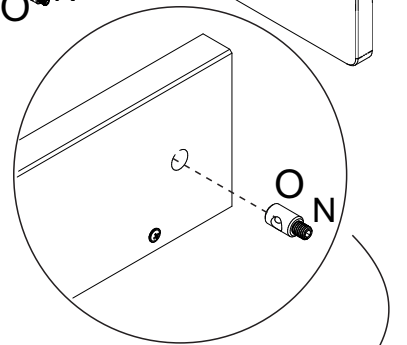
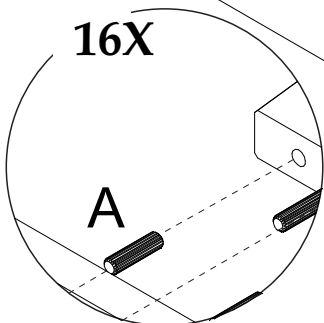
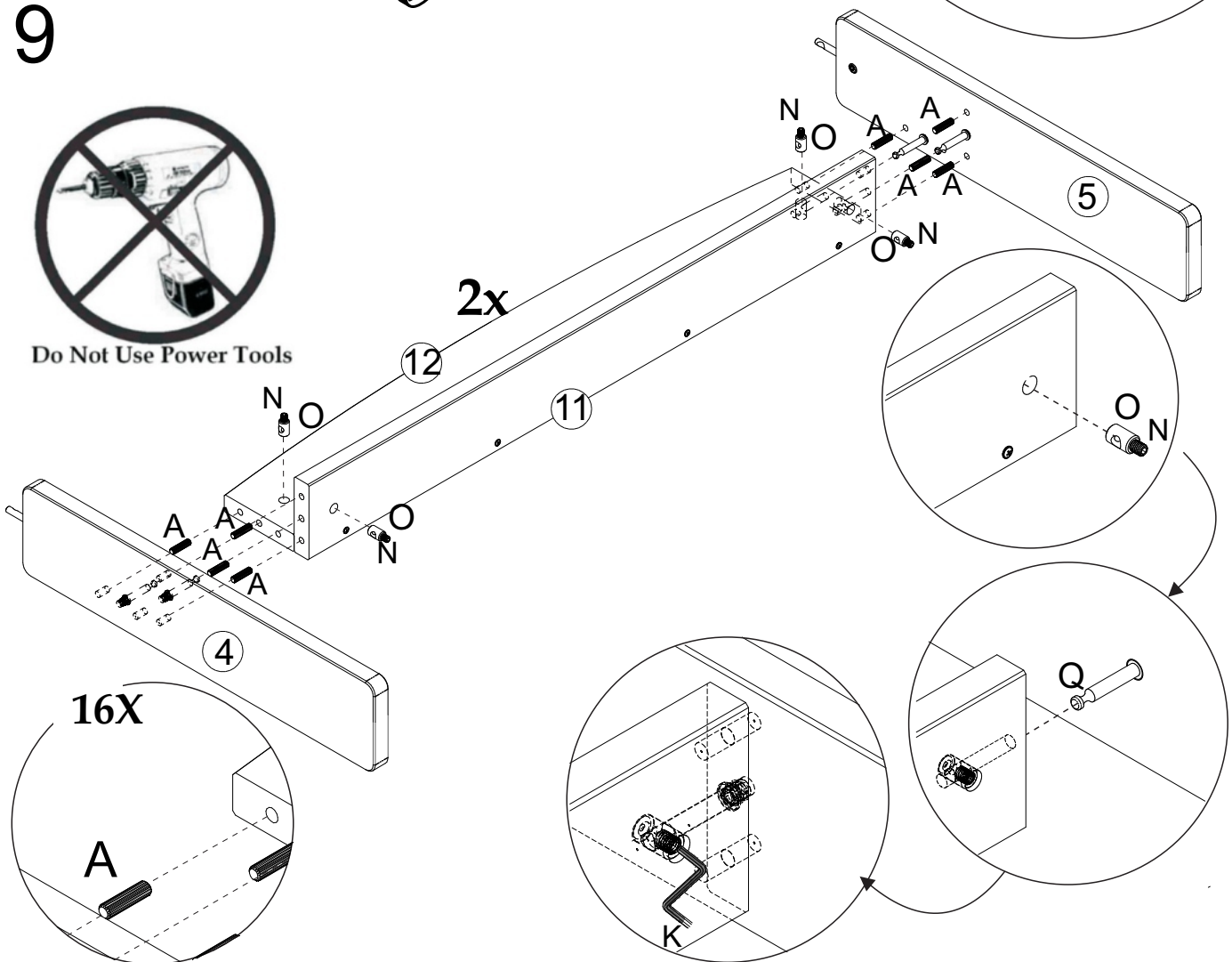

11

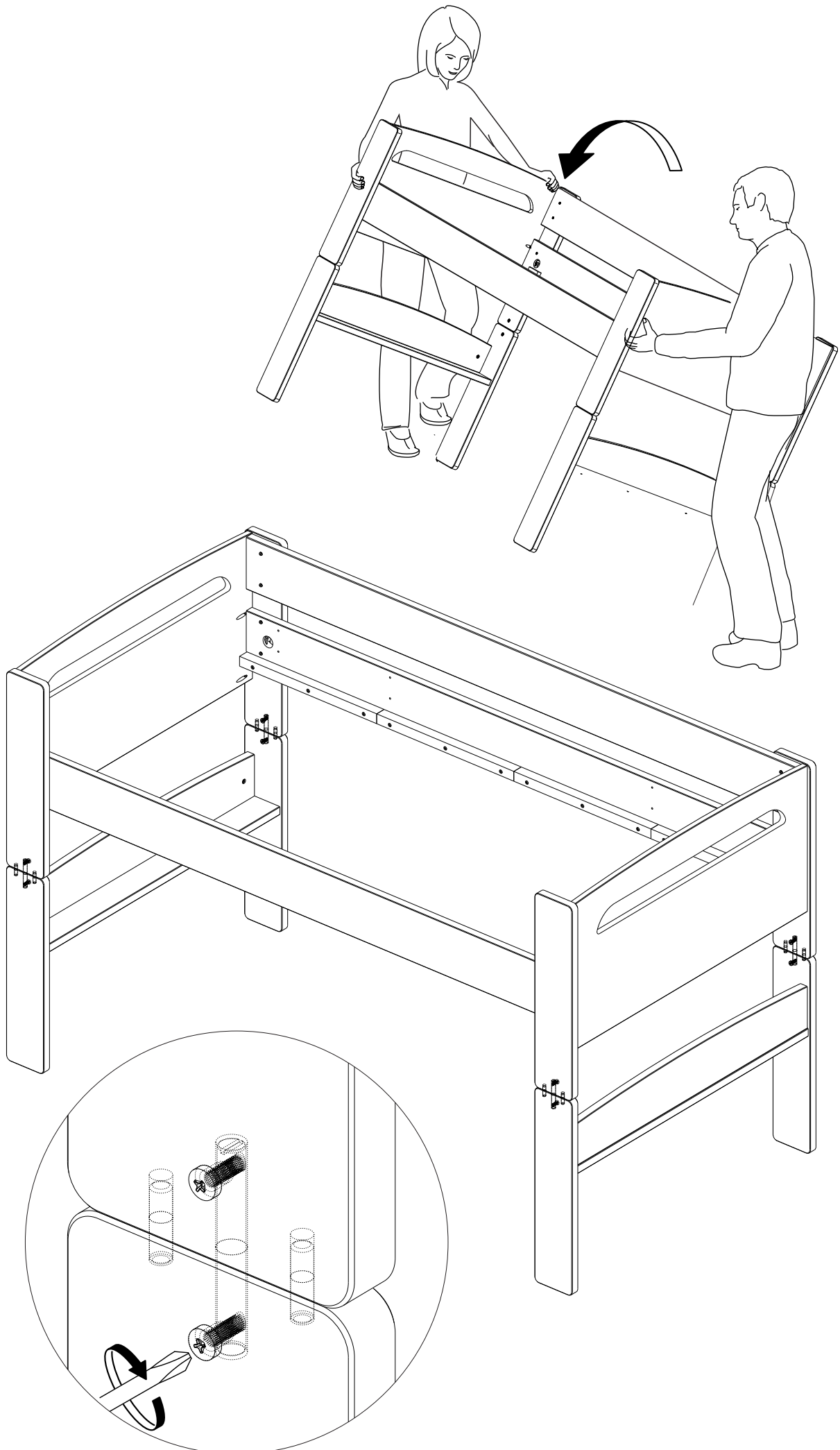

Fully tighten Part C

12

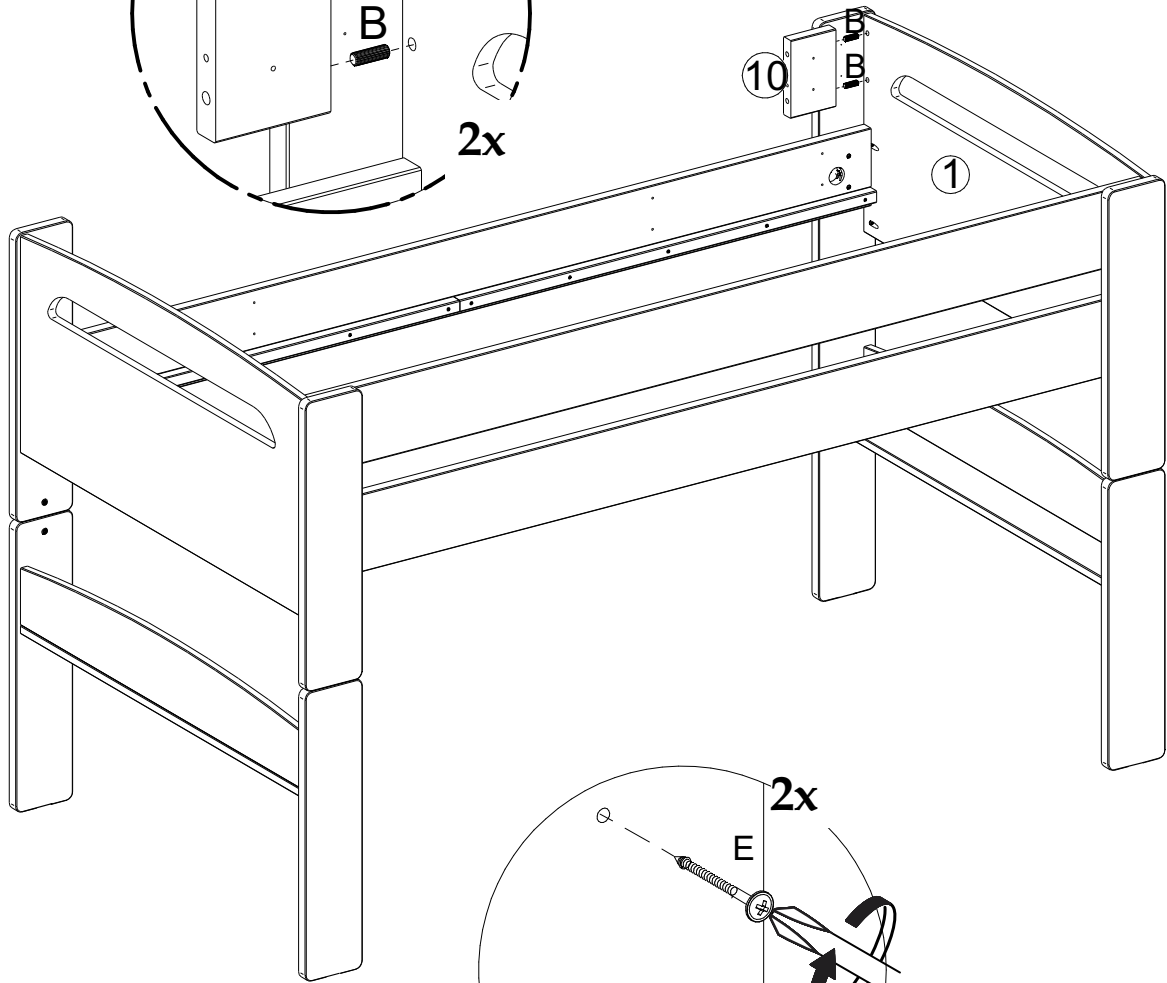
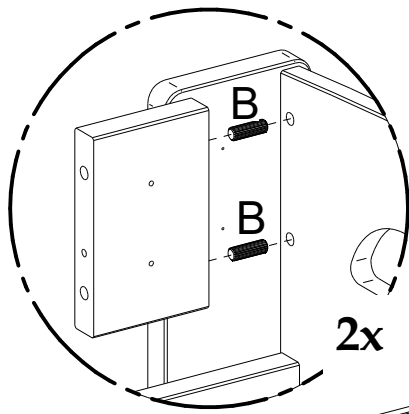

13

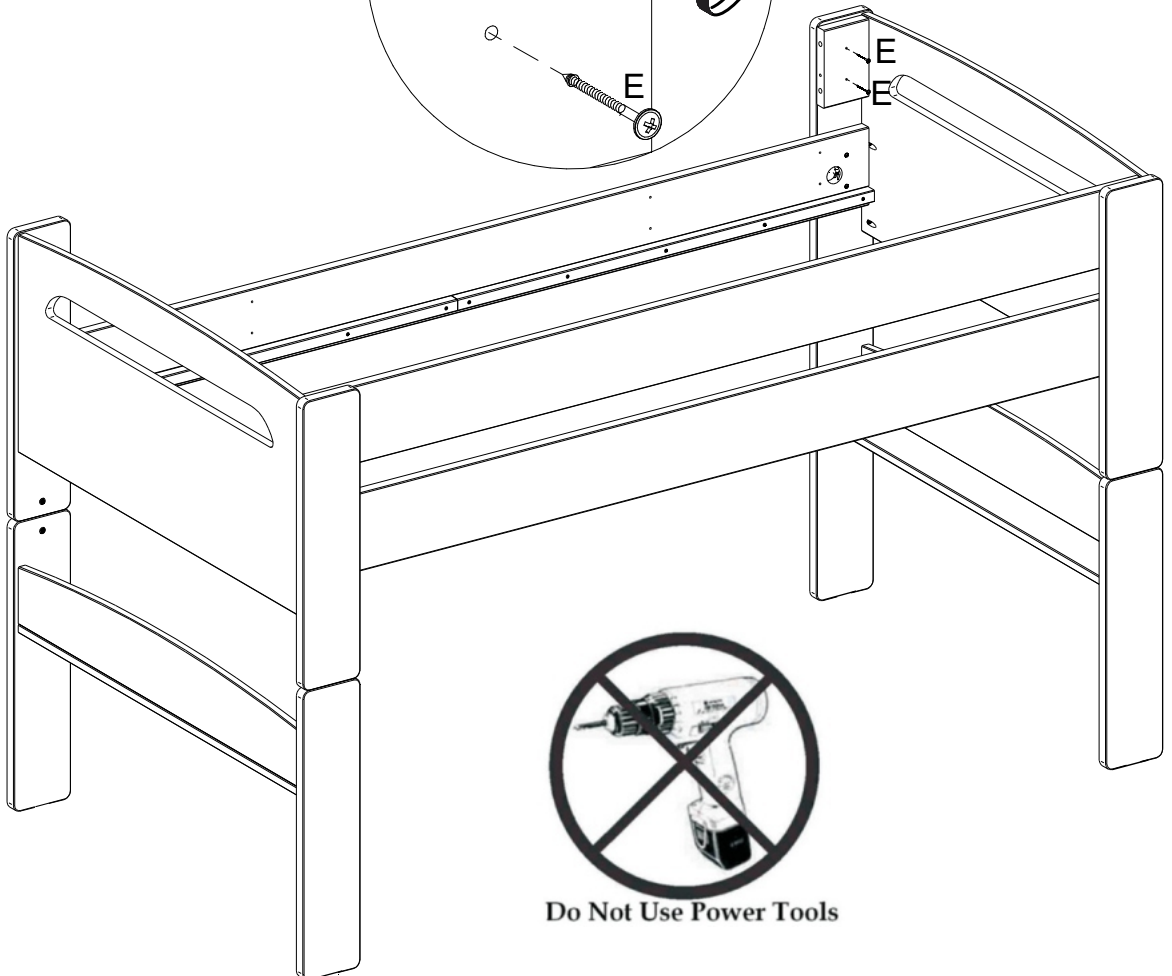
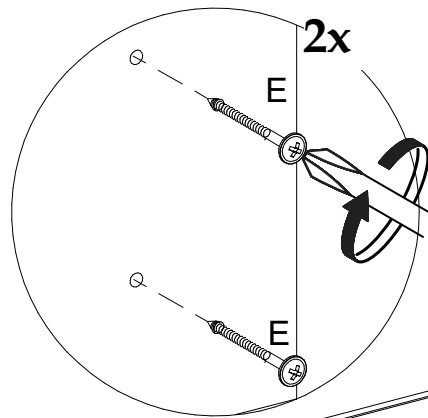

Do Not Use Power Tools

16

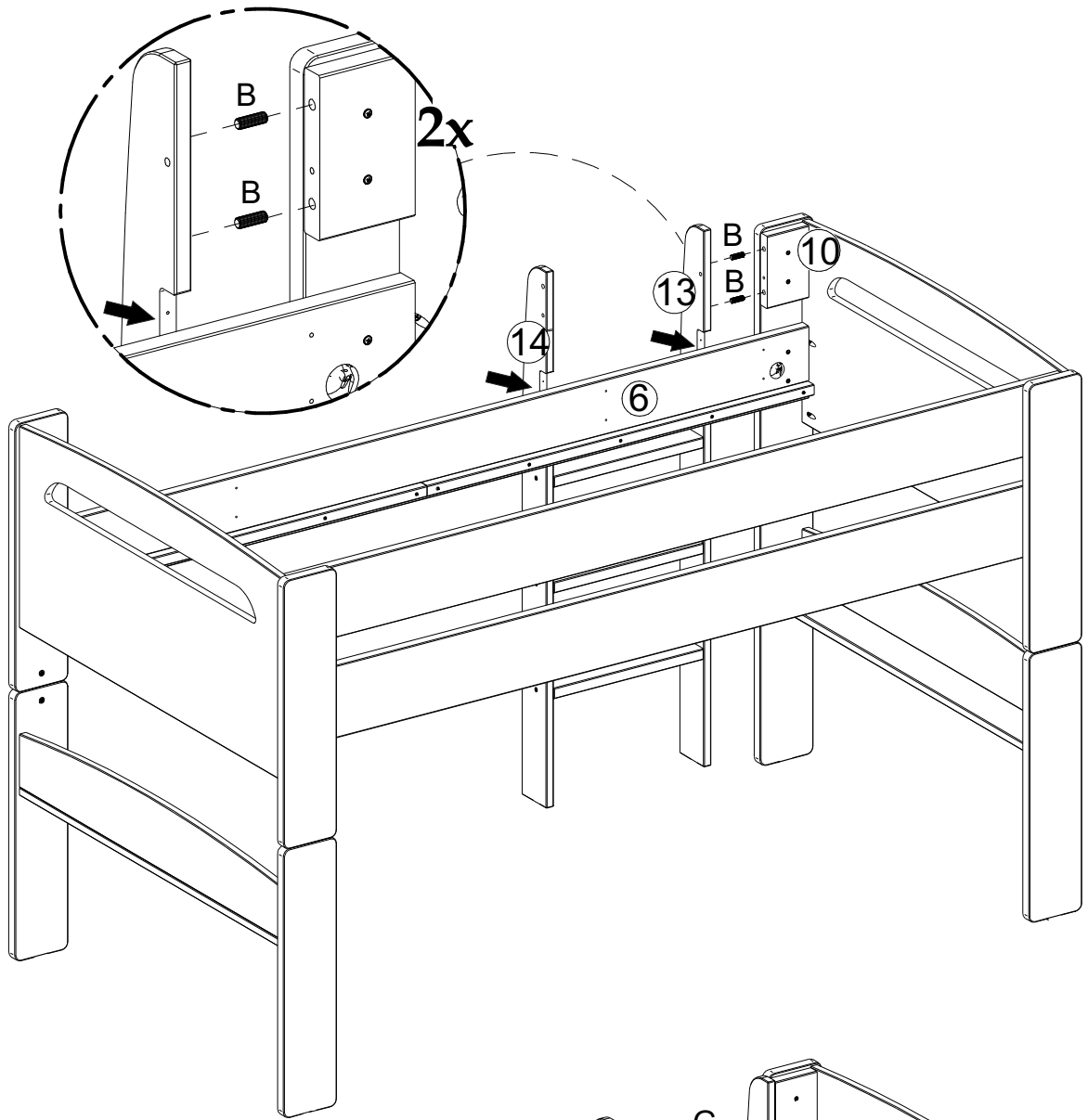

17

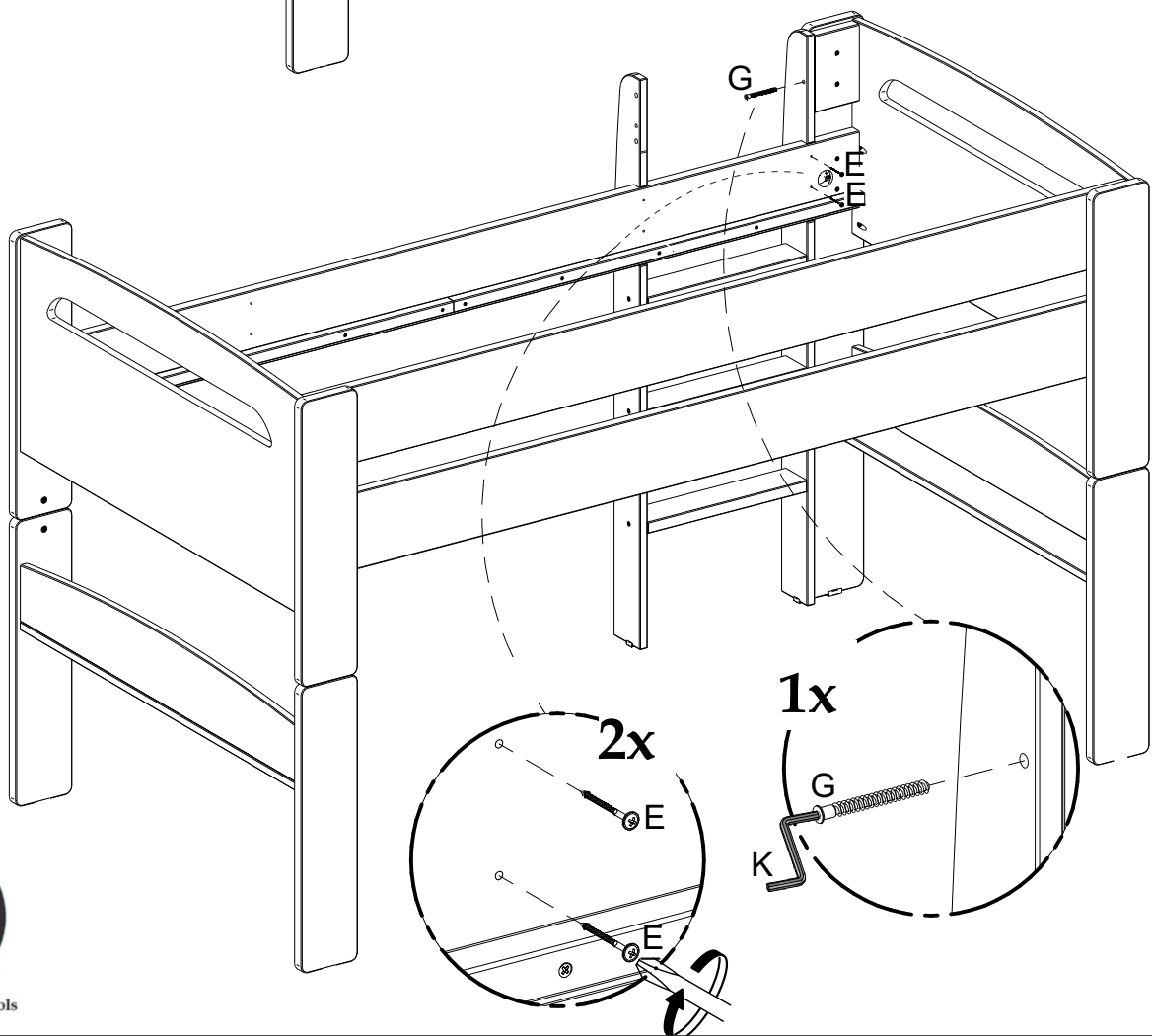

Do Not Use Power Tools

18

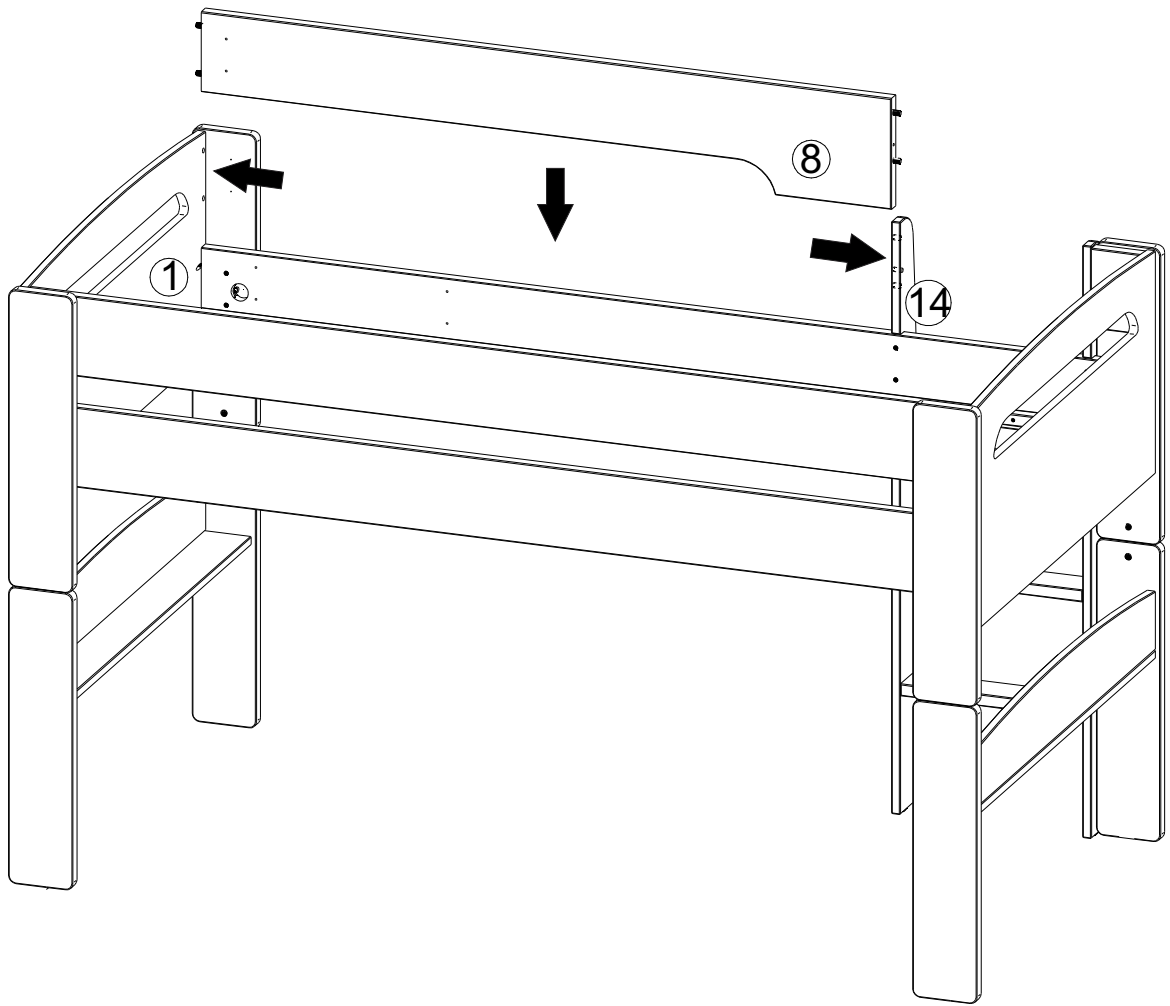

19

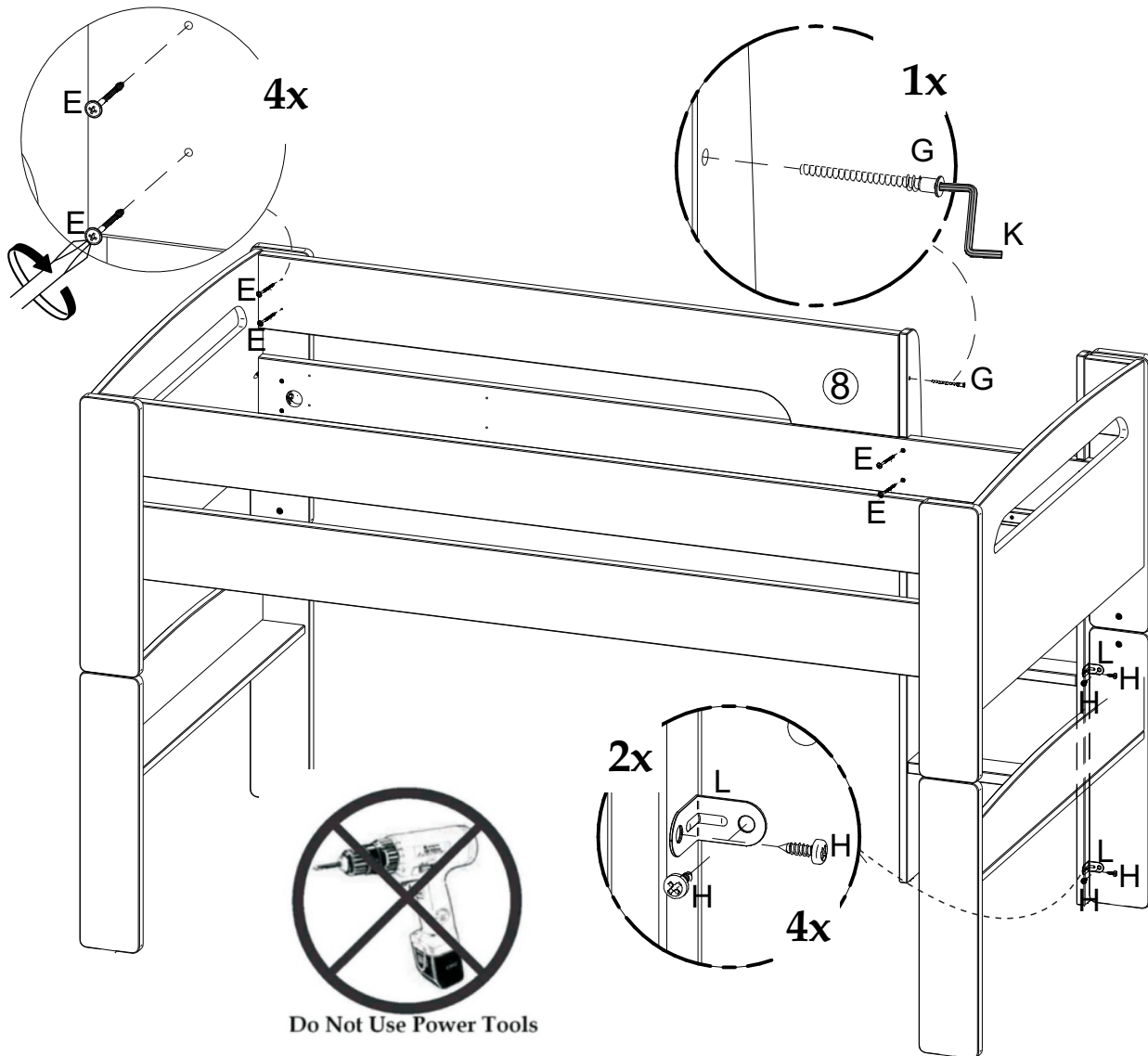

20



Do Not Use Power Tools

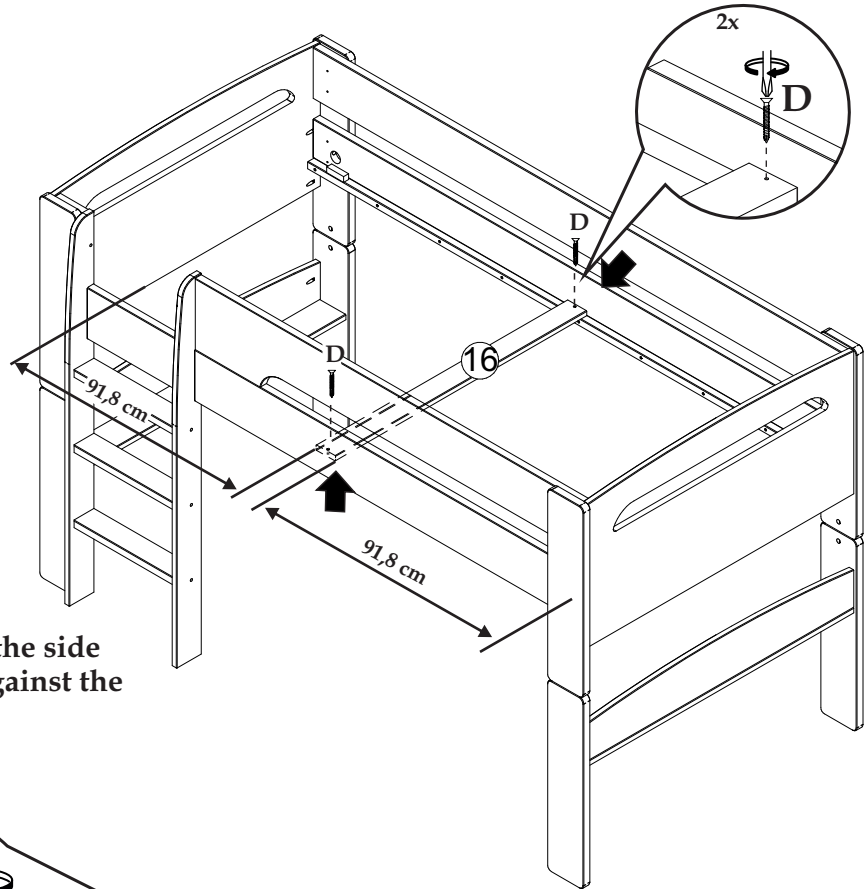

Attach the centre slat first by pushing the side rails together so that the slat is flush against the side rail, before inserting the screws.

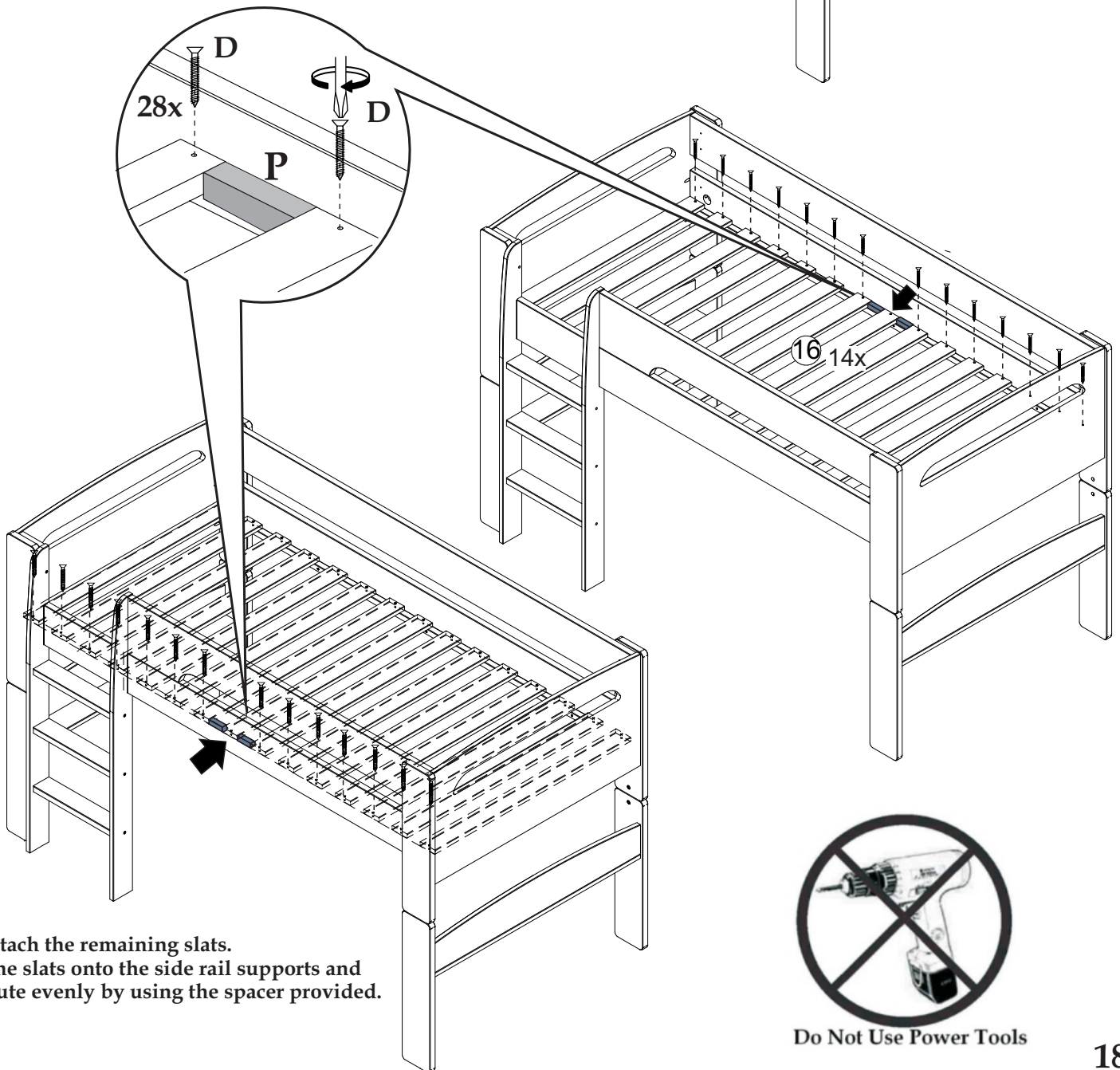

Next attach the remaining slats.
Place the slats onto the side rail supports and
distribute evenly by using the spacer provided.



Do Not Use Power Tools

IMPORTANT INFORMATION FOR USE AS A SINGLE BED

WARNING: This bed is not suitable for children under 4 years.

WARNING: Do not place this child's bed near heat sources, windows and other furniture.

WARNING: Do not use this child's bed if any part is broken, torn or missing.

It is recommended that you always follow the manufacturer's instructions to assemble this product.

This product is intended for use by children over 4 years of age.

Children are likely to play, bounce, jump and climb on beds, therefore the child's bed should not be placed too close to other furniture or windows, blind cords, curtain pulls or other strings or cords and should be placed either tight to the wall or have a gap of 300mm between the wall and side of bed.

This bed may not be dismantled for storage or transportation. Replacement parts can be obtained from _____ where available and at additional cost.

Recommended Mattress Size: 90cm x 190 cm (UK Single) with a depth of no more than 23 cm.

It is necessary to frequently ventilate the room in order to keep the humidity low and to prevent mould in and around the bed.

Please periodically check all the fixings of the item and re-tighten when necessary.

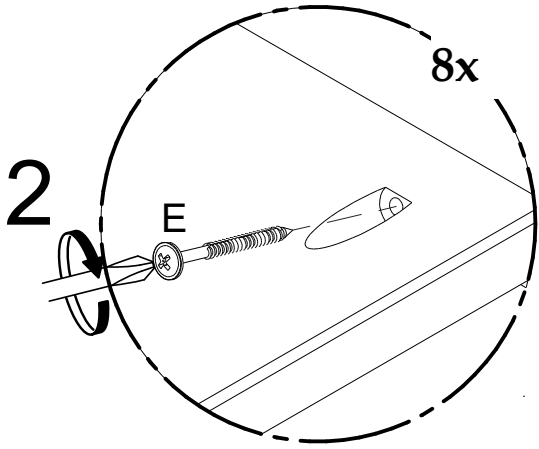
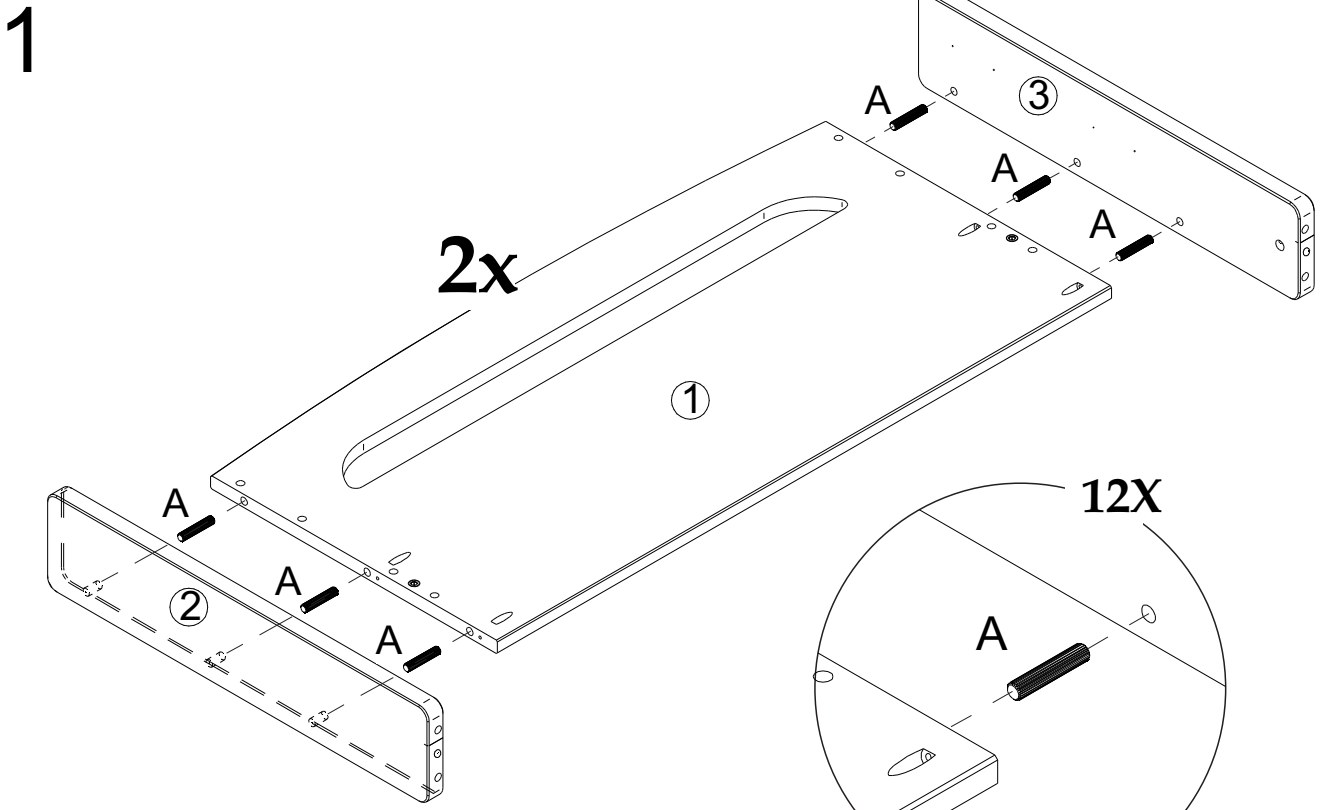

Do Not Use Power Tools

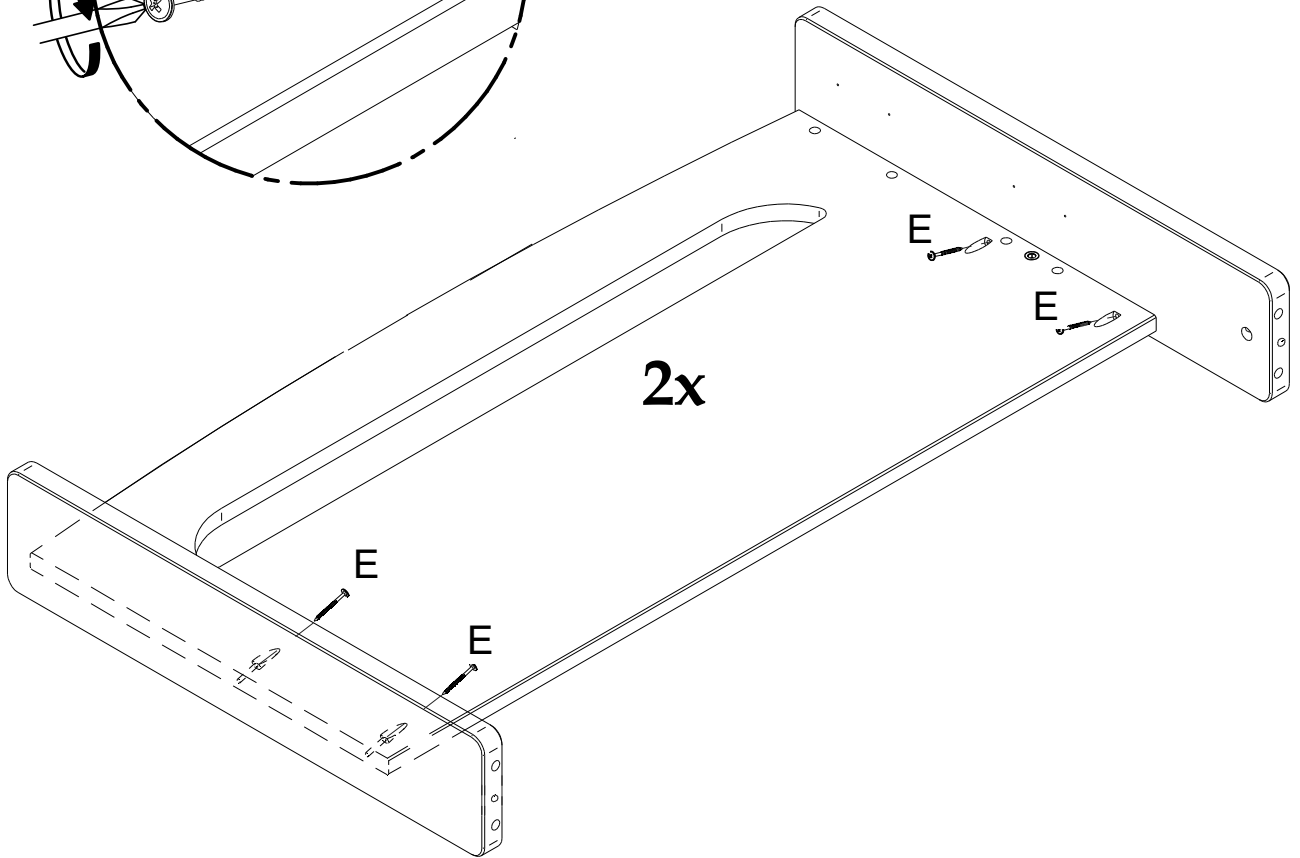

3

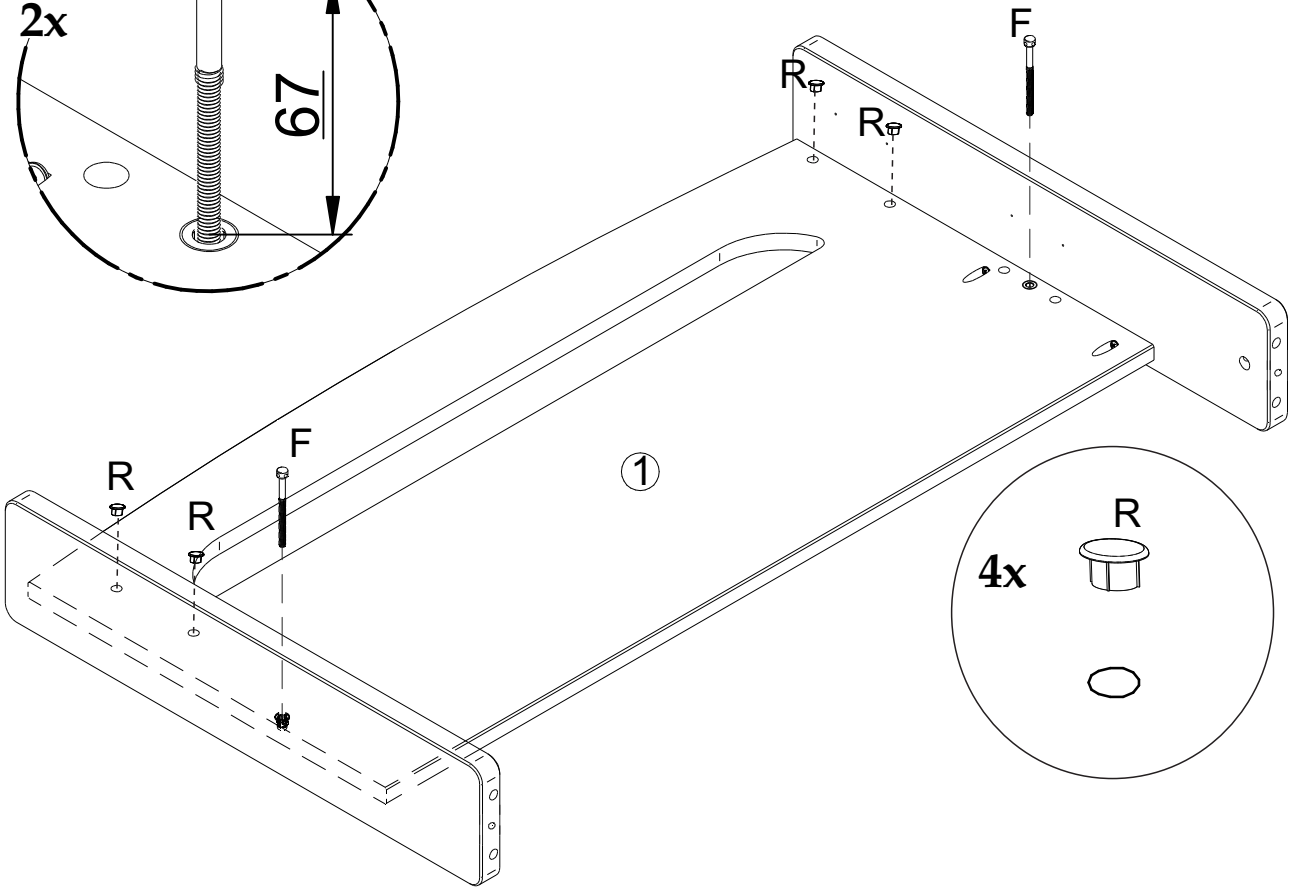
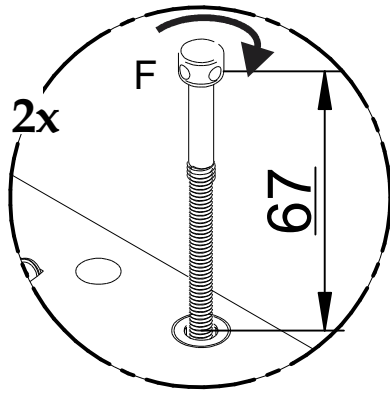

4

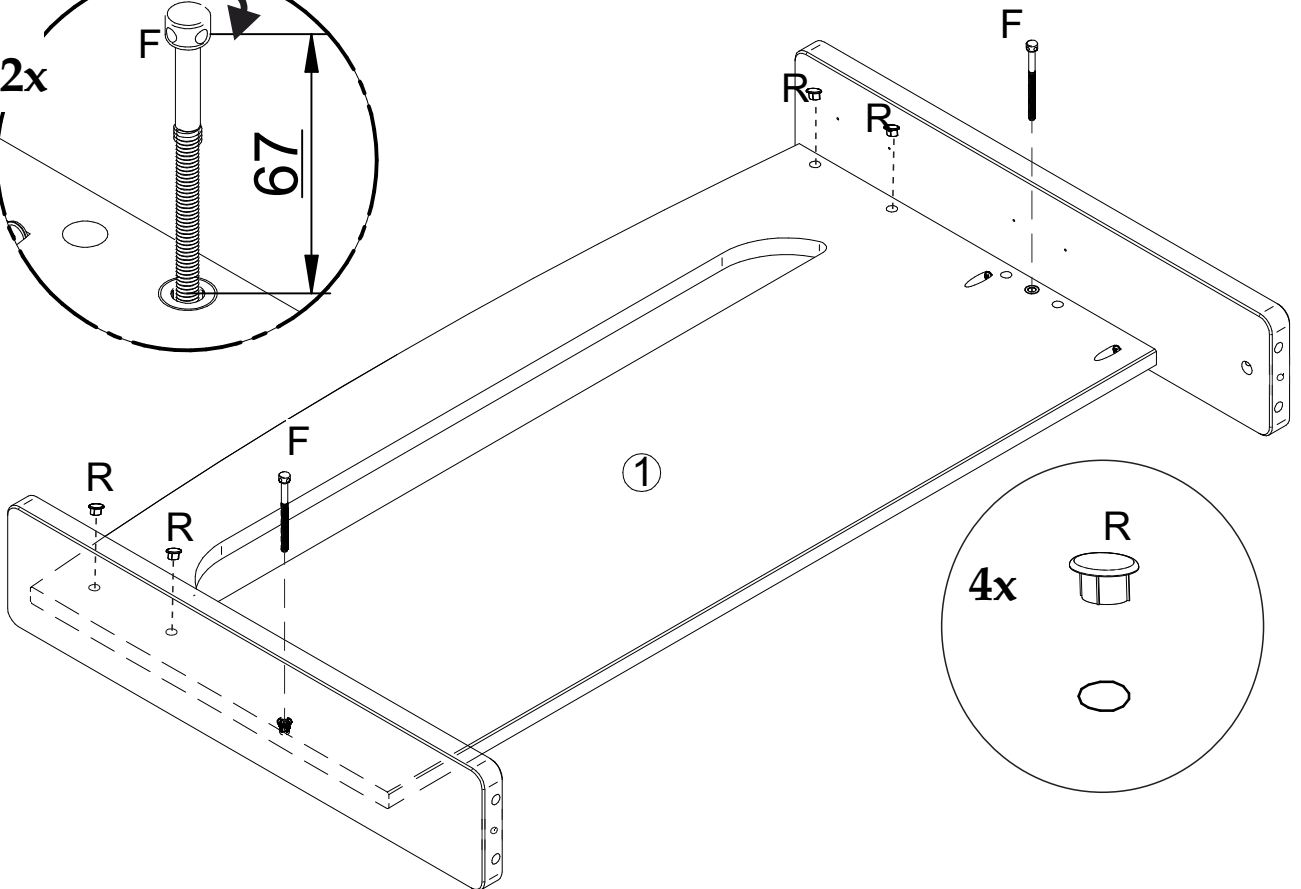
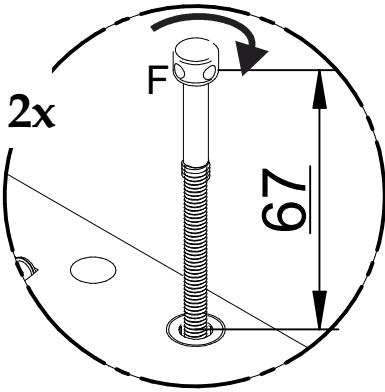

5

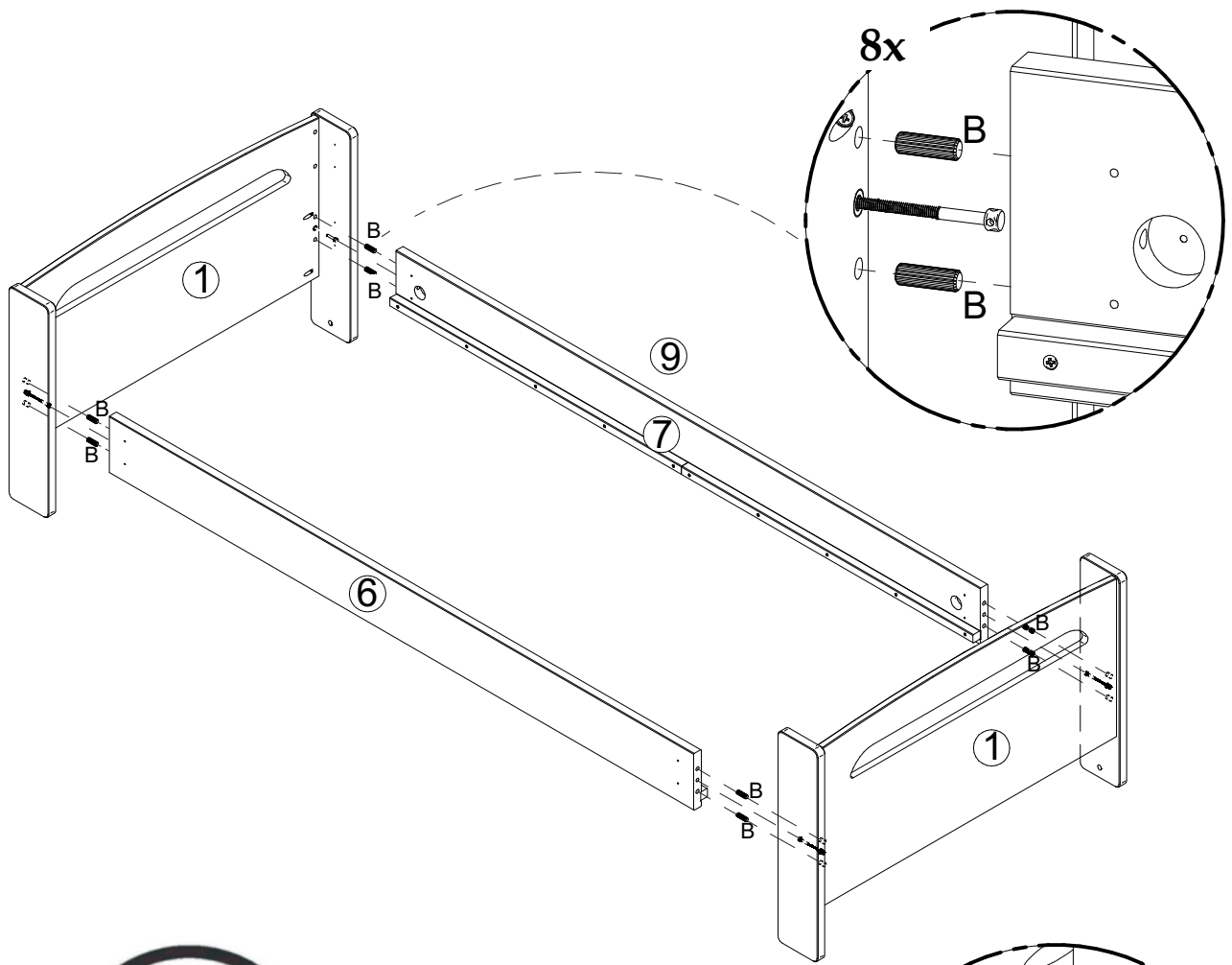

6



Do Not Use Power Tools

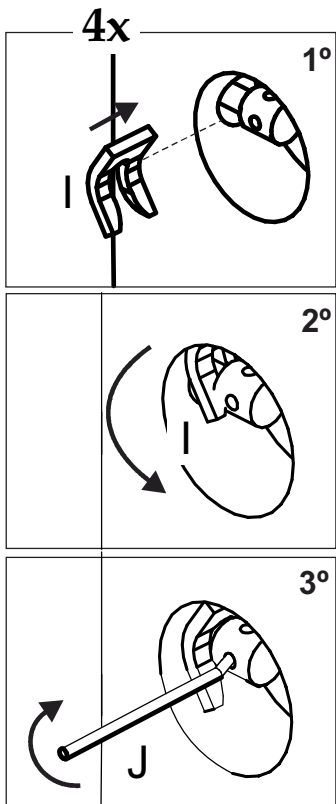
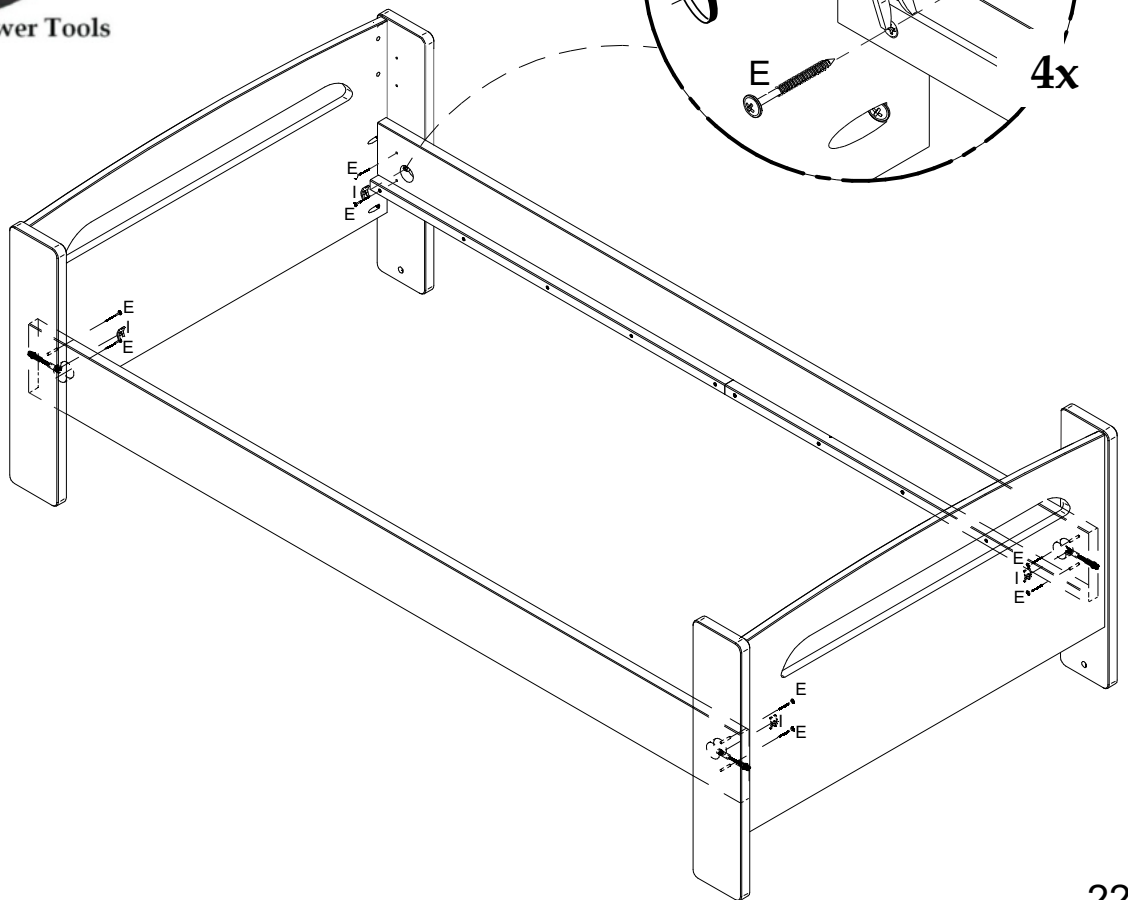
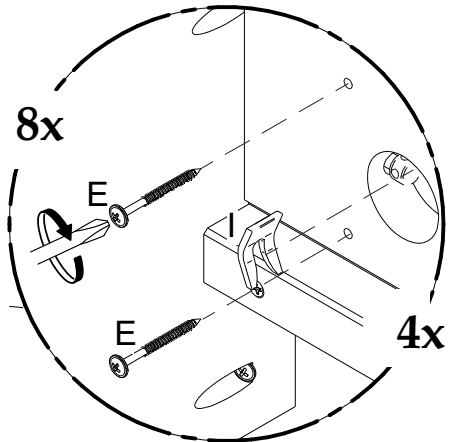

7



Do Not Use Power Tools

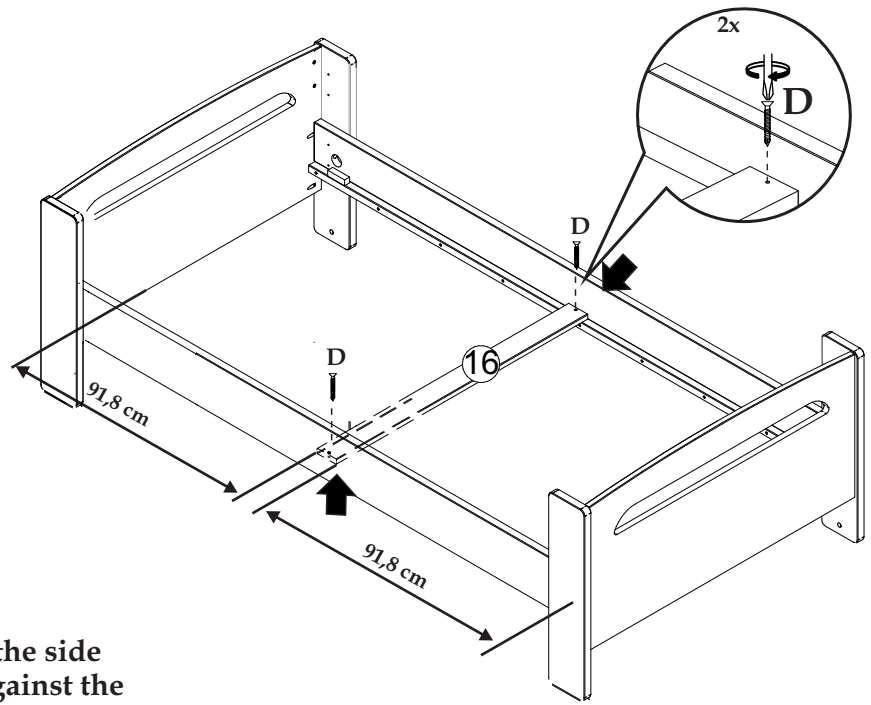

Attach the centre slat first by pushing the side rails together so that the slat is flush against the side rail, before inserting the screws.

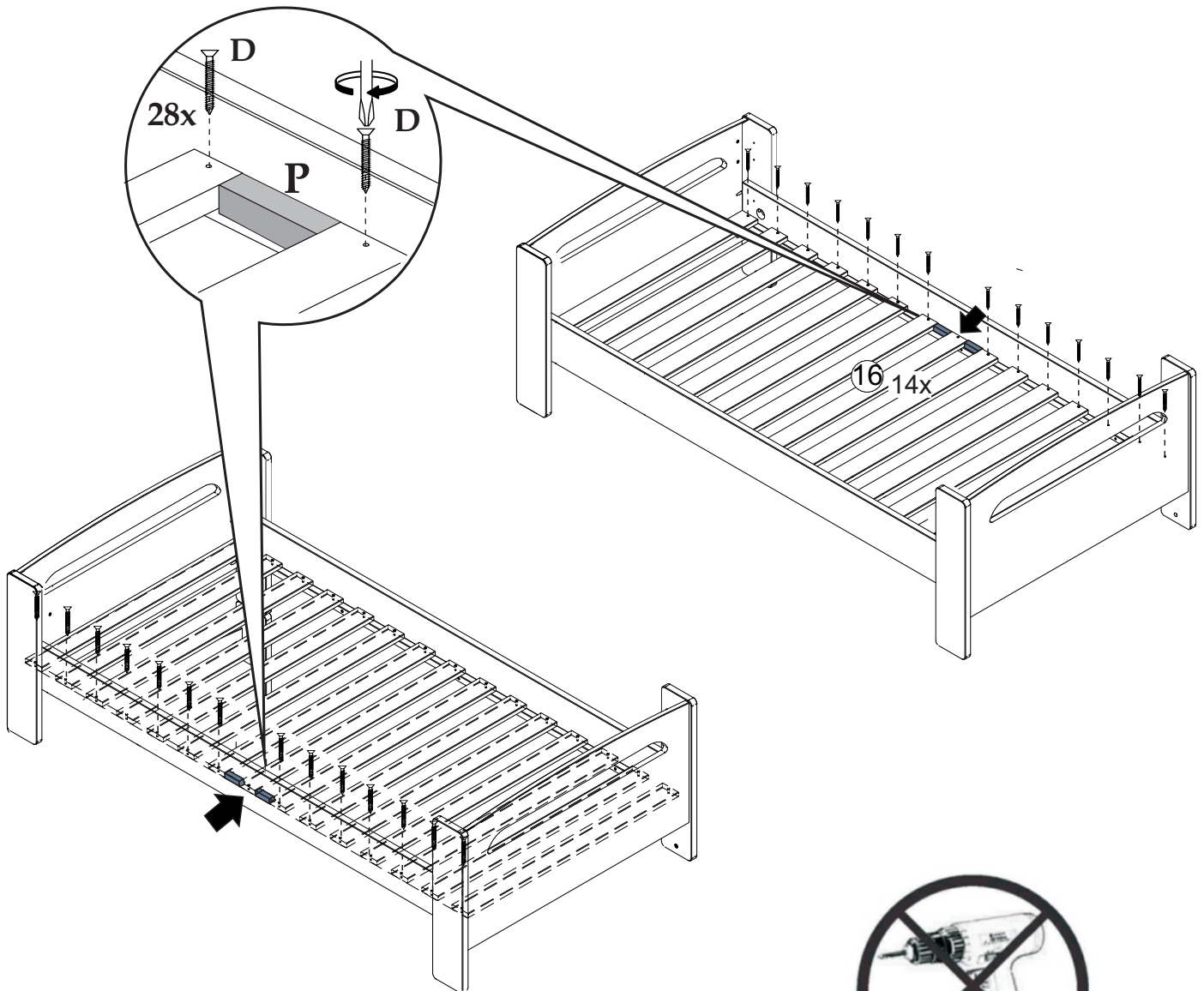

Next attach the remaining slats.
Place the slats onto the side rail supports and
distribute evenly by using the spacer provided.



Do Not Use Power Tools

General Care

Wipe clean with a slightly damp soft cloth.

Avoid the use of all household cleaners and abrasives.

When moving your furniture, carefully lift into place.

Never drag or push the pieces across the floor as this will cause damage to the joints and could result in failure to the product that will invalidate the warranty.

Recommendations

Periodical re-tightening of fixings.

Warning

This unit is heavy. Please use an assistant when lifting.