

ASSEMBLY INSTRUCTIONS

PARTS LIST

①

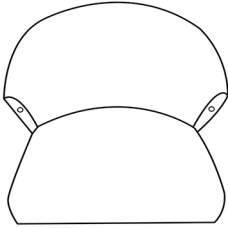

②

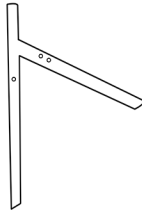



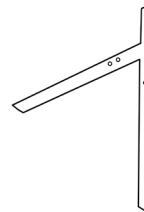



③



Part	Description	Qty
1	Seat Frame	1
2	Left Leg	1
3	Right Leg	1

HARDWARE LIST

Part	Diagram	Description	Qty
A		Bolt M8*45MM	6
B		Bolt M8*55MM	2
C		Spring Washer	6
D		Flat Washer	6
E		Allen Key	1
F		Plastic cap	2

1

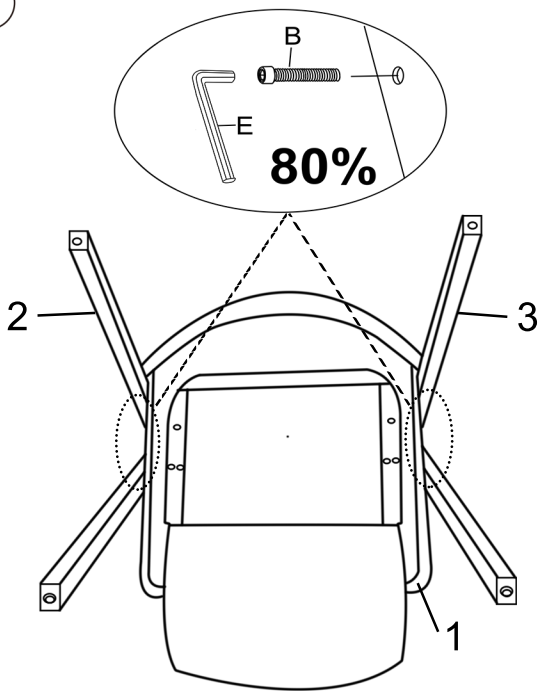

Put the screws in the holes,
tight the screws, but not too tight, 80% is ok.

2

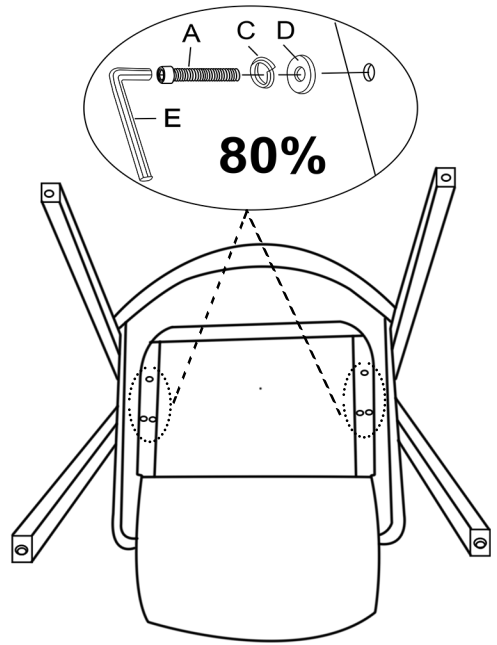

Put the screws in the holes,
tight the screws, but not too tight, 80% is ok.

3

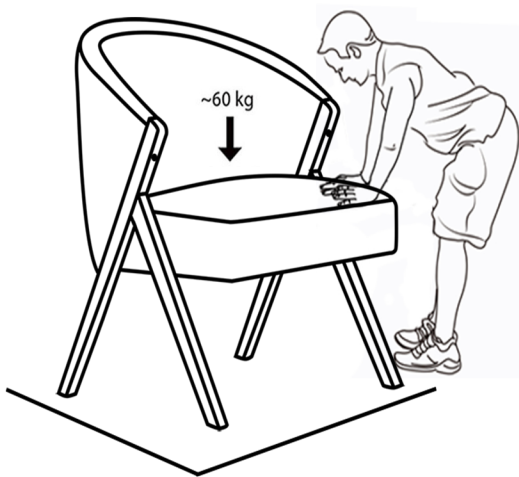

Ensure the chair is placed on a level surface.
Put a load of approx. 60KG on to the seat.
Adjust until all 4 legs are level –
before you carefully tighten the screws.

4

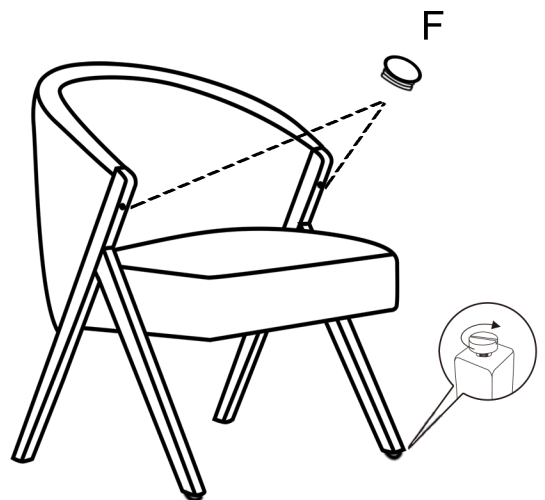

Turn the pin at the bottom of
the front legs to make chair level.
NOTE! The screws must be tightened after
a period of use, and thereafter as required.