

# ASSEMBLY INSTRUCTIONS

## **Dresser Gales 3 Drawer**

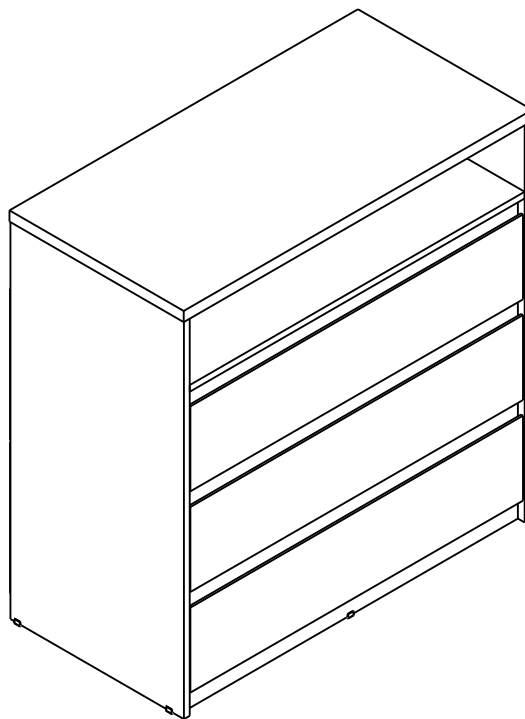

---

Below are the tools no provided but necessary for the product assembly.



## Parts of the product

- 1 Left Side (1x)
- 2 Right Side (1x)
- 3 Top Cover(1x)
- 4 Shelf (1x)
- 5 Skirting and Front View (4x)
- 6 Rear Skirting (1x)
- 7 Drawer Front (1x)
- 8 Left Drawer Side (3x)
- 9 Right Drawer Side (3x)
- 10 Drawer Back (3x)
- 11 Drawer Bottom Support (3x)
- 12 Dower Bottom (3x)
- 13 Coast (3x)

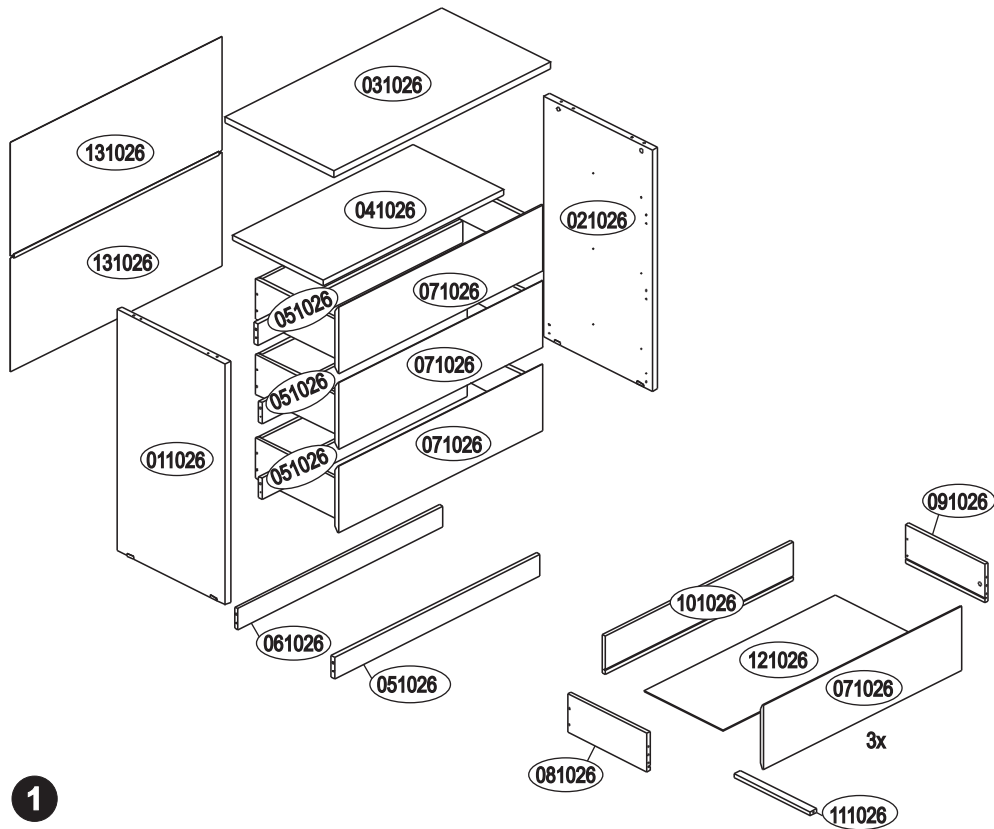

7

## Fix the anti tipping kit

- 1- Screw the chain (L) with the screw (P) and washer (O) on the piece 3.
- 2- Position the dresser next to the wall, mark the wall and drill with an 8mm drill and install the wall plug (M), fix the chain (L) to the wall with screw (N).

Step 1

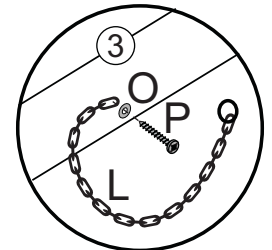

Step 2

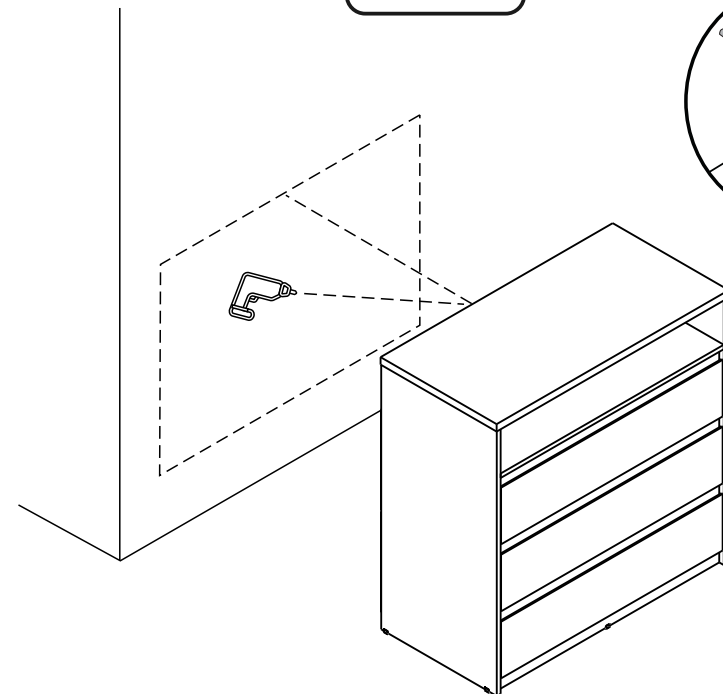
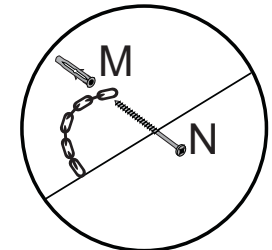

6

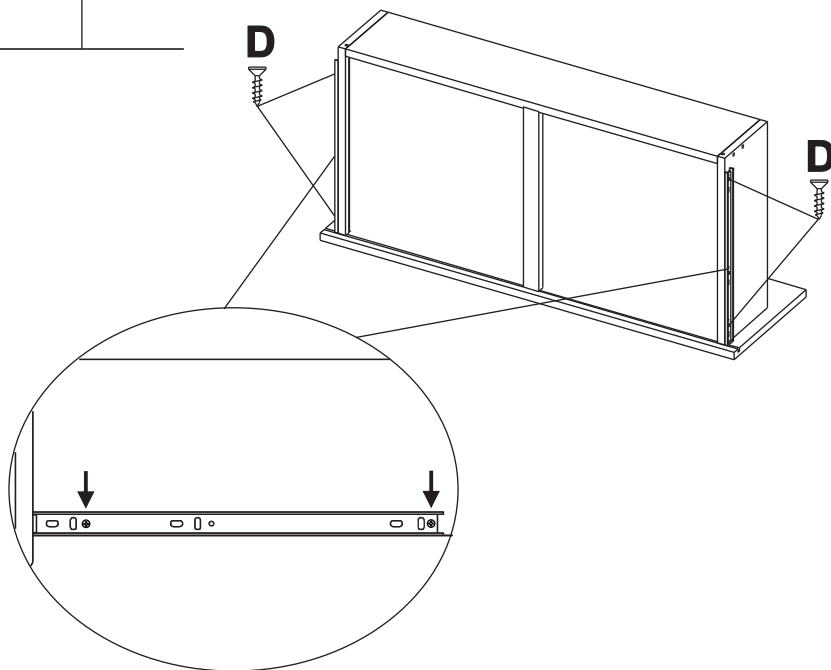

Stick self adhesive cap cover to finish.

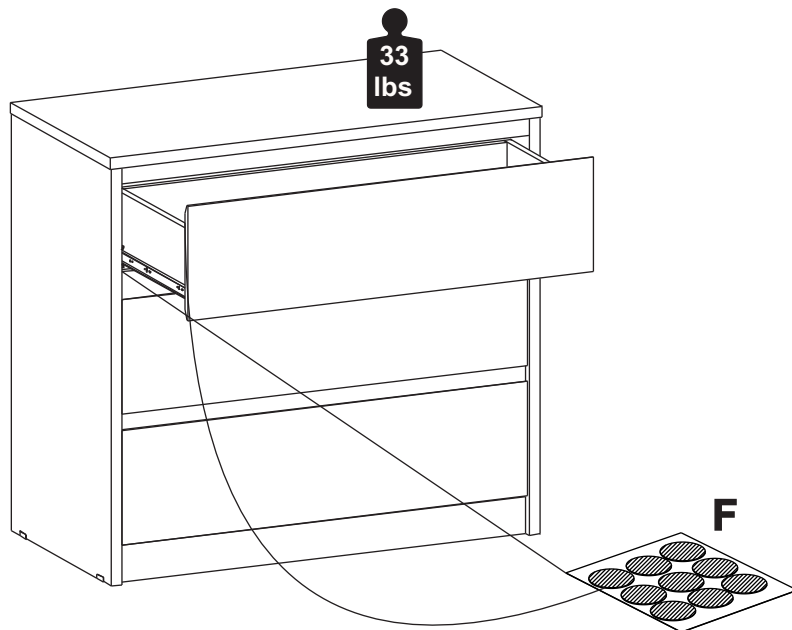

9

## Componentes

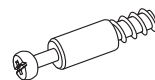

A-Twister dowel (24x)

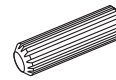

B- Wood Dowel  
Ø6x30 (38x)



C- Cam Lock (24x)



D- Screw  
Ø3,5x14 c.c. (26x)

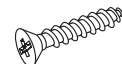

E- Screw  
Ø4,0x40 (12x)



F- Self Adhesive  
Cap Cover (12x)



G- Nail (40x)

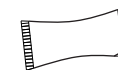

H- Glue (1x)



I- Plastic Foot (6x)

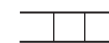

J- Bottom (1x)  
Connector

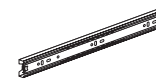

K- Slide  
Telescopic - A3331  
300mm (3 pairs)

L -

M -

N -

O -

P -

Anti tipping kit

### Lista de peças - caixa 01/01

Cód.	Qty.	DESCRIÇÃO
011026	01	Left Side 890 x 448 x 15mm
021026	01	Right Side 890 x 448 x 15mm
031026	01	Top Cover 900 x 450 x 25mm
041026	01	Shelf 865 x 448 x 15mm
051026	04	Front Views 865 x 60 x 15mm
061026	01	Rear Skirting 865 x 60 x 15mm
071026	03	Front Drawer 859 x 190 x 15mm
081026	03	Left Drawer Side 378 x 110 x 15mm
091026	03	Right Drawer Side 378 x 110 x 15mm
101026	03	Drawer Back 810 x 110 x 15mm
111026	03	Drawer Bottom Support 363 x 30 x 15mm
121026	03	Drawer Bottom 822 x 375 x 3mm
131026	02	Coast 890 x 338 x 3mm
-----	01	Hardware Kit
-----	01	Bottom Connector 864mm
A3331	03	Telescopic Slide 300mm

Use the ruler below to measure the components.

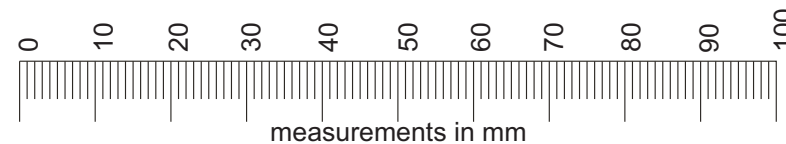

2

## For Assembly:



40 min.

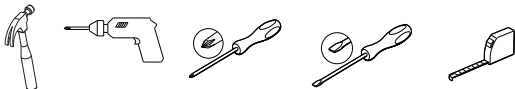

### Safety information

1. Reserve a free area for assembling the product.
2. The product must be assembled on a clean and flat surface.  
It is advisable to use the packaging itself to cover the floor so as not to damage it the pieces.
3. Avoid bumps and contact with sharp objects.
4. Do not expose the furniture to excessive heat (direct sunlight) or high humidity.
5. For cleaning, use a soft, dry cloth or one slightly dampened with water. Do not use cleaning agents or abrasives.
6. Two people are required to assemble.
7. After assembly is complete, hand over the product manual to the customer.
8. In case of a service request, identify the part by code.

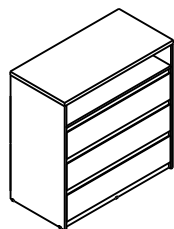
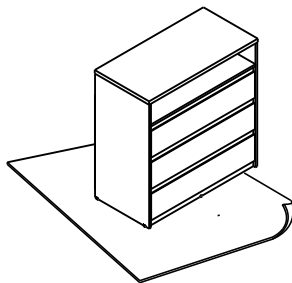

### Product information.

The product can be assembled standing or lying down following the step in the assembly instructions.  
The assembly system is in ascending order of the numbers indicated in the drawing. Ex.: 01 , 02 , 03..... until assembly is completed.

5

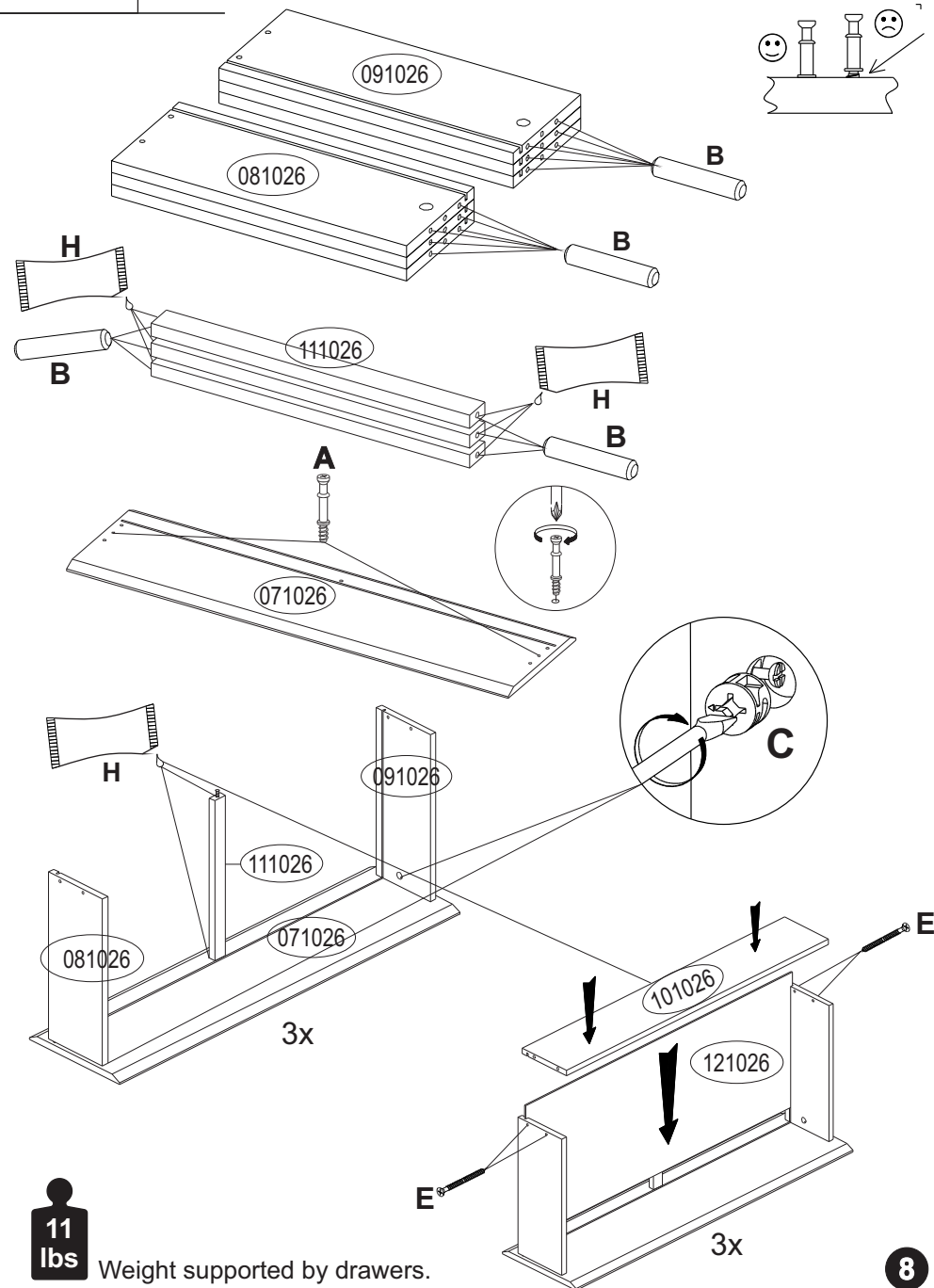

3

8

4

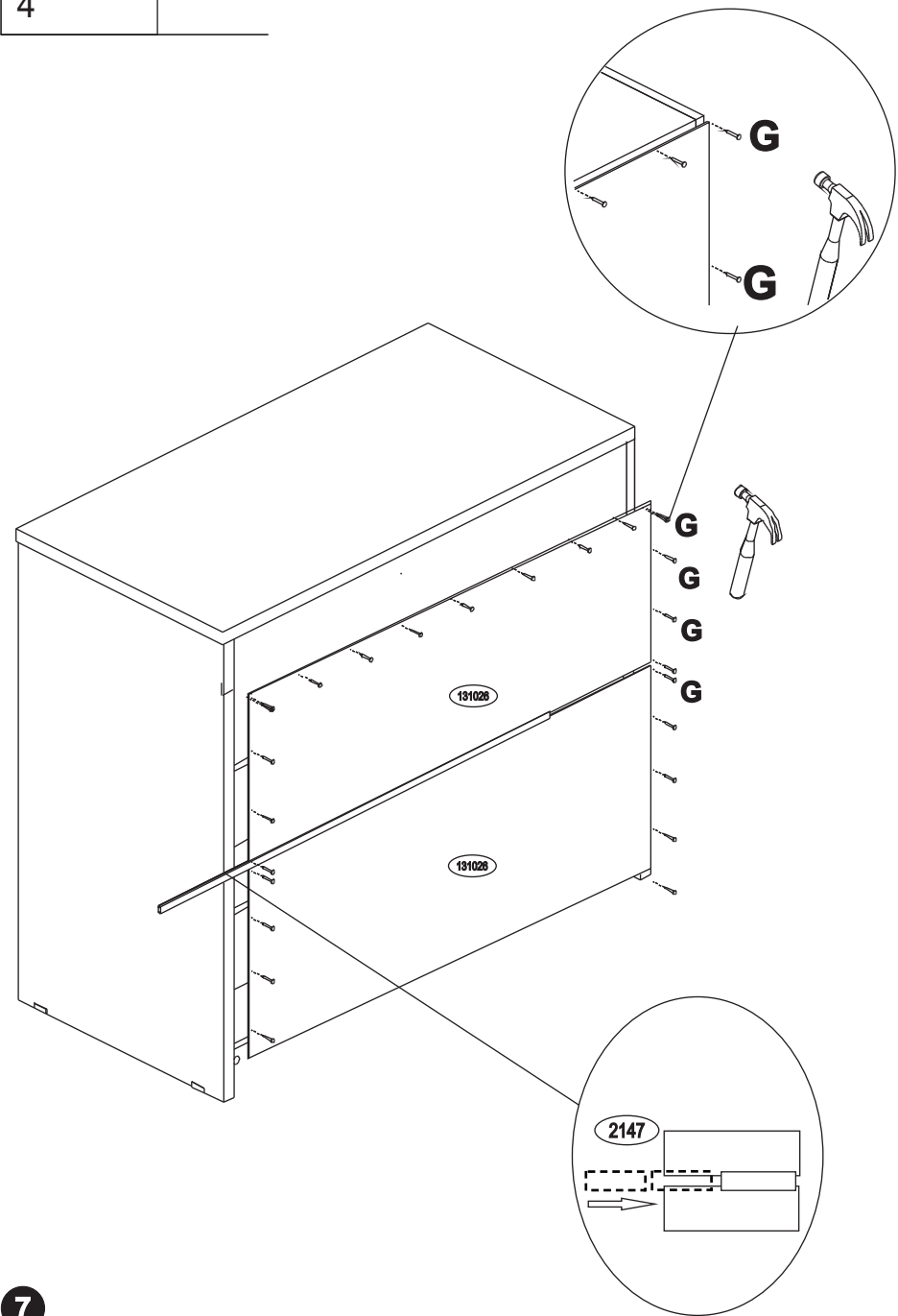

7

1

### Pre-Assembly

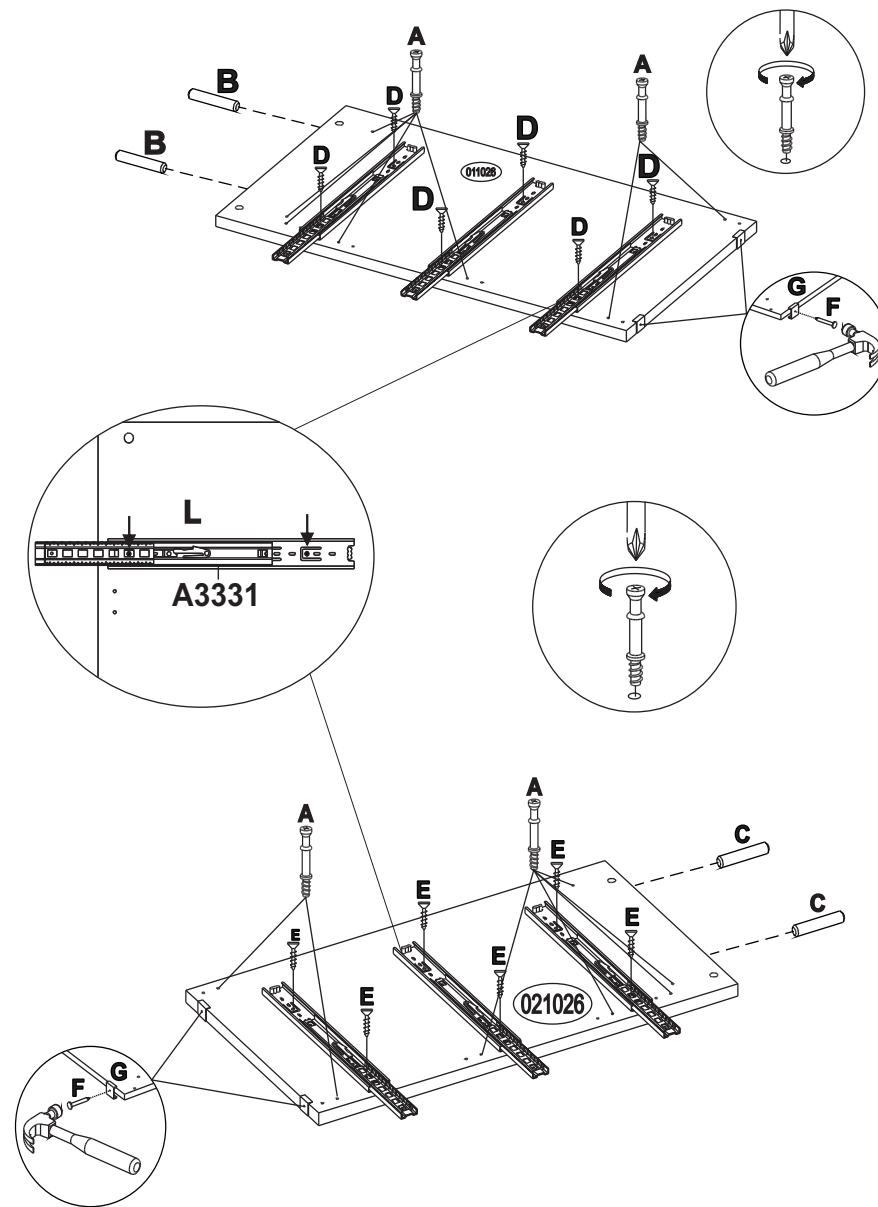

4

2

### Pre-Assembly

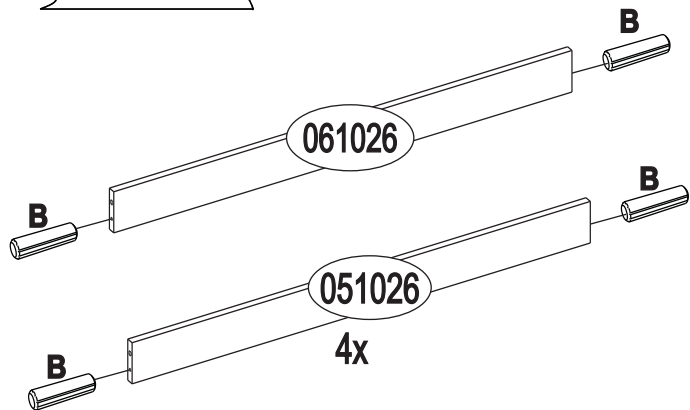
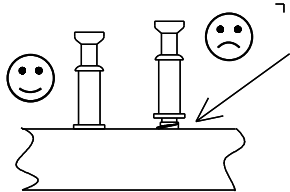
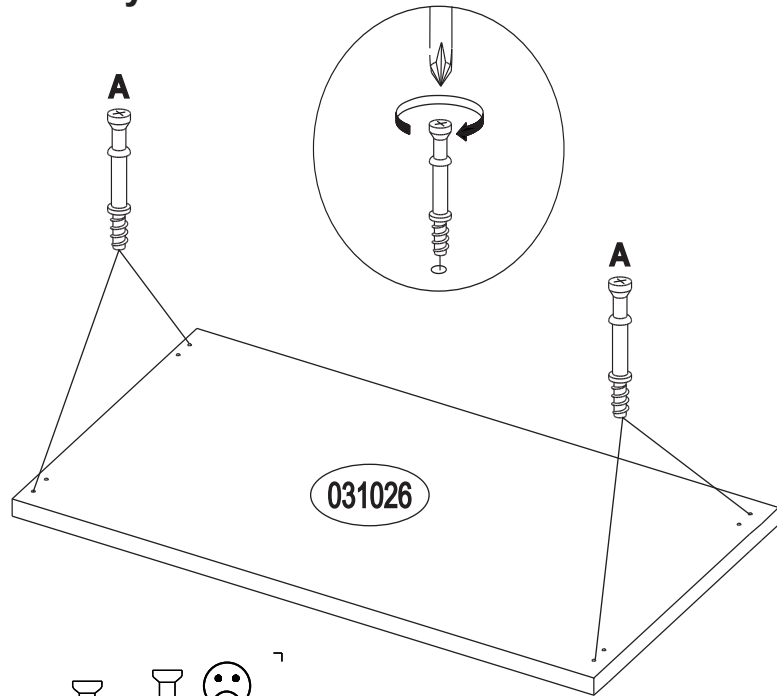

5

3

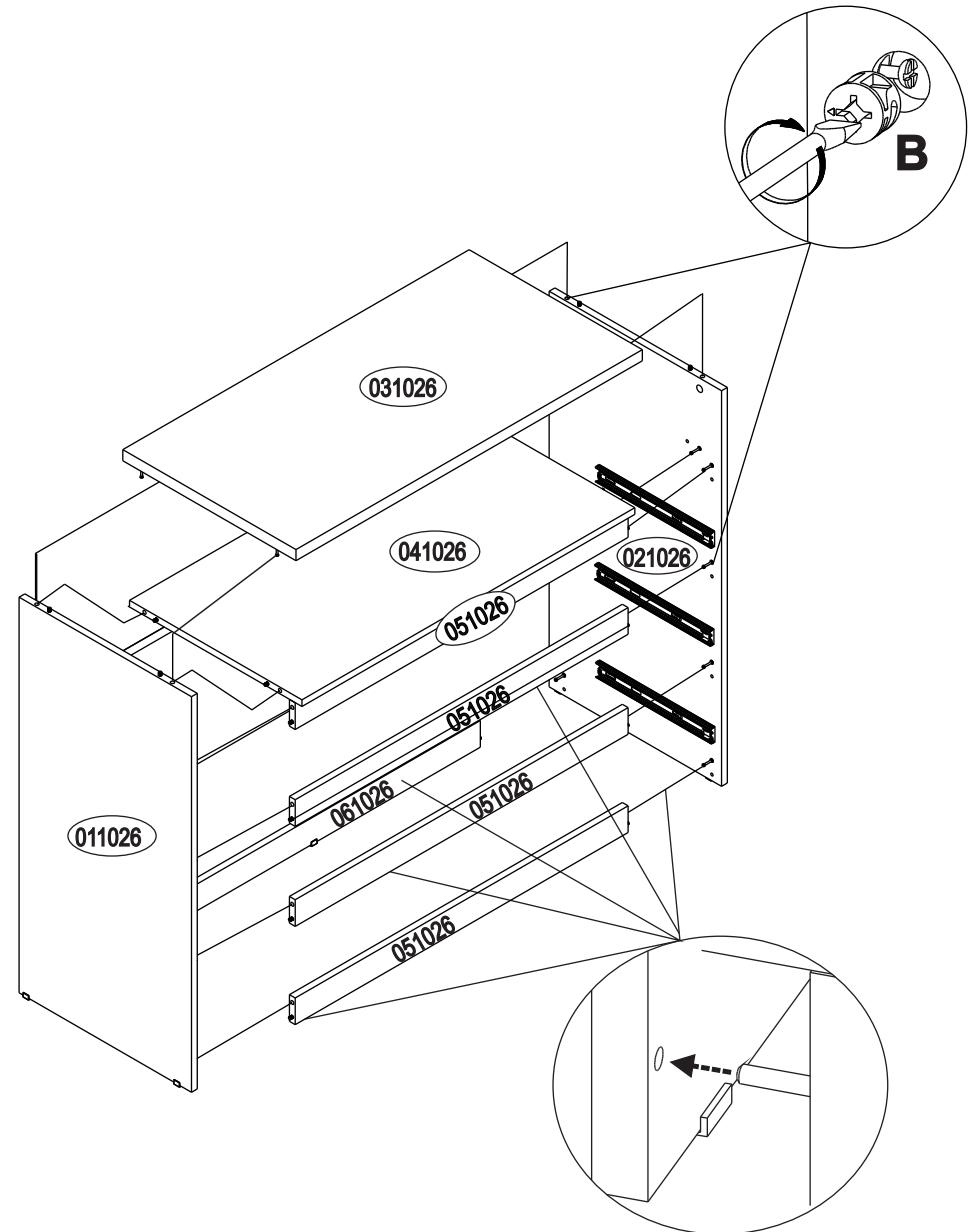

6