

ASSEMBLY INSTRUCTIONS

KING BED (4 + 8)

(BOX 1)

BOX OF HEADBOARD

NO	ITEM	QTY
A	Headboard	1
B	Headboard Leg (L&R)	2

(BOX 2)

BOX OF FOOTBOARD

NO	ITEM	QTY
C	Footboard	1
D	Slat	4
E	Slat support	8

(BOX 2)

BOX OF SIDE RAIL

NO	ITEM	QTY
F	Side Rail	2

(BOX 1)

HARDWARE LIST

NO	ITEM	QTY
1	JCBC BOLT M6 x 35MM	6 PCS
2	SPRING WASHER 1/4" RBW	6 PCS
3	FLAT WASHER 1/4" ID x 13mmOD BLK	6 PCS
4	ALLEN KEY M4 x 65MM	1 PCS
5	CSK SCREW M4 x 32MM RBW	8 PCS

STEP 1 : Attach Head Board Leg (B) to Head Board (A) as shown using JCBC BOLT (1) , Spring Washer (2) , Flat Washer (3) and securing with ALLEN KEY (4) .

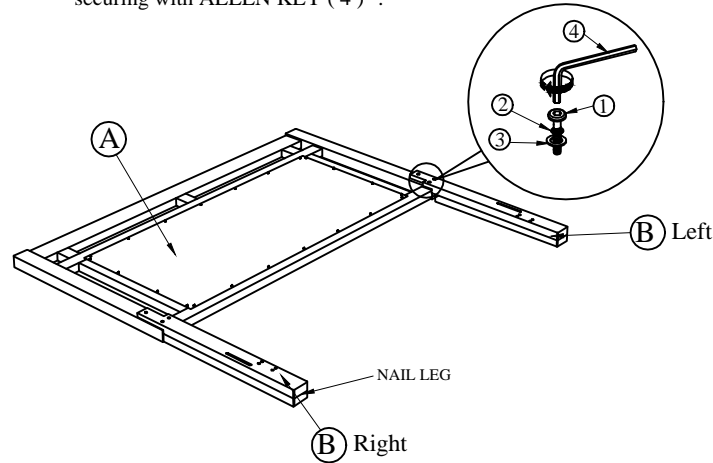

STEP 2 : Hook SIDE RAIL (F) TO HEAD BOARD (A) closely and push down to fit. repeat step 2 with other end of rail to hook onto FOOTBOARD (C).

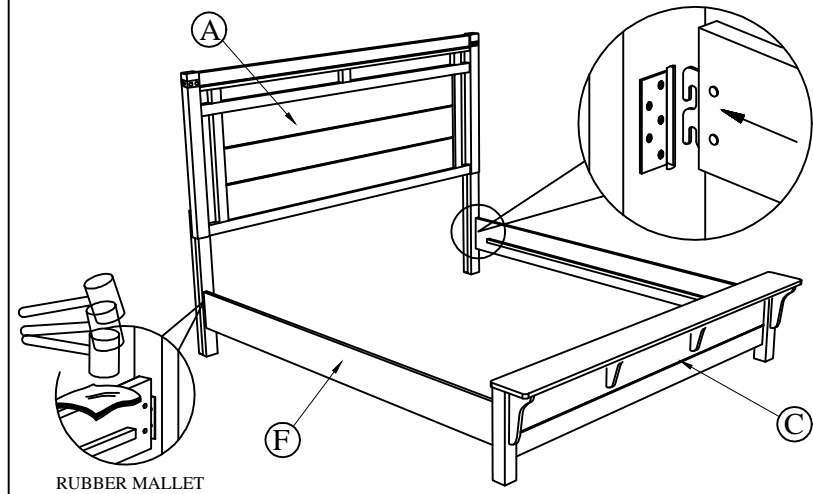

STEP 3 : Fix the Bed Slats Support (E) to Bed Slats (D) as Shown and fix the Bed Slats to Side Rail (F) by using Flat Head Chipboard Screw (5) . Loosen or Tighten the Adjuster as necessary to level the bed. Bed assembly should be done in final location to ensure stability.

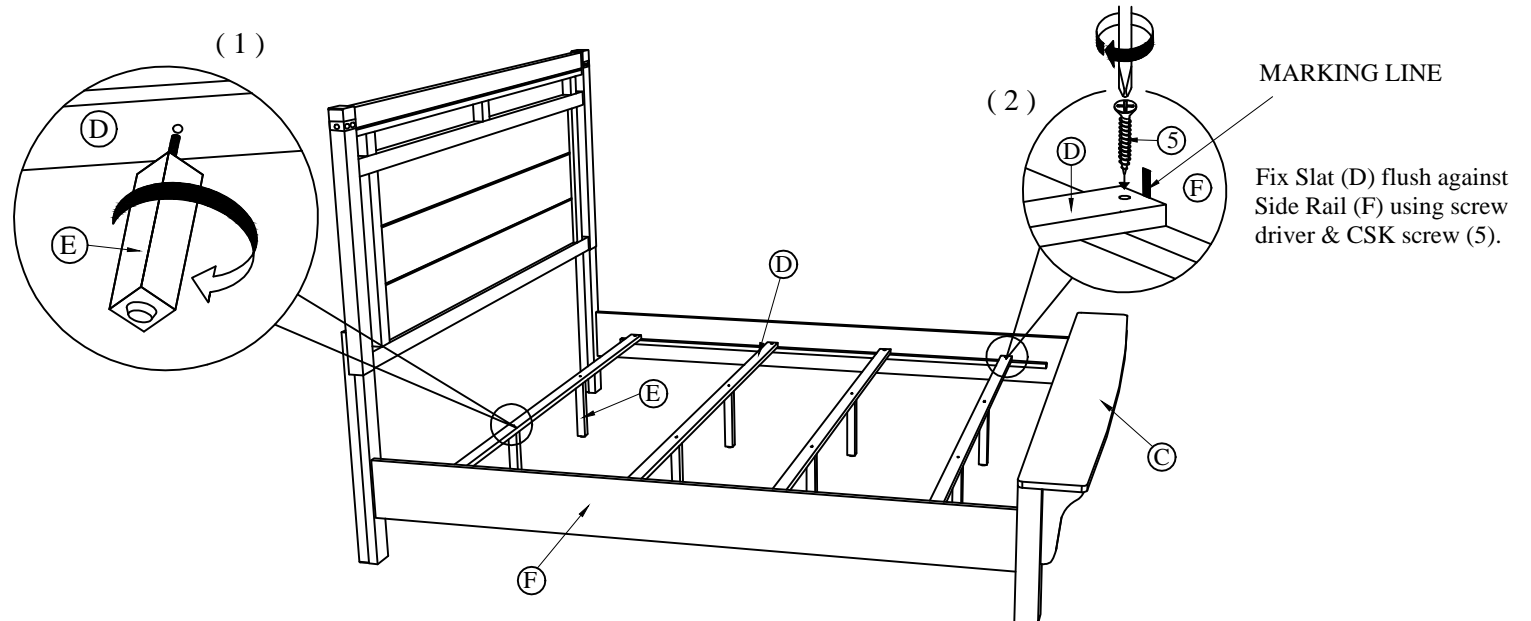

NOTE : MUST TIGHTEN SCREWS PERIODCALLY WITH USE SCREW WILL BECOME LOOSE CHECK TIGHTNESS OF ALL SCREW EVERY 6-8 WEEKS.