

Assembly Instructions

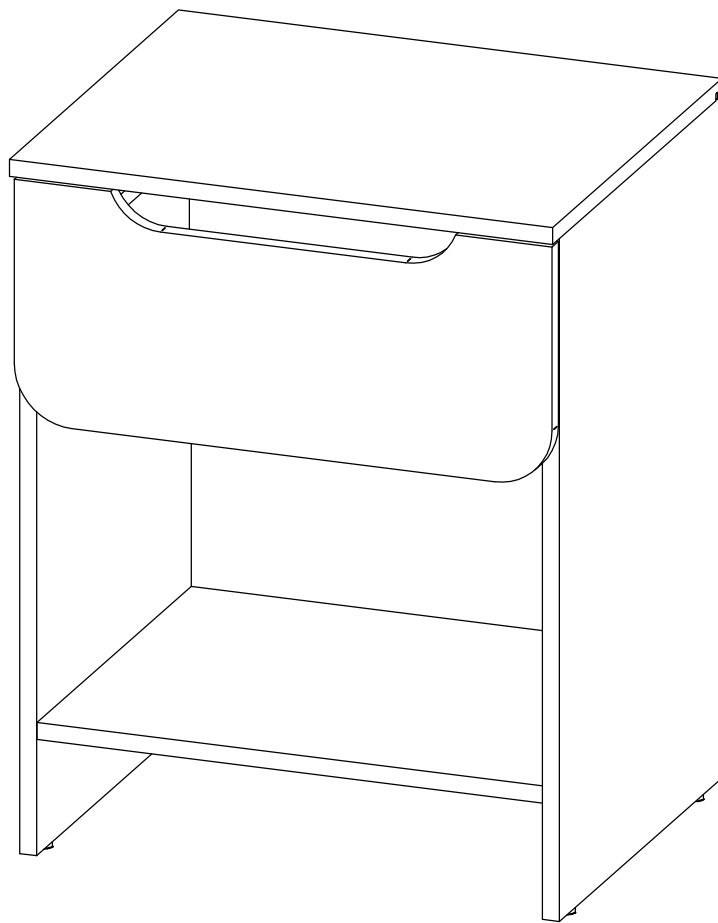

General Assembly Guidelines

- I. Ensure that all parts and hardware are available before beginning assembly.
- II. Follow each step carefully to ensure the proper assembly of this product.
- III. Two people are recommended for ease in the assembly of this product.
- IV. The two main types of hardware used to assemble this product are: wood dowels and screws.
- V. A Phillips head screwdriver is required for the assembly of this product (not included)

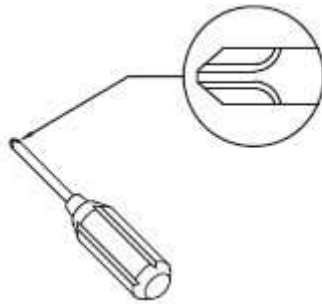



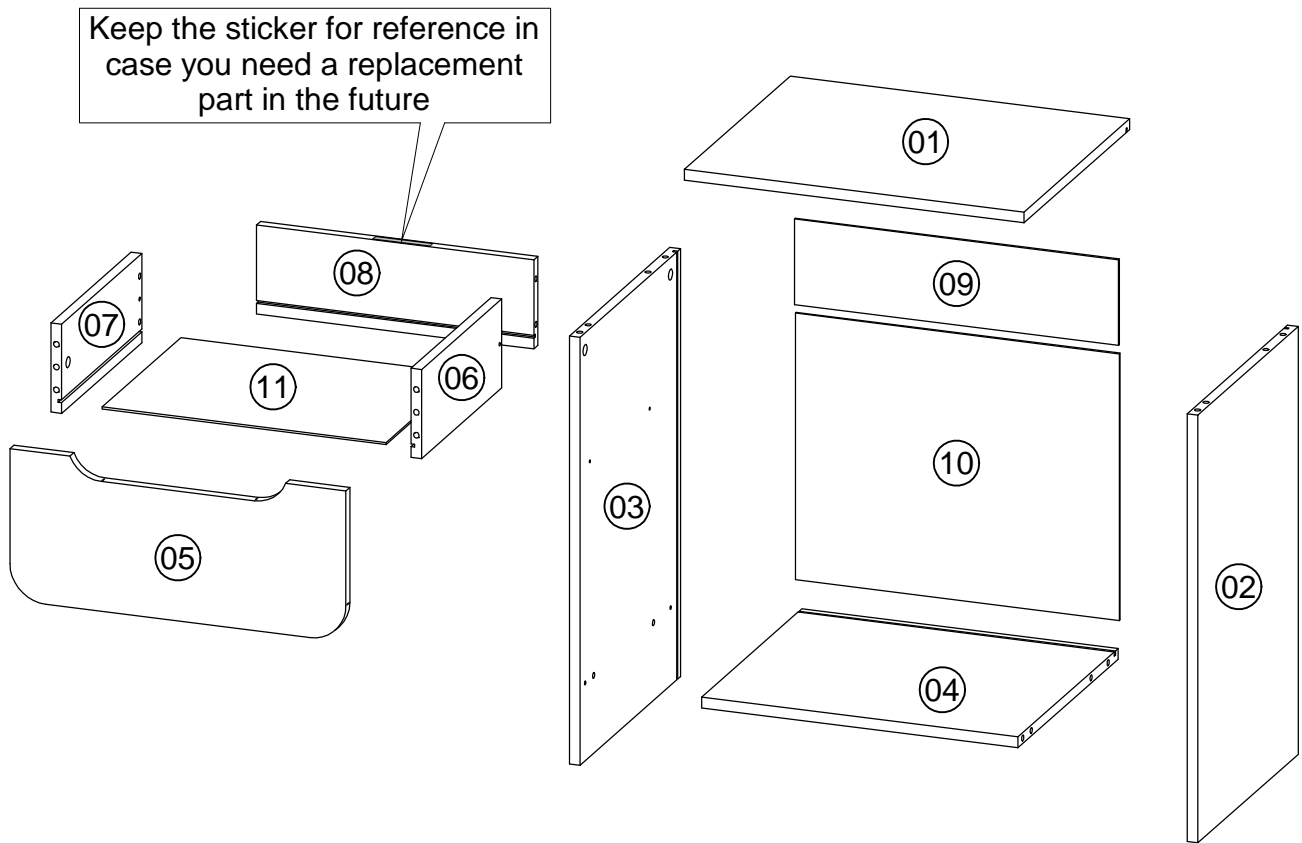



Parts List

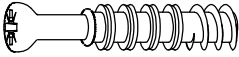

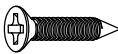
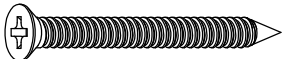
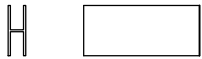
Part #	Description	Qty
01	Top Panel	1
02	Right Side Panel	1
03	Left Side Panel	1
04	Bottom Panel	1
05	Drawer Front	1
06	Right Drawer Side	1
07	Left Drawer Side	1
08	Drawer Back	1
09	Smaller Back Panel	1
10	Larger Back Panel	1
11	Drawer Bottom	1

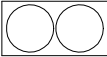
Hardware List

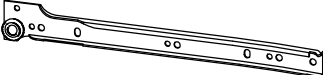
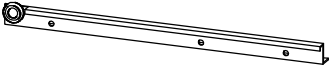
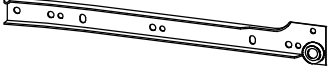
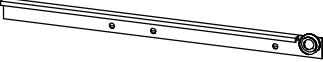
A		Ø8x30	Wooden Dowel	16 pcs
B		Ø6x31mm	Cam Bolt	10 pcs
C		Ø15x10mm	Cam Lock	10 pcs
D		Ø3,5x14mm	Screw	12 pcs
E		Ø3x16mm	Screw	6 pcs
F		Ø4x40mm	Screw	2 pcs
G		447mm	Profile	1 pcs
H		14x14mm	Support	6 pcs
I		Ø 19mm	Sticker	2 pcs
J		Ø14x4mm	Plastic foot	4 pcs
L1		300mm	Slider	1 pcs
L2		300mm	Slider	1 pcs
R1		300mm	Slider	1 pcs
R2		300mm	Slider	1 pcs

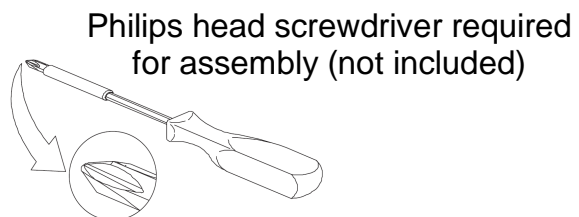
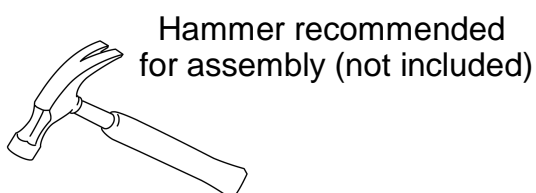

*The hardware quantities listed above are required for proper assembly.
Some extra hardware may also have been included.*

Step 1

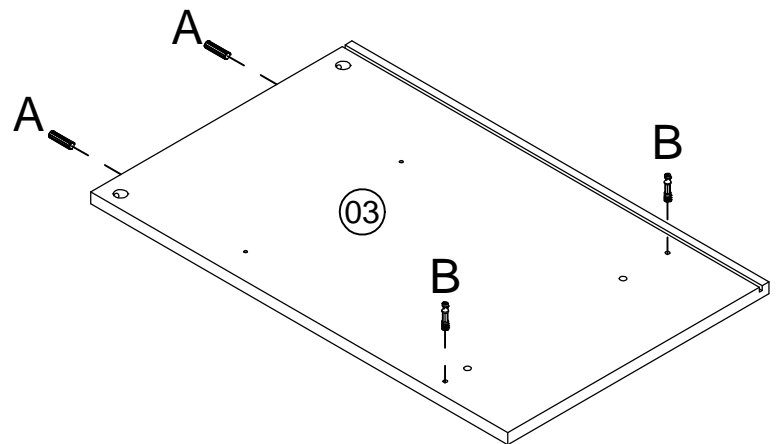
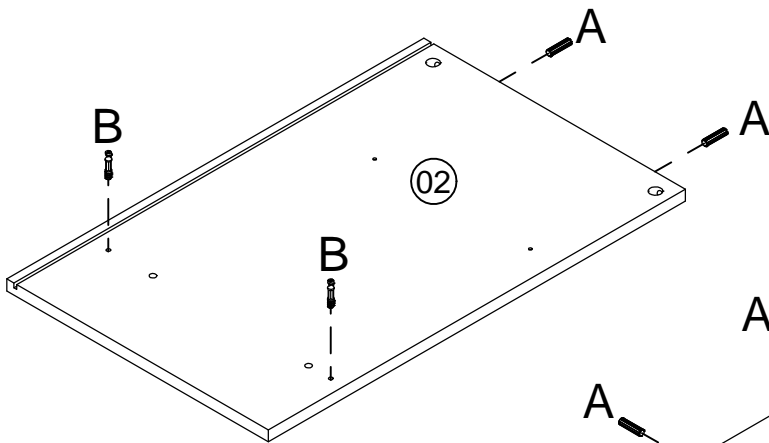
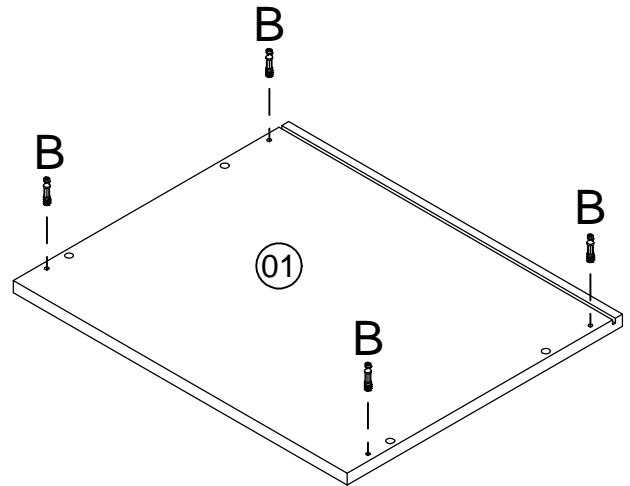
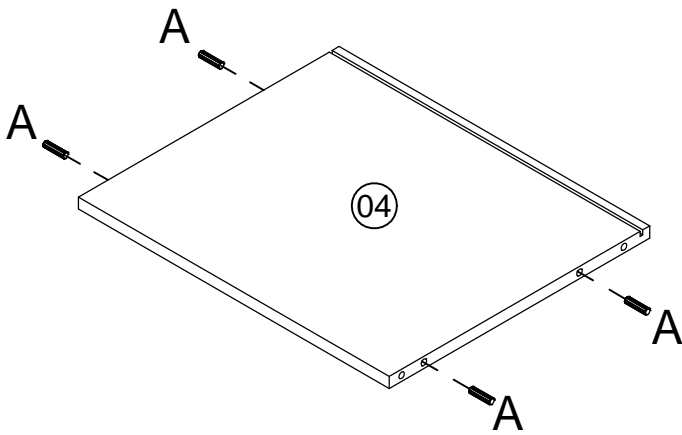

Please assemble on a clean soft surface to avoid damage.

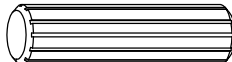
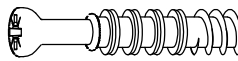

Insert wooden dowel (A) to parts (2,3,4) and insert cam bolt (B) to parts (1,2,3).

A	 $\varnothing 8 \times 30$	8
B	 $\varnothing 6 \times 31 \text{mm}$	8

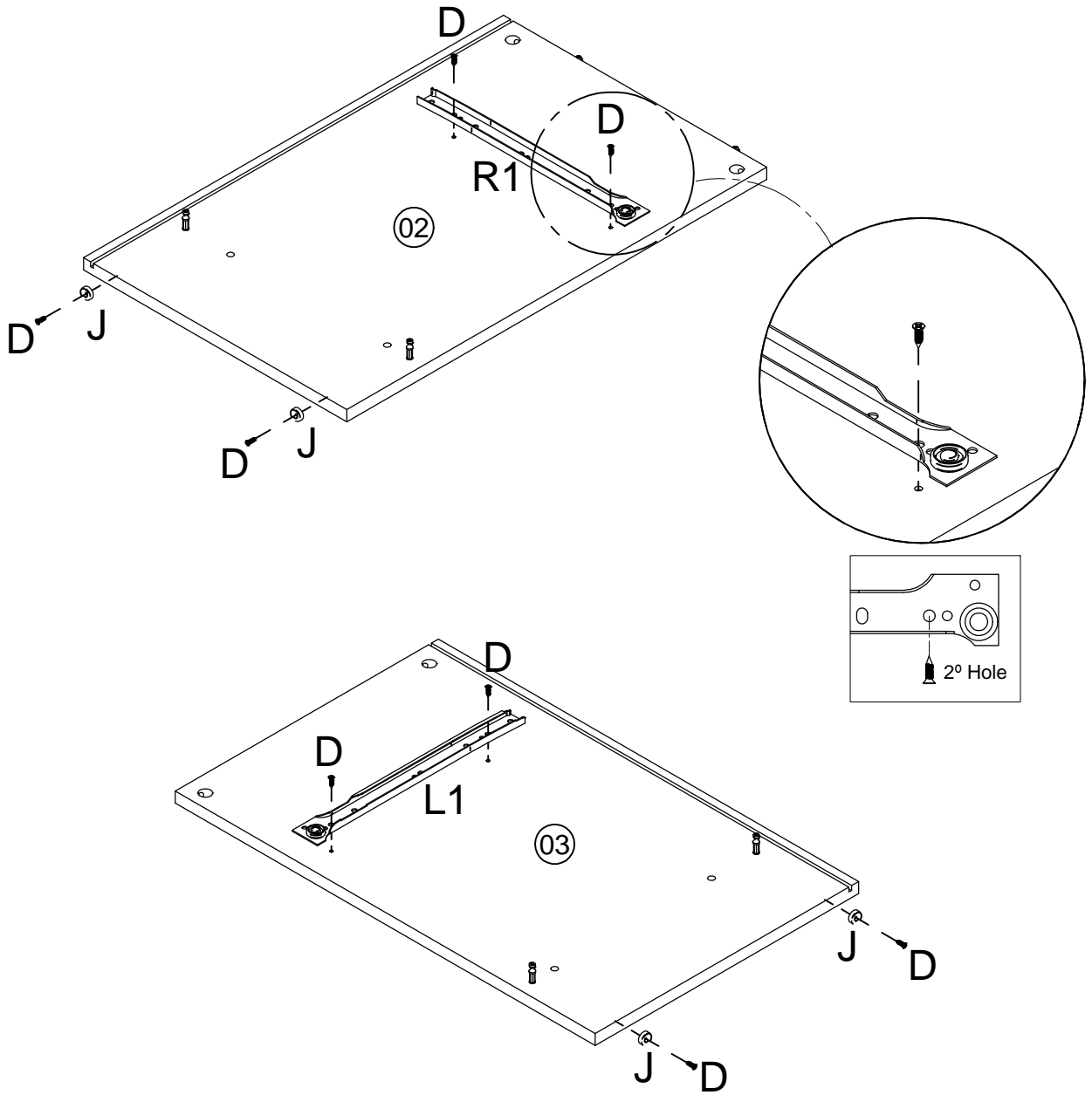

Step 2



Please assemble on a clean soft surface to avoid damage.

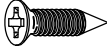

Attach slides (L1,R1) to parts (2,3) with screw (D) and attach plastic foot (J) to parts (2,3) with screw (D).

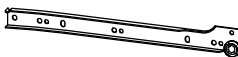
D		Ø3,5x14mm	8
J		Ø14x4mm	4
L1		300mm	1
R1		300mm	1

Step 3

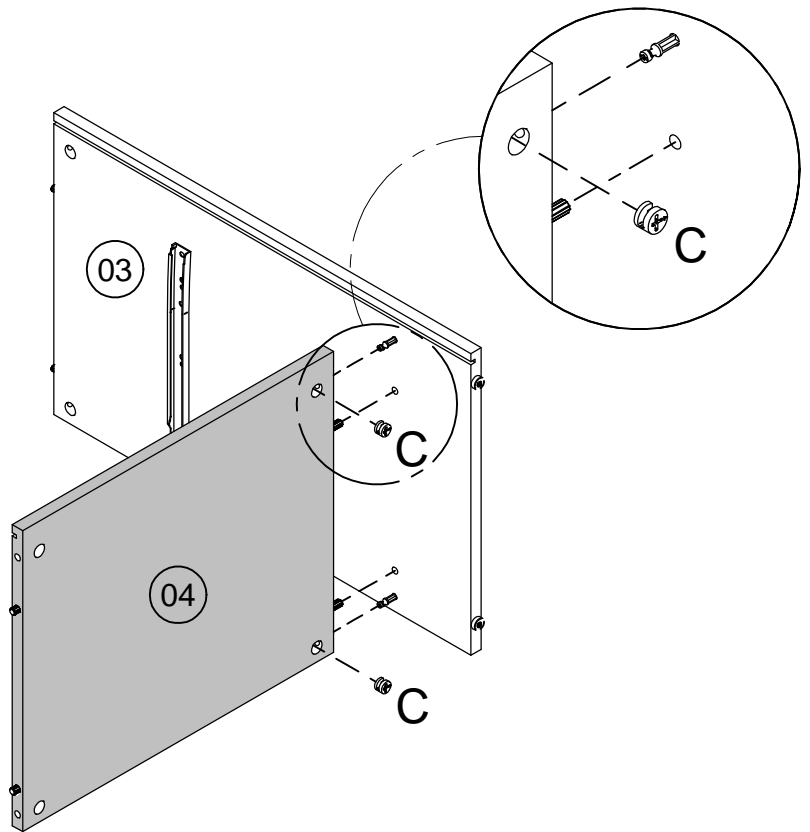
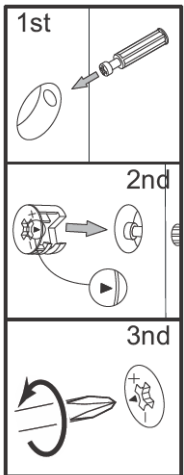

Secure part (4) to part (3) using cam lock (C) as per diagram.

C		Ø15x10mm	2
----------	--	----------	---

Step 4

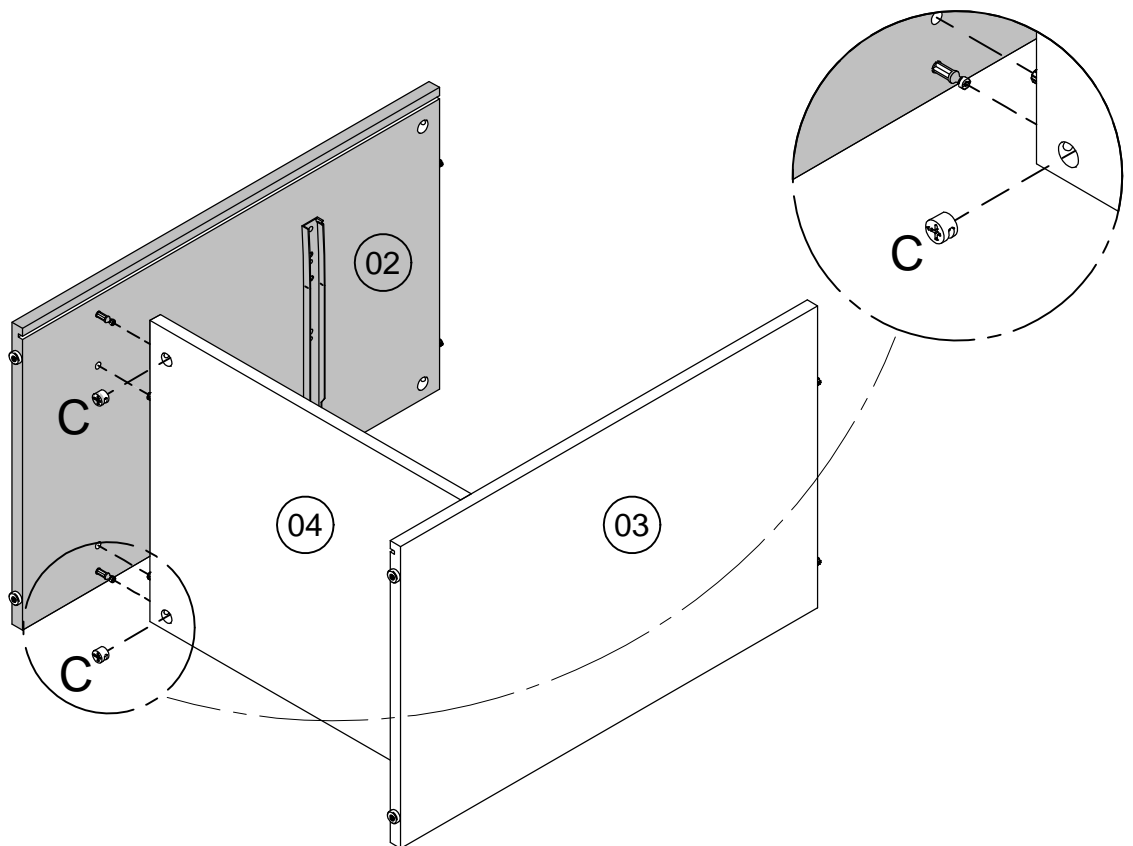
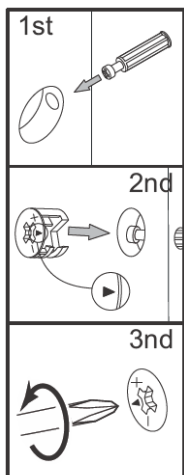

Secure parts (3,4) to part (2) using cam lock (C) as per diagram.

C		Ø15x10mm	2
----------	---	----------	---

Step 5

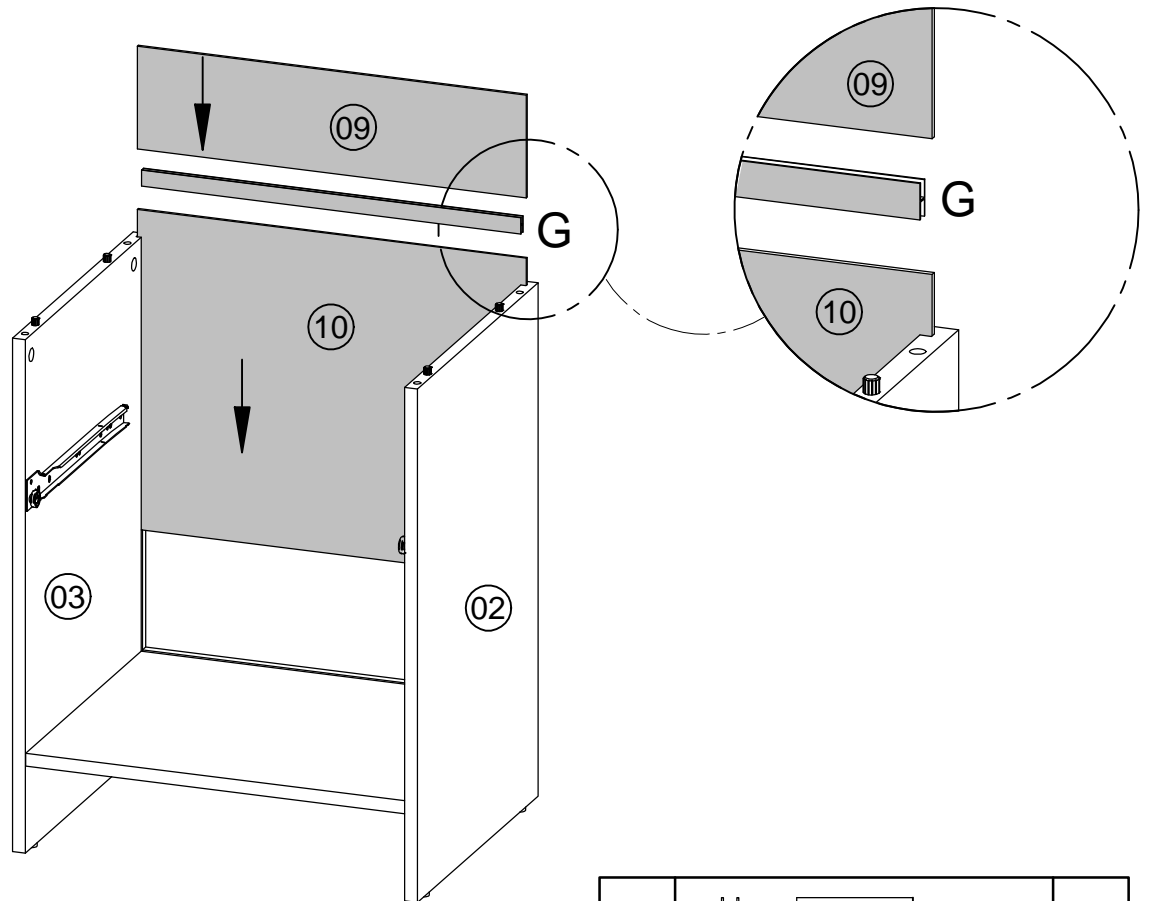

Slide back panels (9,10) and part (G) into side panel (2,3).

G		447mm	1
----------	--	-------	---

Step 6

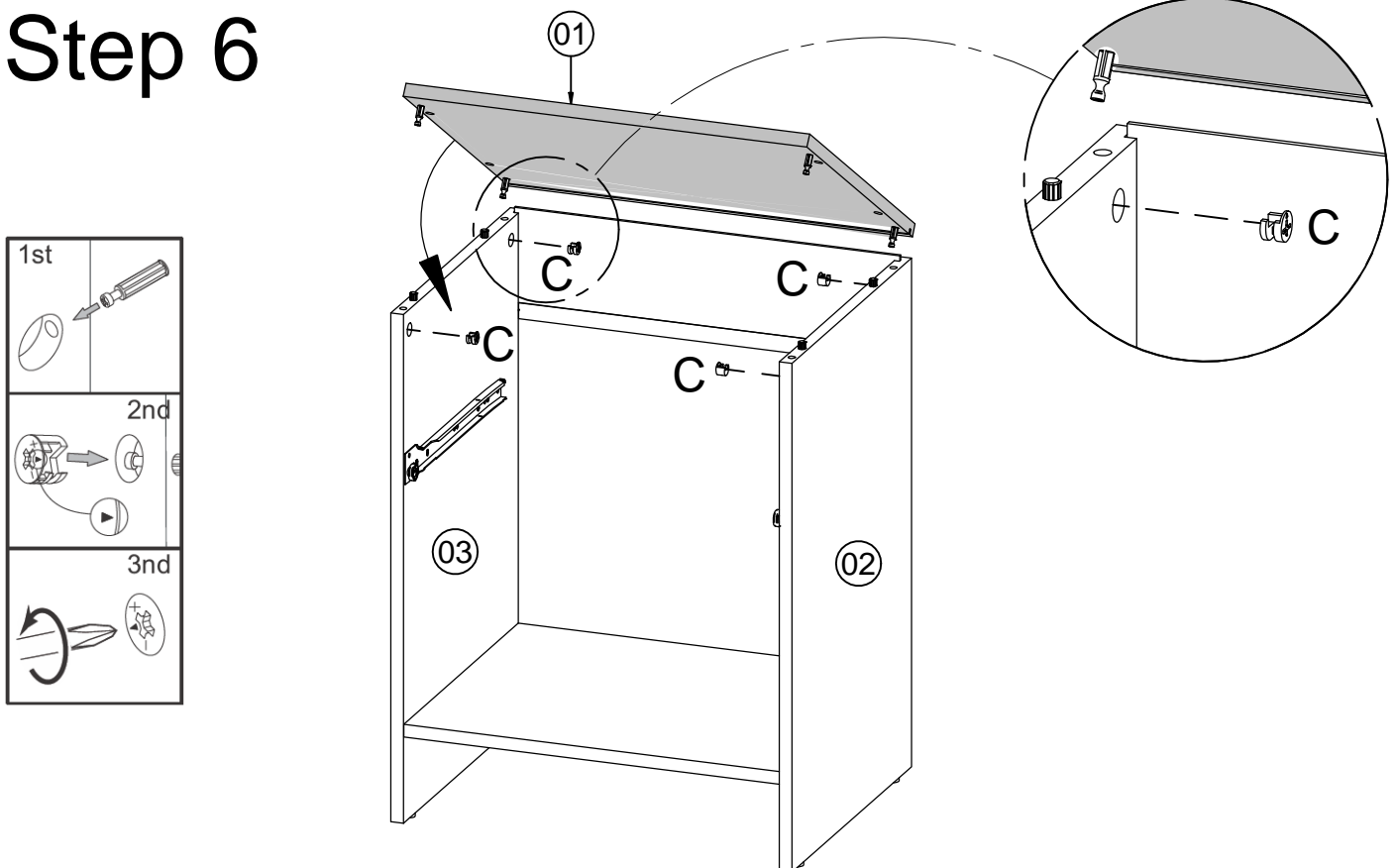



Secure part (1) to parts (2,3) using cam lock (C).

C		Ø15x10mm	4
----------	--	----------	---

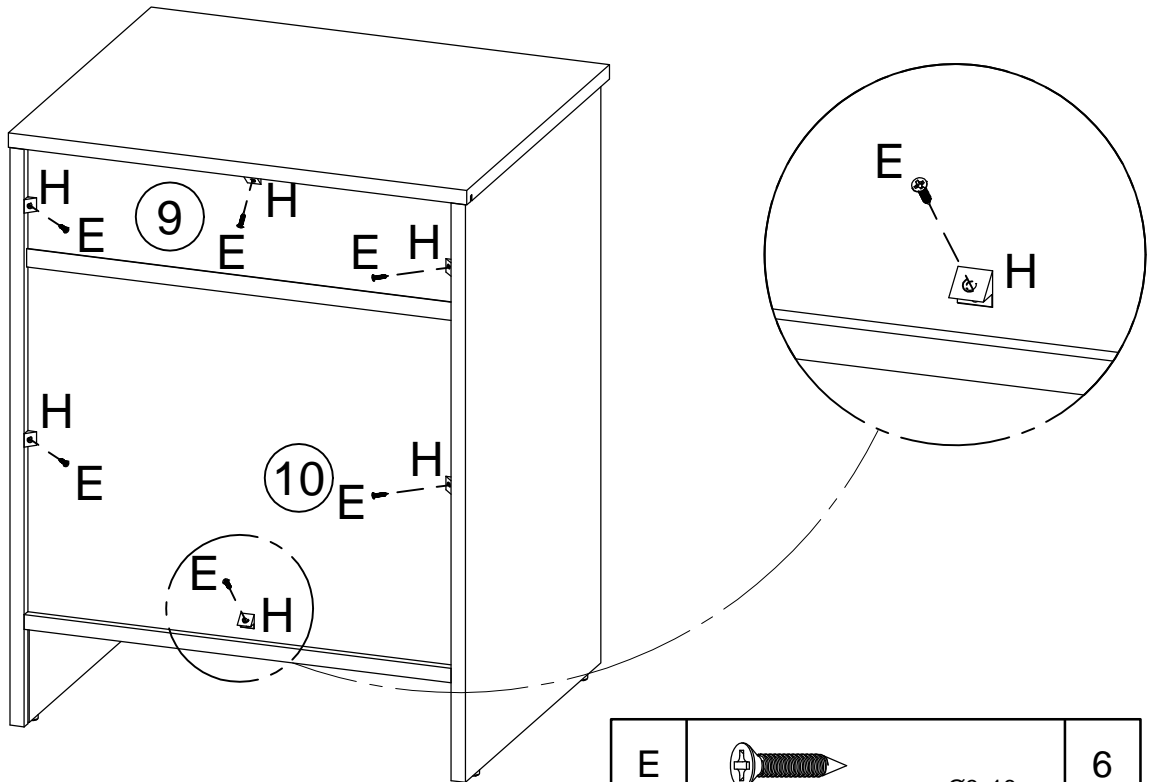
Step 7

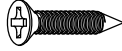

Secure back panels (9,10) using screw (E) and support (H).

E		Ø3x16mm	6
H		14x14mm	6

Step 8

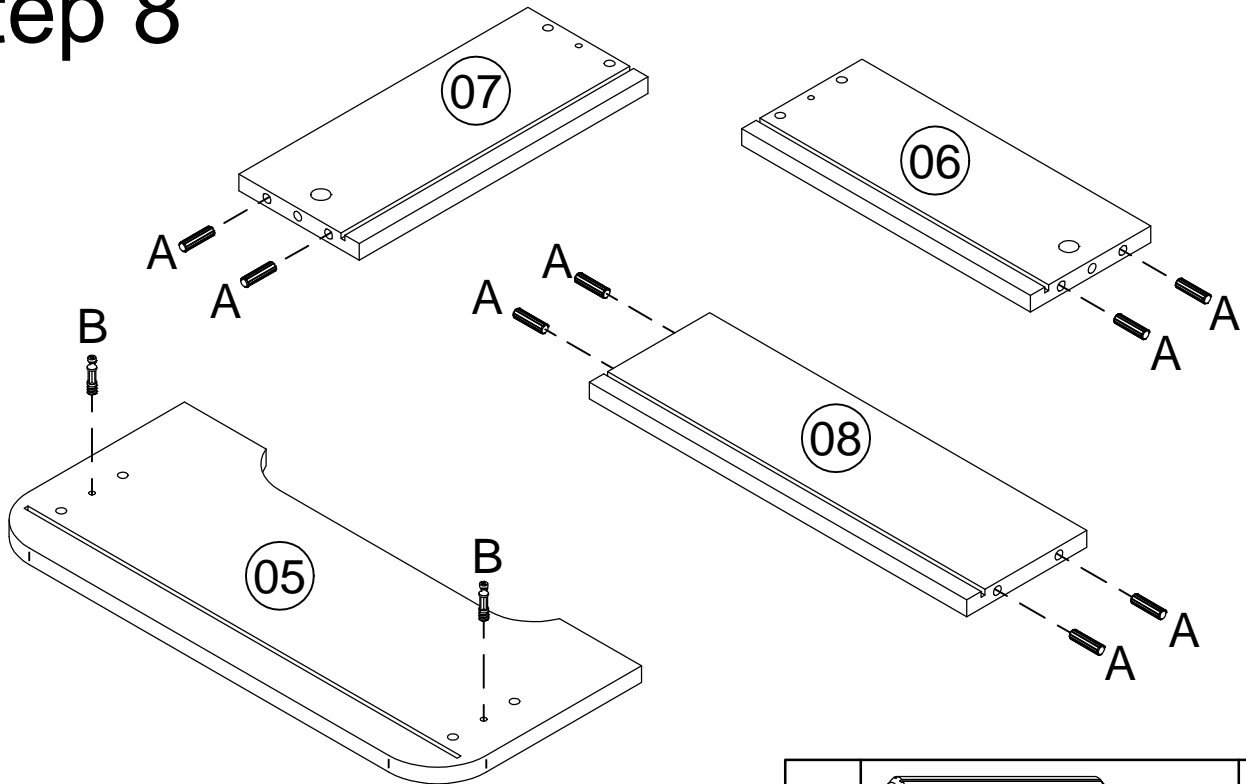

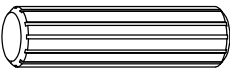
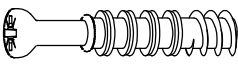

Insert wooden dowel (A) to parts (6,7,8) and insert cam bolt (B) to part (5).

A		Ø8x30	8
B		Ø6x31mm	2

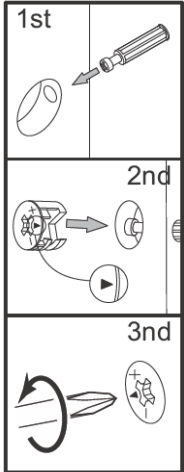
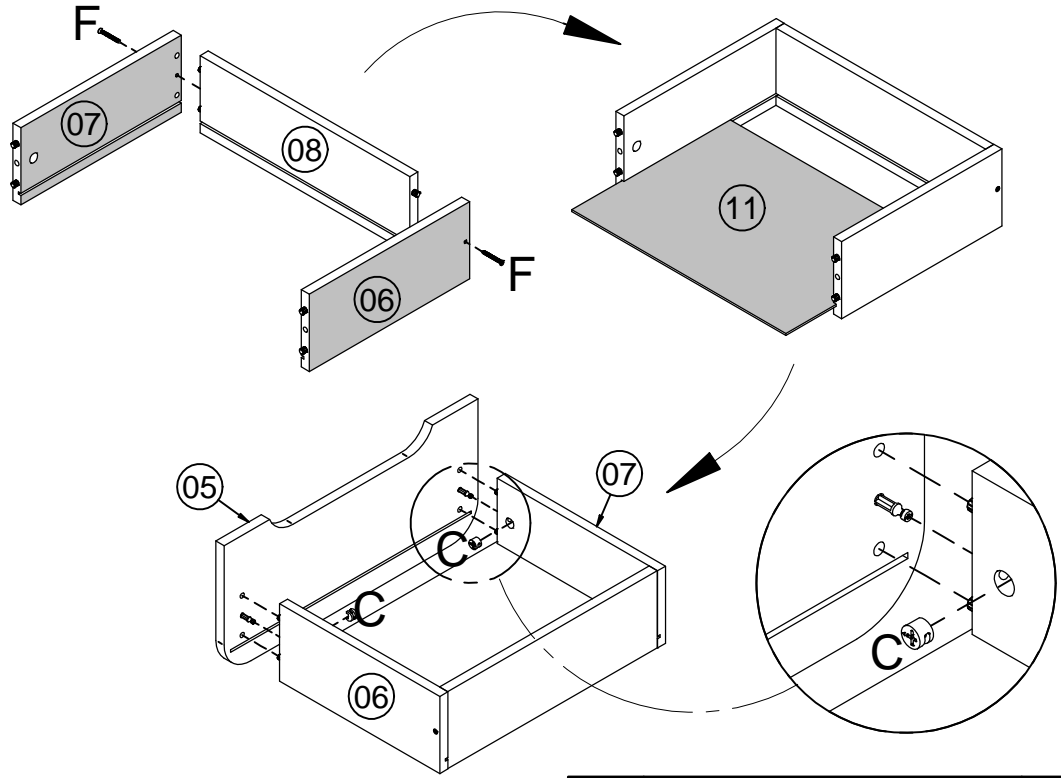
Step 9



Secure parts (6,7) to part (8) using screw (F).
Secure part (5) to parts (6,7) using cam lock (G).

C		Ø15x10mm	2
F		Ø4x40mm	2

Step 10

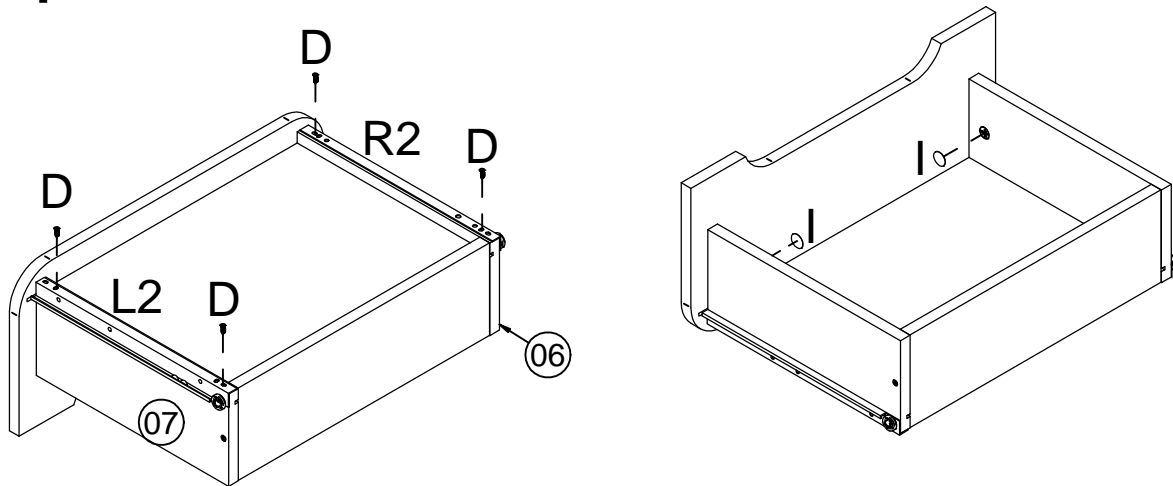

Attach slides (L2,R2) to parts (6,7) with screw (D). Place sticker (I) over holes as per diagram.

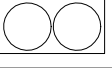
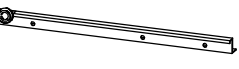
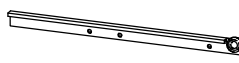
D		Ø3,5x14mm	4
I		Ø 19mm	2
L2		300mm	1
R2		300mm	1

Step 11

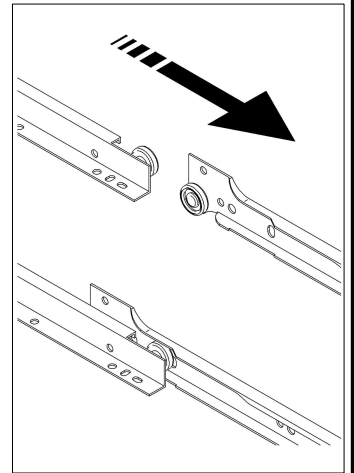
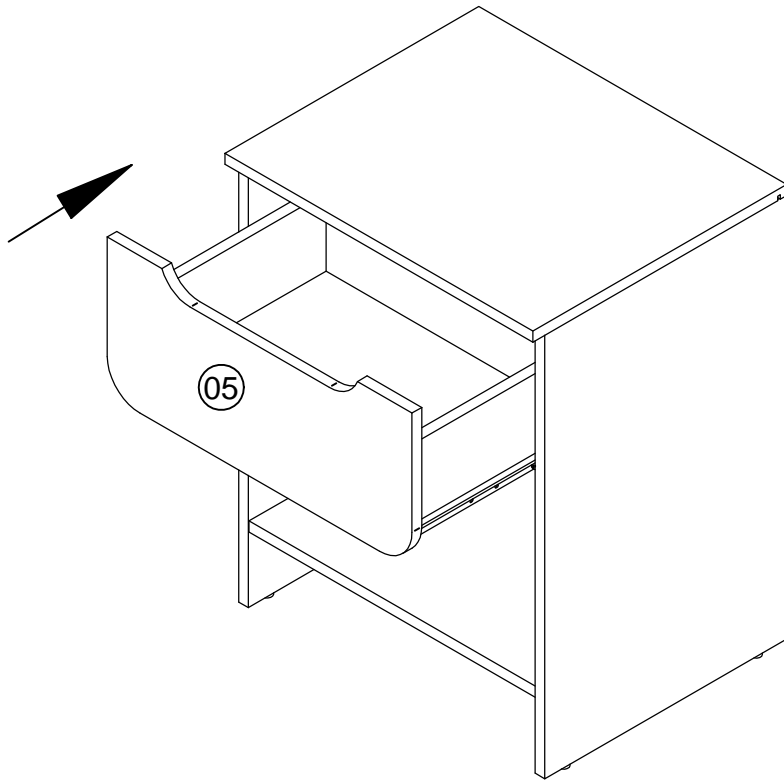

Step 12

