

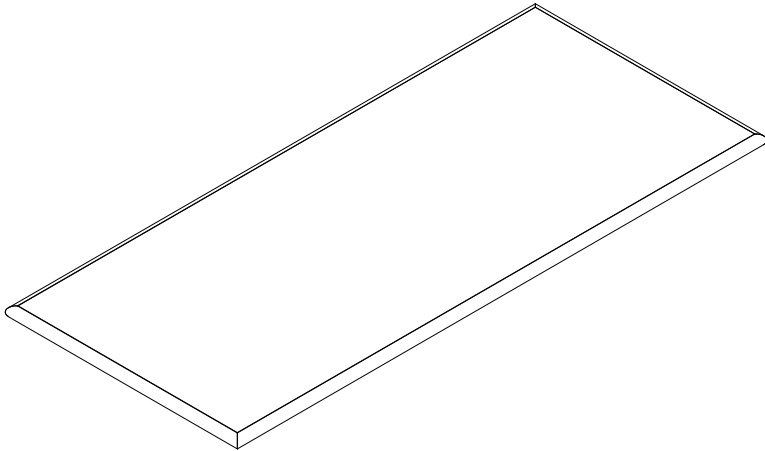

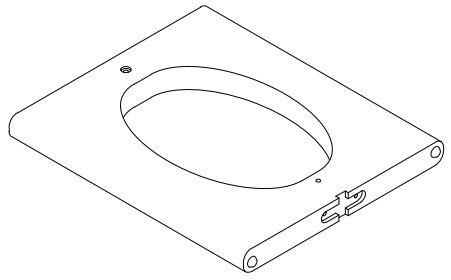







CVFVRD334-ASSEMBLY INSTRUCTIONS

PARTS LIST

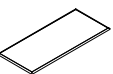
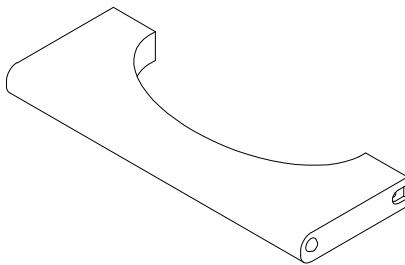
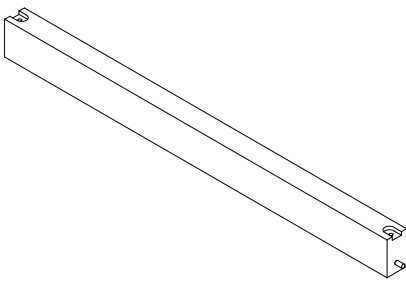
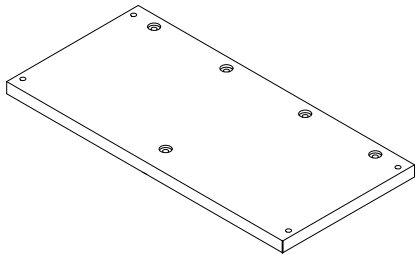
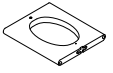
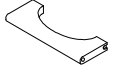
No	Hardware List		Q'ty	A		B	
1		Bolt 5/16"x40mm	26				
2		Bolt 5/16"x80mm	2				
3		Lock washer 5/16"	28				
4		Flat washer 5/16" x 19 x 2mm	28				
5		Allen key 4mm	1				
6		Metal Plate 150 x 150 x 2mm	2				
No	Part List		Q'ty	C	D	E	
A		Table Top	1				
B		Leg B	2				
C		Leg C	2				
D		Stretcher	1				
E		Mounting Plate	2				

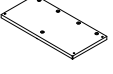

CVFVRD334-ASSEMBLY INSTRUCTIONS

Step 1

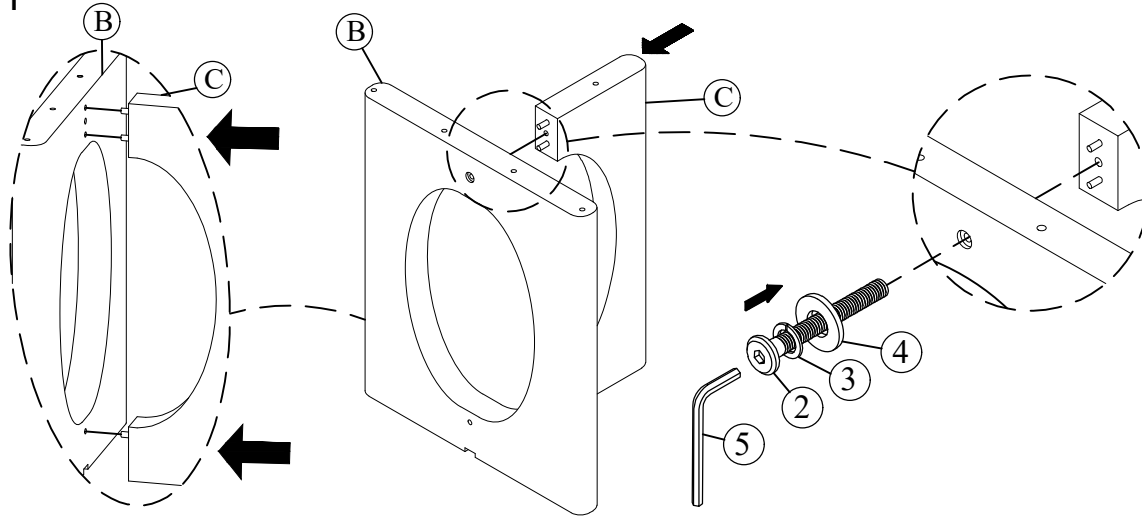

Step 3

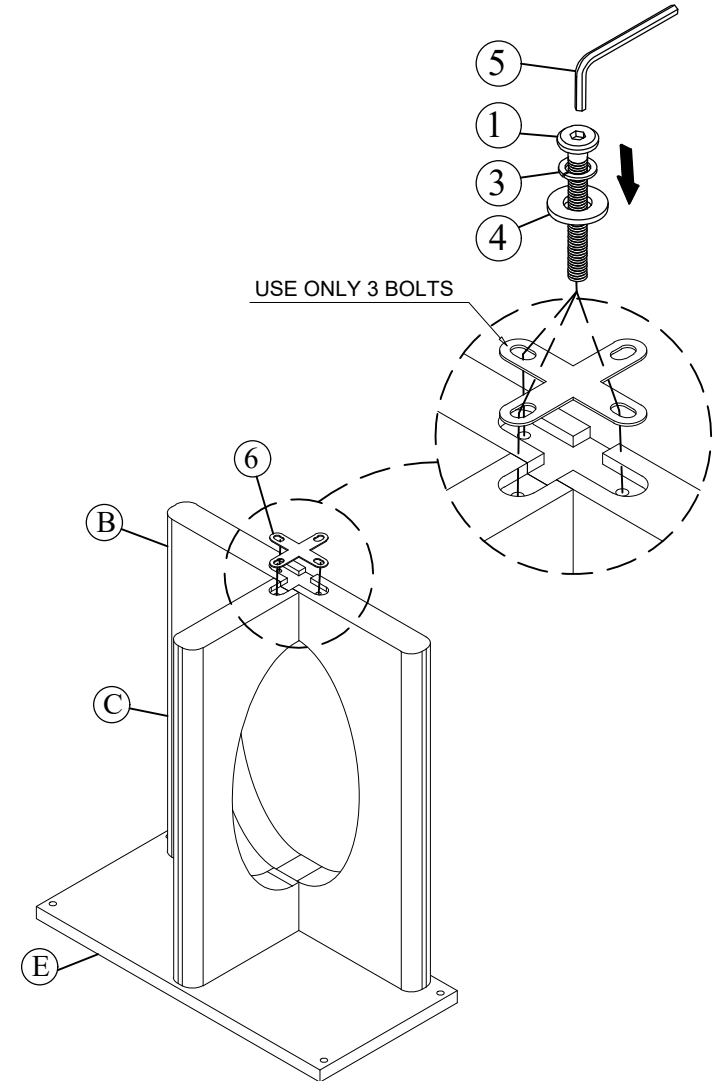

Step 2

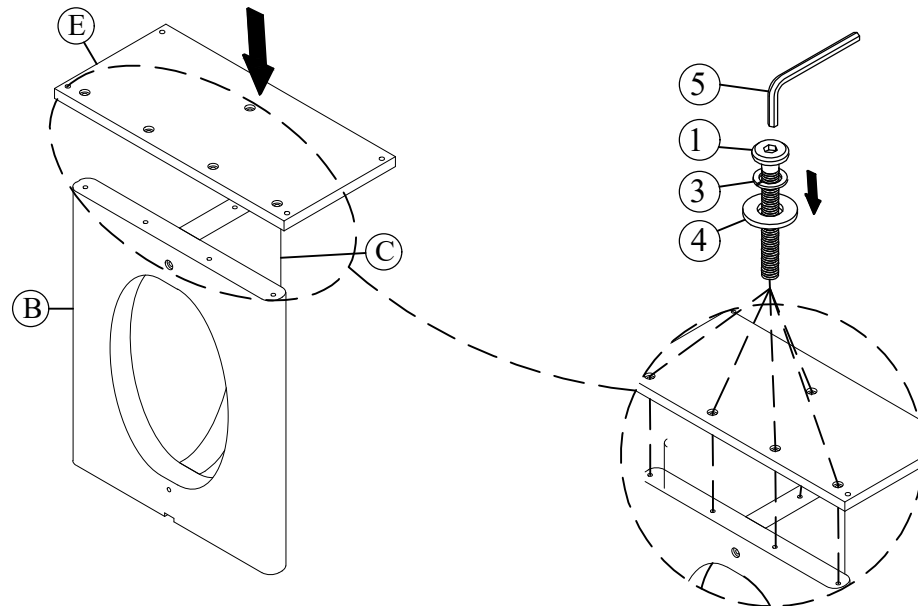

PLEASE TIGHTEN BOLTS



CVFVRD334-ASSEMBLY INSTRUCTIONS

Step 4

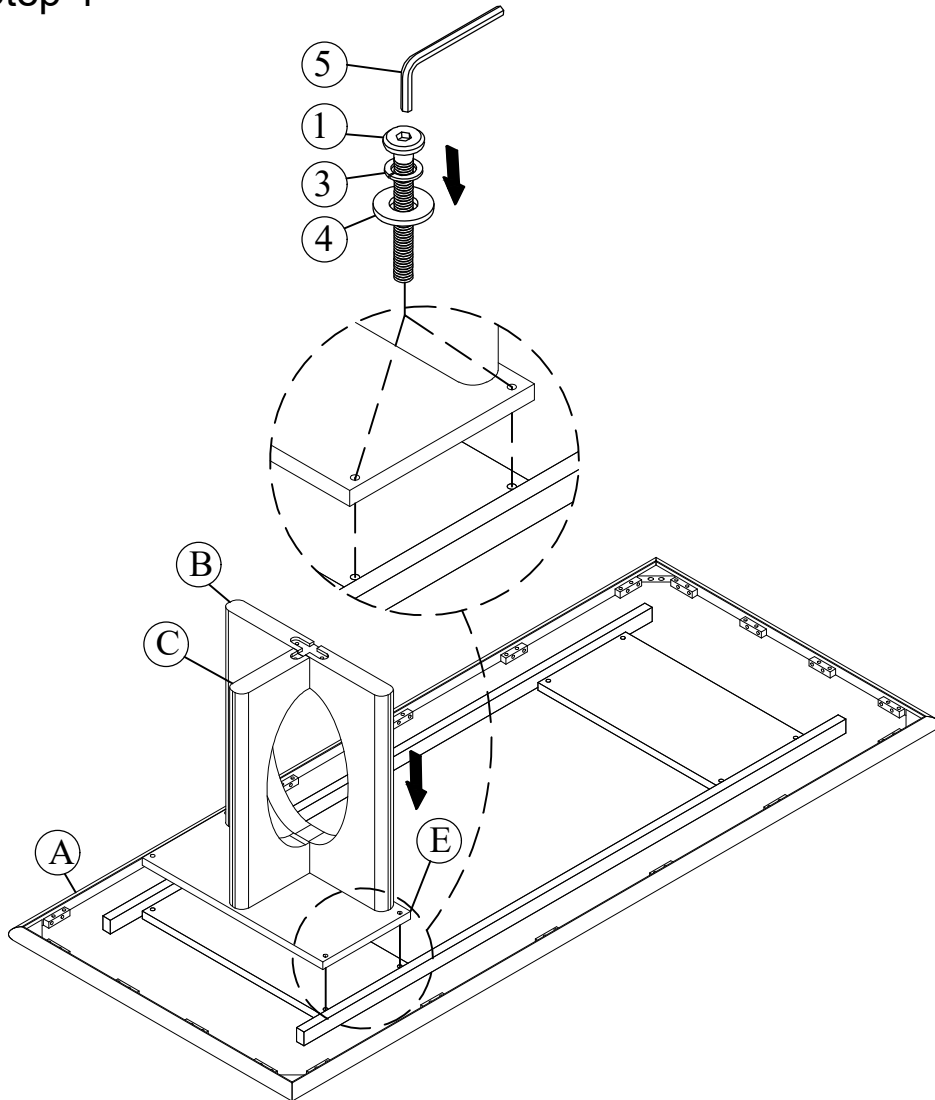

DON'T TIGHTEN THE BOLTS UNTIL PUT THE REST OF BASE WITH STRETCHER TOGETHER

Step 5

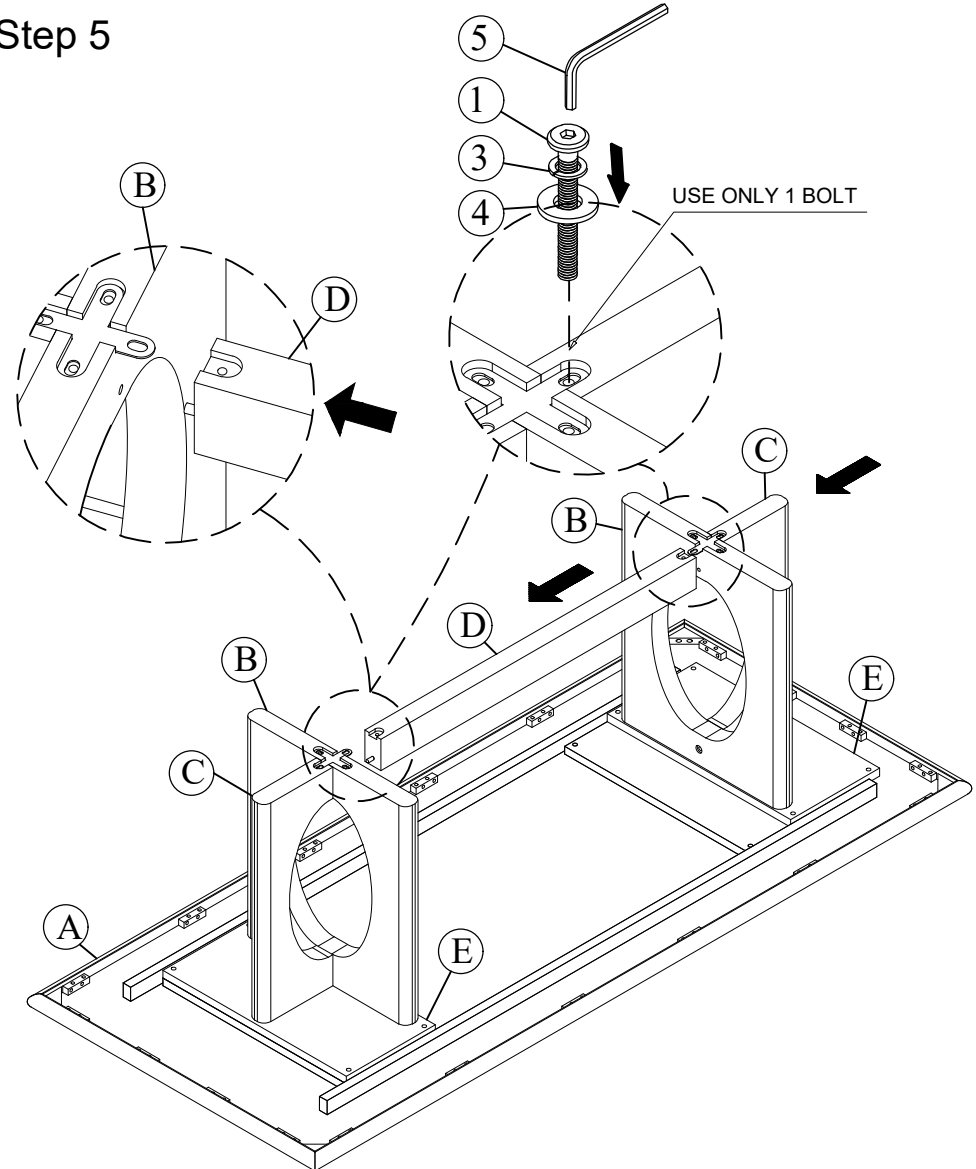

PLEASE PUT THE STRETCHER AND THE SECOND LEG FRAME AT THE SAME TIME PLEASE TIGHTEN BOLTS



CVFVRD334-ASSEMBLY INSTRUCTIONS

Step 6

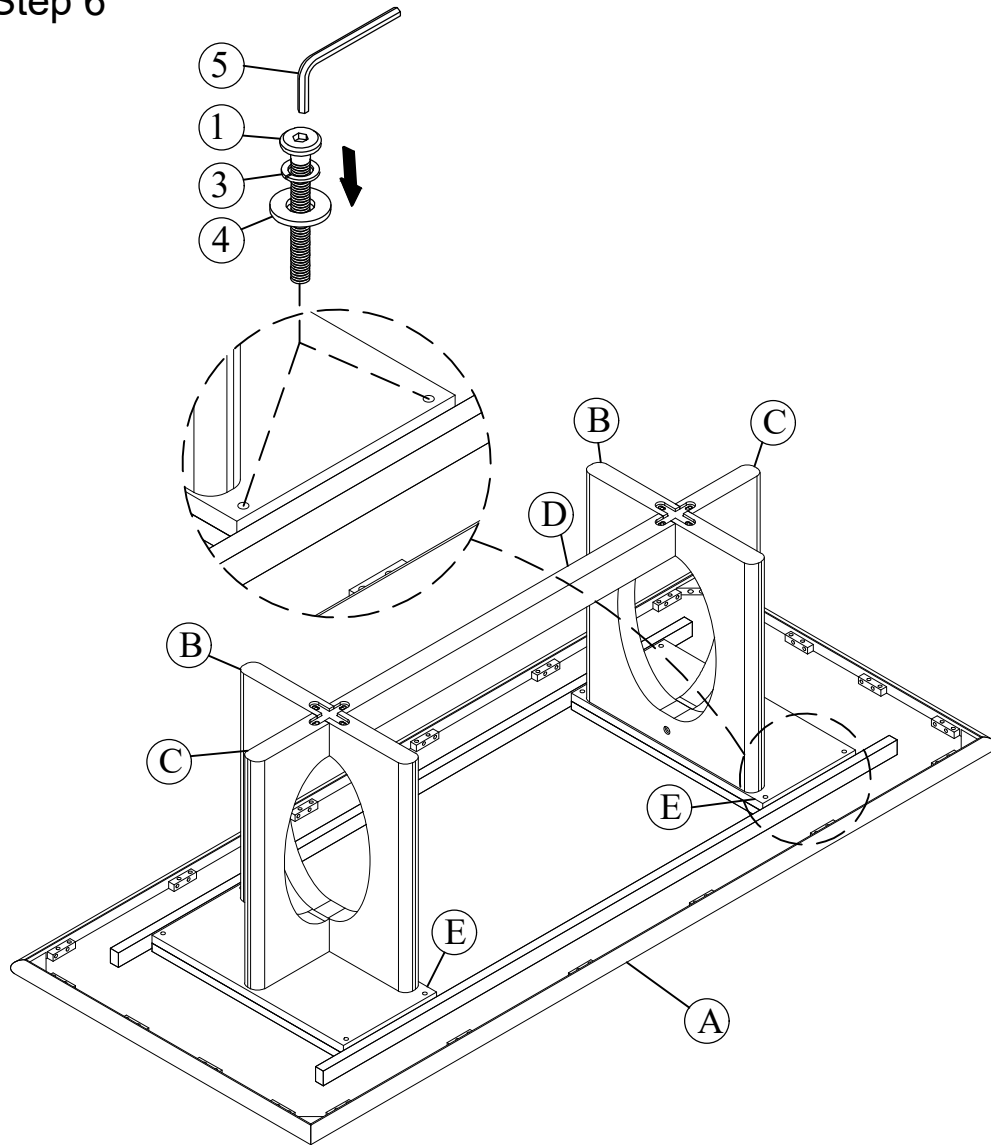

Step 7

