

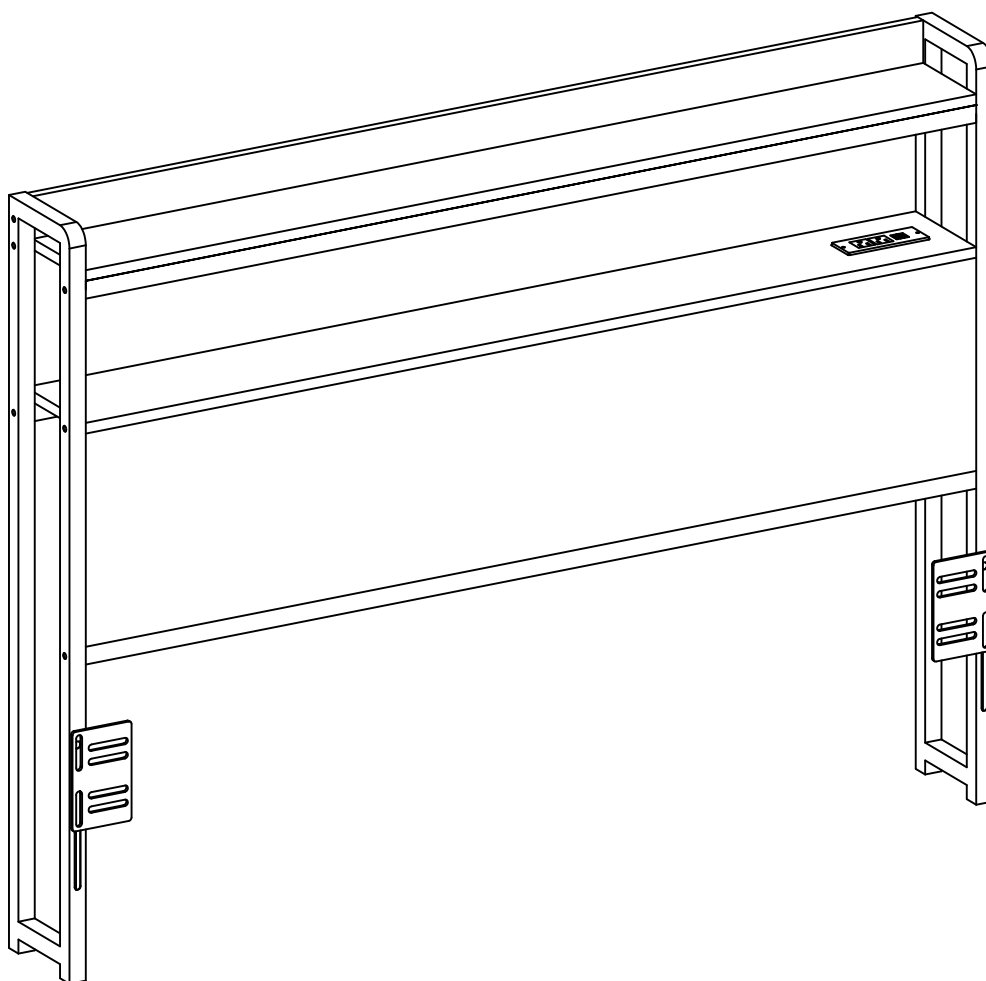

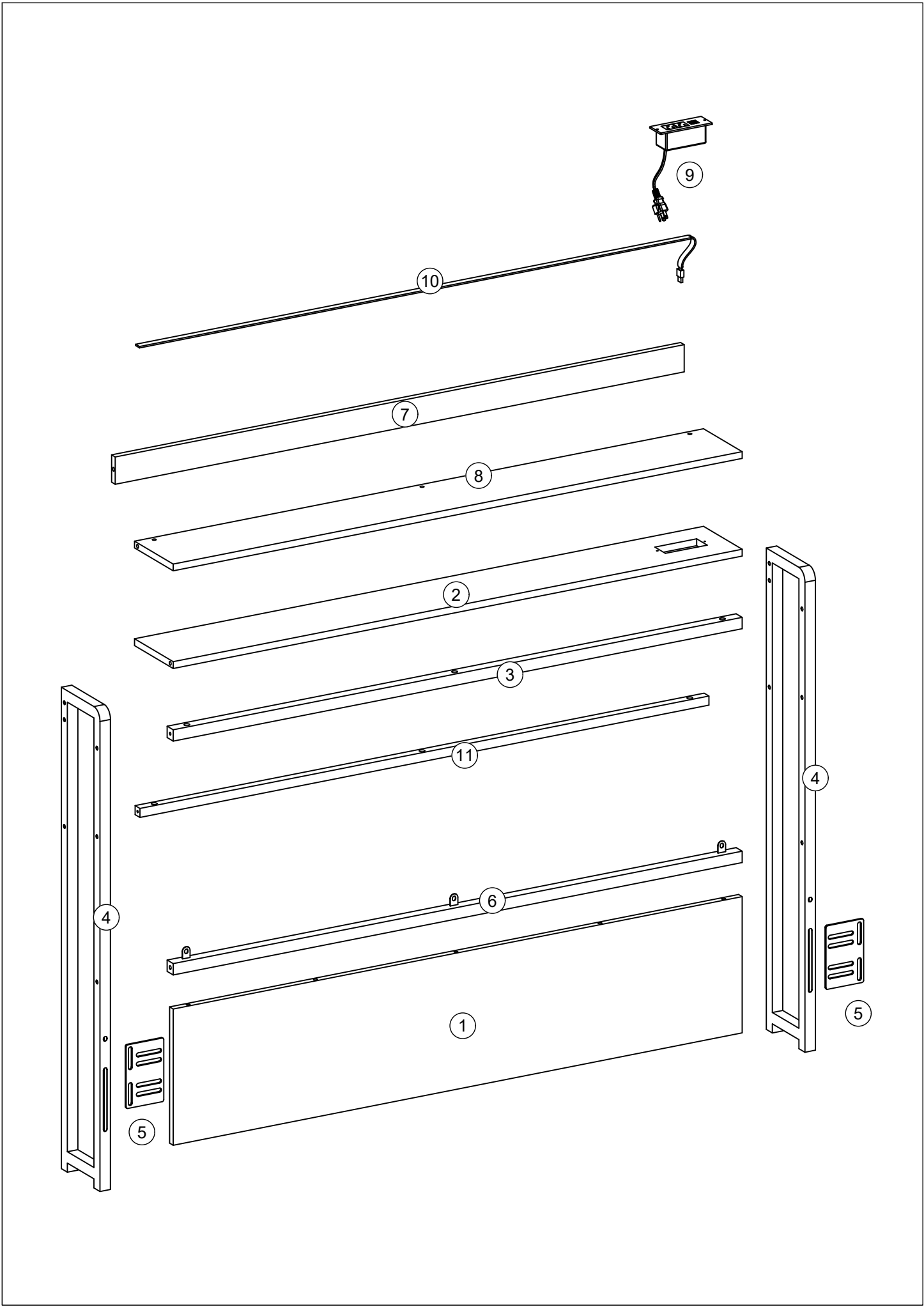





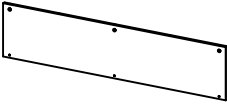

ASSEMBLY INSTRUCTION

CTB-01



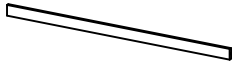

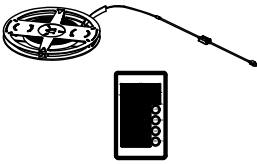
Parts List

<p>1</p>  <p>1pc</p>	<p>2</p>  <p>1pc</p>	<p>3</p>  <p>1pc</p>	<p>4</p>  <p>2pcs</p>
<p>5</p>  <p>2pcs</p>	<p>6</p>  <p>1pc</p>	<p>7</p>  <p>1pc</p>	<p>8</p>  <p>1pc</p>
<p>9</p>  <p>1pc</p>	<p>10</p>  <p>1pc</p>	<p>11</p>  <p>1pc</p>	

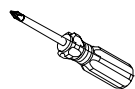



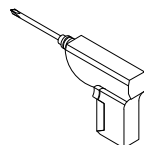





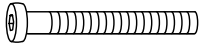
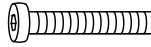

philips head screw driver
required of assembly
(Not include)





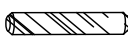
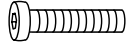

electric drill
(Not include)

Hardware List

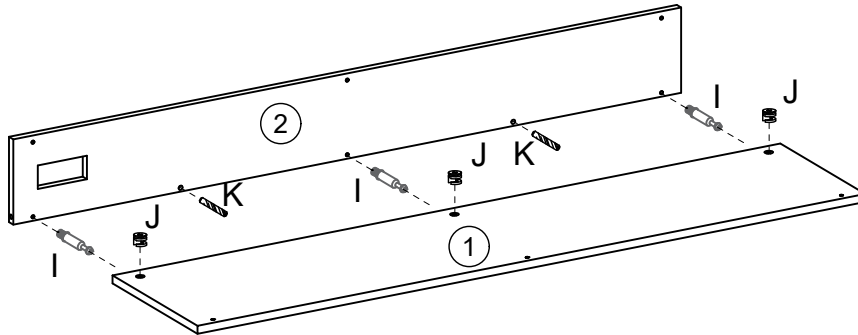
<p>A</p>  <p>M6*45mm 6pcs</p>	<p>B</p>  <p>M6*35mm 7pcs</p>	<p>C</p>  <p>M6*12mm 3pcs</p>
<p>D</p>  <p>8pcs</p>	<p>E</p>  <p>M6 4pcs</p>	<p>F</p>  <p>M6 1pc</p>
<p>G</p>  <p>M7*48mm 9pcs</p>	<p>H</p>  <p>M3.5*14mm 2pcs</p>	<p>I</p>  <p>3pcs</p>
<p>J</p>  <p>3pcs</p>	<p>K</p>  <p>Ø8*30 2pcs</p>	<p>L</p>  <p>M6*30mm 3pcs</p>
<p>M</p>  <p>M6 1pc</p>		

STEP 1:



I

3PCS
J

3PCS
K

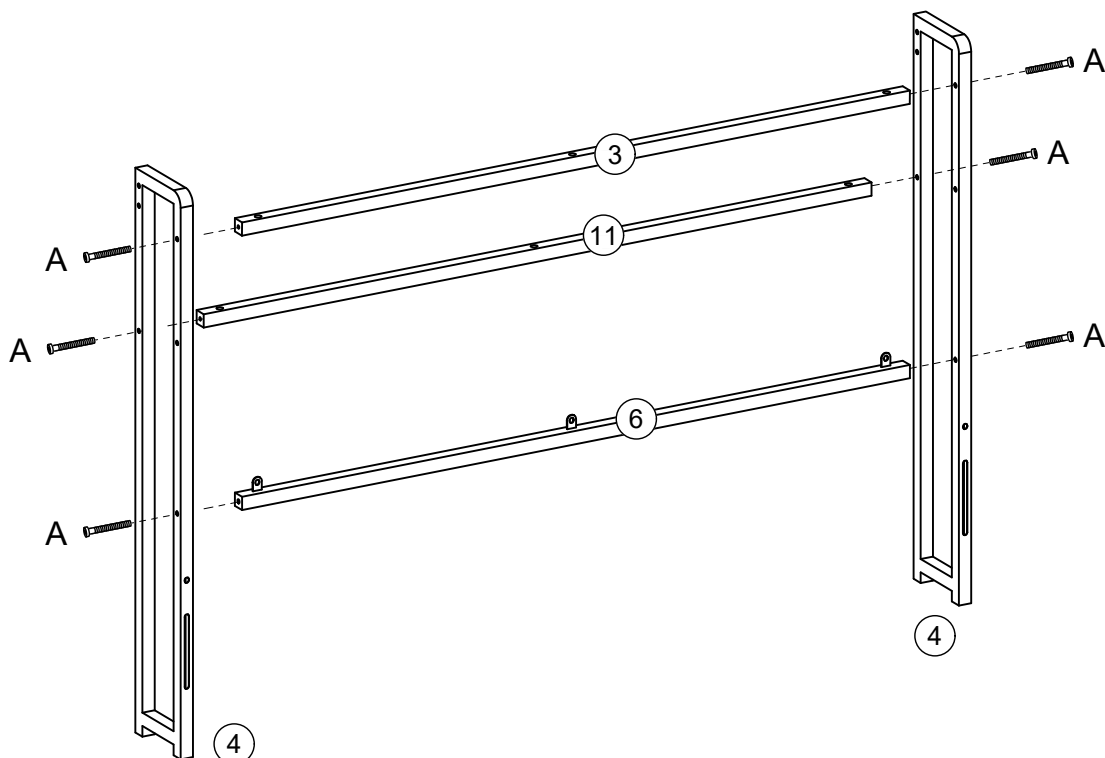
Ø8*30mm
2PCS

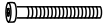

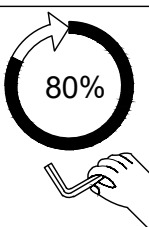
STEP 2:



A

M6*45mm
6PCS

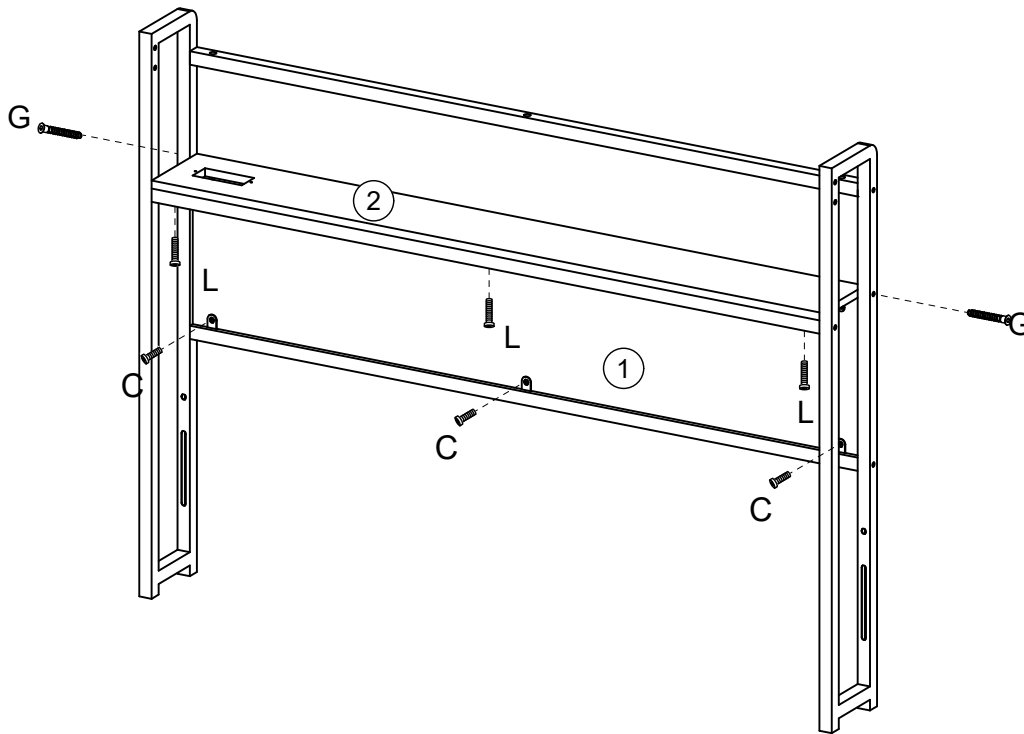

STEP 3:



C



M6*12mm
3PCS

G

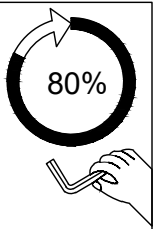

M7*48mm
2PCS

L



m6*30mm
3PCS

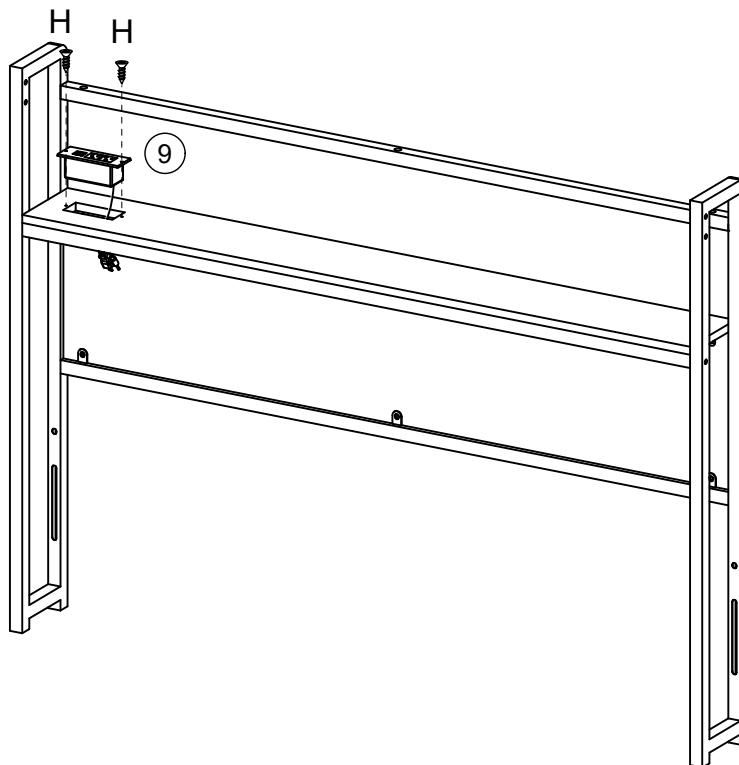

STEP 4:



H

M3.5*14
2PCS

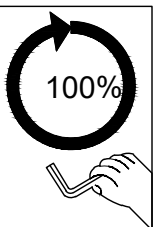

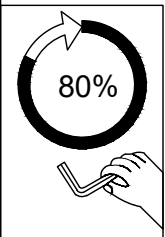
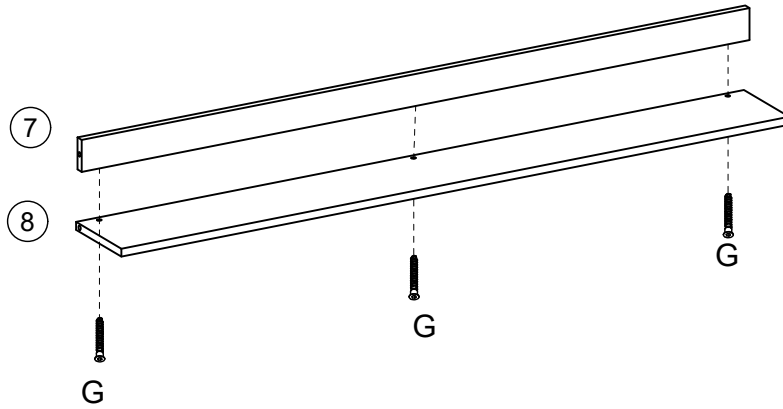

STEP 5:

G

M7*48mm
3PCS





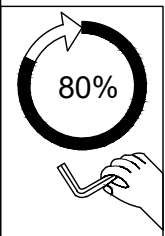
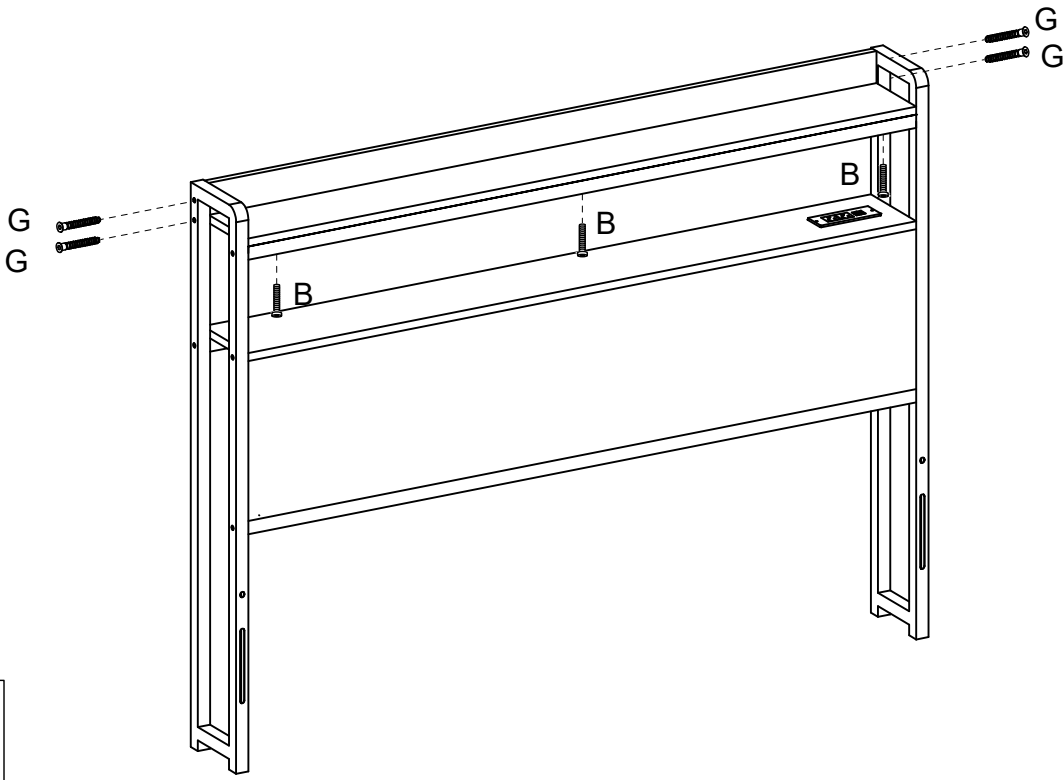

STEP 6:

G

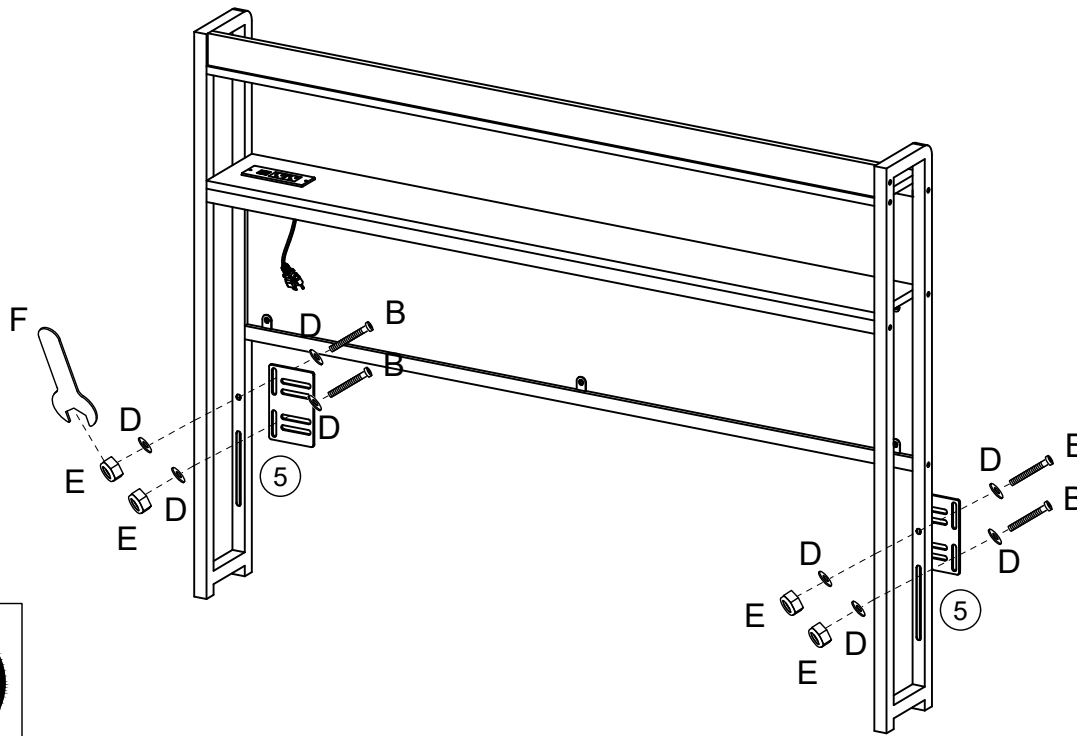
M7*48mm
4PCS
B

m6*35mm
3PCS



STEP 7:



B

M6*35mm
4PCS
D

8PCS
E

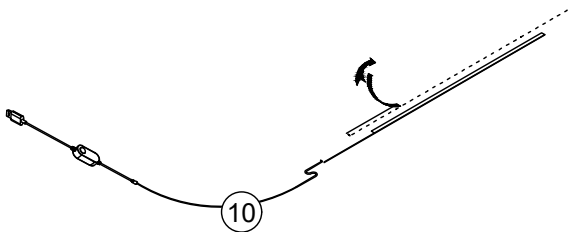
M6
4PCS
F

M6
1PC



STEP 8



Tear off the protective film of LED strips, then stick them underneath the side rails.

