

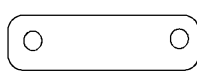





ASSEMBLY INSTRUCTION

CVFNR4569

PARTS

S.NO.	DESCRIPTION	QTY
F	 TOP	1 PC
G	 METAL CLIPS	4 PCS
H	 LEGS H1,H2,H3,H4	4 PCS

HARDWARE

S.NO.	DESCRIPTION	QTY
A	 ALLEN SCREW 20MM	4 PCS
B	 ALLEN SCREW 40MM	4 PCS
C	 WASHER	8 PCS
D	 SPRING WASHER	8 PCS
E	 ALLEN KEY 4 MM & 6 MM	2 PC

STEP 1

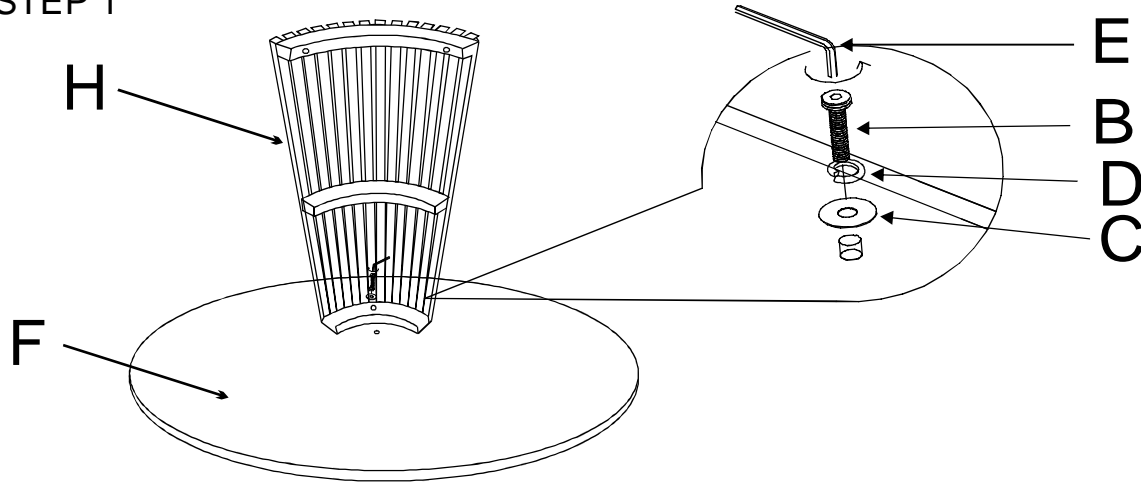

Note : Place Top on plain surface and Align the Hole with Legs.
Don't tighten any bolt until step 2 complete.

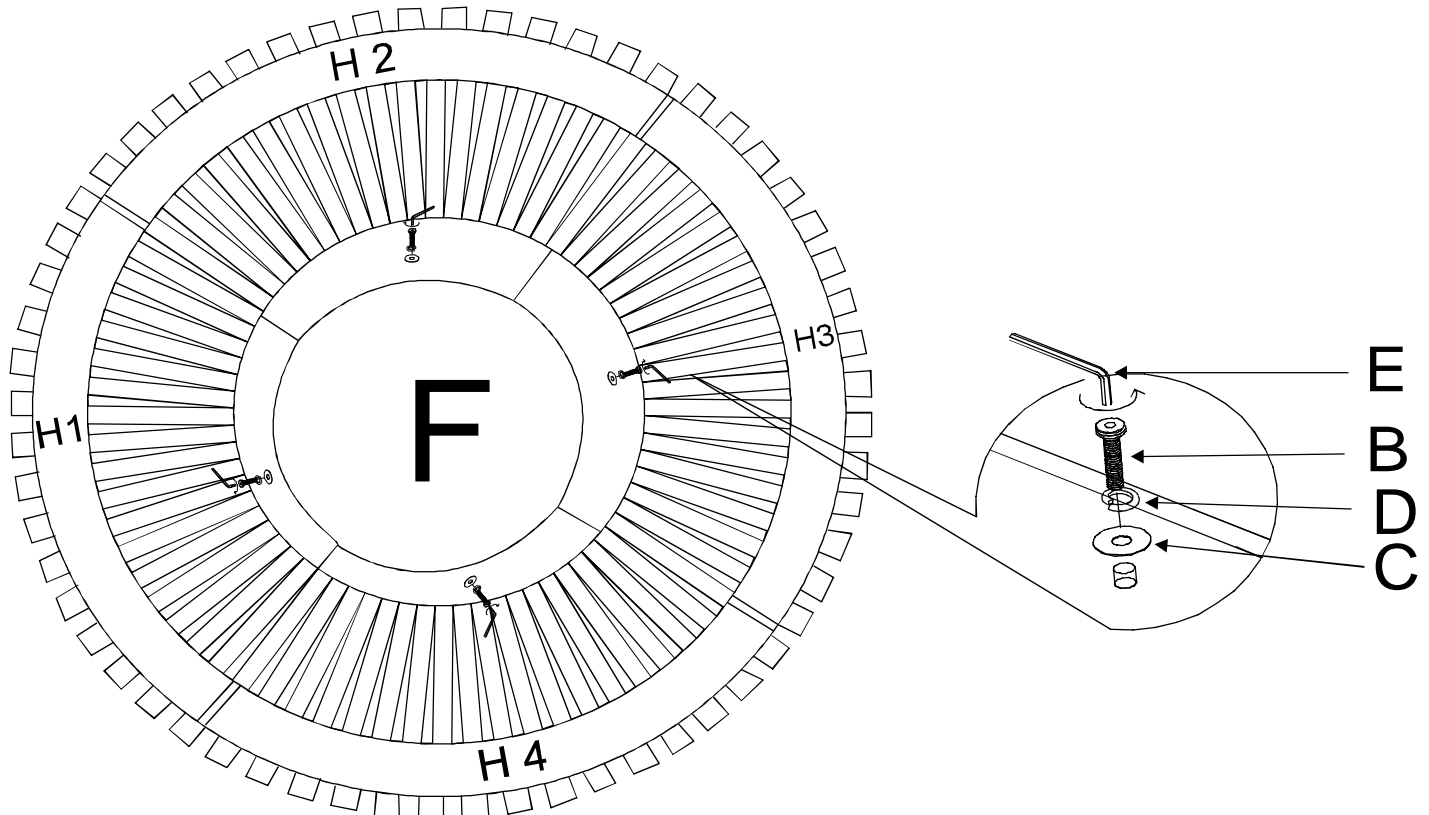

STEP 2

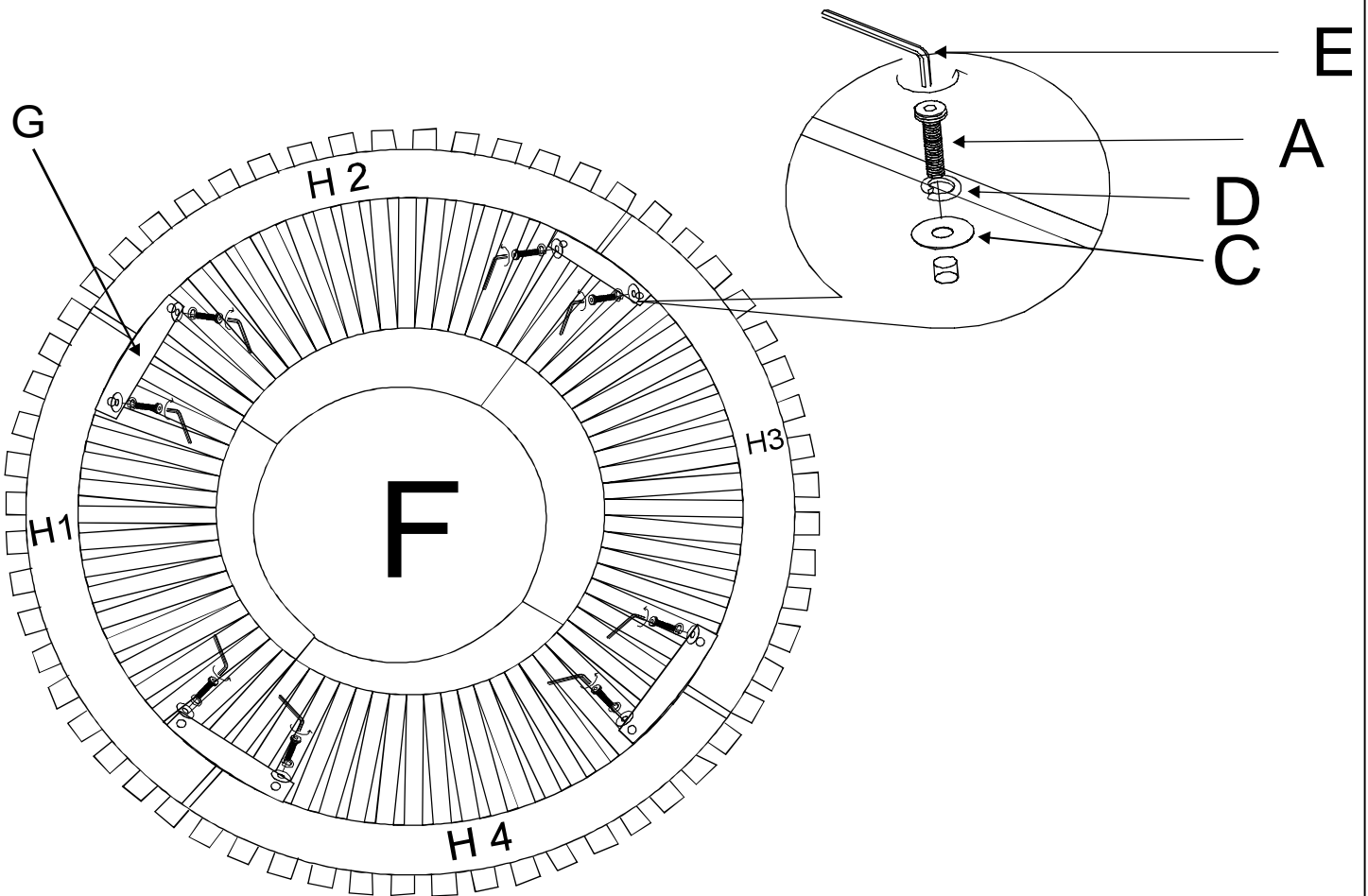

Note : please adjust the panels to alignment when installing the metal clips. Once all metal clips fixed and tighten, tighten all the bolts that on the back of top.

COMPLETE

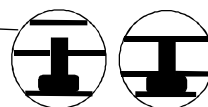
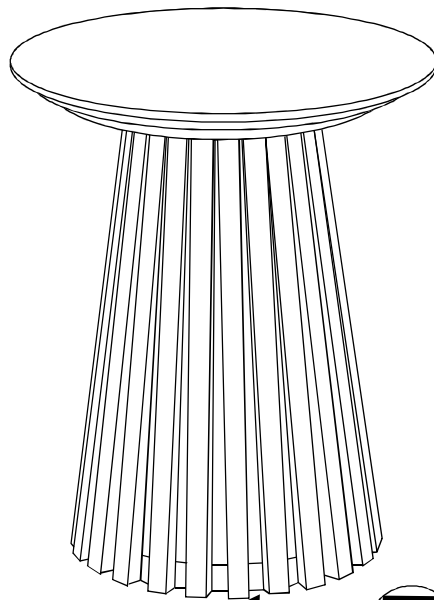

Adjust height
for balance