

SEATER ASSEMBLY INSTRUCTION

Thank you for purchasing this quality product. Be sure to check all packing material carefully for small parts which may have come loose inside the carton during shipment. Separate, identify and count all parts and hardware. Compare with the parts list to be sure all parts are present.

IMPORTANT : PLEASE READ INSTRUCTION BEFORE STARTING THE ASSEMBLY.

"DO NOT TIGHTEN SCREWS UNTIL COMPLETELY ASSEMBLED"

"DO NOT OVERTIGHT ANY HARDWARE"

WARNING : SMALL PARTS AND HARDWARE NOT FOR CHILDREN UNDER 3 YEARS. ADULT ASSEMBLY REQUIRED.

TABLE OF CONTENTS

HARDWARES LIST	PAGE 2
PARTS LIST	PAGE 3
PARTS' LOCATION	PAGE 4
ASSEMBLY STEPS	PAGE 5
ASSEMBLY COMPLETED	PAGE 5

ASSEMBLY TOOLS REQUIRED

1. Screwdriver (not provide)

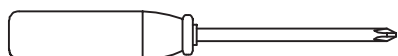

2. Hammer (not provide)

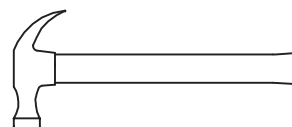

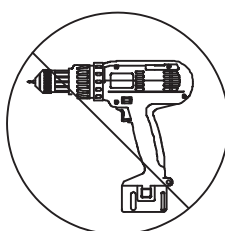

Skip the power drill this time.



SEATER ASSEMBLY INSTRUCTION

HARDWARE LIST

ITEM	DESCRIPTION	DRAWING	QTY
A	JCBC SCREW M6 x 15MM		12 PCS
B	M4 ALLEN KEY (65MM)		1 PC

SEATER ASSEMBLY INSTRUCTION

PARTS LIST

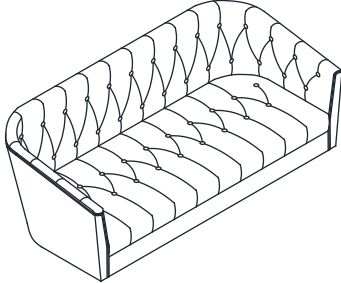
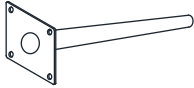
ITEM	DESCRIPTION	DRAWING	QTY
1	LOVE SEAT		1 PC
2	LEG		4 PCS

SEATER ASSEMBLY INSTRUCTION

PARTS ' LOCATION

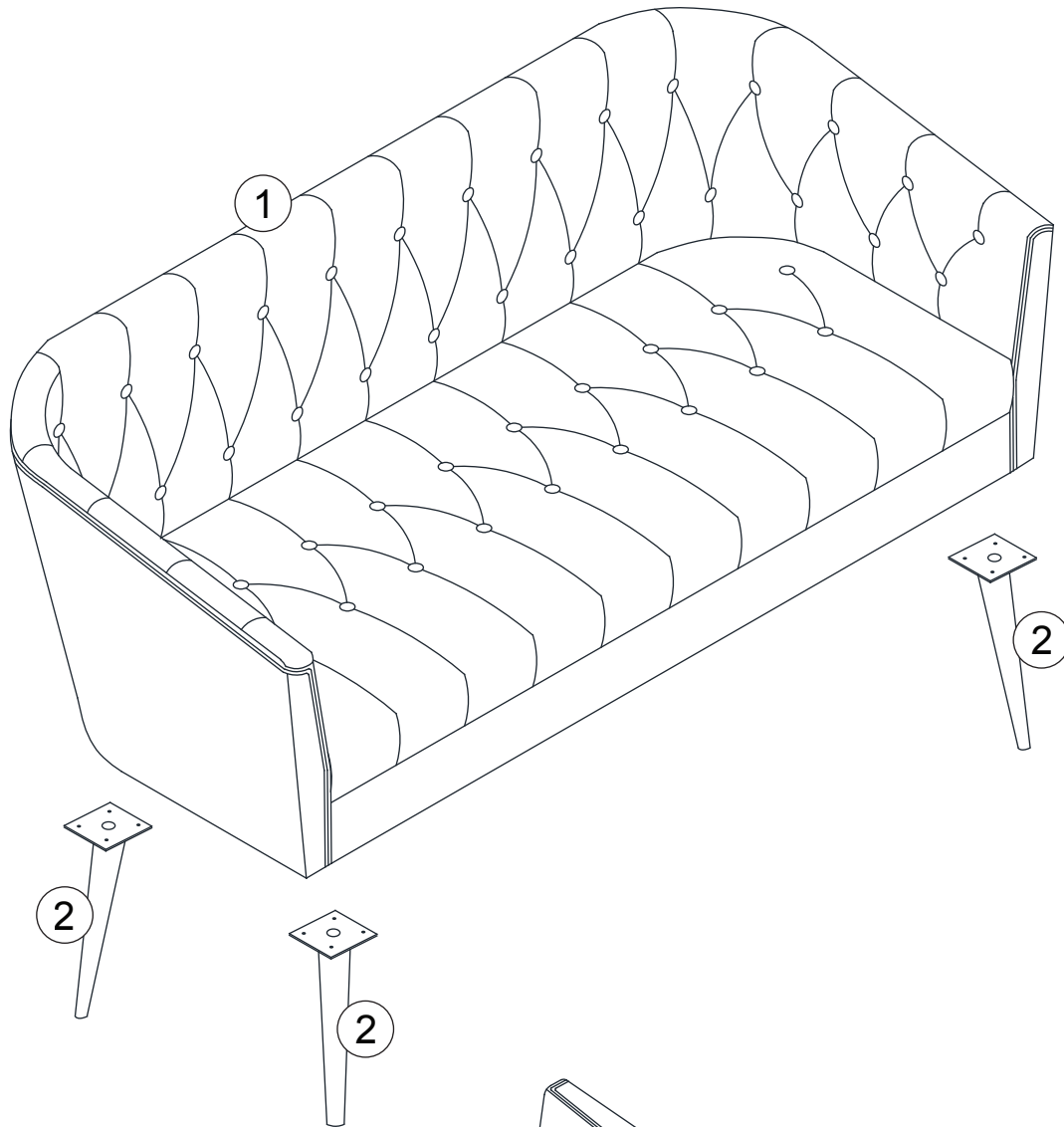

Open zipper to take out the leg

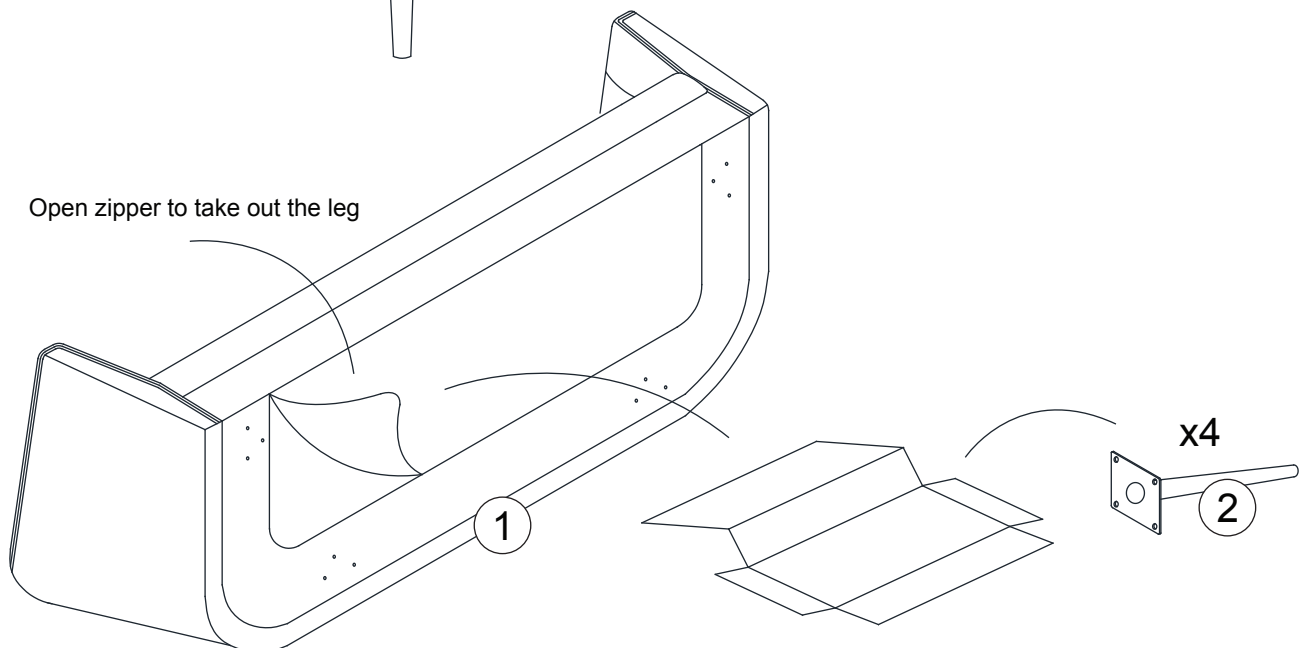

SEATER ASSEMBLY INSTRUCTION

STEP 1

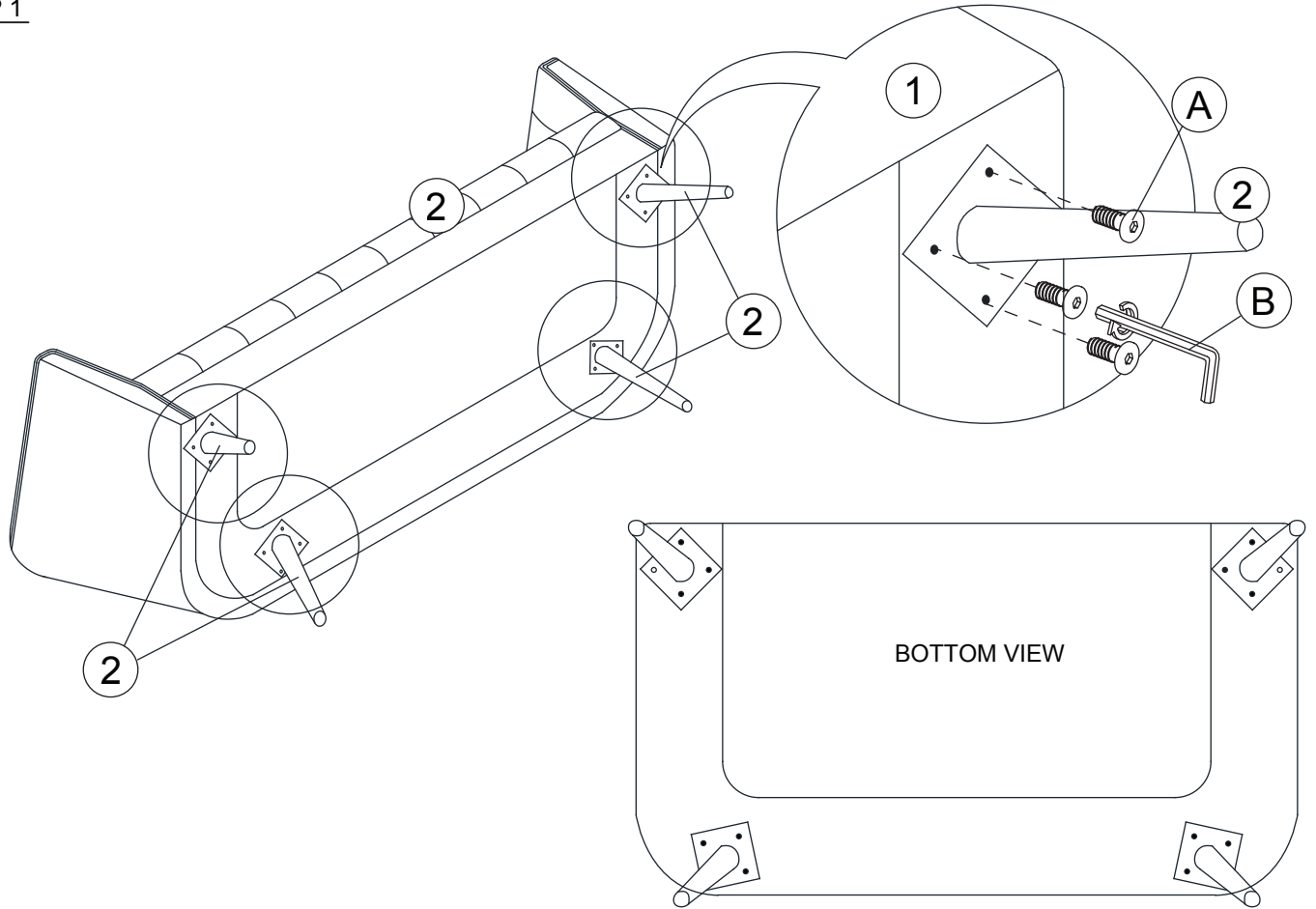

STEP 2

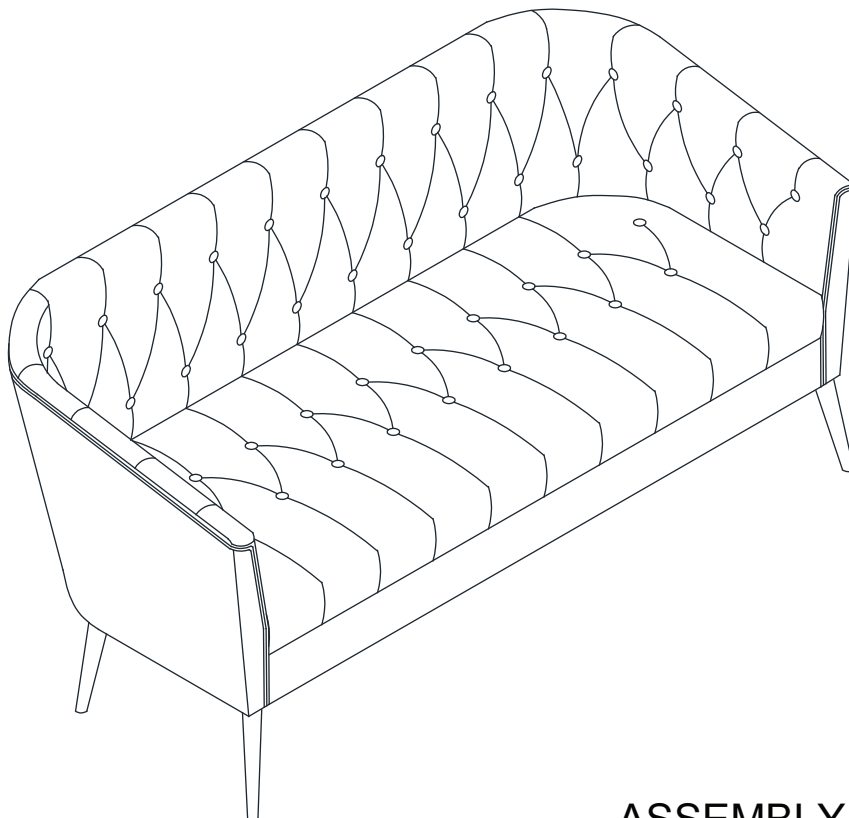

ASSEMBLY COMPLETED