

# **DECO WALL SKYLINE**

**INSTRUCTION MANUAL**

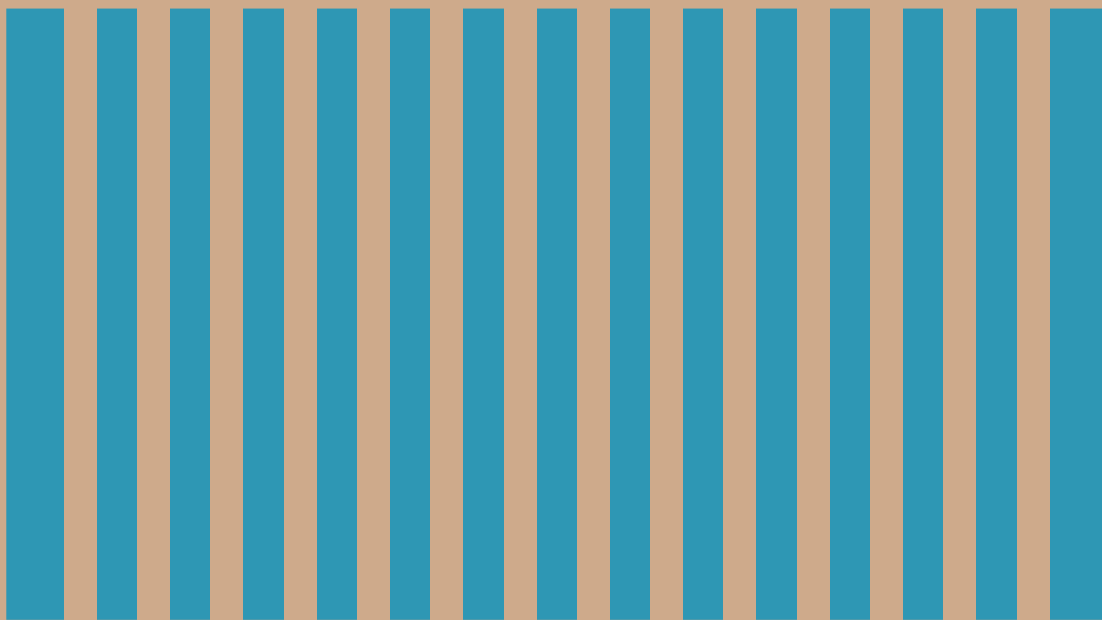

# THANK YOU FOR PURCHASING THE MIRADOR DECO WALL SKYLINE!



This manual will provide you with clear and detailed instructions on how to safely and correctly assemble and maintain your Deco Wall Skyline, to ensure it brings you many years of use and enjoyment.

## **IMPORTANT**

Please read the entire manual carefully before assembling and using your Deco Wall Skyline, and please ensure the manual is kept in a safe place for future reference.

Any use or modification to the Deco Wall Skyline not included in this manual shall be considered as improper use, which may cause considerable danger to users and property and will void the product warranty.

Please only use this product for its intended purpose within a residential environment. Failure to do so will void your warranty.

We reserve the right to make changes for product improvements.

For parts and customer service, please call +1 (877)-506-4777 in the U.S. and Canada (English and Spanish) Monday - Friday: 6:30 am - 4:30 pm, Saturday – Sunday: 8:30 am – 4:30 pm, Pacific Time. Or email: [support@miradoroutdoor.com](mailto:support@miradoroutdoor.com)

Digital instruction manual is also available on our official website [www.miradoroutdoor.com](http://www.miradoroutdoor.com) for your reference.

# TABLE OF CONTENTS

- Before Assembling Your Deco Wall Skyline	3
- Important Safety Advice	5
- List of Parts	7
- Assembly	8
- Enjoy Your Deco Wall Skyline	12
- Care & Maintenance	13
- Warranty & Complaints Procedure	14

# BEFORE ASSEMBLING YOUR DECO WALL SKYLINE

**Please read all the instructions carefully before you begin, and follow the steps in the order they are presented.**

## **Make sure you have all the tools required for assembling your Deco Wall Skyline**

In order to assemble your Deco Wall Skyline safely and correctly, please ensure you have access to the following tools and accessories, all of which are not provided.



2 Hard hat



2 Protective gloves



Safety knife

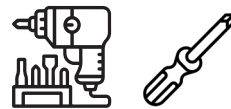

Screwdriver



Hammer drill

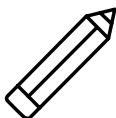

Pencil



2 Step ladders



Hammer

## **Check to ensure there are no missing parts:**





Before you begin assembly, please check that you have all the parts required to assemble your Deco Wall Skyline. Please also carefully check that the quantity of parts match with that of the model you have purchased.

If any parts are missing, please refer **Warranty & Complaints Procedure** to contact customer service before beginning the assembly.

## **Prepare the parts you will need for each step:**

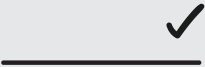
In the **Assembly** section of the manual, each step indicates the necessary parts and quantities required to complete the step. We recommend that you prepare the parts you will need for each assembly step. Doing this will save you time and effort during assembly. If possible, place the parts on cardboard or other soft surface to protect from scratching the painted surfaces.

### Select a suitable location:

The ground should be solid and flat	The ground should be level	The must be positioned and fixed on a properly installed Mirador pergola, which is installed on a flat concrete ground, providing proper stability.
		
		

### Warning:

Most terraces or patios are designed with a slight slope to prevent (rain) water from forming pools or reaching the house or other structures. For the perfect Deco Wall Skyline assembly, a level concrete surface without such a slope is required. Small pebbles could also prevent the Deco Wall Skyline from being safely secured on the ground.

If the Deco Wall Skyline is installed on an uneven surface, it may prevent accessory components from working correctly and may void the product warranty.

### Prepare a foundation:

To prepare it, you need to:

- check for underground pipes and cables (Call 811 before you dig if you live in the USA)
- check with your local authorities regarding any building permits that may be required
- contact a reliable contractor to install a concrete base if you don't have one

Do not assemble the Deco Wall Skyline on sandy, muddy or loose soil, as the stakes do not have the sufficient anchorage to be installed in these types of soil.

# IMPORTANT SAFETY ADVICE

For the safety of all persons assembling and using the Deco Wall Skyline, it is important to follow the safety guidelines below.

It is recommended that two people lift the deco wall once assembled. Ensure you lift with the correct posture & technique.

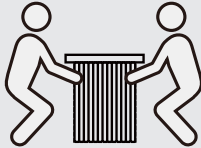

Always wear appropriate work shoes, gloves and eye protection when working.

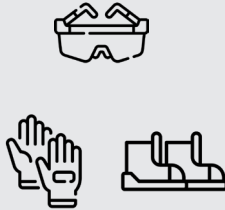

Work well away from power lines, particularly when handling metal parts.

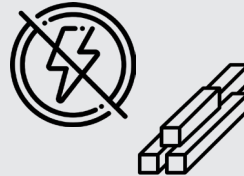

If using power tools or a ladder, always follow the manufacturer's safety instructions.



Make sure the deco wall complies with local building regulatory codes.



Working at heights can be dangerous. Always wear protective clothing to prevent injury in the event of a fall.







Only use ladders and scaffolding with a sufficiently high load bearing capacity.





Do not assemble the deco wall when you find damaged parts or any parts missing. Only use replacement parts that are approved by the manufacturer.







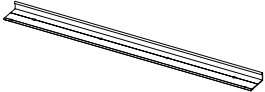
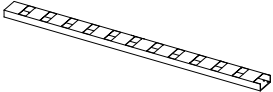

<p>Please recycle packaging where possible.</p>	<p>After prolonged use we recommend you check all the fittings are tightened securely.</p>	<p>Install on non-Mirador branded pergola will void the product warranty and can damage the operation mechanism.</p>	<p>Changes to the design or configuration of equipment may not be made without consulting the manufacturer or authorized representative.</p>
			

<p>Do not attempt to assemble the product if you are tired, or after consuming alcohol.</p>	<p>Hot items such as recently used grills, fire pits etc. must not be stored close to the deco wall.</p>	<p>Keep children and pets away from the assembly area until the work is completed.</p>	<p>Do not attempt to assemble the deco wall in windy or wet conditions.</p>
			

<p>Do not touch moving parts during operation.</p>	<p>Dispose of all plastic bags safely. Keep them out of the reach of children.</p>
	

# LIST OF PARTS

REF	PART NAME	QTY		
		3m/10ft.	3.6m/12ft.	4m/13ft.
<b>A</b>	 Horizontal top bar	1	1	1
<b>B</b>	 Horizontal beam	2	2	2
<b>C</b>	 Vertical bar	12	15	16
<b>D</b>	 Foot pad	2	2	2
<b>E</b>	 Screw ST5.5x50mm	4	4	4
<b>F</b>	 Plastic expansion pipe 8x40mm	4	4	4
<b>G</b>	 Screw ST4.8x25mm	2	2	2
<b>H</b>	 Screw ST4.2x25mm	40+2	46+2	48+2

# ASSEMBLY

## 1. Horizontal beam assembly



Assembly Video

### 1A

Insert all of the vertical bars **C** into horizontal beams **B**.

**B** x 2



Part \ Length	3m/10ft.	3.6m/12ft.	4m/13ft.
---------------	----------	------------	----------

<b>C</b>		12	15	16
----------	--	----	----	----

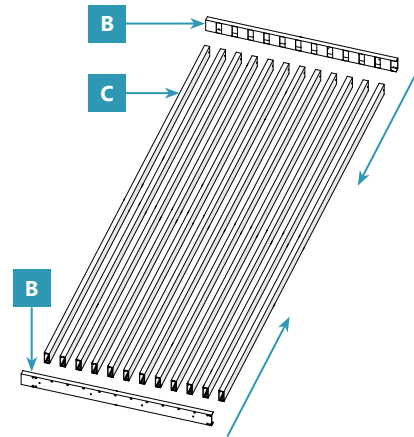

### 1B



Secure the horizontal beams **B** to the vertical bars **C** by tightening the screw **H** clockwise.

Part \ Length	3m/10ft.	3.6m/12ft.	4m/13ft.
---------------	----------	------------	----------

<b>H</b>		28	34	36
----------	--	----	----	----

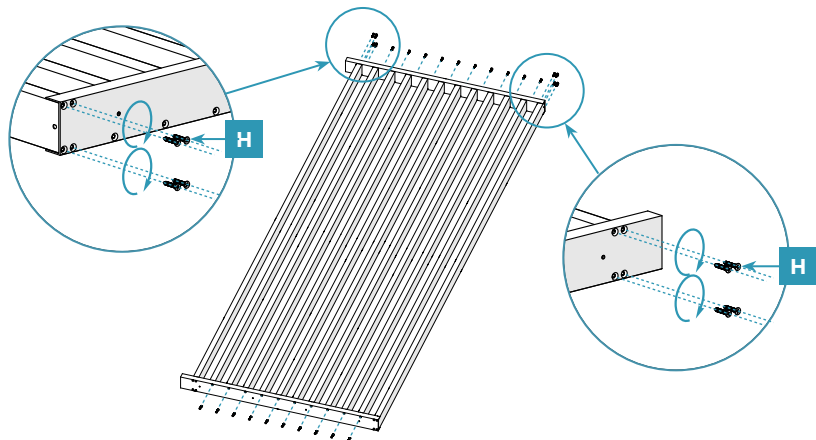

## 2. Horizontal top bar & foot pad assembly



2A

Secure the horizontal top bar **A** to the horizontal beam **B** by tightening the screw **H** clockwise.

**Notice:**

Pay attention to the direction of the horizontal top bar **A** while assembled to the horizontal beam **B**.

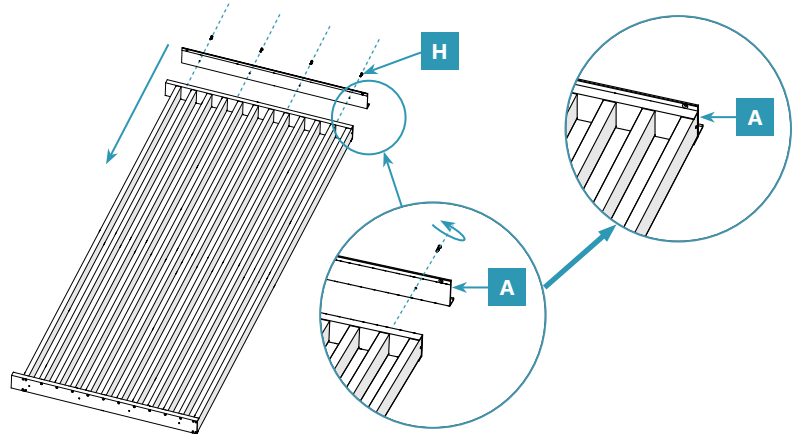

**A** x 1



**H** x 4



2B

Assemble the foot pads **D** to the bottom of the deco wall with screw **H** clockwise.

**Notice:**

There is no need to assemble foot pad **D** on the side near the right pergola pillar.

Below parts are needed for 3 different assembly positions of the deco wall.

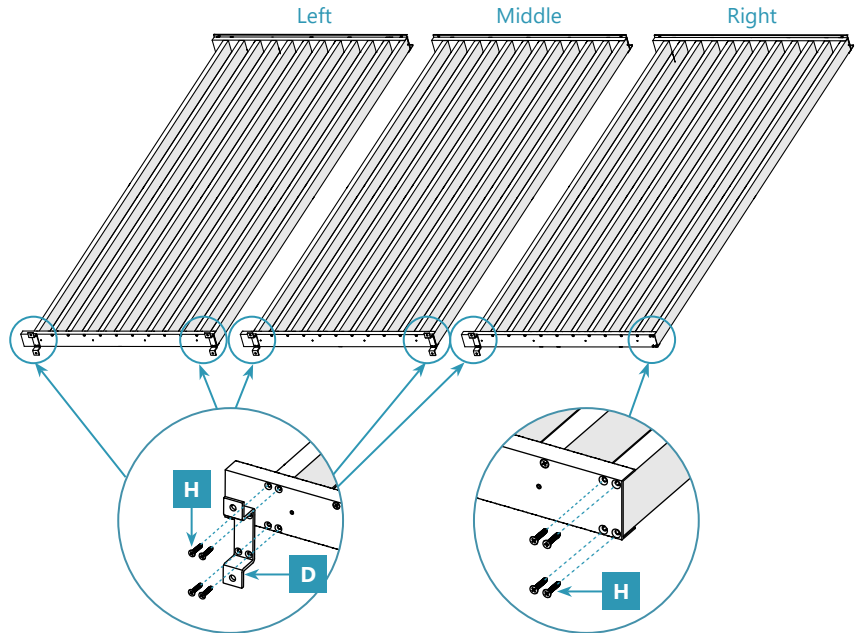

**H** x 8



Part \ Length	Left/Middle wall	Right wall
<b>D</b> 	2	1

# 3. Install the Deco Wall Skyline onto a Mirador® pergola



## 3A

Position the deco wall (against the pergola pillar or in the middle), mark the position of the drill holes on the ground with pencil. Remove the wall, drill holes with hammer drill and knock in the plastic expansion pipe **F** with hammer.

### Notice:

Always start from the left/right wall if it is intended to install more than 1 deco wall on one side of the pergola.

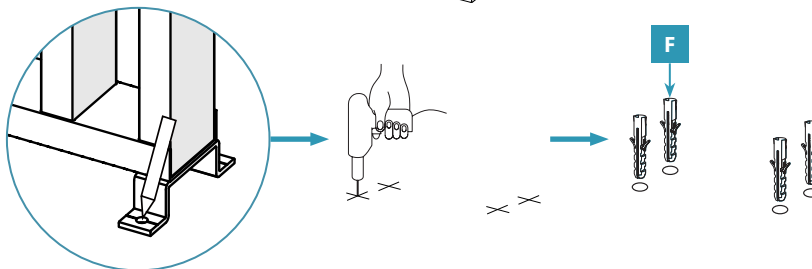
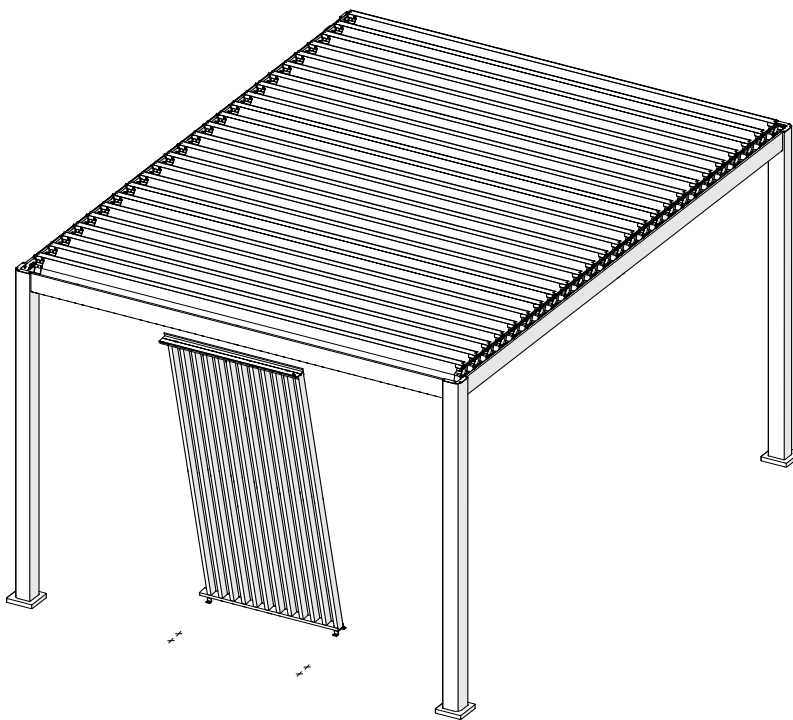

Part \ Length	Left/Middle wall	Right wall
<b>F</b>	4	2



or

# 3B

Hook the deco wall onto the beam of the pergola, secure the wall with screw

**G**

**G** x 2





or

# 3C

Fix the deco wall to the ground with screw

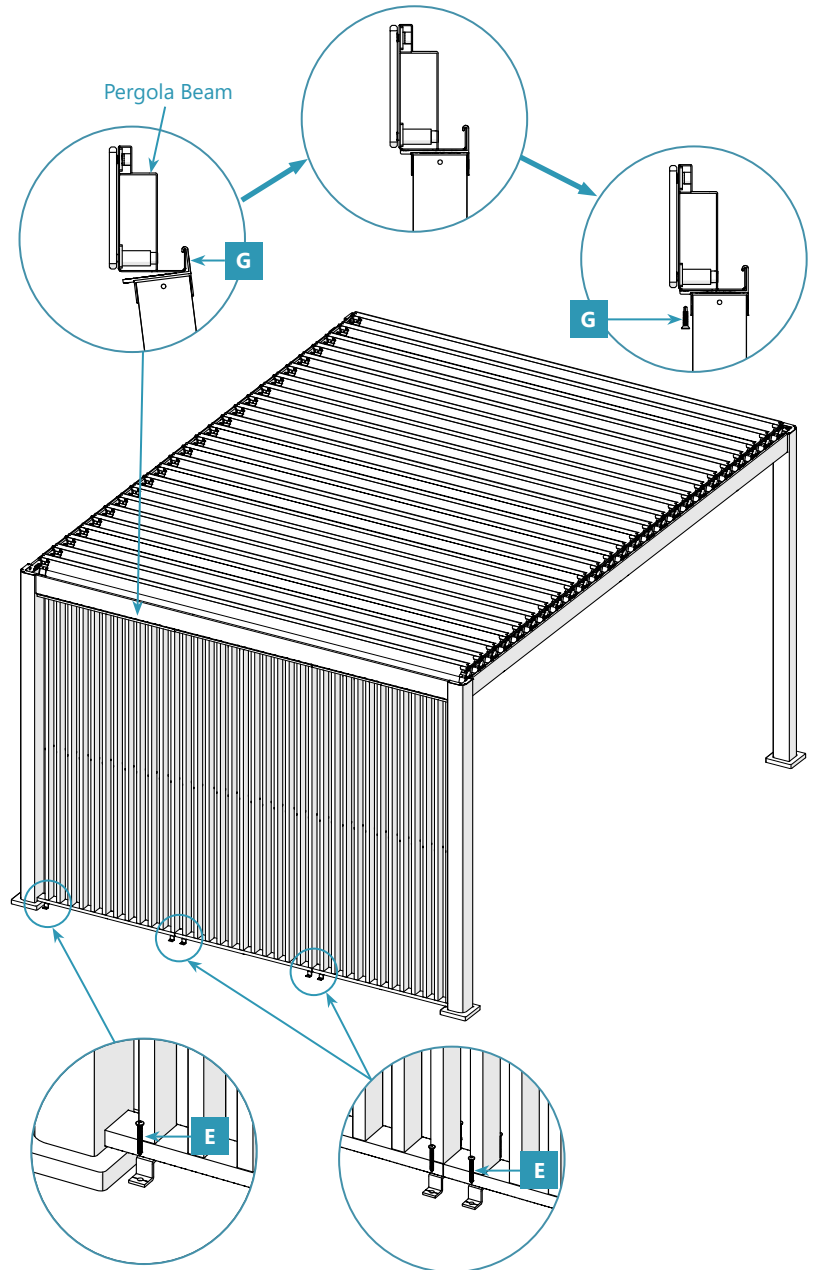
**E**







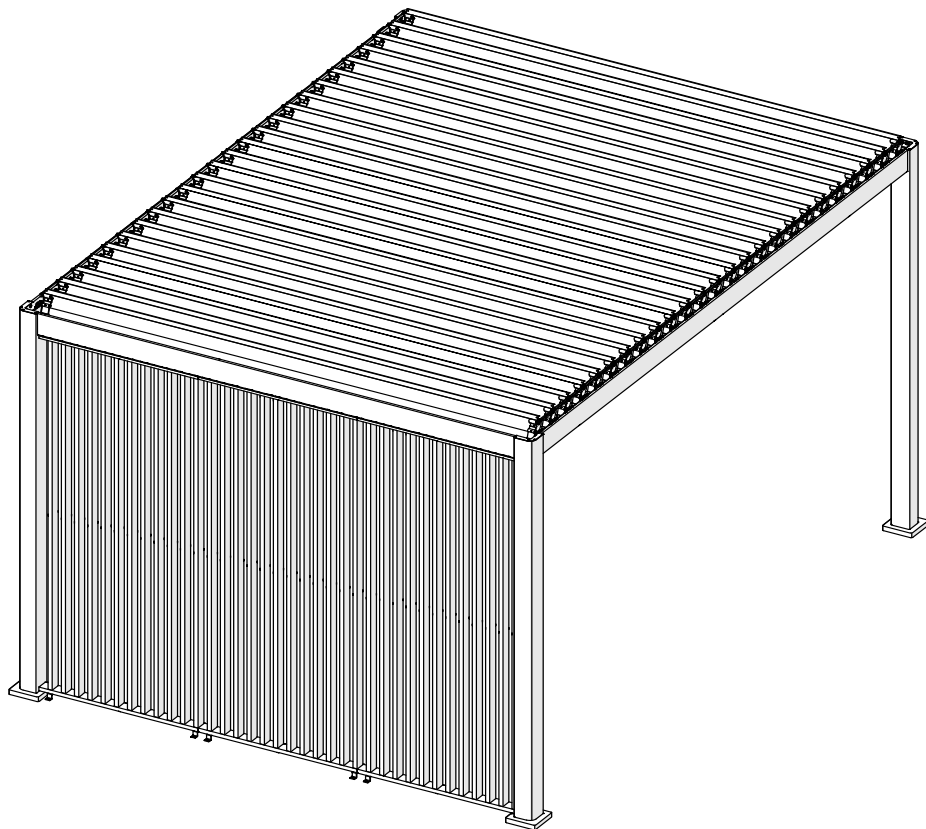

Part \ Length	Left/Middle wall	Right wall
<b>E</b> 	4	2

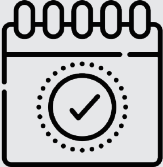
# ENJOY YOUR DECO WALL SKYLINE



# CARE & MAINTENANCE

<p>Dust and dirt will collect on the deco wall and will require periodic cleaning.</p>	<p>Use a water/detergent mixture and a soft clean cloth to clean the deco wall.</p>	<p>Air dry or wipe with a soft clean cloth.</p>
		
<p>In coastal areas, it is recommended that you frequently spray the deco wall with water to reduce accumulation of salt and dirt.</p>	<p>From more soiled areas, rinse the surface with clean water from top to bottom.</p>	<p>Do not use any acidic, alkaline or petroleum based spray lubricants.</p>
		

\* Alcohol based cleaner: methyl alcohol, ethyl alcohol, butyl alcohol, Isopropyl alcohol, etc.

# WARRANTY & COMPLAINTS PROCEDURE

**For terms and conditions of our limited warranty, please visit [www.miradoroutdoor.com](http://www.miradoroutdoor.com) or contact your local Mirador sales representative.**

**Complaints procedure:**

- The complaint must include an order number or transaction number. Goods without an order number or transaction number are not covered under the warranty.
- The complaint must include a detailed description of the defect, the name of the company which assembled the product if 3rd party was used and the date when the defect was discovered.
- At Sorara Outdoor Living USA Inc's discretion, customer must offer supplier the photos/videos of the issue/damaged parts. Otherwise, supplier reserves the right to refuse replacement parts or credit.
- Please save a copy of your purchase receipt.

**Contact:**

**Customer Service:** [support@miradoroutdoor.com](mailto:support@miradoroutdoor.com)

**Need Assistance? Call** +1 (877)-506-4777

**Hours of Operation:**

**Phone Support:** Monday - Friday: 6:30 am - 4:30 pm, Saturday – Sunday: 8:30 am – 4:30 pm, PST.



**Email Support:** We are available 24 hours a day. Please allow up to 24 hours for a response.

**Chat With Us Online:** [miradoroutdoor.com](http://miradoroutdoor.com), Monday - Friday: 5:30 am - 2:00 pm, Saturday – Sunday: 8:30 am – 4:30 pm, PST.

**Note:** Our team is available to assist you during these hours. If you have any inquiries or require support outside of these hours, please leave a voicemail, send an email, or use our online contact form. We will get back to you promptly during the next available support hours. Thank you for choosing Mirador Outdoor!

more to  
enjoy

FOLLOW US ON  
WWW.MIRADOROUTDOOR.COM

 @miradoroutdoor  @MiradorOutdoor  
 @miradoroutdoor  @miradoroutdoor



Printed on 100%  
post-consumer  
recycled paper

