





WOOD BACKLESS STOOL

Counter Stool/Grey Fabric/Vinyl
Barstool/Grey Fabric/Vinyl

Examine all packaging material for small parts that may have come loose during shipment. Periodic checks are recommended to insure that all components are in proper position, tight and free from damage. Keep this assembly instruction for future reference. Adult assembly is required.

HARDWARE LIST

- A (8) Ø5/16" x 2-1/4" Bolts
- B (8) Ø5/16" x 19 x 1.2mm Flat Washers
- C (8) Ø5/16" Spring Washers
- D (1) 100 x 30 x 5mm Allen Wrench
- E (8) #8 x 1-1/2" Screws

PART	QTY	HARDWARE	PART	QTY	HARDWARE
A	8		B	8	
C	8		D	1	
E	8				

PARTS LIST

- F (1) Cushion
- G (2) Long Crossbars
- H (2) Short Crossbars
- I (4) Legs

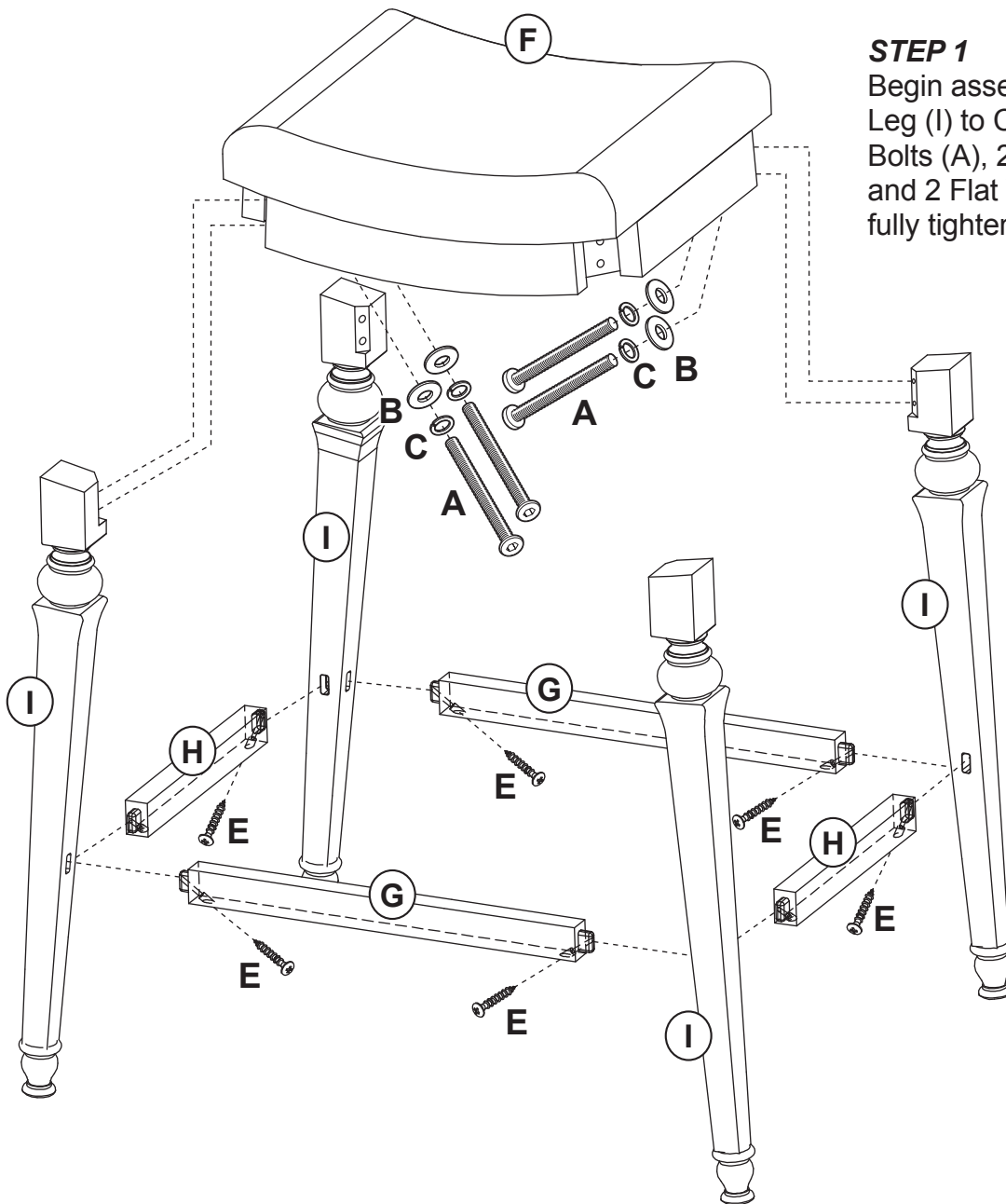

STEP 1

Begin assembly by attaching each Leg (I) to Cushion (F) using 2 Allen Bolts (A), 2 Spring Washers (C) and 2 Flat Washers (B). Do not fully tighten all bolts.

STEP 2

Next attach each Short Crossbar (H) in between a pair of Legs (I) using 2 Screws (E) per crossbar. Attach Long Crossbars (H) in between Legs (I) using 2 Screws (E) per crossbar. Tighten all screws with Phillips head screwdriver (not included). Tighten all bolts with Allen Wrench (D) provided. The assembly is now complete.

CARE & MAINTENANCE: The touch of a soft cloth is all the maintenance the finish will ever need. Please do not use harsh or abrasive cleaners for polishing, as they may cause damage to the finish. Periodic checks are recommended to make sure that all hardware is securely tightened.