

ASSEMBLY INSTRUCTION



This instruction booklet contains important safety information. please read and keep for future reference.

This sofa collection can works as modular sofa function, you can buy different section of the sofa such as armrest sets, armless middle seat, and ottoman to build it as 2 seater sofa, 3 seater sofa, 4 seater sofa, L shape sectional sofa, U shape sofa and sofa sets.

Measure your living room size before you make a decision to buy more components to ensure all sofa section are well fit your living room area.

To ensure safe and satisfactory use of this product, please carefully read the below instructions before hand.

- 1.This sofa ships in several boxes,we recommend unpacking and starting assembly when several boxes are received.
- 2.Our cushions are vacuum packed for convenient shipping. Please allow 2-3 days for them to fully expand to their original shape and for any wrinkles to disappear.
- 3.In the event that a part is damaged or missing,no need to return the product,we will gladly help and ship your replacement parts free of charge.



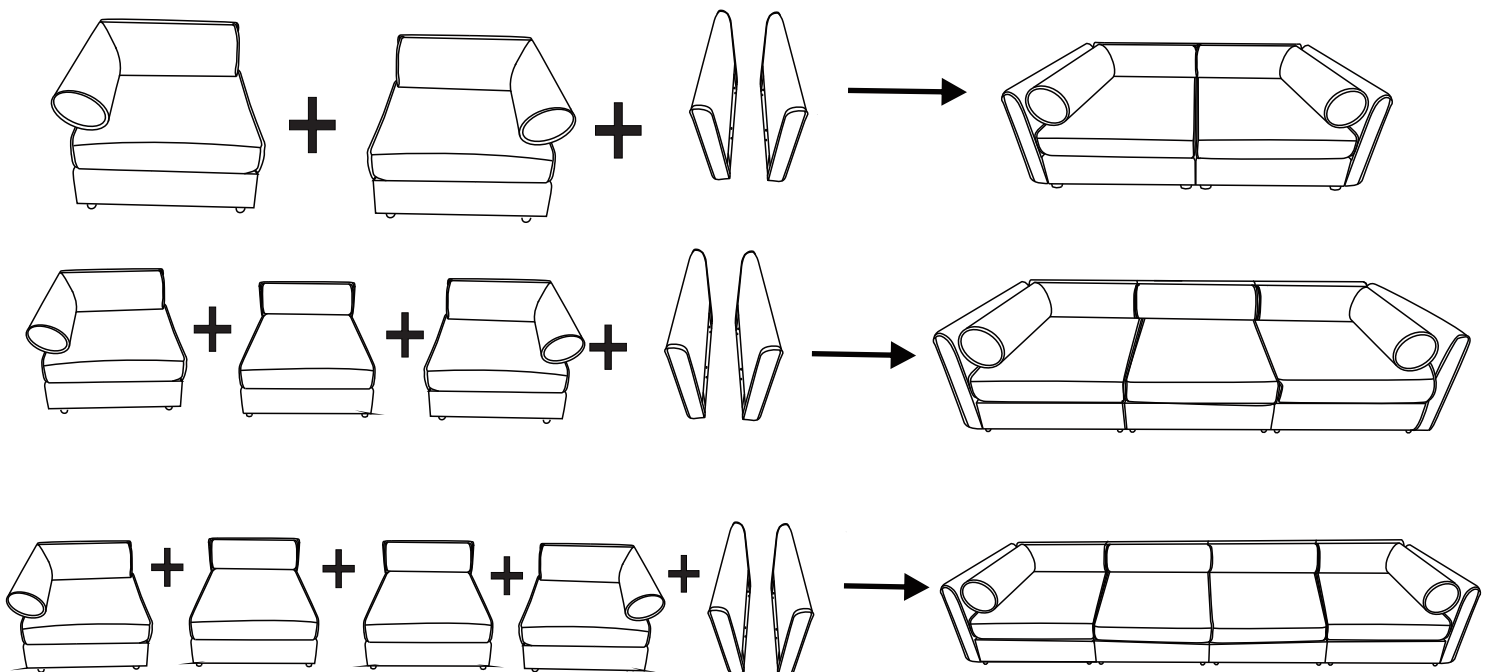

Below are some guidelines for you how you can do mix and match.

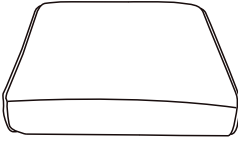
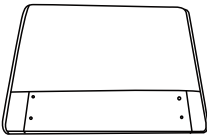
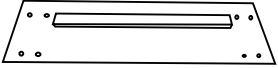
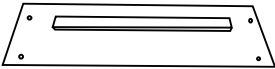
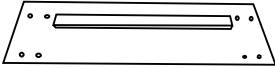
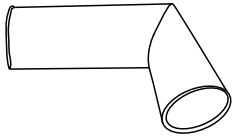
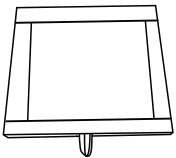
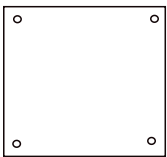
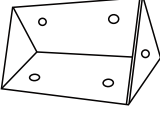
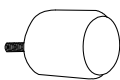
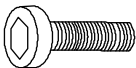
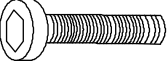

Assembly Instructions

IF YOU BUY 2 SEATER SOFA
 please follow below assembly instruction

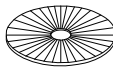
Parts List

<p>A</p>  <p>Backrest*2</p>	<p>B</p>  <p>Seat cushion*2</p>	<p>K</p>  <p>Armrest*2</p>	<p>C</p>  <p>Side panel*4</p>	
<p>D</p>  <p>Front panel*2</p>	<p>E</p>  <p>Back panel*2</p>	<p>Q</p>  <p>L shape back cushion*2</p>	<p>G</p>  <p>Upper cover plate*2</p>	
<p>H</p>  <p>Bottom plate*2</p>	<p>I</p>  <p>Connector*8</p>	<p>J</p>  <p>Leg*8</p>	<p>U</p>  <p>Bolt*32 M8*16mm</p>	
<p>V</p>  <p>Bolt*16 M8*35mm</p>	<p>S</p>  <p>Washer*16</p>	<p>R</p>  <p>Plastic gasket *8</p>	<p>Y</p>  <p>Allen Key*2</p>	<p>Z</p>  <p>Connector*2</p>

Note: Please retain all boxes until you are certain that your product isn't damaged and that you do not wish to return it. Disposal of boxes may prevent our ability to resolve your request.

- ① Assemble the Side panel(C) to the Front panel(D).

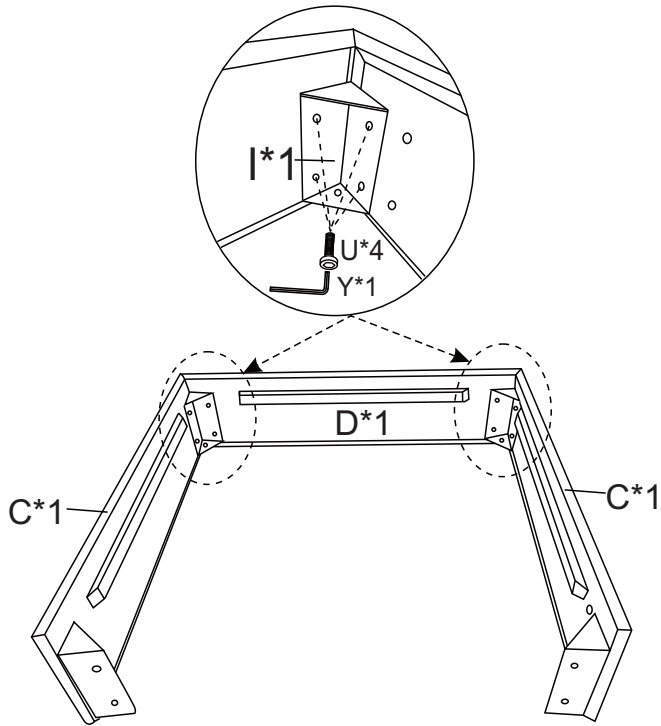

- ② Assemble the Back panel (E) to the frame.

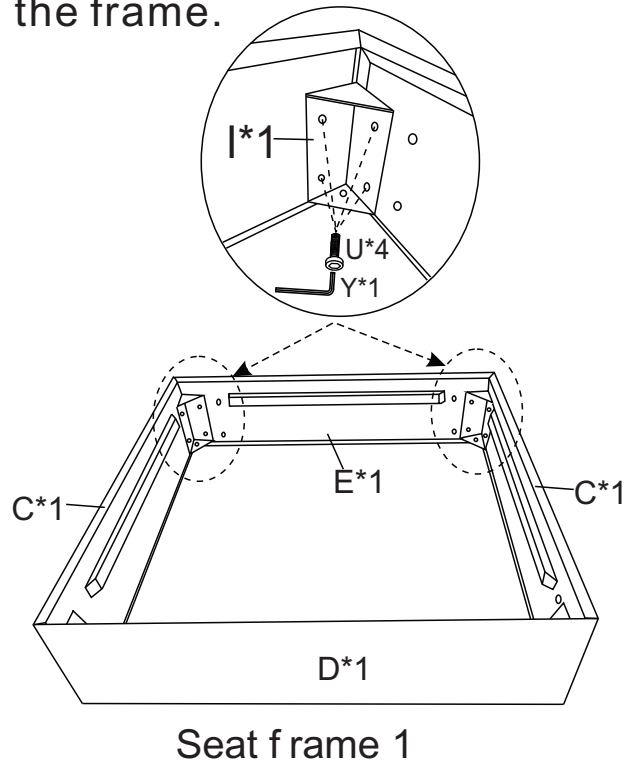

- ③ Assemble the Side panel(C) to the Front panel(D).

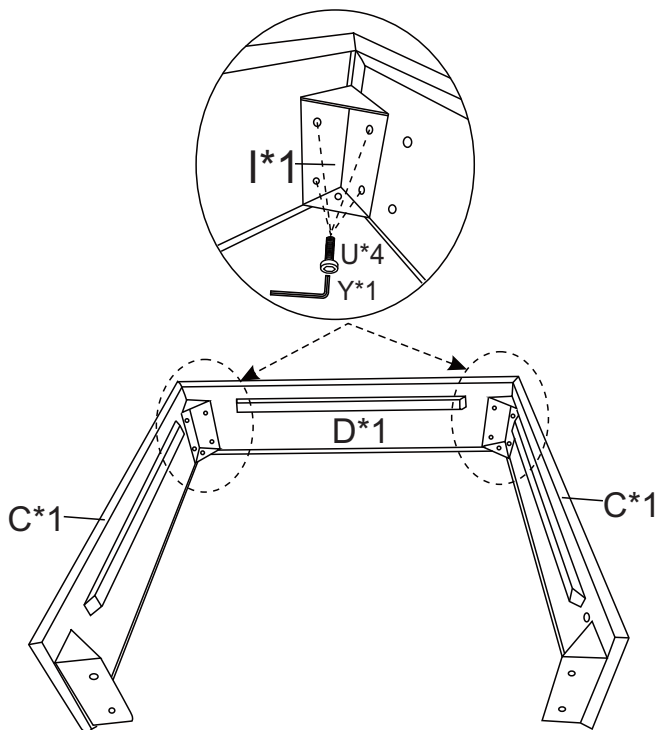

- ④ Assemble the Back panel (E) to the frame.

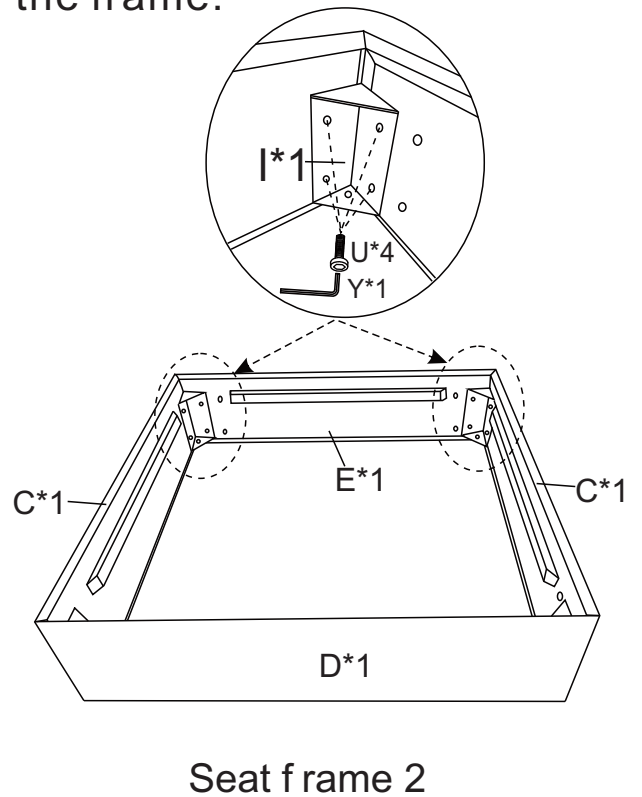

⑤ Assemble the Backrest(A) to seat frame with Washer(S) and Bolts (V) .

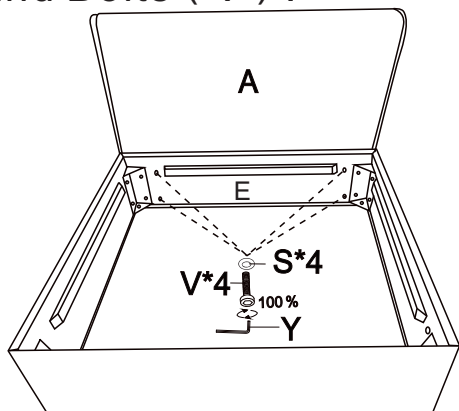

Backrest 1

⑥ Assemble the Backrest(A) to seat frame with Washer(S) and Bolts (V) .

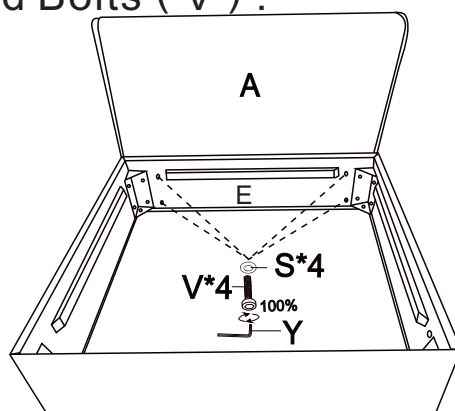

Backrest 2

⑦ Assemble the Armrest(K) to the seat frame with Washer (S) and Bolts(V) .

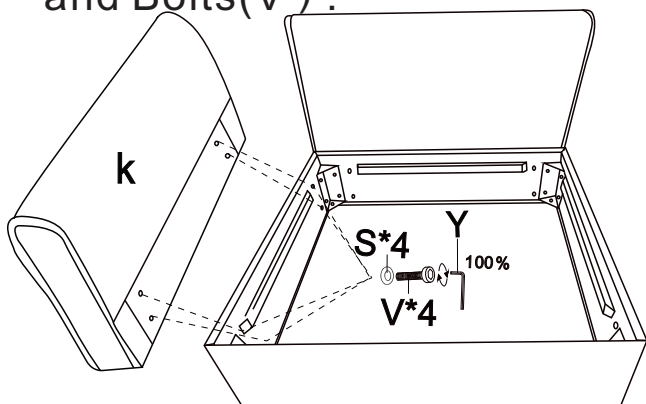

⑧ Assemble the Armrest(K) to the seat frame with Washer (S) and Bolts(V) .

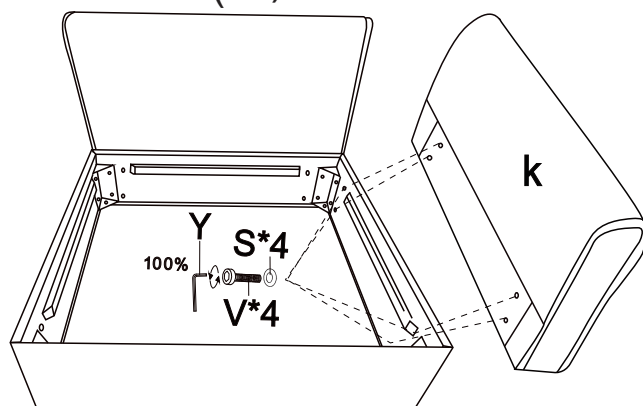

⑨ Place the Bottom plate(H) to the bottom of the seat frame.

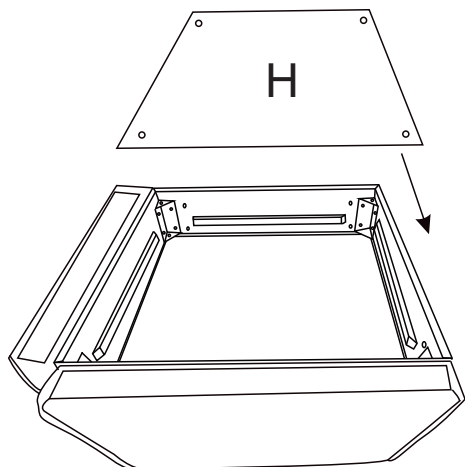

⑩ Place the Bottom plate(H) to the bottom of the seat frame.

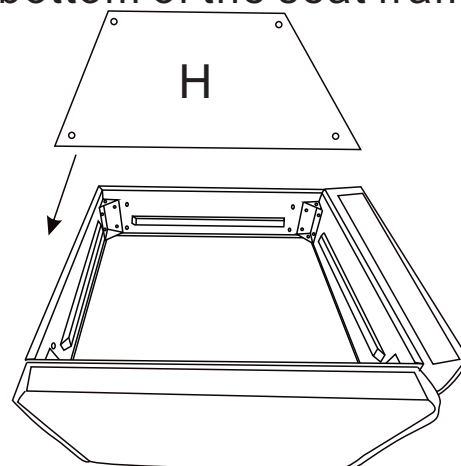

①① Assemble the Legs (J) into the Bottom plate(H) With Plastic gasket(R).

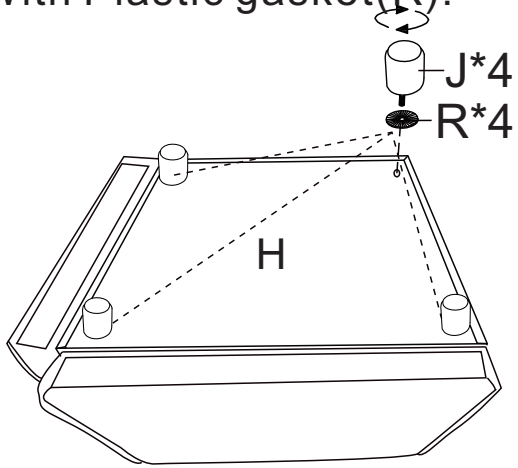

①② Assemble the Legs (J) into the Bottom plate(H) With Plastic gasket(R).

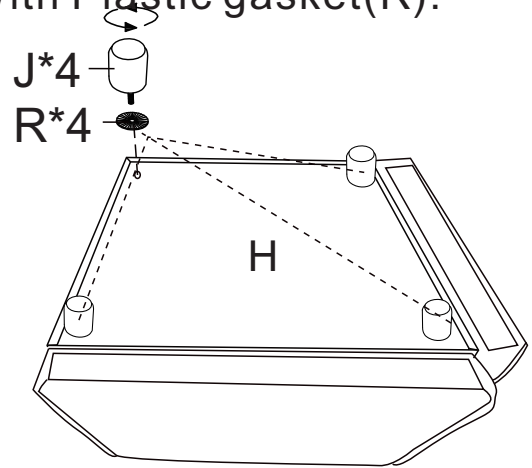

①③ Put the Upper cover plate(G) to the seat frame.

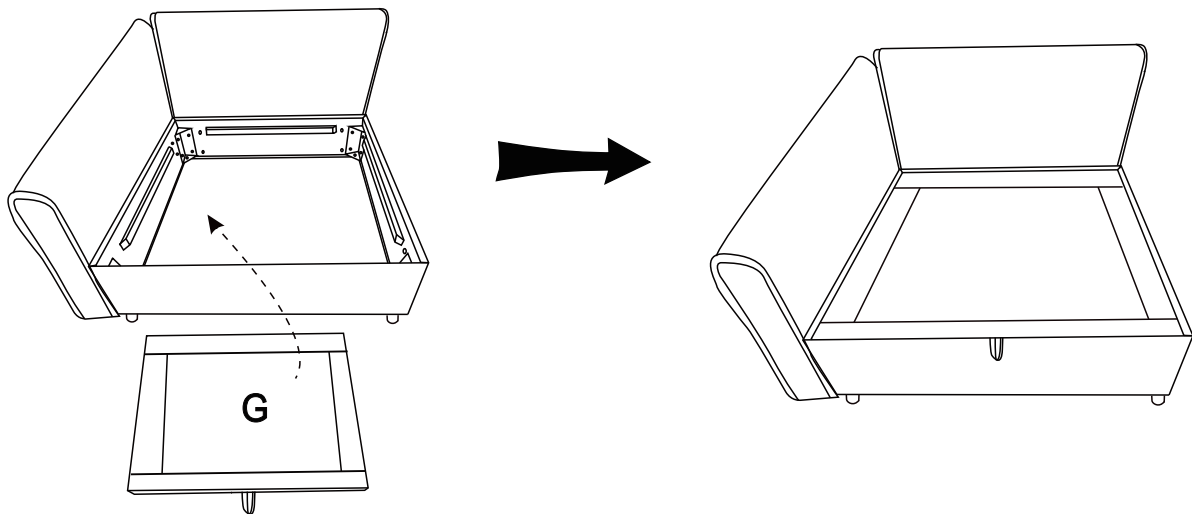

①④ Put the Upper cover plate(G) to the seat frame.

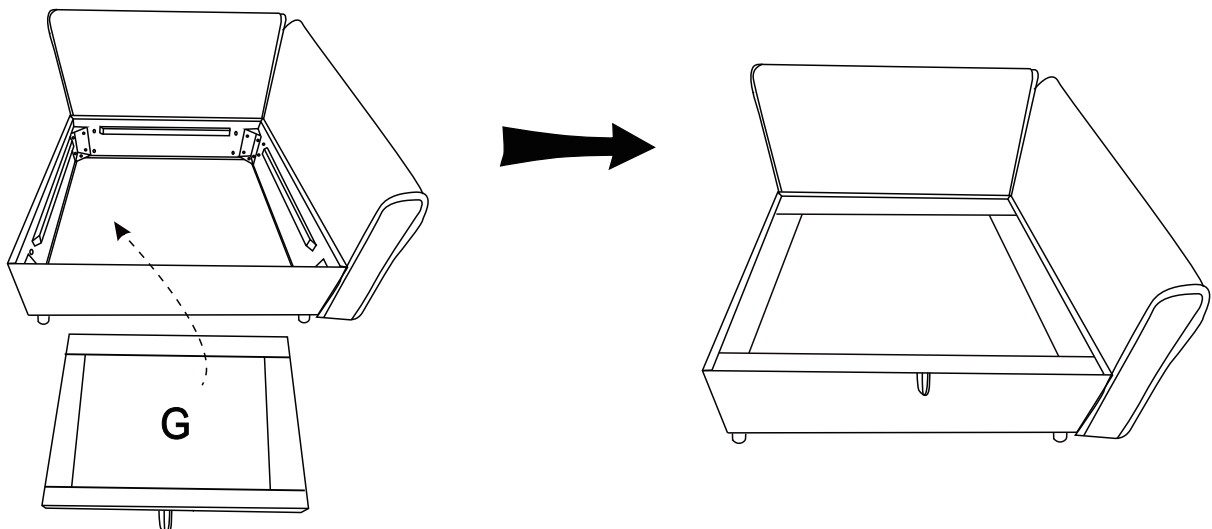

15 Fix the assemble sofa together with Connectors(Z).

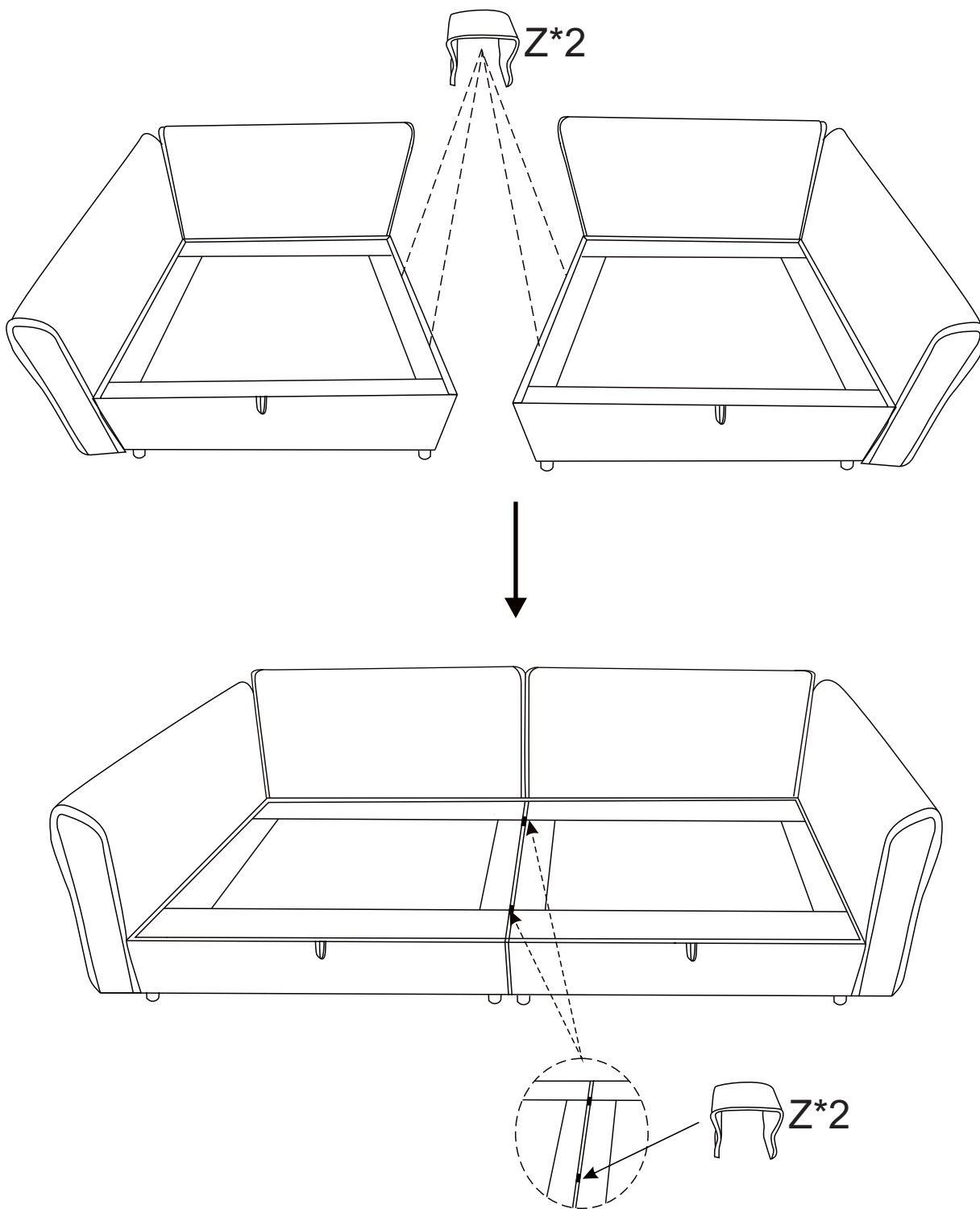

①⑥ Put the L shape back cushion(Q) and Seat cushion(B)to the sofa.

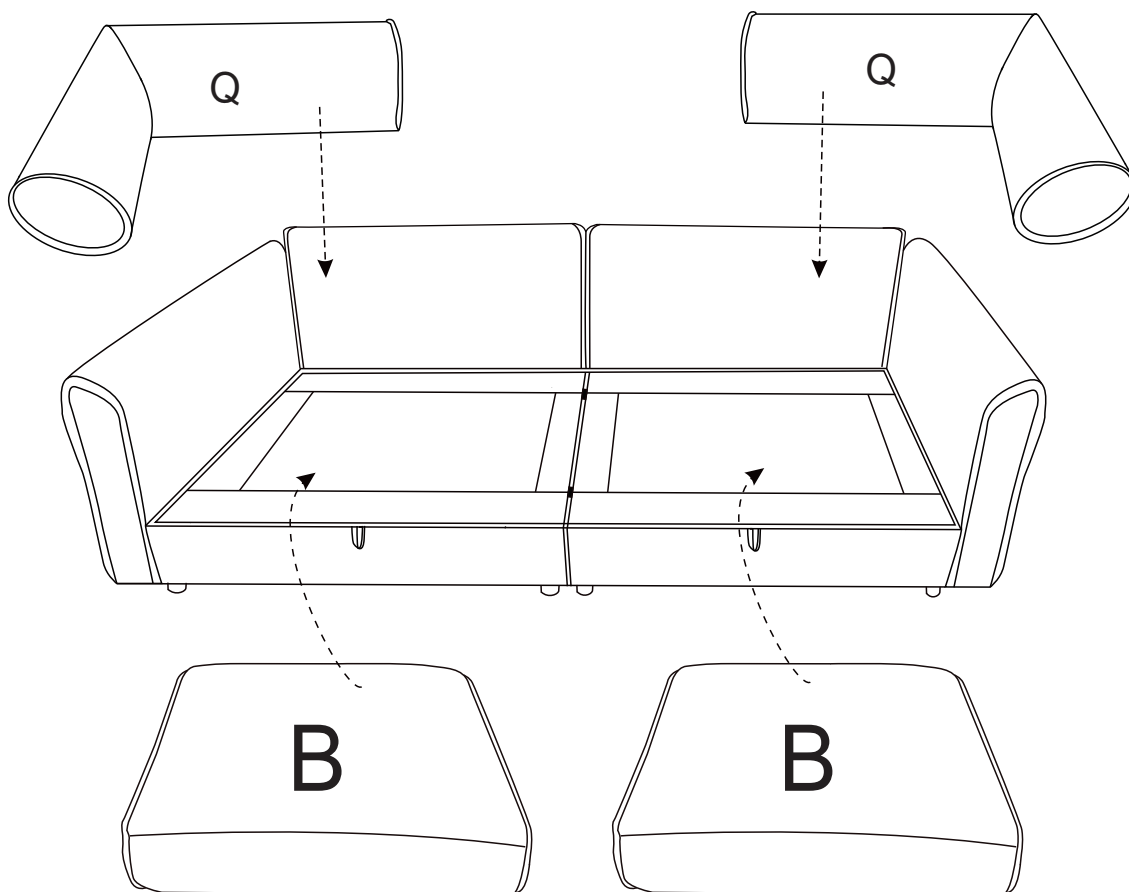



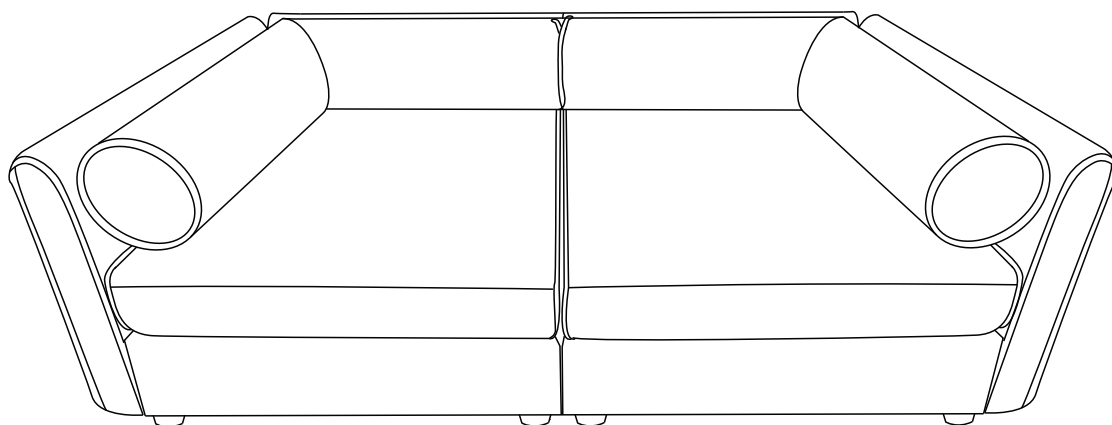



①⑦ Completed.

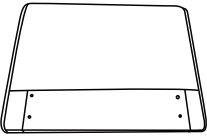
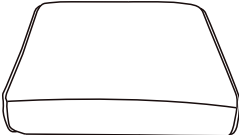
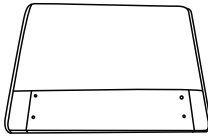
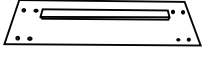
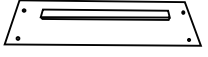
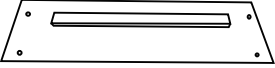
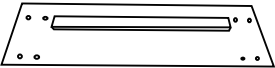

Assembly Instructions

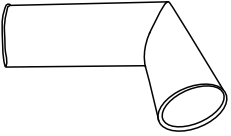
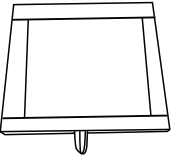
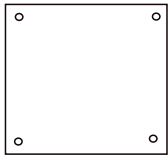
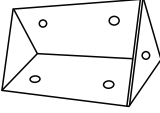
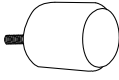
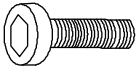
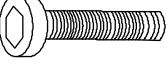
IF YOU BUY 3 SEATER SOFA
please follow below assembly instruction

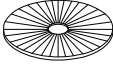
Parts List

<p>A</p>  <p>Backrest*3</p>	<p>B</p>  <p>Seat cushion*3</p>	<p>K</p>  <p>Armrest*2</p>	<p>C</p>  <p>Side panel*4</p>	<p>W</p>  <p>Side panel*2</p>
<p>D</p>  <p>Front panel*3</p>	<p>E</p>  <p>Back panel*3</p>	<p>F</p>  <p>Back cushion*1</p>	<p>Q</p>  <p>L shape back cushion*2</p>	
<p>G</p>  <p>Upper cover plate*3</p>	<p>H</p>  <p>Bottom plate*3</p>	<p>I</p>  <p>Connector*12</p>	<p>J</p>  <p>Leg*12</p>	<p>U</p>  <p>Bolt*48 M8*16mm</p>
<p>V</p>  <p>Bolt*20 M8*35mm</p>	<p>S</p>  <p>Washer*20</p>	<p>R</p>  <p>Plastic gasket *12</p>	<p>Y</p>  <p>Allen Key*3</p>	<p>Z</p>  <p>Connector*4</p>

Note: Please retain all boxes until you are certain that your product isn't damaged and that you do not wish to return it. Disposal of boxes may prevent our ability to resolve your request.

- ① Assemble the Side panel(C) to the Front panel(D).

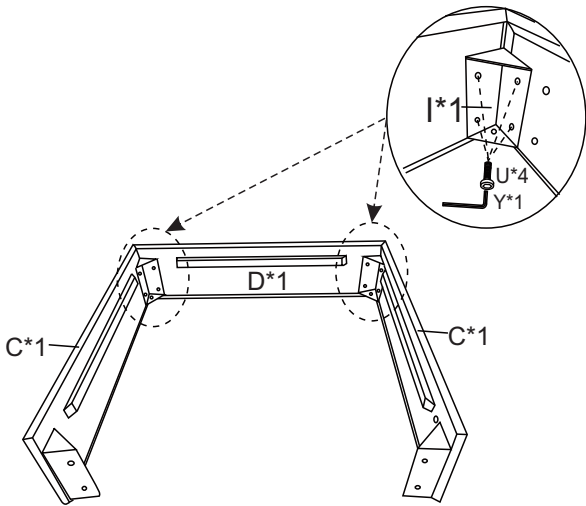

- ② Assemble the Back panel (E) to the frame.

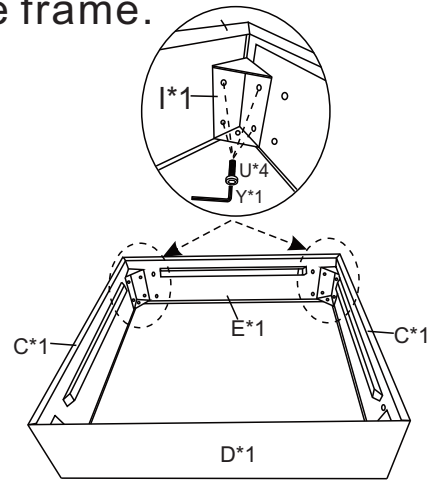

Seat f rame 1

- ③ Assemble the Side panel(C) to the Front panel(D).

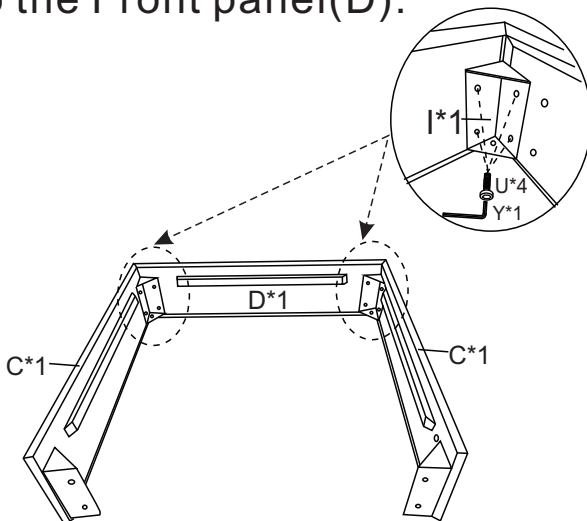

- ④ Assemble the Back panel (E) to the frame.

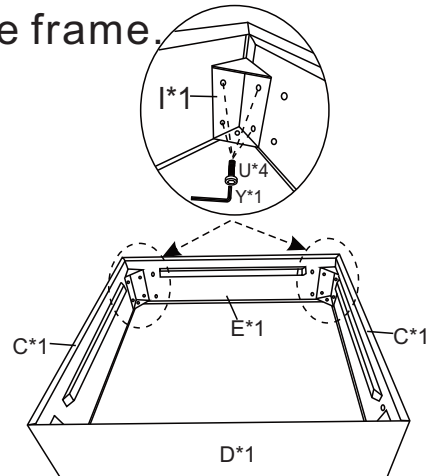

Seat f rame 2

- ⑤ Assemble the Side panel(W) to the Front panel(D).

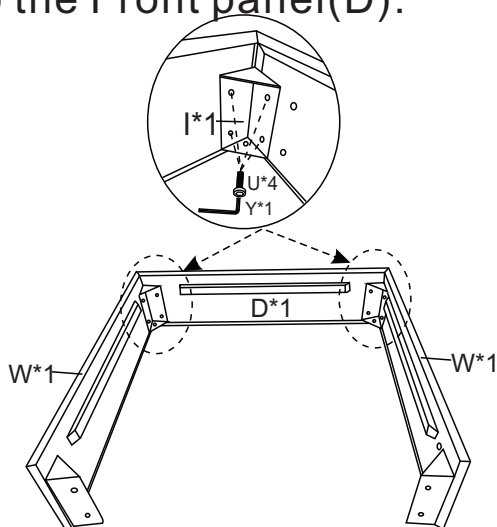

- ⑥ Assemble the Back panel (E) to the frame.

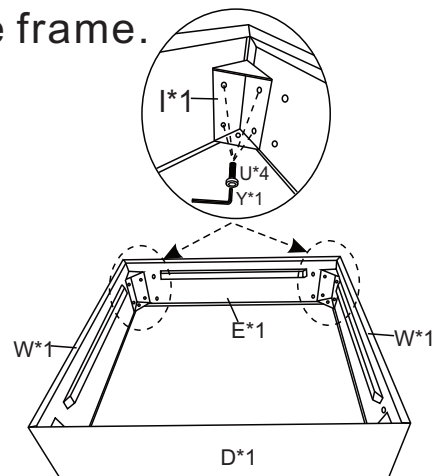

Seat f rame 3

⑦ Assemble the Backrest(A) to seat frame and Bolts (V) .

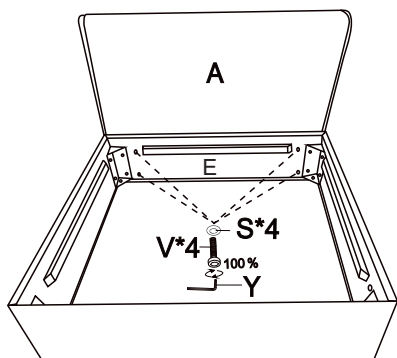

Backrest 1

⑧ Assemble the Backrest(A) to seat frame and Bolts (V) .

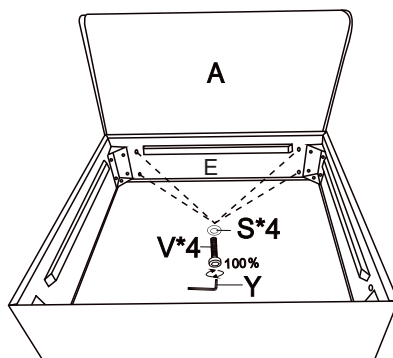

Backrest 2

⑨ Assemble the Backrest(A) to seat frame and Bolts (V) .

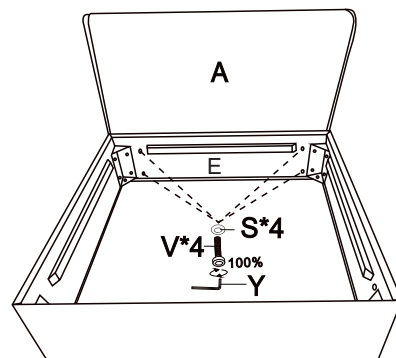

Backrest 3

⑩ Assemble the Armrest(K) to the seat frame with Washer (S) and Bolts(V) .

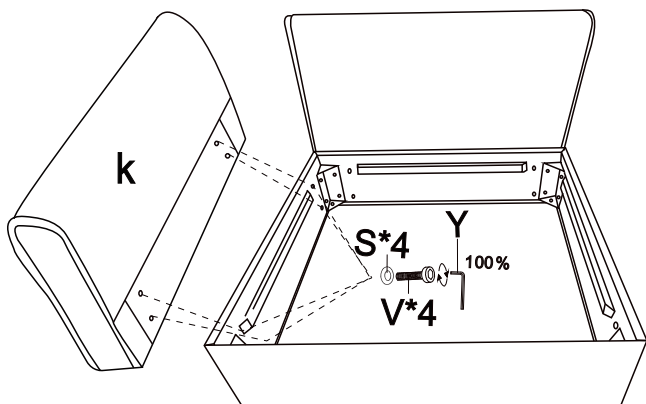

⑪ Assemble the Armrest(K) to the seat frame with Washer (S) and Bolts(V) .

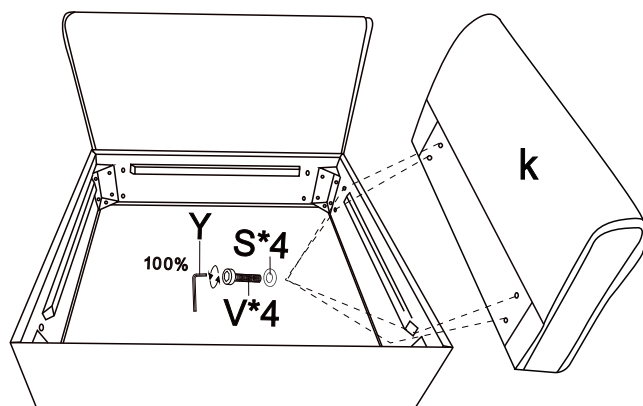

⑫ Place the Bottom plate(H) to the bottom of the seat frame.

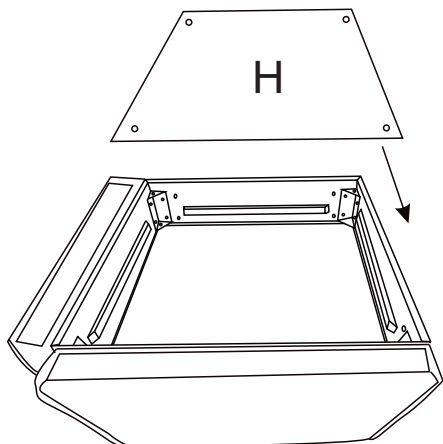

⑬ Place the Bottom plate(H) to the bottom of the seat frame.

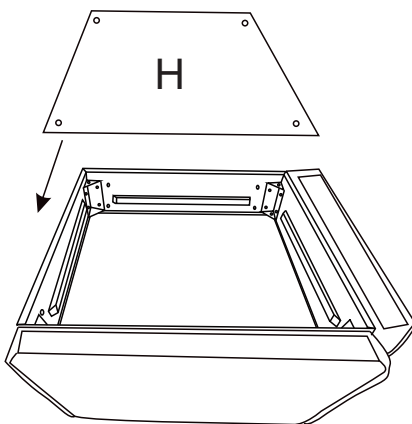

⑭ Place the Bottom plate(H) to the bottom of the seat frame.

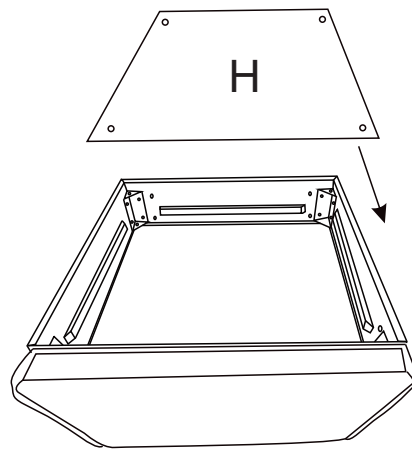

⑮ Assemble the Legs (J) into the Bottom plate(H) With Plastic gasket(R).

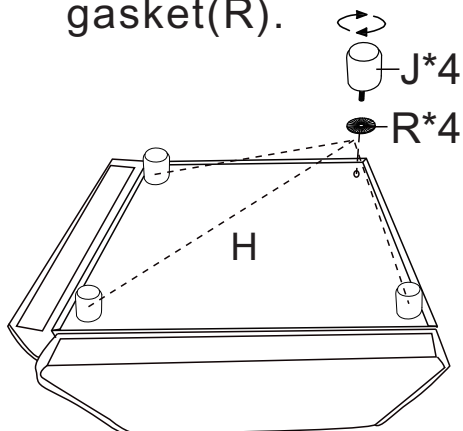

⑯ Assemble the Legs (J) into the Bottom plate(H) With Plastic gasket(R).

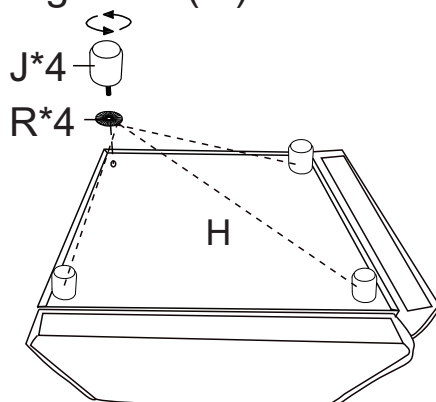

⑰ Assemble the Legs (J) into the Bottom plate(H) With Plastic gasket(R).

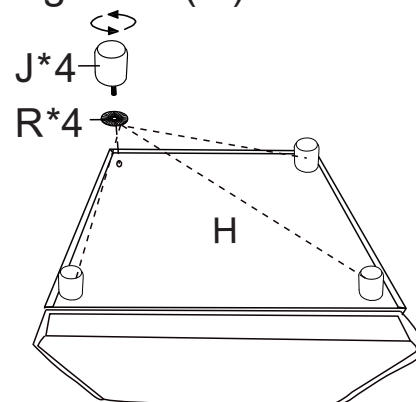

⑱ Put the Upper cover plate(G) to the seat frame.

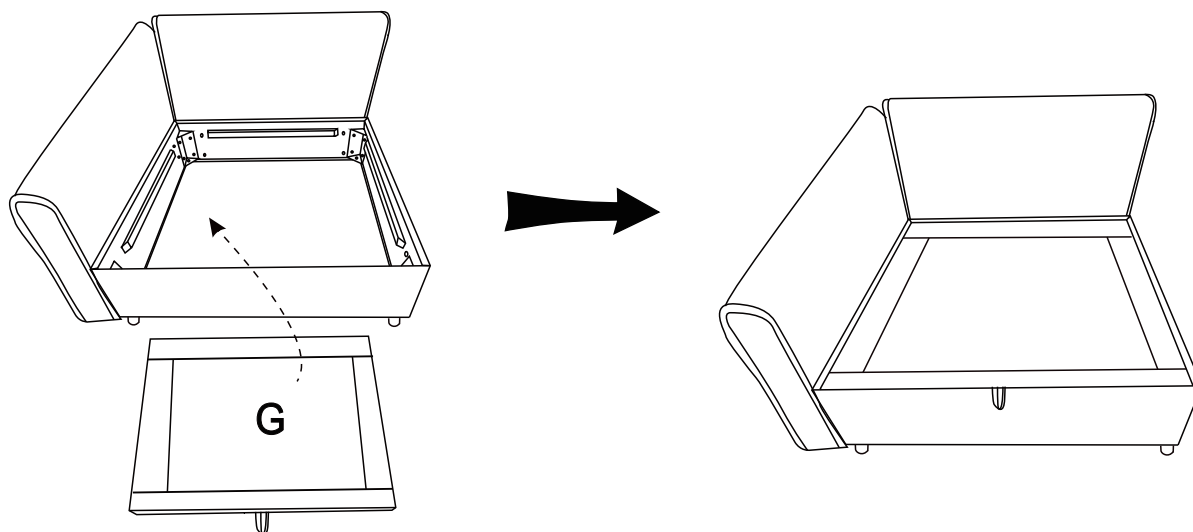

⑲ Put the Upper cover plate(G) to the seat frame.

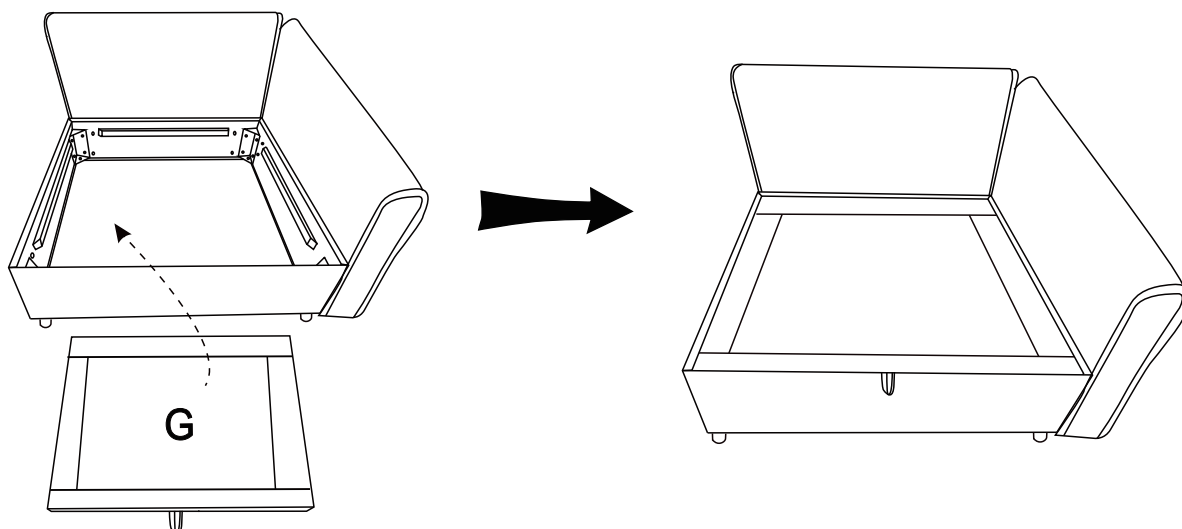

②0 Put the Upper cover plate(G) to the seat frame.

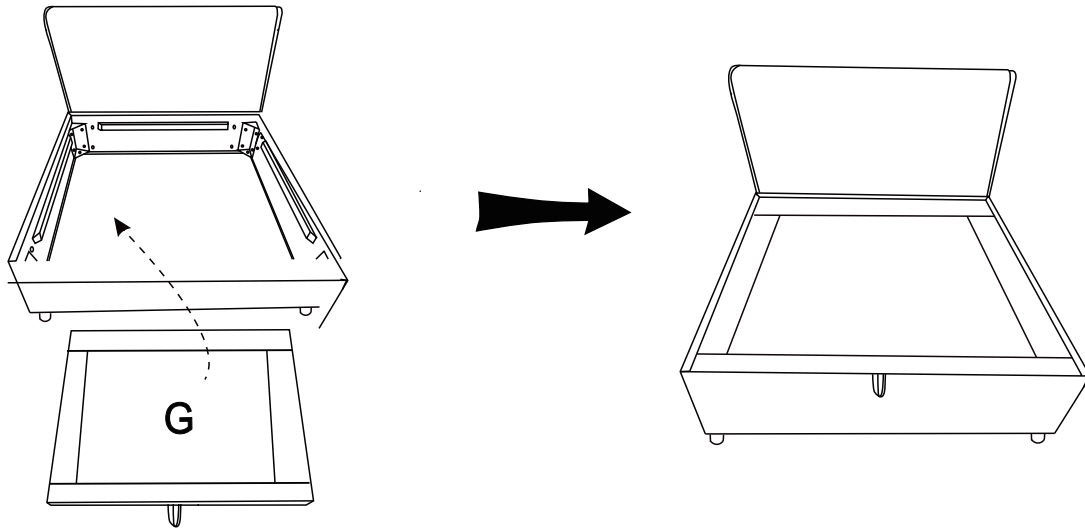

②1 Fix the assemble sofa together with Connectors(Z).

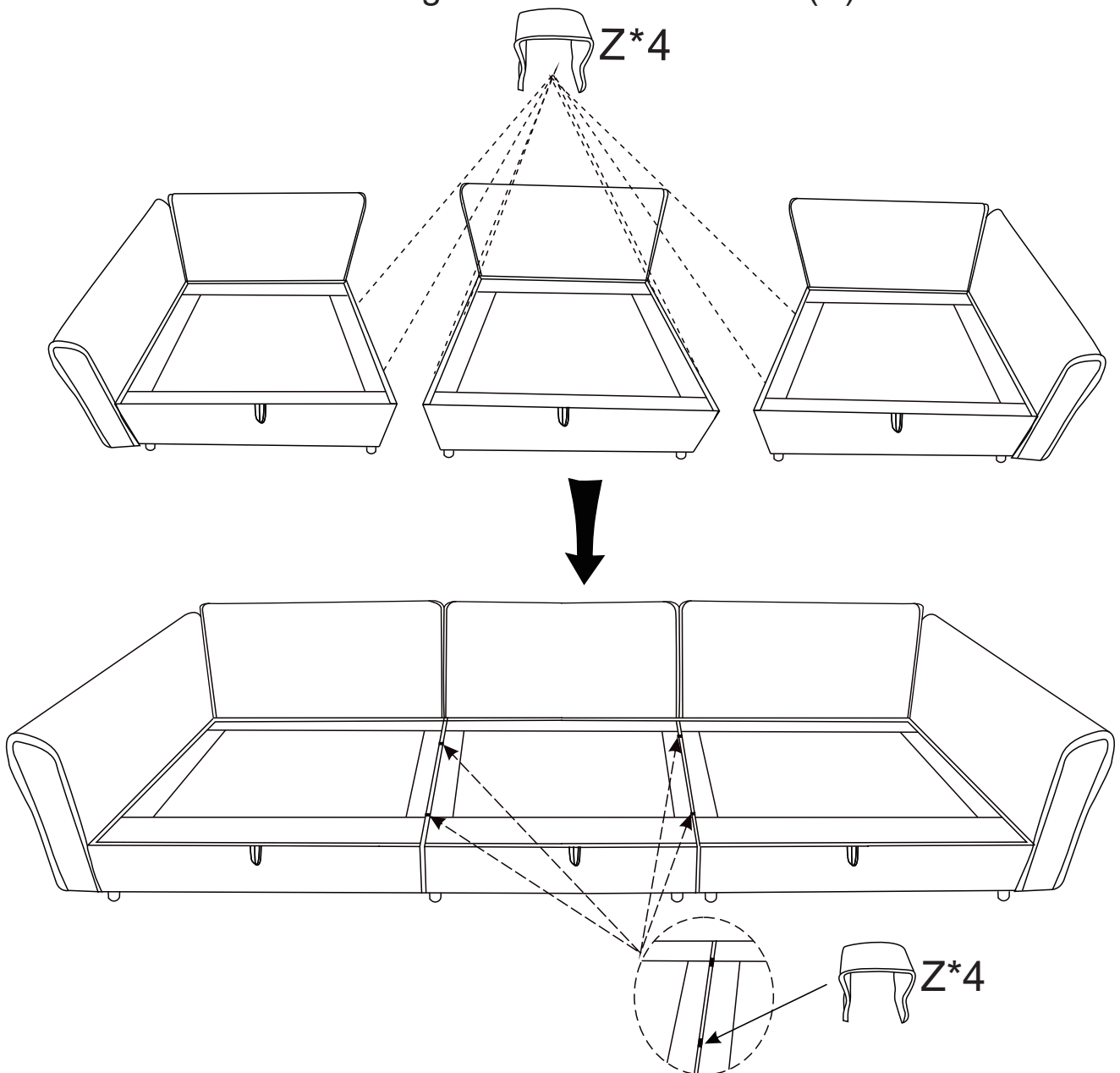

②② Put the L shape back cushion(Q) and back cushion(F) and Seat cushion(B)to the sofa.

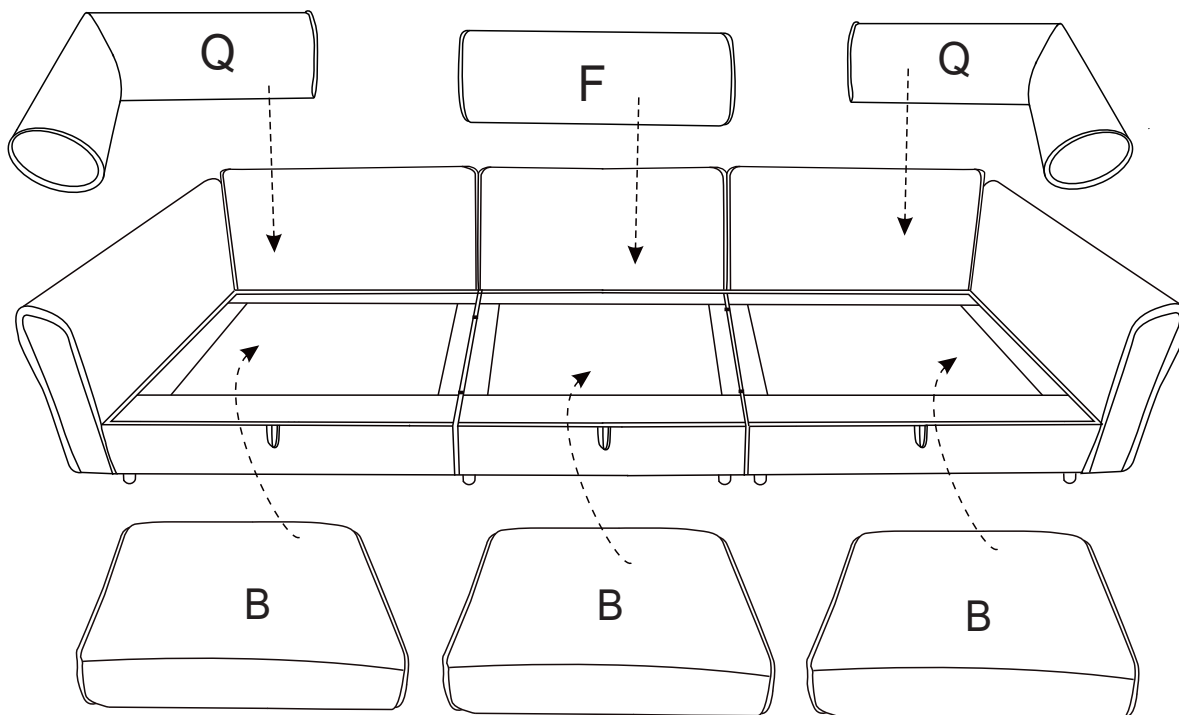



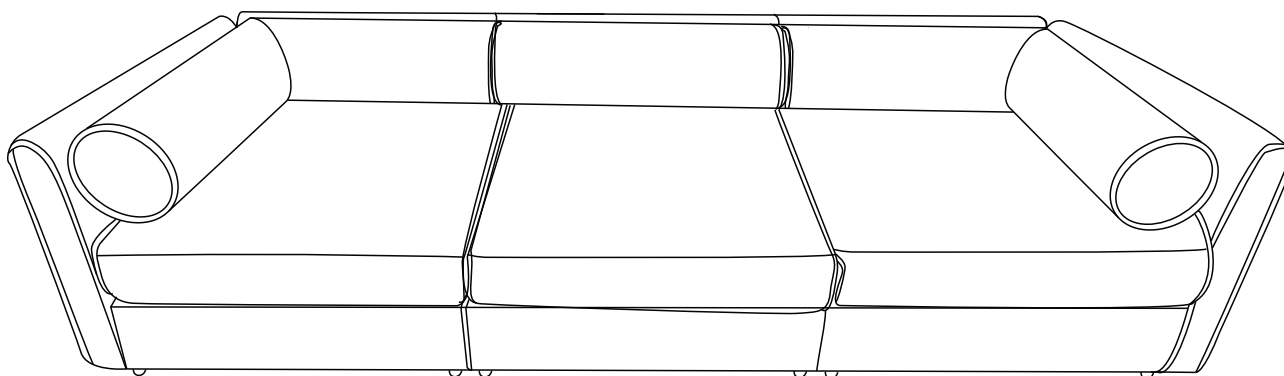







②③ Completed.

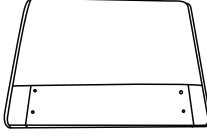
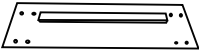

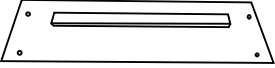
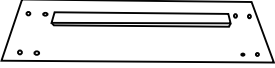
Assembly Instructions

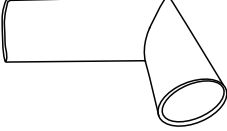
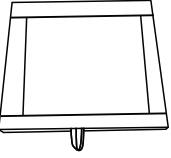
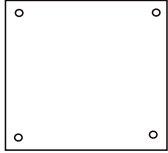
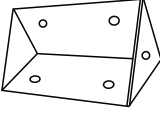
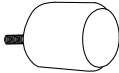
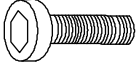
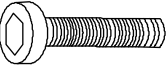
IF YOU BUY 4 SEATER SOFA
please follow below assembly instruction

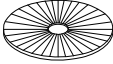
Parts List

<p>A</p>  <p>Backrest*4</p>	<p>B</p>  <p>Seat cushion*3</p>	<p>K</p>  <p>Armrest*2</p>	<p>C</p>  <p>Side panel*4</p>	<p>W</p>  <p>Side panel*4</p>
<p>D</p>  <p>Front panel*4</p>	<p>E</p>  <p>Back panel*4</p>	<p>F</p>  <p>Back cushion*2</p>	<p>Q</p>  <p>L shape back cushion*2</p>	
<p>G</p>  <p>Upper cover plate*4</p>	<p>H</p>  <p>Bottom plate*4</p>	<p>I</p>  <p>Connector*16</p>	<p>J</p>  <p>Leg*16</p>	<p>U</p>  <p>Bolt*64 M8*16mm</p>
<p>V</p>  <p>Bolt*24 M8*35mm</p>	<p>S</p>  <p>Washer*24</p>	<p>R</p>  <p>Plastic gasket *16</p>	<p>Y</p>  <p>Allen Key*4</p>	<p>Z</p>  <p>Connector*6</p>

Note: Please retain all boxes until you are certain that your product isn't damaged and that you do not wish to return it. Disposal of boxes may prevent our ability to resolve your request.

- ① Assemble the Side panel(C) to the Front panel(D).

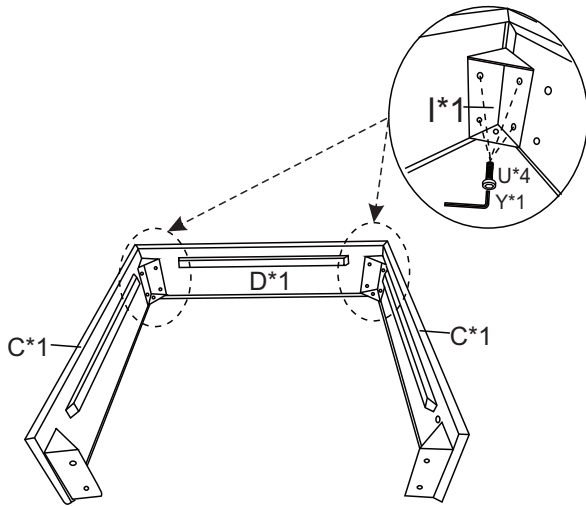

- ② Assemble the Back panel (E) to the frame.

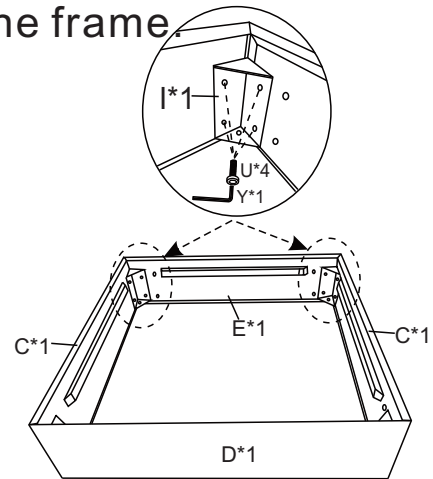

Seat f r a m e 1

- ③ Assemble the Side panel(C) to the Front panel(D).

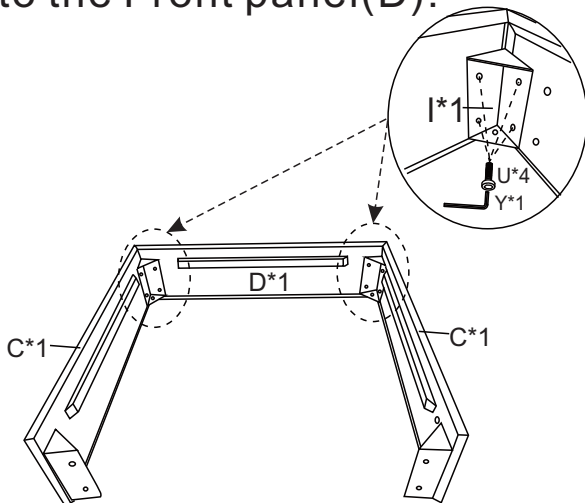

- ④ Assemble the Back panel (E) to the frame.

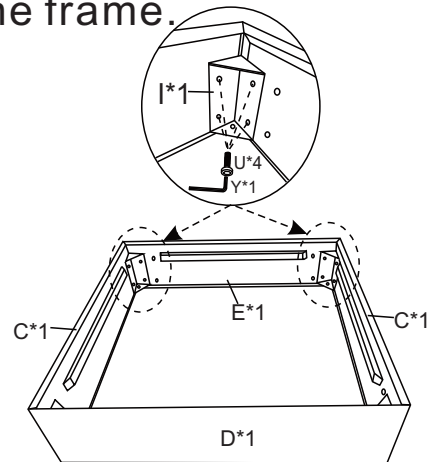

Seat f r a m e 2

- ⑤ Assemble the Side panel(W) to the Front panel(D).

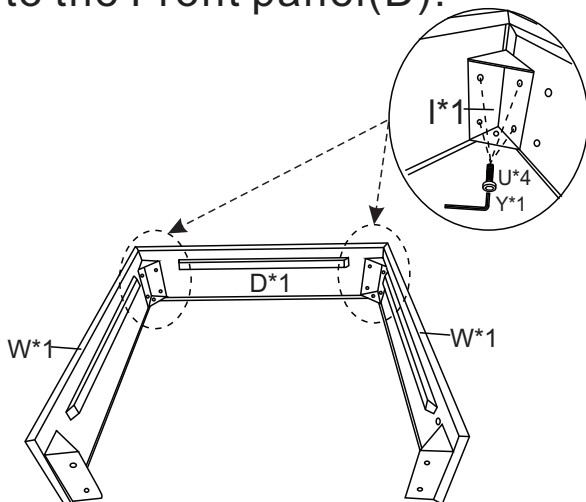

- ⑥ Assemble the Back panel (E) to the frame.

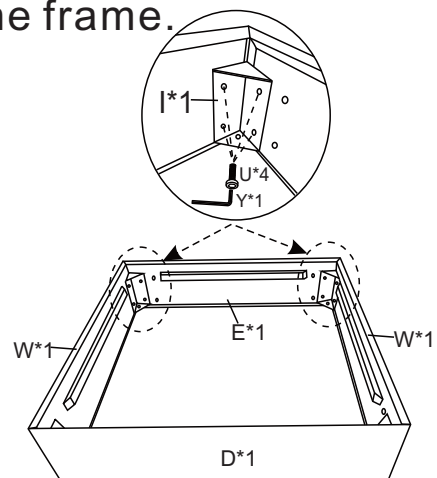

Seat f r a m e 3

⑦ Assemble the Side panel(W) to the Front panel(D).

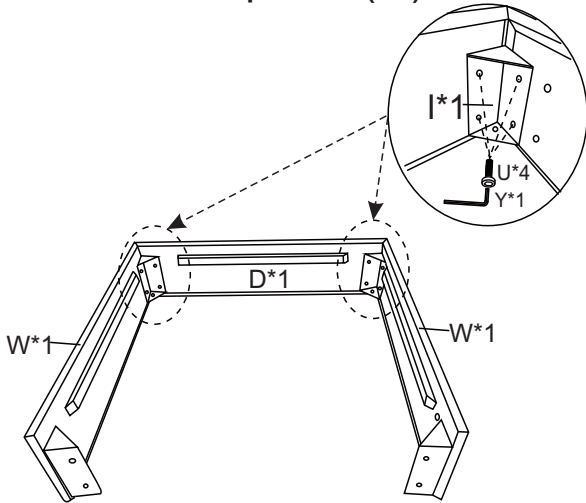

⑧ Assemble the Back panel (E) to the frame.

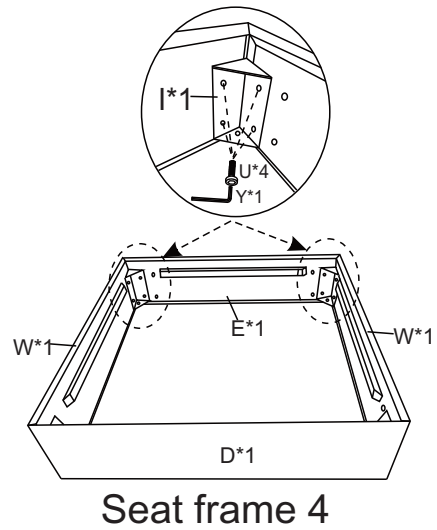

⑨ Assemble the Backrest(A) to seat frame with Washer(S) and Bolts (V).

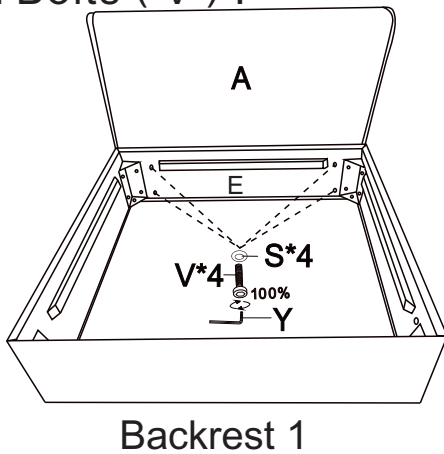

⑩ Assemble the Backrest(A) to seat frame with Washer(S) and Bolts (V).

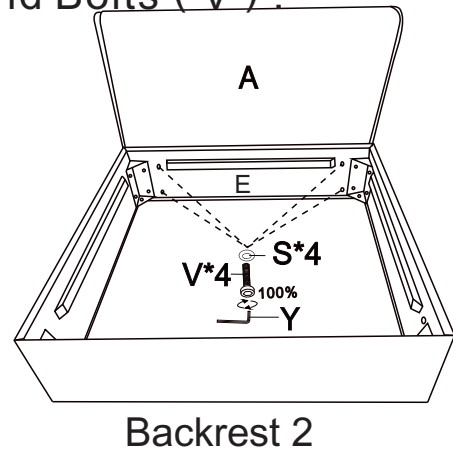

⑪ Assemble the Backrest(A) to seat frame with Washer(S) and Bolts (V).

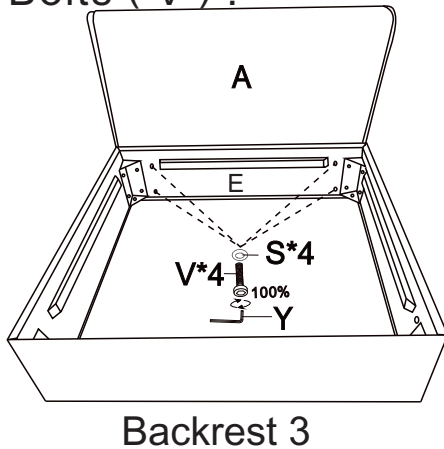

⑫ Assemble the Backrest(A) to seat frame with Washer(S) and Bolts (V).

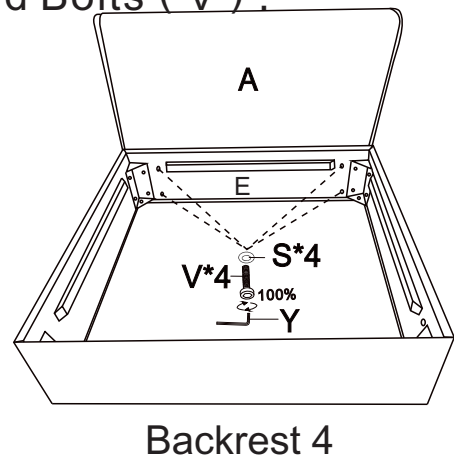

⑬ Assemble the Armrest(K) to the seat frame with Washer (S) and Bolts(V) .

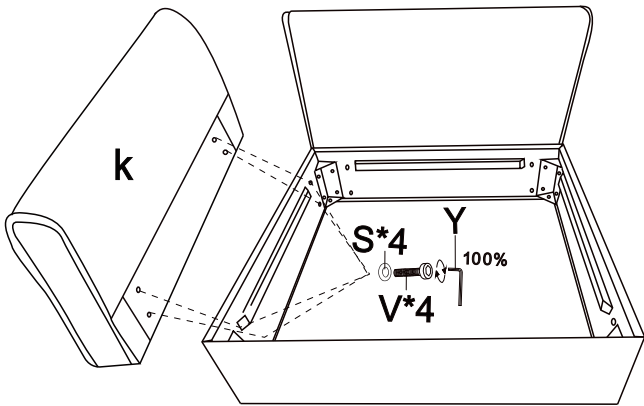

⑭ Assemble the Armrest(K) to the seat frame with Washer (S) and Bolts(V) .

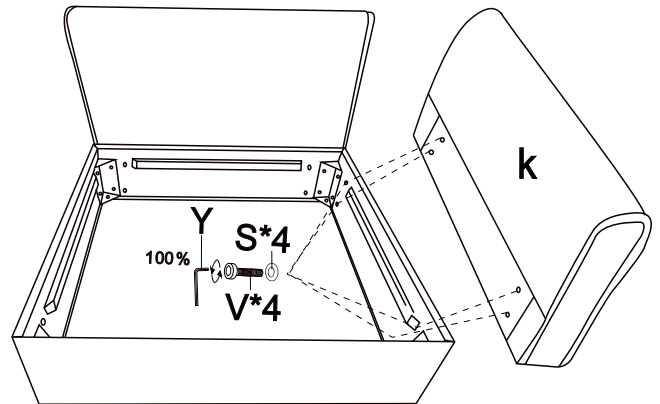

⑮ Place the Bottom plate(H) to the bottom of the seat frame.

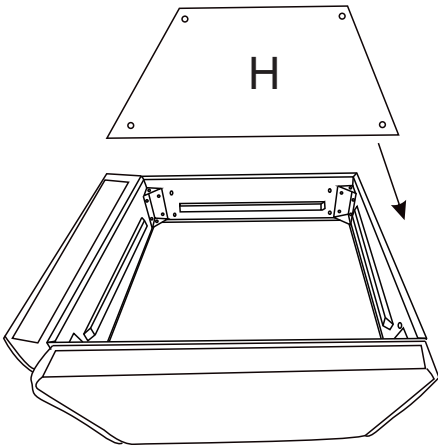

⑯ Place the Bottom plate(H) to the bottom of the seat frame.

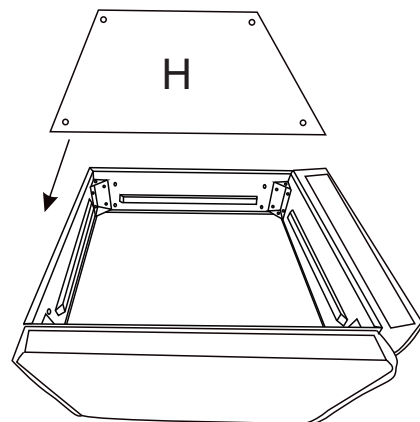

⑰ Place the Bottom plate(H) to the bottom of the seat frame.

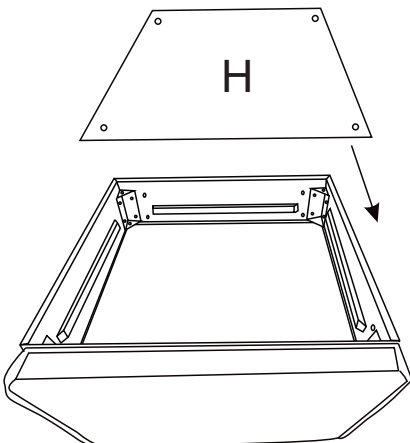

⑱ Place the Bottom plate(H) to the bottom of the seat frame.

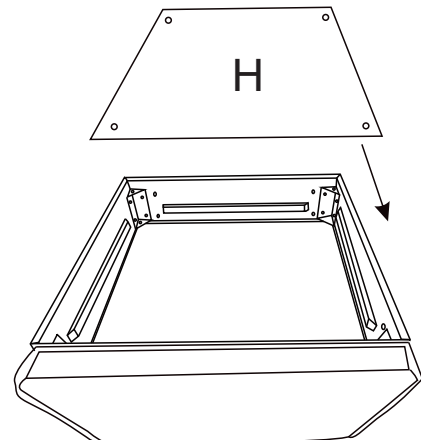

19 Assemble the Legs (J) into the Bottom plate(H) With Plastic gasket(R).

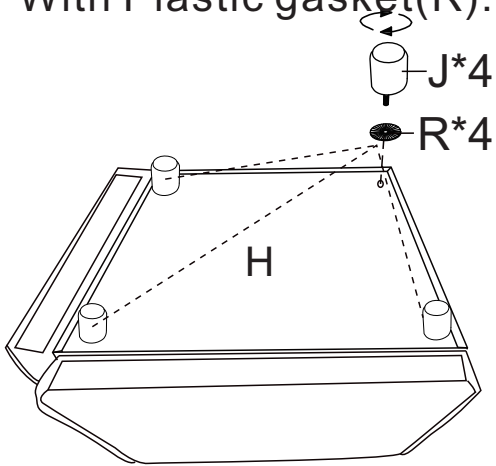

20 Assemble the Legs (J) into the Bottom plate(H) With Plastic gasket(R).

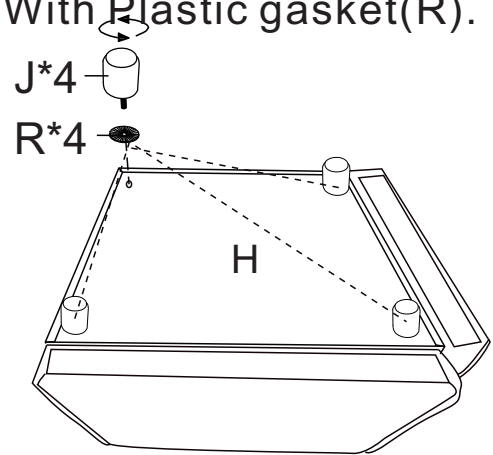

21 Assemble the Legs (J) into the Bottom plate(H) With Plastic gasket(R).

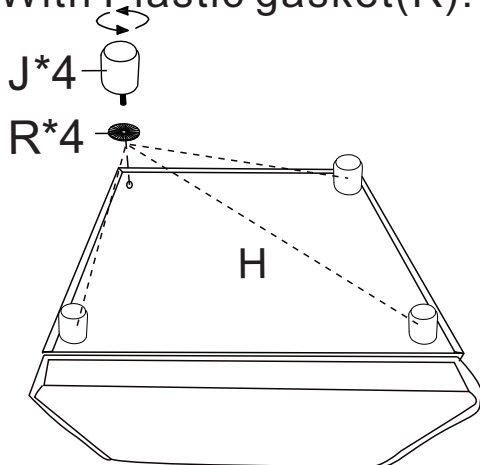

22 Assemble the Legs (J) into the Bottom plate(H) With Plastic gasket(R).

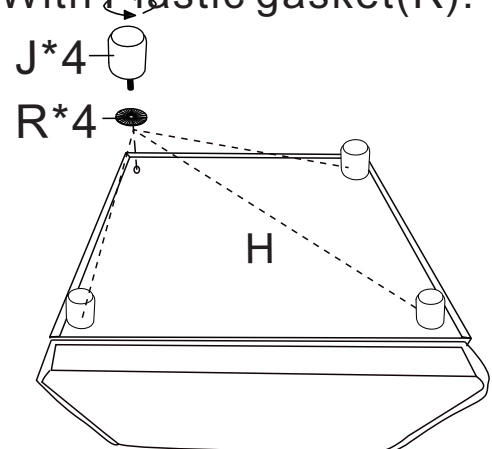

23 Put the Upper cover plate(G) to the seat frame.

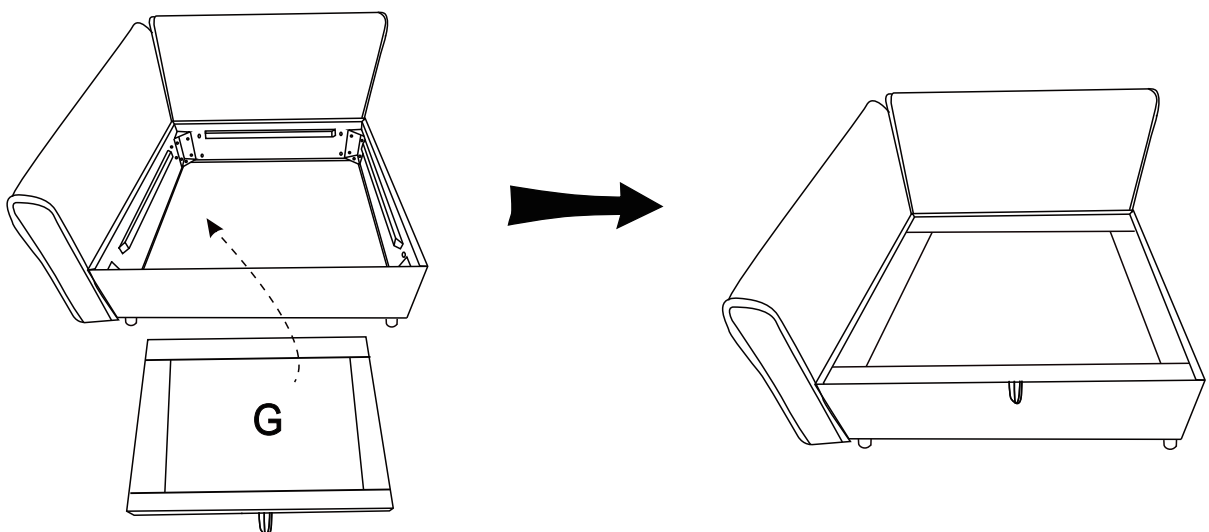

②④ Put the Upper cover plate(G) to the seat frame.

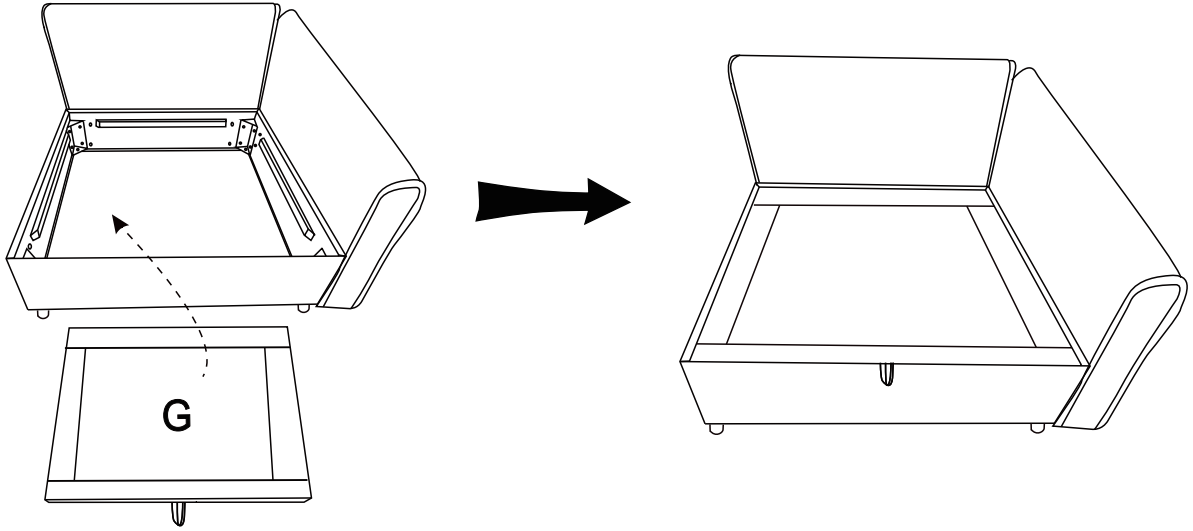

②⑤ Put the Upper cover plate(G) to the seat frame.

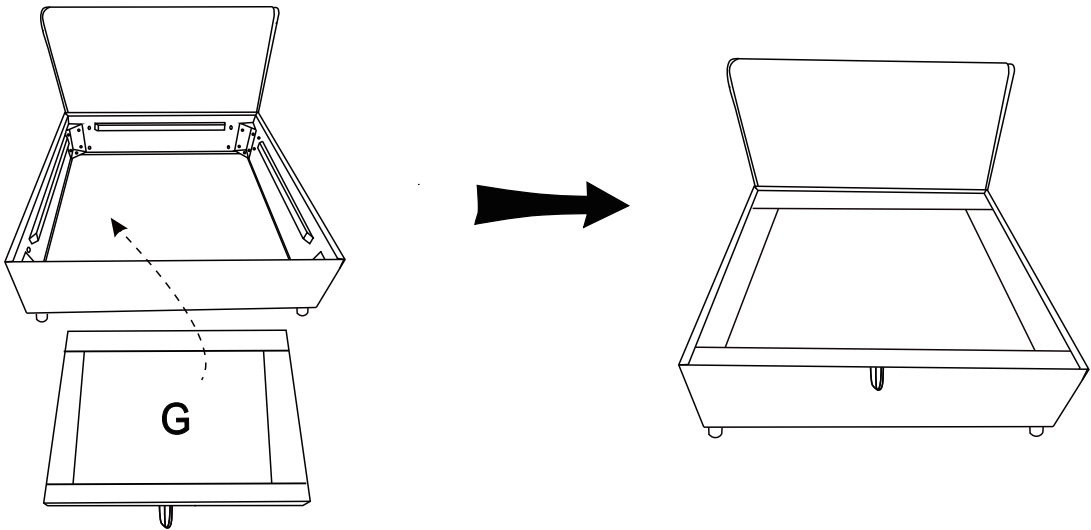

②⑥ Put the Upper cover plate(G) to the seat frame.

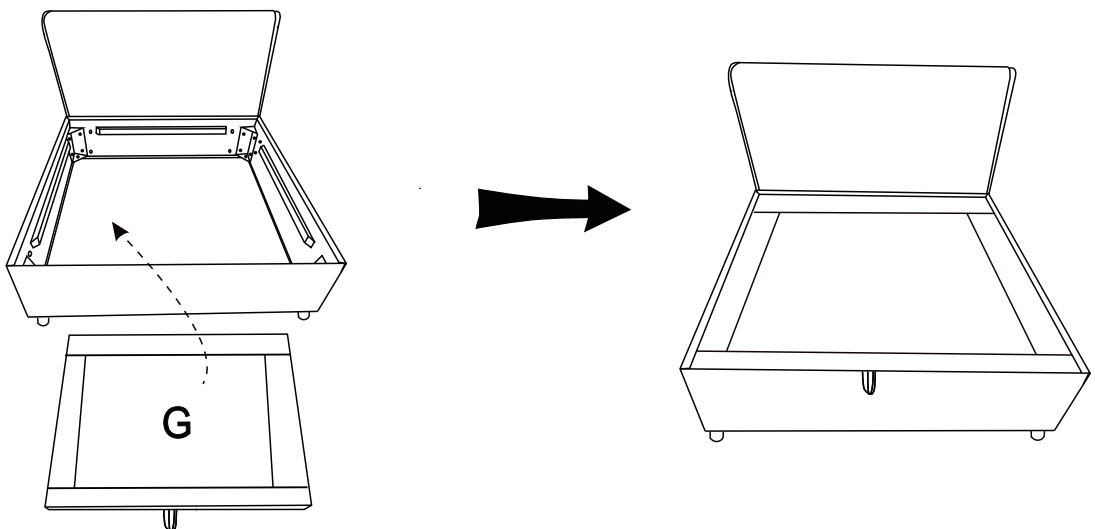

27 Fix the assemble sofa together with Connectors(Z).

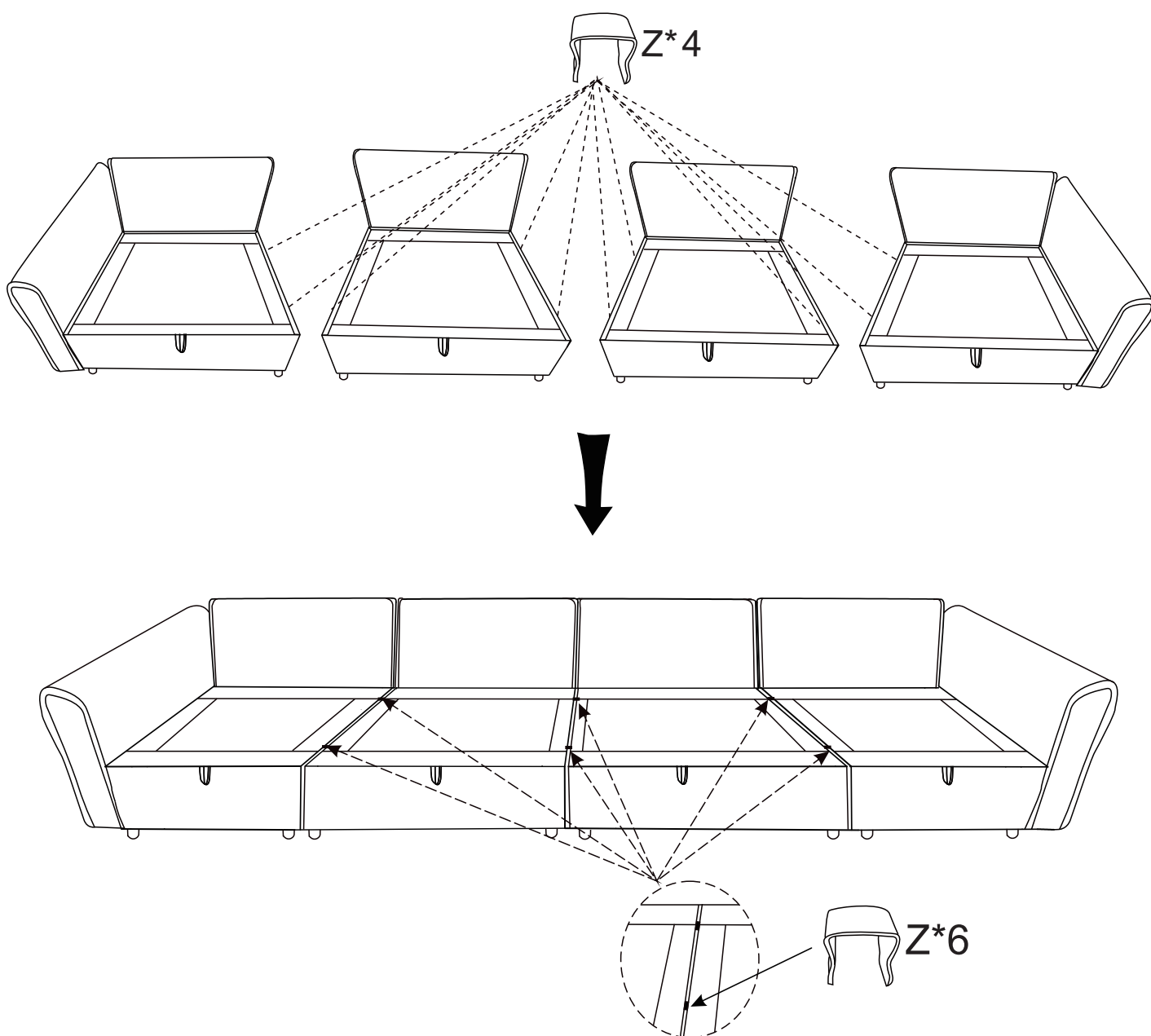

28 Put the L shape back cushion(Q) and back cushion(F) and Seat cushion(B) to the sofa.

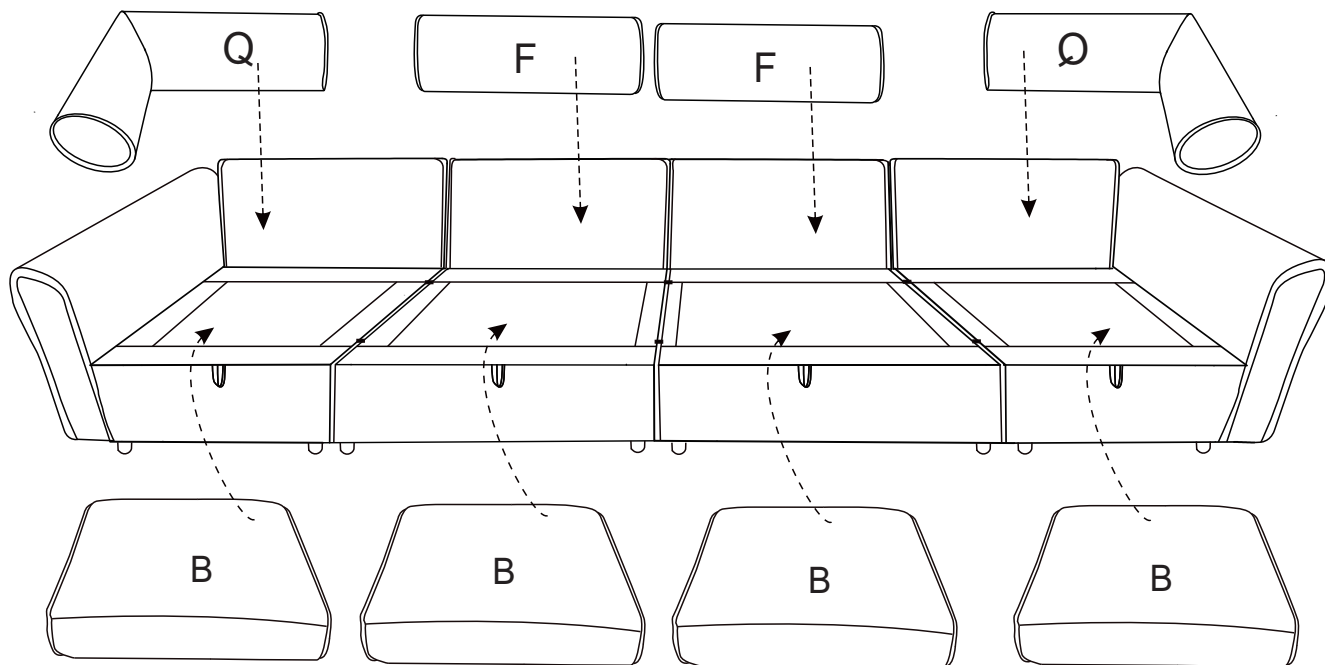

29 Completed.

