

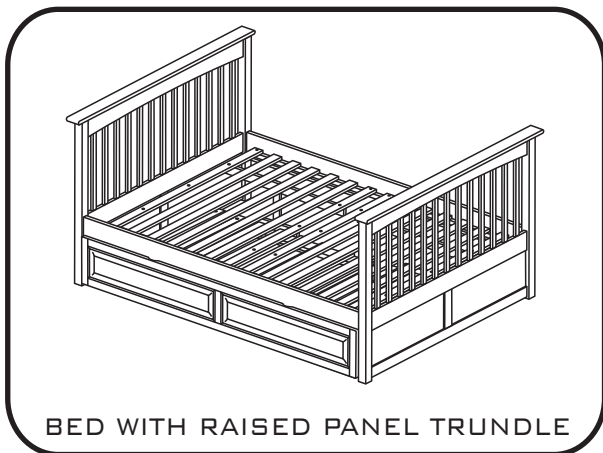

PANEL TRUNDLE

ASSEMBLY INSTRUCTIONS

Thank you for choosing our Panel Trundle.
 This practical design offers the utmost in versatility.
 Before assembling your Trundle, please read through these instructions carefully. Familiarizing yourself with the different parts.

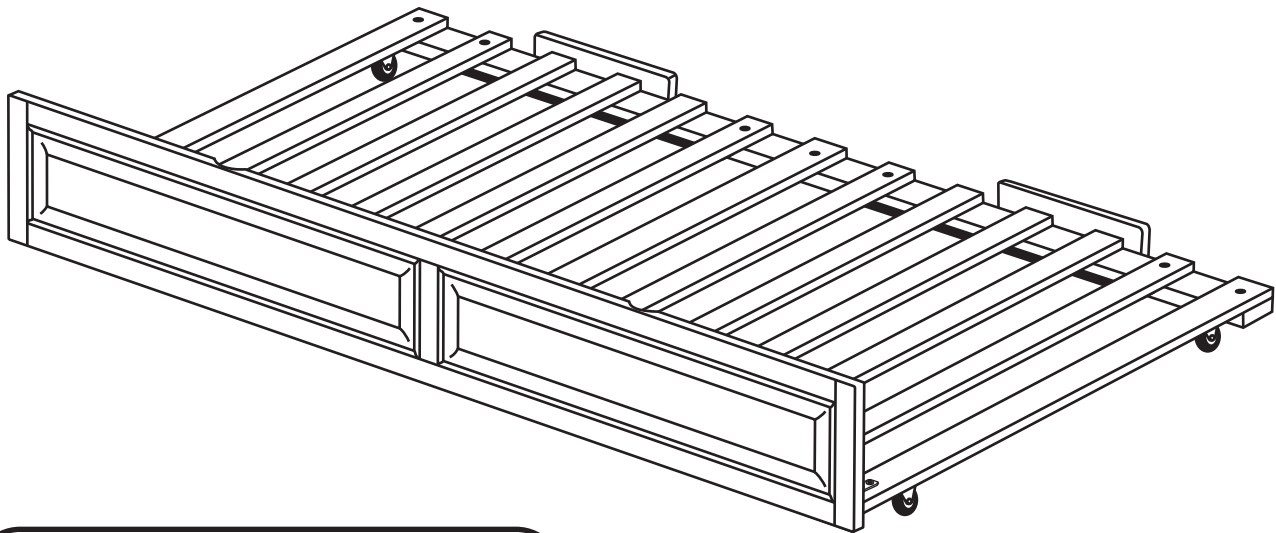

BED WITH RAISED PANEL TRUNDLE



Adult Assembly

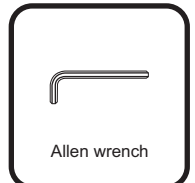

Allen wrench

HARDWARE

NOTE: WE INCLUDE SPARE HARDWARE IN CASE THE ALLEN WRENCH, JCB OR BARREL NUT ARE DAMAGED DURING ASSEMBLY.

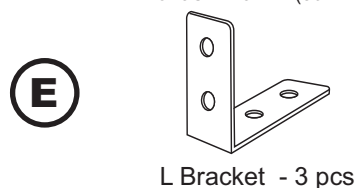
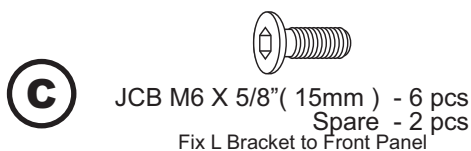
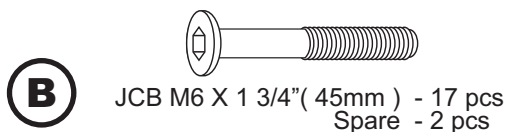
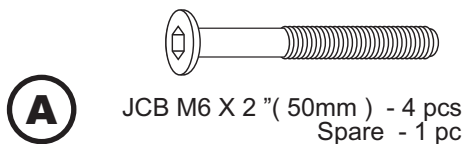

PARTS LIST

01	HARDWARE	1 BOX	05	RIGHT SIDE CROSS RAIL	1 PC
02	FRONT PANEL	1 PC	06	LEFT SIDE CROSS RAIL	1 PC
03	FRONT RAIL	1 PC	07	CENTER CROSS RAIL	1 PC
04	BACK RAIL	1 PC	08	BACK BOARDS	2 PCS
			09	SLATS	2 SETS

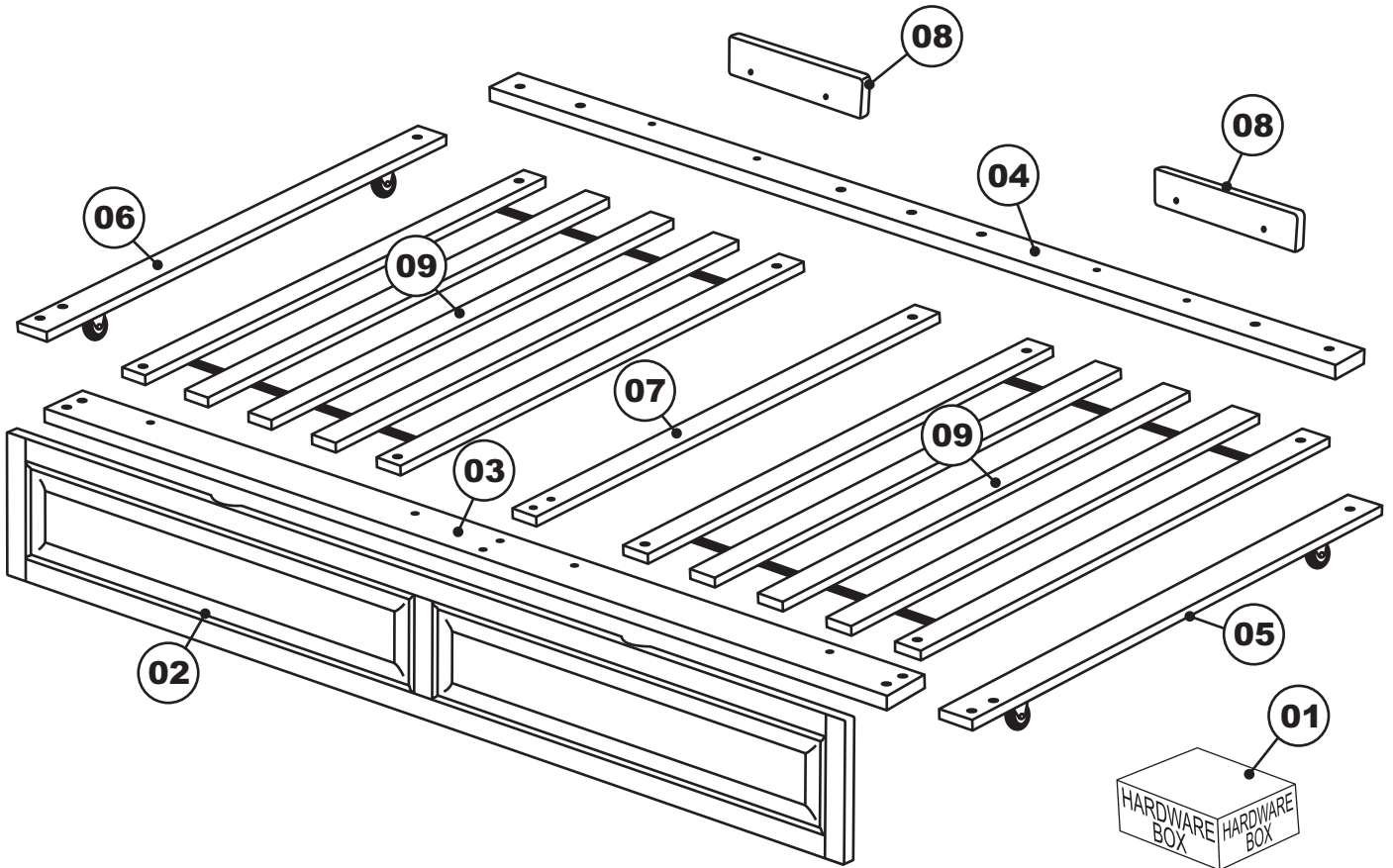

STEP 1

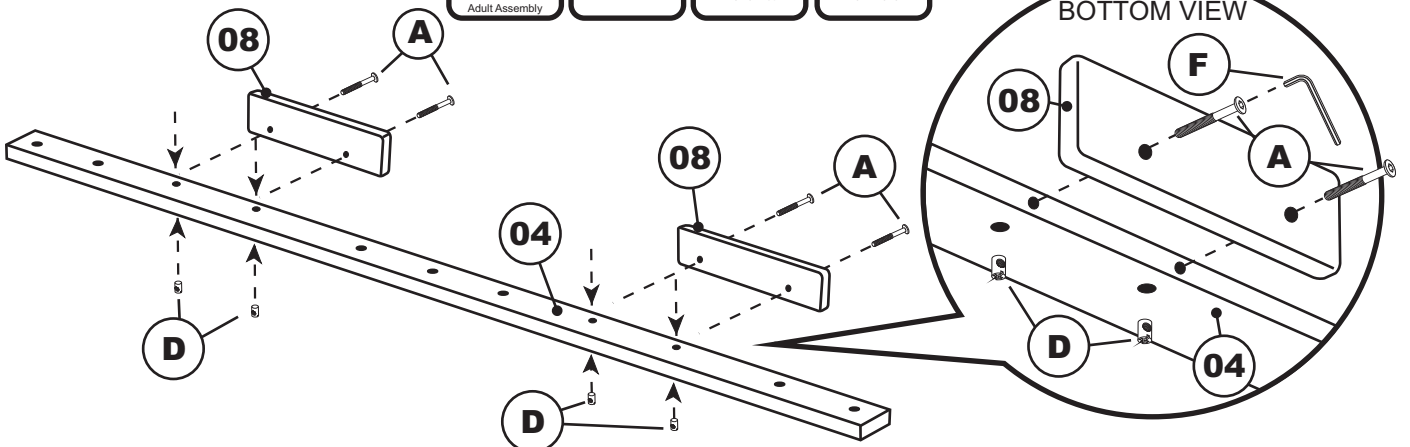
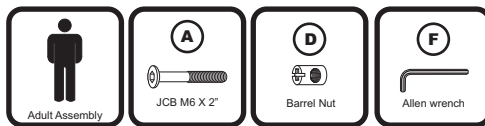

Attach the back boards (08) to the back rail (04), using JCB M6 X 2"(A), and barrel nut (D). Tighten with the Allen wrench (F).

STEP 2

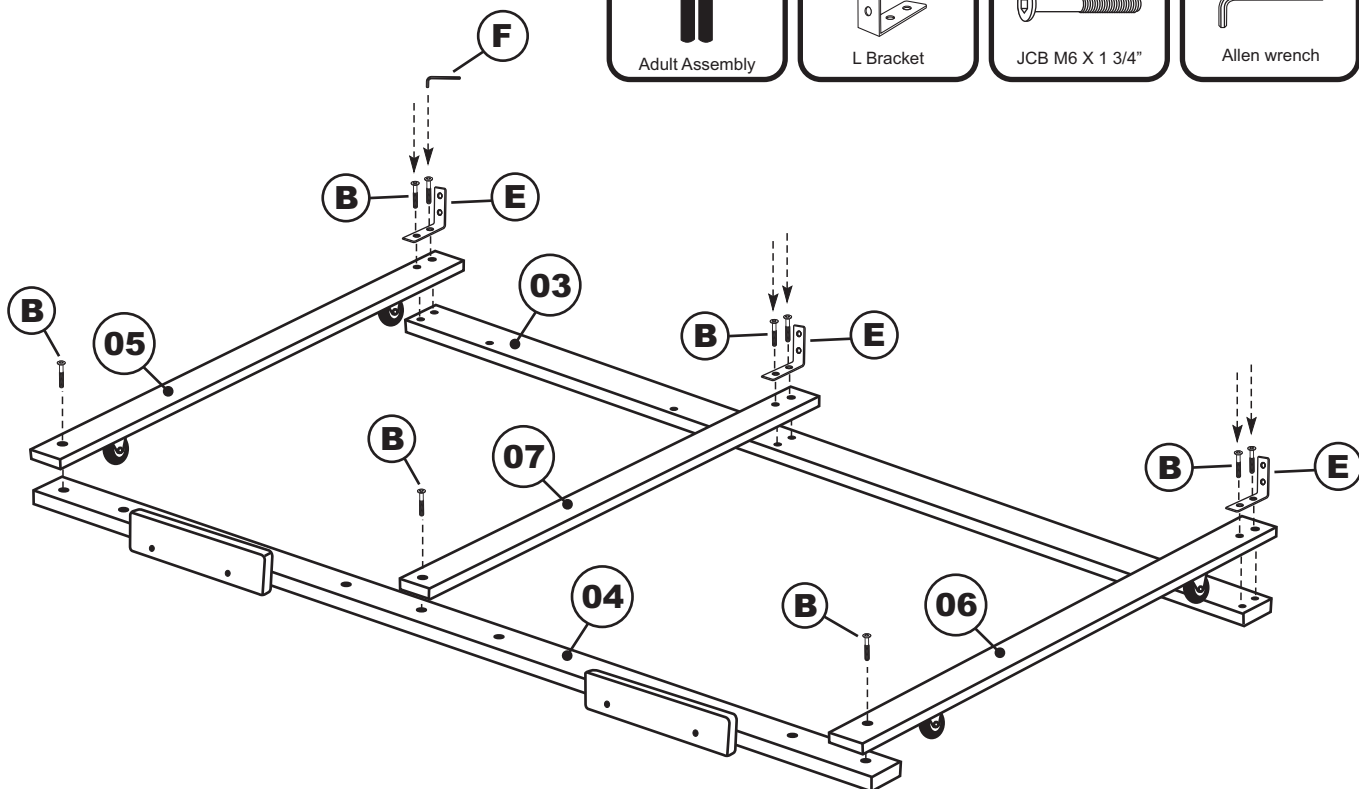
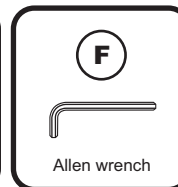
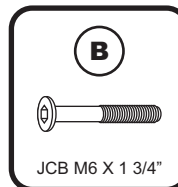
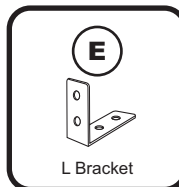

Attach the side/center cross rails (05,06+07) to the front rail (03) and back rail (04), using L bracket (E) and JCB M6 X 1 3/4" (B) as shown. Tighten with the Allen wrench (F).

STEP 3

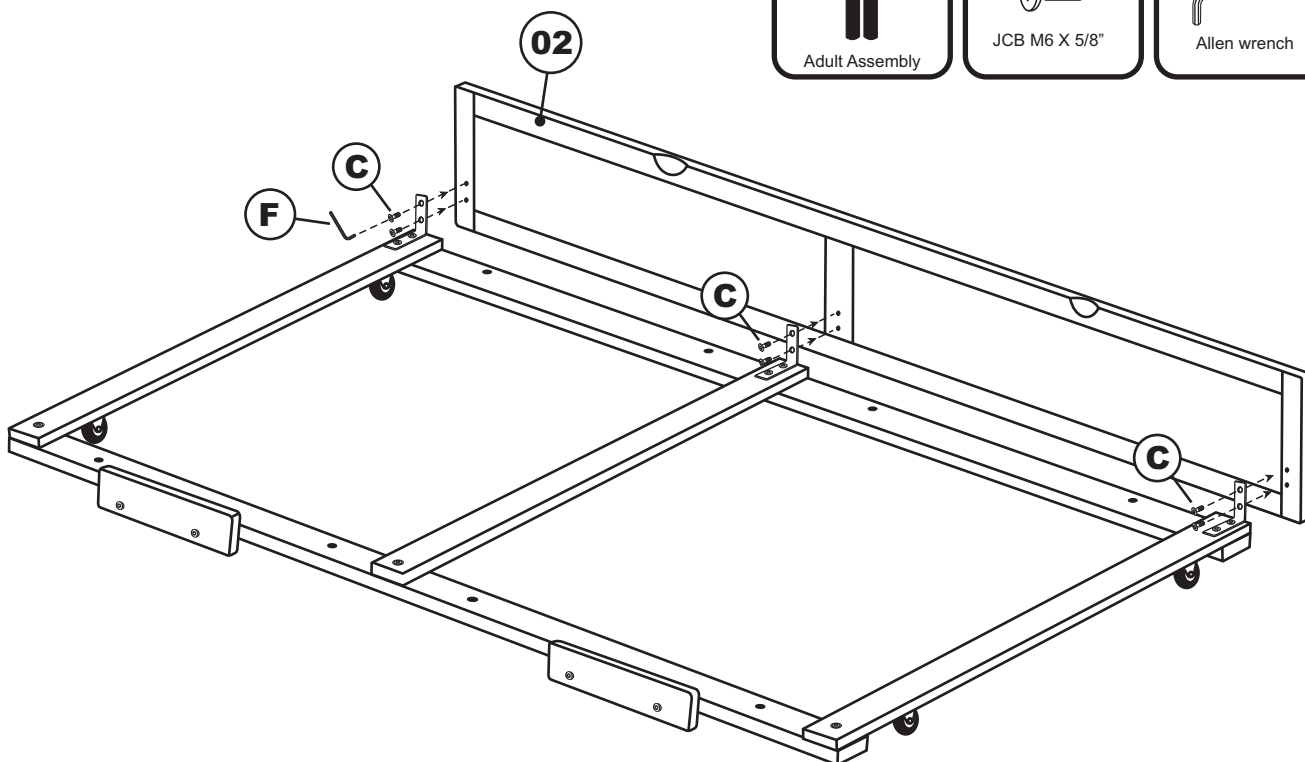
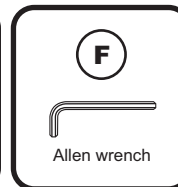
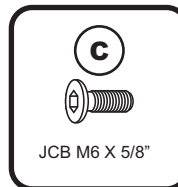

Attach the front panel (02) to assembled front rail as shown, using JCB M6 X 5/8" (C). Tighten with the Allen wrench (F).

STEP 4

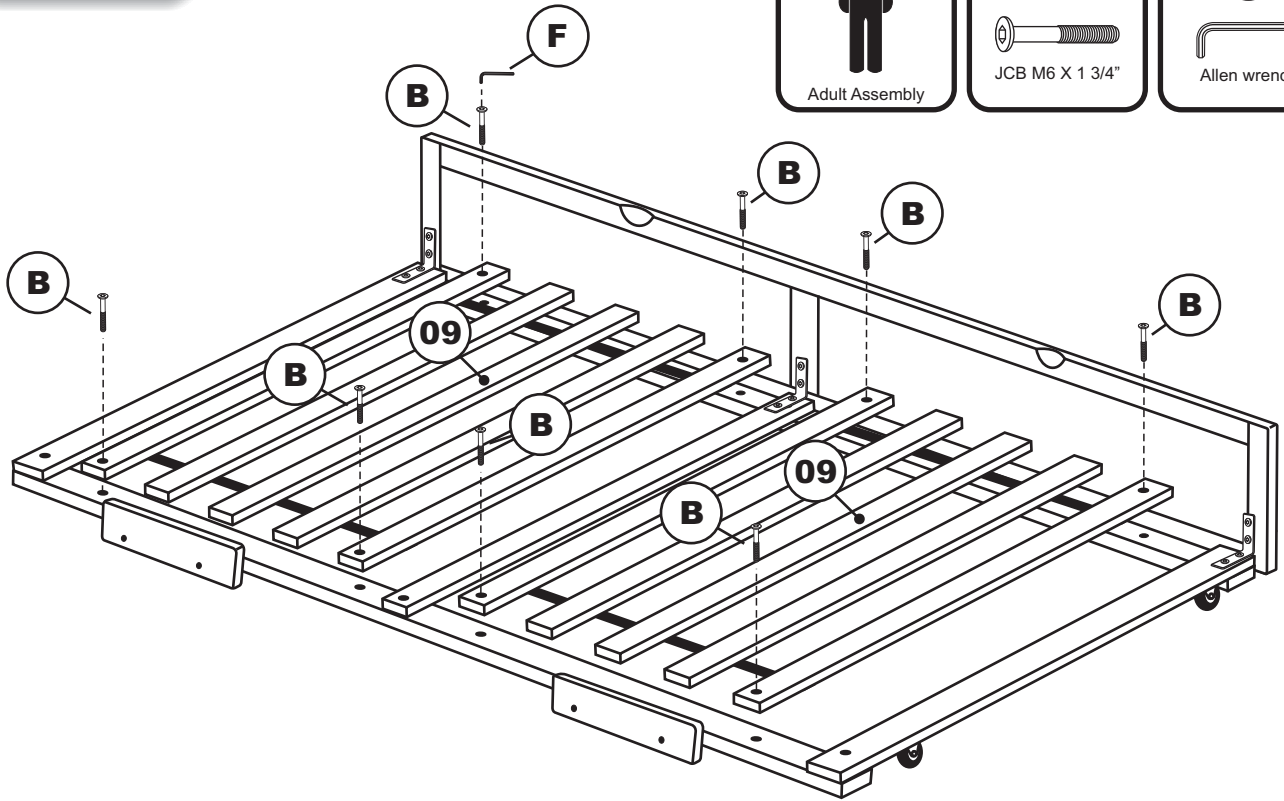
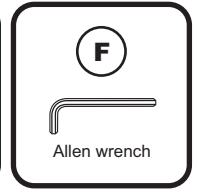
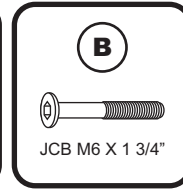

Lay the slats (09) onto the bed, and fix in place. Using JCB M6 X 1 3/4"(B), tighten with the Allen wrench (F)

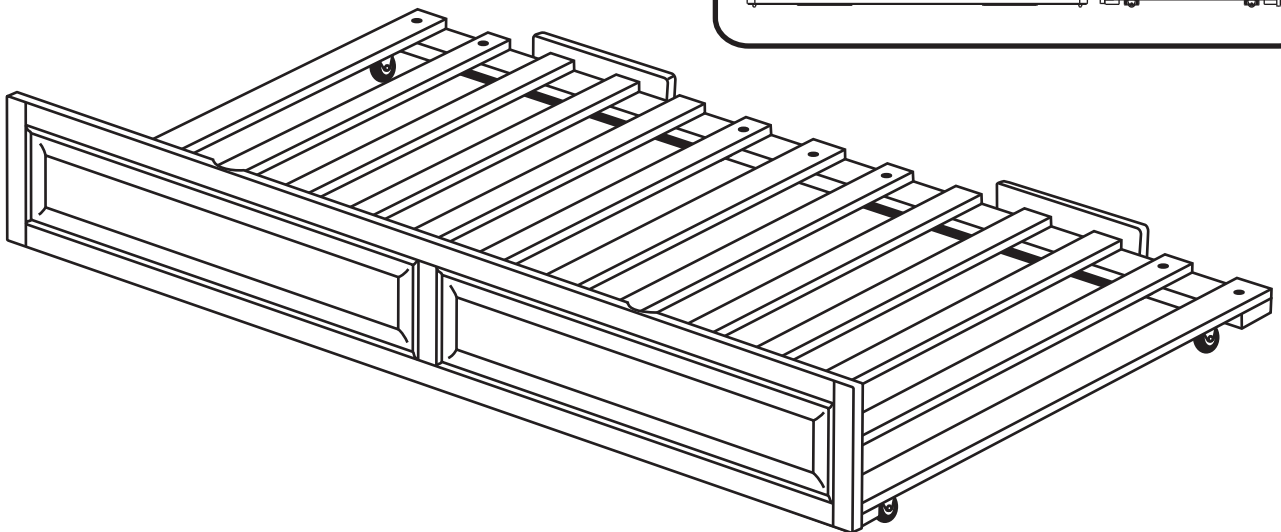
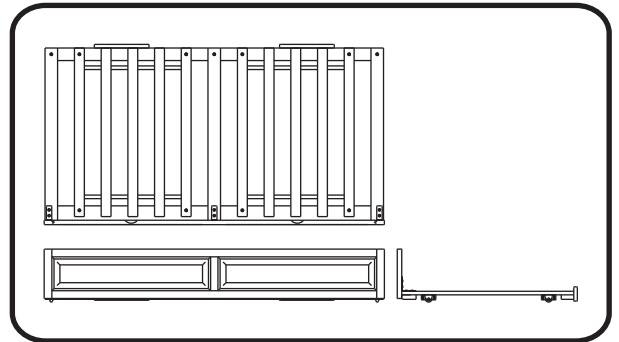

Congratulations !

Your Raised Panel Trundle is now ready for use.
We recommend that you periodically check that all screws are tight
and all parts are secure to ensure lasting safety.