

FIGURE

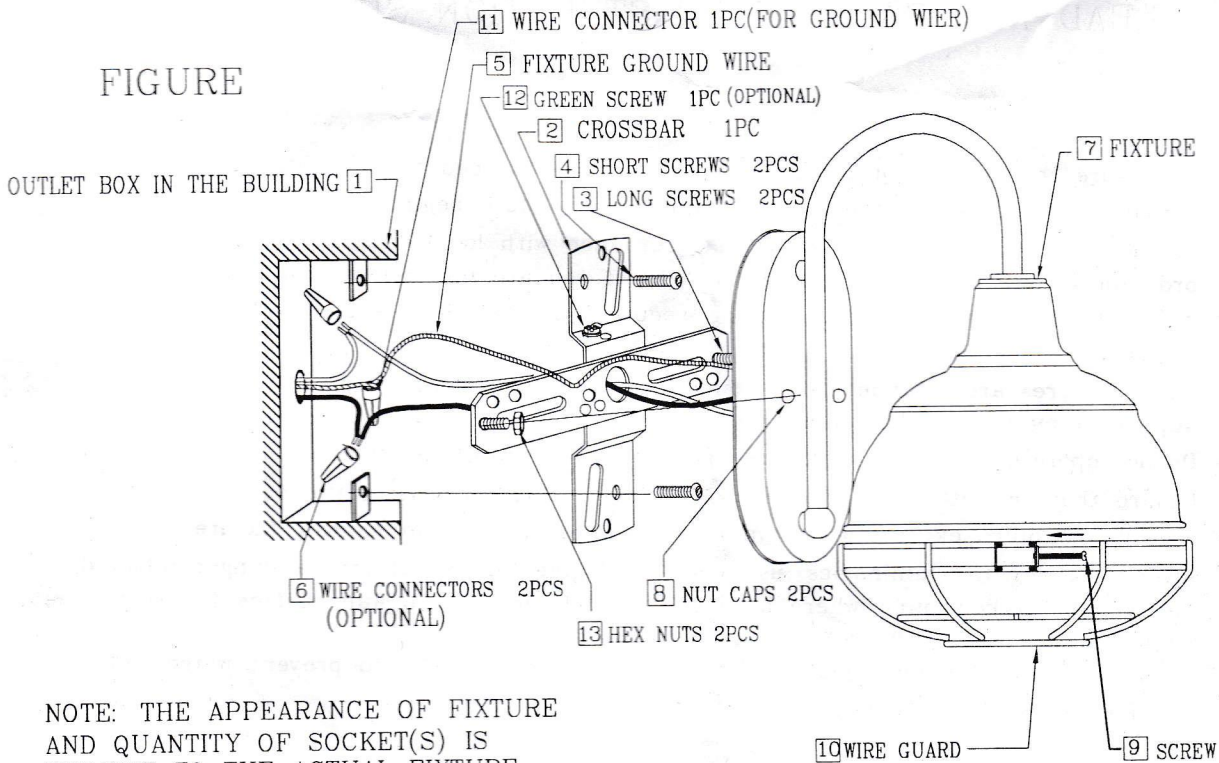

NOTE: THE APPEARANCE OF FIXTURE AND QUANTITY OF SOCKET(S) IS SUBJECT TO THE ACTUAL FIXTURE YOU RECEIVED, WHICH IS DIFFERENT FROM THE FIGURE IN THIS INSTRUCTION SHEET, BUT IN SAME INSTALLING WAY AS BELOW.

(3) INSTALLING WAY

- 1 OUTLET BOX IN THE BUILDING
- 2 CROSSBAR 1PC
- 3 LONG SCREWS 2PCS: PLACE THE SUPPLIED (3 LONG SCREWS) THROUGH THE HOLES IN (2 CROSSBAR). ADJUST TO THE DESIRED LENGTH AND SECURE TIGHTLY WITH (13 HEX NUTS). THIS WILL PREVENT (3 LONG SCREWS) FROM ROTATING WHEN (8 NUT CAPS) ARE ATTACHED.
- 4 SHORT SCREWS 2PCS : SECURE (2 CROSSBAR) TO (1 OUTLET BOX) WITH THE SUPPLIED (4 SHORT SCREWS).
- 5 FIXTURE GROUND WIRE: TWIST (5 FIXTURE GROUND WIRE) AND GROUND WIRE FROM OUTLET BOX, FIX THEM WITH (11 WIRE CONNECTOR) (PROVIDED).
- 6 WIRE CONNECTORS 2PCS(OPTIONAL): CONNECT FIXTURE WIRES WITH SUPPLY WIRES TOGETHER.
- 7 FIXTURE
- 8 NUT CAPS 2PCS: PUT (3 LONG SCREWS) THROUGH 2 HOLES ON (7 FIXTURE), SECURE (7 FIXTURE) AGAINST THE WALL WITH (8 NUT CAPS).
- 9 TURN ON ELECTRICITY AFTER ASSEMBLING THE BULBS TO TEST IF THE ELECTRICITY CAN WORK NORMALLY. (MAKE SURE THE BULBS CAN WORK)
- 10 WIRE GUARD: DRAW APART THE CUT OF (10) WIRE GUARD AT OPPOSITE DIRECTION BY HAND SO AS TO MAKE IT LARGE ENOUGH TO LET SHADE ON (7) FIXTURE SNAP IN, THEN FIX (10) WIRE GUARD WITH (9) SCREW SO THAT IT CAN NOT ROTATE.

# READ AND SAVE THIS INSTRUCTION SHEET

## ATTENTION

- (1) 1.1 To ensure the success of the installation, be sure to read these instructions and review the diagrams thoroughly before beginning.
- 1.2 All electrical connections must be in accordance with local codes, ordinances, or the National Electrical Code. If you are unfamiliar with the methods of installing electrical wiring, secure the services of a qualified licensed electrician.
- 1.3 These fixtures are intended to be building mounted and must be supported by the building structure.
- 1.4 Do not operate the lighting fixture close to any combustible material.
- 1.5 Ensure that the fitting is cool and switched off before changing the bulb.
- 1.6 Do not use bulbs exceeding maximum wattage as marked on lighting fixture.
- 1.7 After installing the luminaries, use waterproof glue (ex. GE-108) for caulking compound.
- 1.7.1 Caulk completely around where back of backplate meets the wall surface to prevent water from seeping into outlet box.
- 1.7.2 Caulk completely around gap between the parts of enclosure to prevent water from seeping into the enclosure.

## (2) CAUTION BEFORE INSTALLATION

- 2.1 Prepare tools and materials required, e.g.: Ladder, Wrench, Wire cutter, Screw driver, Bulbs and Wiring supplies as required by electrical code.
- 2.2 Before starting the installation, disconnect the power by opening the circuit breaker or by removing the fuse at the fuse box. Turning the power off using the light switch is not sufficient to prevent electrical shock.
- 2.3 If you are replacing an existing fixture, disconnect and remove the old fixture. Expose the supply wiring.
- 2.4 No rough or sharp edges are in contact with any of the wire, to ensure the insulation on any of the wires has not been damaged during installation.
- 2.5 The bare or green insulated wire are for grounding, do not connect with current carrying wires.
- 2.6 Firstly connect white (or rough) fixture wire with white supply wire and then connect black (or smooth) fixture wire with black supply wire. After fixture wires are connected with supplier wires, the bare parts of wires need to be completely covered by connector, to prevent from causing short circuit and electric leakage.

The method of wiring and operation refer to circuit diagram 1 and circuit diagram 2:

Circuit diagram 1

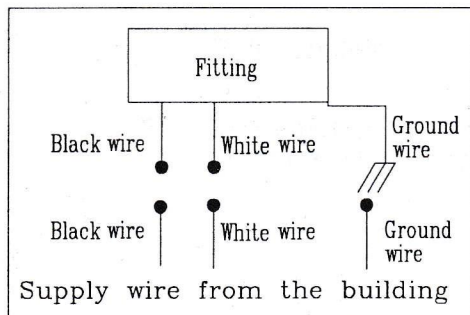

Circuit diagram 2

