

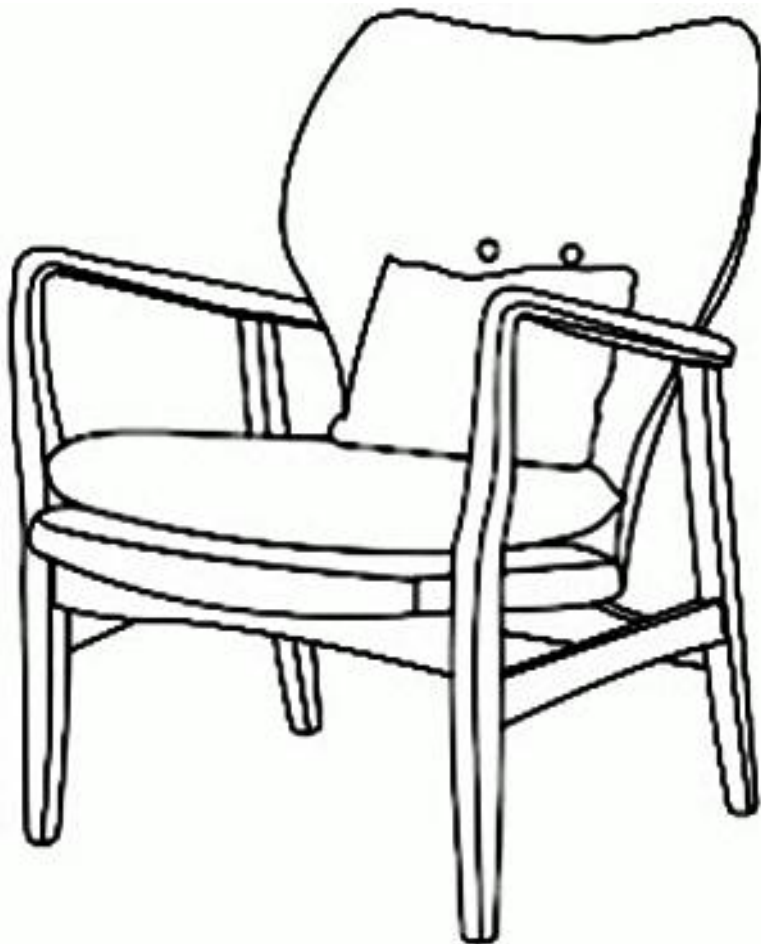



Assembly Instructions

Caution : You must read this before you proceed



Arm Chair

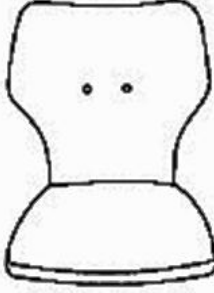

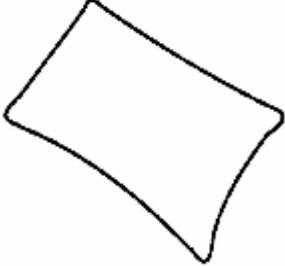
Parts List

Label	Picture	Description	QTY
A		Frame	1
B		Seat	1
C		Cushion	1
D		Pillow	1

Hardware

Label	Picture	Description	QTY
①		Screw (M4*40mm)	7
②		Screwdriver	1

Assembly Preparation

Before Beginning Assembly:

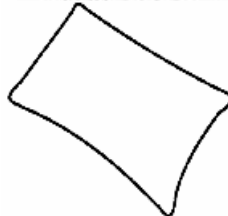
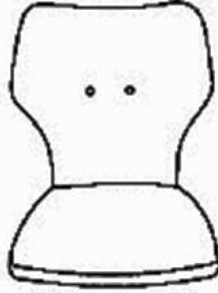

- Read instructions, cover to cover-



- Have 2 adults on hand for assembly-



- Do not assemble on flooring or carpet-



- Assemble on a clean non-marring surface (packing foam)-



- Save all packaging until finished-

Assembly Steps

Overview

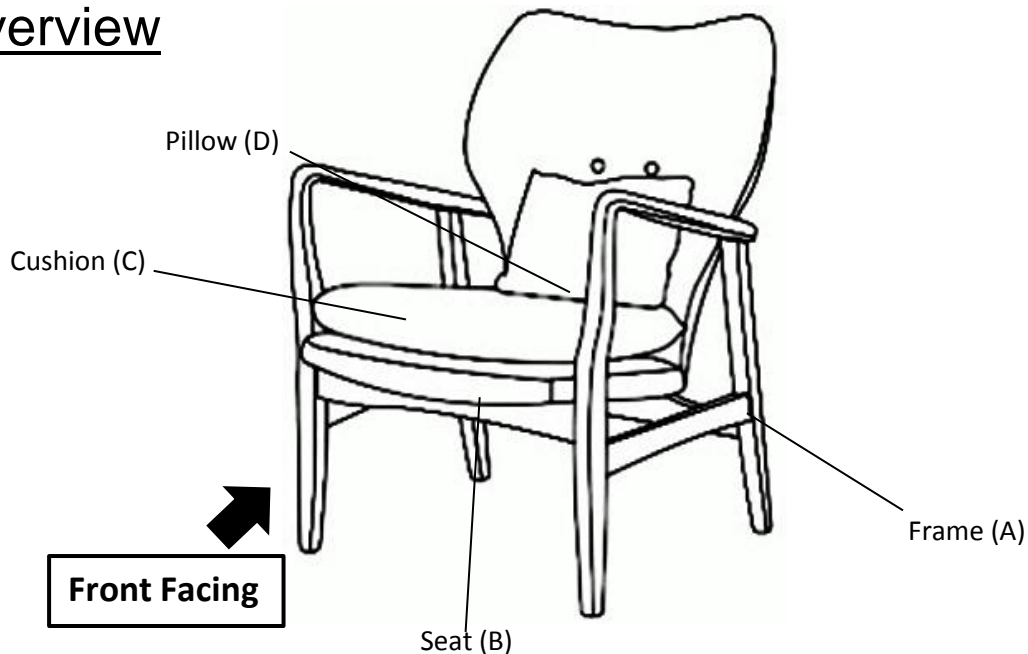

This Arm Chair has multiple parts and may require up to some 30 minutes to assemble. To give you an overview of the Arm Chair parts, the above picture is to help you put the various parts into perspective. Please read through the instructions below to familiarise yourself with the parts and steps before assembly.

Step 1



Frame (A)

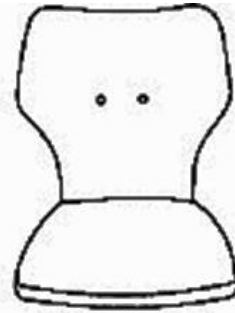

Seat (B)

Place the Frame(A) and Seat(B) on a clean, non-marring surface. Place the Frame(A) with the Legs facing skywards.

Step 2

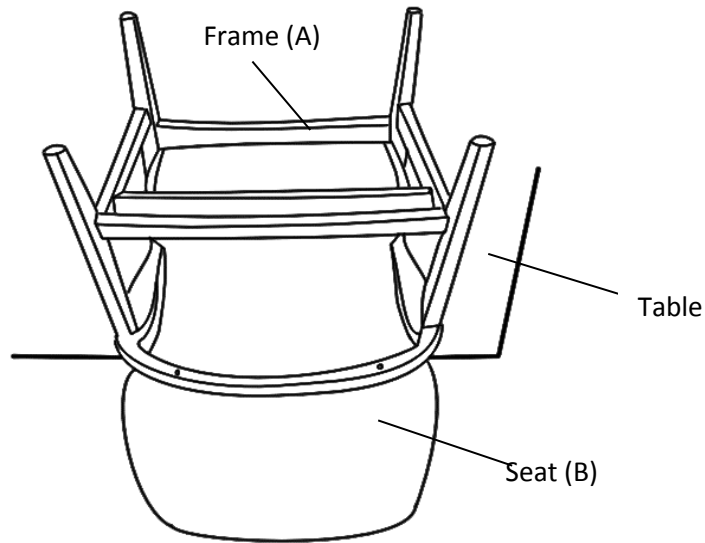

Seat(B) stuck in the middle of the Frame(A)

Step 2. 1

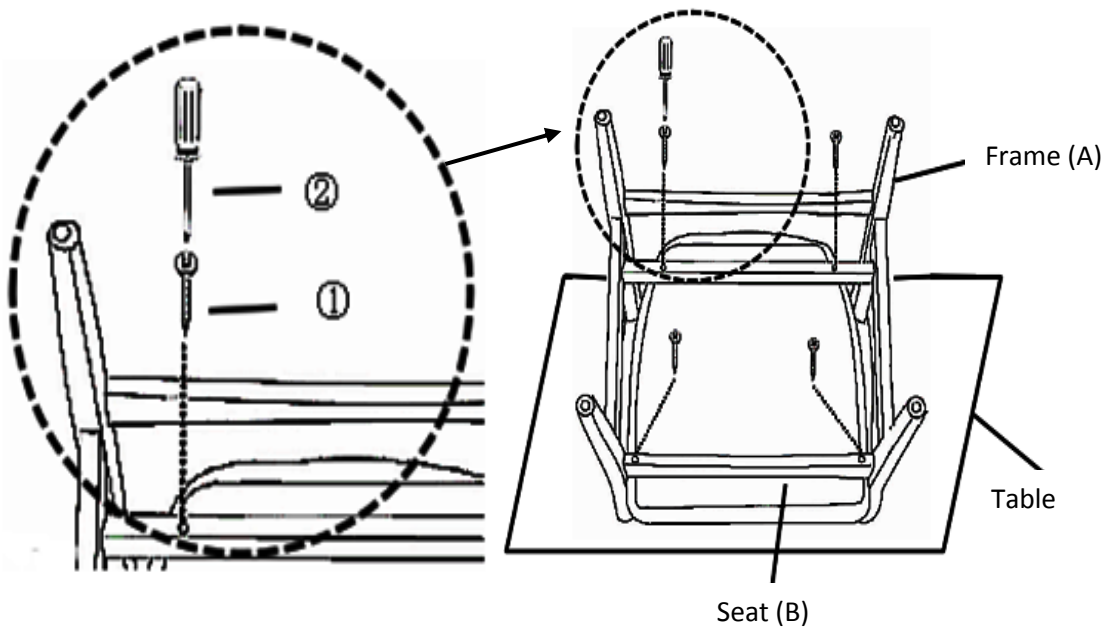

Step 2. 2

Place the Seat(B) on the side of a table, with the backrest facing down and perpendicular to the desktop.

Step 2.1: Place the Frame(A) onto the Seat(B) with the Seat(B) stuck in the middle of the Frame(A) as seen in picture. Make sure the same space between the both sides of the seat(B) backrest towards the frame(A) crosspieces.

Step 2.2: Attach Frame(A) to Seat(B) using Screws(①) with Screwdriver(②).

Friendly notice: If there exist gaps between the Frame(A) and Seat(B) which hinders the Installation , then pull the Seat(B) upwards into the Frame(A), this action helps to ensure there are no gaps between them, and then repeat the Step 2.2.

Do not fully tighten the Screws.

Step 3

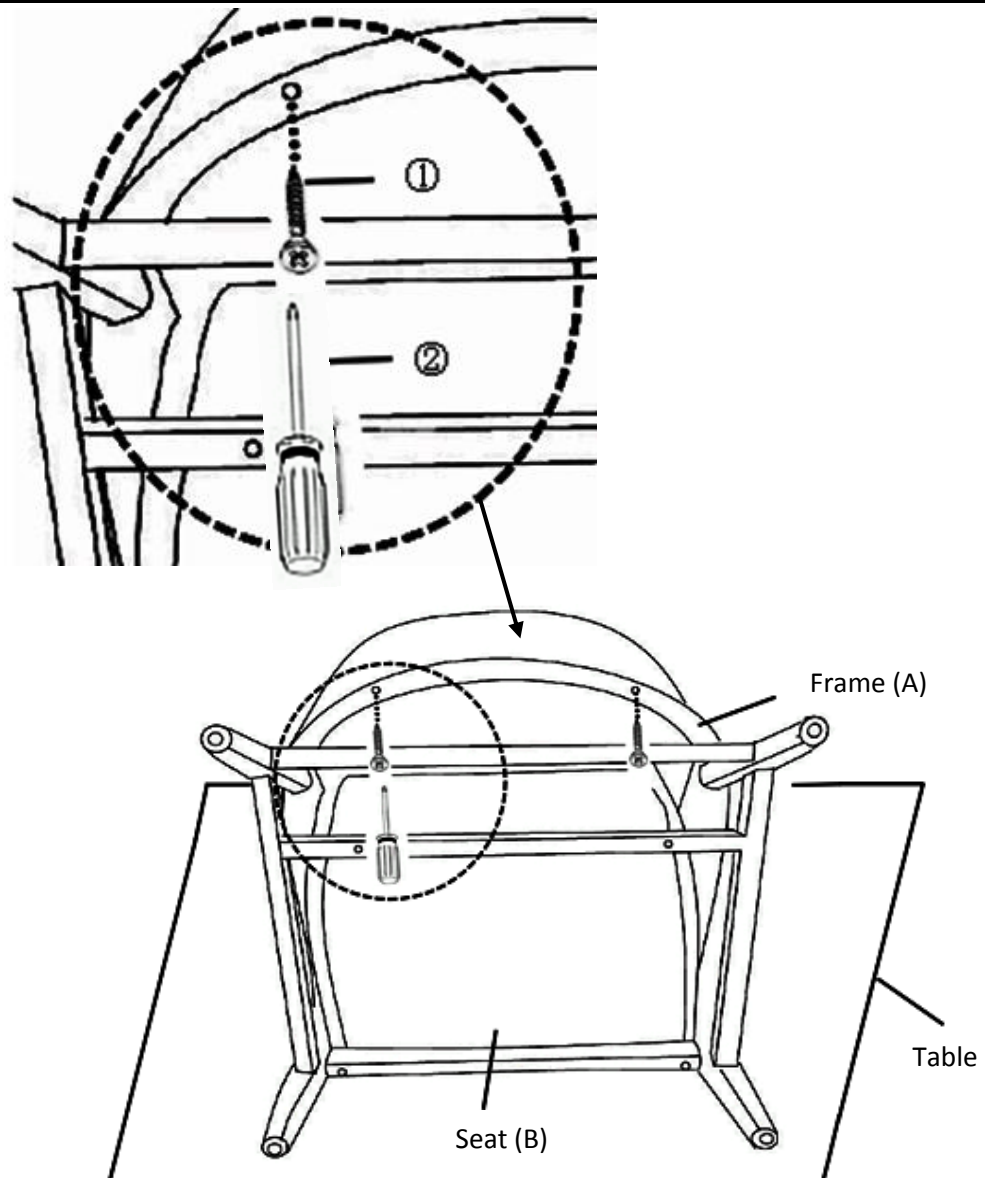

Next, install the Screws(①) on the back in a sequential manner by using Screwdriver (②).

Note: Do not overtighten the screws. Overtightening could lead to damage to the product.

TIGHTEN ONLY UNTIL GET SECURE AND STABLE.

Step 4

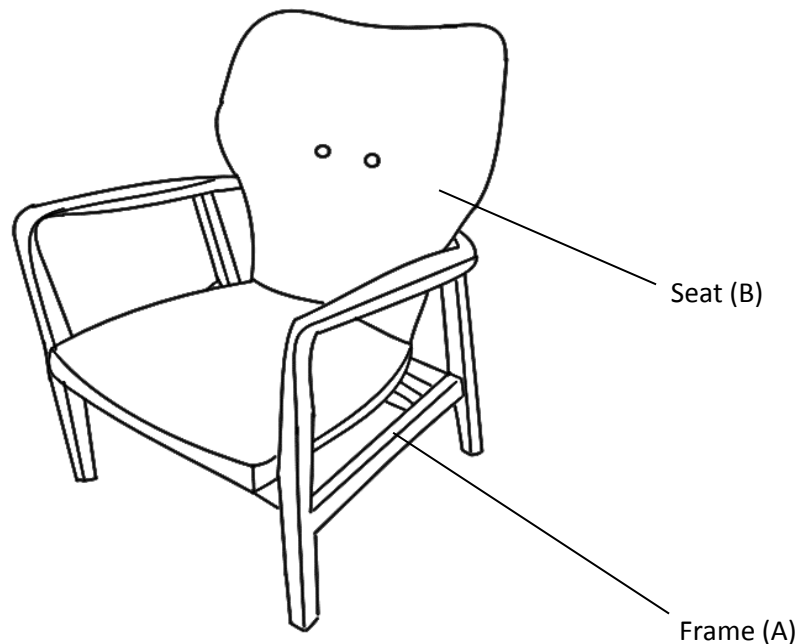

Test for Stability

Finally, stand the Arm Chair right side up, and place the Arm Chair on a **LEVEL SURFACE**.

Inspect it and make sure all parts are adequately connected.

Gently and gracefully, sit into to the Arm Chair.

This would help to align all the parts at all the joint areas.

Then get off the Arm Chair, and place it facedown.

Proceed to tighten all Screws in a sequential manner.

If there is still wobbles, loosen the screws and execute this same process.



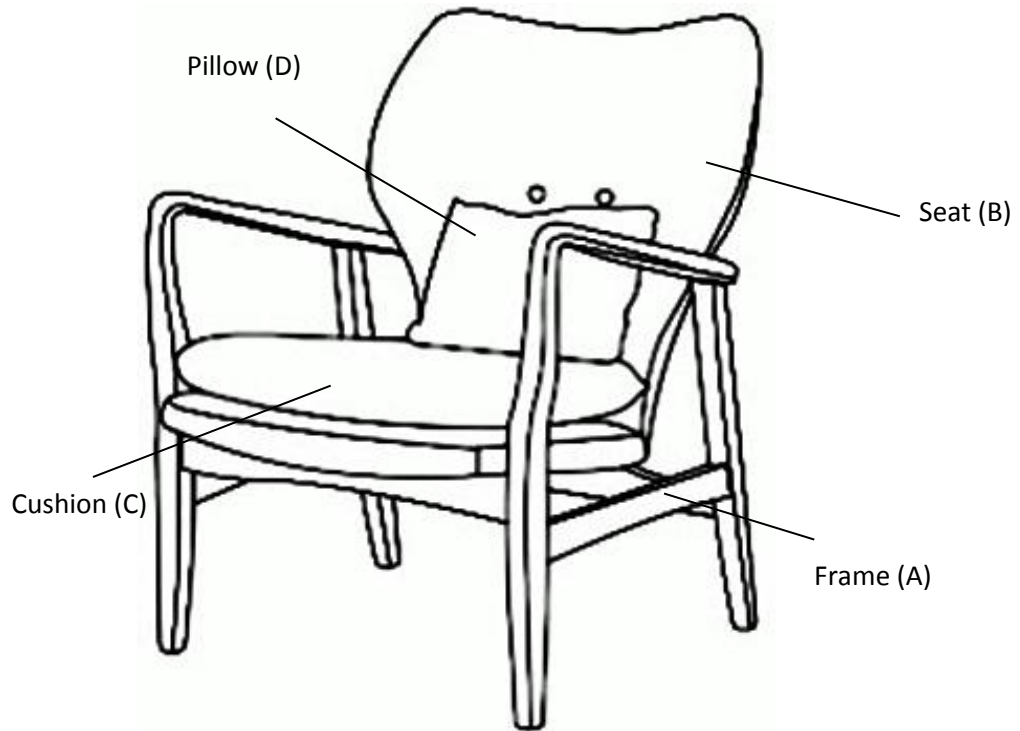







Step 5



Position the Arm Chair right side up. Make sure all parts are connected and securely locked into position.
Put the Cushion(C) and Pillow(D) on the seat(B) as shown in the picture.
Your Arm Chair is ready for use.

This Arm Chair can only be used on a flat, level surface.

Care & Maintenance

-  ● Do not put hot items directly on furniture surface
 -  ● Do not clean furniture with harsh cleansers or polish.
 -  ● Do not place furniture under direct sunlight.
 -  ● Do not place furniture near heating or cooling vents.
 -  ● Do not write on furniture without a padded barrier to protect the surface.
 -  ● Do not place furniture outside . For indoor use only .
 -  ● Not for commercial use. For residential use only .
 -  ● Stains may be removed with mild soap solution and damp cloth.
 -  ● Children should not climb or jump on the furniture.
-
-  ● Dust and pick-up spills using a clean, non-colored, lint-free cloth .