



[DE]

Warnung: Lesen Sie diese Anleitung vor dem Zusammenbau bitte vollständig durch. Überprüfen Sie, ob Sie alle auf den Seiten aufgeführten Komponenten und Werkzeuge haben. Bewahren Sie die Anleitung zum späteren Nachschlagen auf. Teile des Zusammenbaus lassen sich mit 2 Personen leichter durchführen. Suchen Sie bei Bedarf professionelle Hilfe.

Warnung: Legen Sie alle Teile auf eine ebene Fläche. Legen Sie eine weiche Decke oder Ähnliches darunter, um sie vor Kratzern oder Flecken zu schützen. Vermeiden Sie es, Komponenten über den Boden zu ziehen oder zu schieben.

Warnung: Überprüfen Sie regelmäßig alle Beschläge und Befestigungen, um sicherzustellen, dass sie sicher sind und um Unfälle zu vermeiden. Wenn Teile fehlen, kaputt, beschädigt oder abgenutzt sind, verwenden Sie das Produkt nicht weiter, bis Reparaturen mit vom Hersteller autorisierten Teilen durchgeführt wurden.

Warnung: Stellen Sie Möbel nicht in die Nähe von Feuerquellen oder Gegenständen mit hohen Temperaturen, um Brandgefahr zu vermeiden. Stellen Sie Möbel nicht in feuchte Umgebungen, um Materialschäden zu vermeiden.

Warnung: Reinigen Sie Möbel mit einem feuchten Tuch oder Alkohol, vermeiden Sie die Verwendung von Reinigungsmitteln mit ätzenden Chemikalien.

Warnung: Lassen Sie Kinder nicht auf die Möbel klettern, da dies zum Umkippen und zu schweren Verletzungen führen kann. Bauen Sie die Möbel außerhalb der Reichweite von Kindern zusammen.

Warnung: Schwamm und Tuch können während des Transports gequetscht und verformt werden. Machen Sie sich keine Sorgen.

Nachdem Sie sie aus der Tasche genommen haben, können Sie den Schwamm leicht abtupfen, um die Wiederherstellung der Elastizität zu beschleunigen, oder ihn einige Tage liegen lassen, damit er seine ursprüngliche Elastizität wiedererlangt.

Warnung: Stoffe können in direktem Sonnenlicht verblassen oder ihre Farbe ändern. Minimieren Sie direkte Sonneneinstrahlung, um die Lebensdauer Ihrer Möbel zu verlängern.



[EN]

Warning: Please read these instructions fully before starting assembly. Check you have all the components and tools listed on pages. Keep the instructions for later reference. Parts of the assembly will be easier with 2 people. Seek professional assistance if necessary.

Warning: Please place all parts on a flat surface. Place a soft blanket or similar underneath to protect against scratches or stains. Avoid dragging or sliding components across the floor.

Warning: Regularly check all fittings and fastenings to ensure they are secure and to prevent accidents. If any parts are missing, broken, damaged, or worn, discontinue use of the product until repairs have been made using factory authorized parts.

Warning: Do not place furniture close to fire sources or high-temperature objects to avoid the risk of fire. Do not place furniture in damp environments to prevent material damage.

Warning: Clean furniture with a damp cloth or alcohol, avoid using cleaning agents containing corrosive chemicals.

Warning: Do not allow children to climb on the furniture as this may result in tipping and serious personal injury. Assemble the furniture away from the reach of children.

Warning: The sponge and cloth may be squeezed and deformed during transportation, please don't worry, after you take it out of the bag, you can gently pat the sponge to speed up the recovery of elasticity, or leave it for a few days, it can recover to its original elasticity.

Warning: Fabrics can fade or change color in direct sunlight. Minimize direct sunlight exposure to extend the life of your furniture.



[FR]

Attention : Veuillez lire attentivement ces instructions avant de commencer l'assemblage. Vérifiez que vous disposez de tous les composants et outils répertoriés sur les pages. Conservez les instructions pour référence ultérieure. Certaines parties de l'assemblage seront plus faciles à 2 personnes. Demandez l'aide d'un professionnel si nécessaire.

Attention : Veuillez placer toutes les pièces sur une surface plane. Placez une couverture douce ou similaire en dessous pour les protéger des rayures ou des taches. Évitez de faire glisser les composants sur le sol.

Attention : Vérifiez régulièrement tous les accessoires et fixations pour vous assurer qu'ils sont bien fixés et pour éviter les accidents. Si des pièces manquent, sont cassées, endommagées ou usées, cessez d'utiliser le produit jusqu'à ce que les réparations aient été effectuées à l'aide de pièces agréées par l'usine.

Attention : Ne placez pas les meubles à proximité de sources de feu ou d'objets à haute température pour éviter tout risque d'incendie. Ne placez pas les meubles dans des environnements humides pour éviter tout dommage matériel.

Attention : Nettoyez les meubles avec un chiffon humide ou de l'alcool, évitez d'utiliser des produits de nettoyage contenant des produits chimiques corrosifs.

Attention : Ne laissez pas les enfants grimper sur les meubles car cela pourrait entraîner un basculement et des blessures graves. Assemblez les meubles hors de portée des enfants.

Attention : L'éponge et le chiffon peuvent être comprimés et déformés pendant le transport, ne vous inquiétez pas, après l'avoir sorti du sac, vous pouvez tapoter doucement l'éponge pour accélérer la récupération de l'élasticité, ou la laisser pendant quelques jours, elle peut retrouver son élasticité d'origine.

Attention : les tissus peuvent se décolorer ou changer de couleur en plein soleil. Réduisez l'exposition directe au soleil pour prolonger la durée de vie de vos meubles.



[IT]

Attenzione: leggere attentamente queste istruzioni prima di iniziare il montaggio. Verificare di avere tutti i componenti e gli strumenti elencati nelle pagine. Conservare le istruzioni per riferimento futuro. Alcune parti del montaggio saranno più facili con 2 persone. Se necessario, chiedere assistenza professionale.

Attenzione: posizionare tutte le parti su una superficie piana. Posizionare una coperta morbida o simile sotto per proteggere da graffi o macchie. Evitare di trascinare o far scivolare i componenti sul pavimento.

Attenzione: controllare regolarmente tutti i raccordi e i dispositivi di fissaggio per assicurarsi che siano sicuri e per prevenire incidenti. Se alcune parti sono mancanti, rotte, danneggiate o usurate, interrompere l'uso del prodotto fino a quando non siano state effettuate le riparazioni utilizzando parti autorizzate dalla fabbrica.

Attenzione: non posizionare i mobili vicino a fonti di fuoco o oggetti ad alta temperatura per evitare il rischio di incendio. Non posizionare i mobili in ambienti umidi per evitare danni materiali.

Attenzione: pulire i mobili con un panno umido o alcol, evitare di utilizzare detergenti contenenti sostanze chimiche corrosive.

Attenzione: non consentire ai bambini di arrampicarsi sui mobili poiché ciò potrebbe causare ribaltamenti e gravi lesioni personali.

Montare i mobili lontano dalla portata dei bambini.

Attenzione: la spugna e il panno potrebbero schiacciarsi e deformarsi durante il trasporto, non preoccuparti, dopo averli tolti dalla borsa, puoi picchiettare delicatamente la spugna per accelerare il recupero dell'elasticità, oppure lasciarla per qualche giorno, in modo che possa recuperare la sua elasticità originale.

Attenzione: i tessuti possono sbiadire o cambiare colore alla luce solare diretta. Riduci al minimo l'esposizione alla luce solare diretta per prolungare la durata dei tuoi mobili.



[ES]

Advertencia: Lea estas instrucciones completamente antes de comenzar el montaje. Compruebe que tiene todos los componentes y herramientas que se enumeran en las páginas. Conserve las instrucciones para consultarlas más adelante. El montaje de algunas partes será más sencillo con 2 personas. Busque ayuda profesional si es necesario.

Advertencia: Coloque todas las piezas sobre una superficie plana. Coloque una manta suave o algo similar debajo para protegerlas de rayones o manchas. Evite arrastrar o deslizar los componentes por el piso.

Advertencia: Revise regularmente todos los accesorios y fijaciones para asegurarse de que estén seguros y evitar accidentes. Si falta alguna pieza, está rota, dañada o desgastada, deje de usar el producto hasta que se hayan realizado las reparaciones con piezas autorizadas de fábrica.

Advertencia: No coloque los muebles cerca de fuentes de fuego u objetos a alta temperatura para evitar el riesgo de incendio. No coloque los muebles en ambientes húmedos para evitar daños materiales.

Advertencia: Limpie los muebles con un paño húmedo o alcohol, evite usar agentes de limpieza que contengan químicos corrosivos.





Advertencia: No permita que los niños se suban a los muebles ya que esto puede provocar que se vuelquen y lesiones personales graves. Monte los muebles fuera del alcance de los niños.

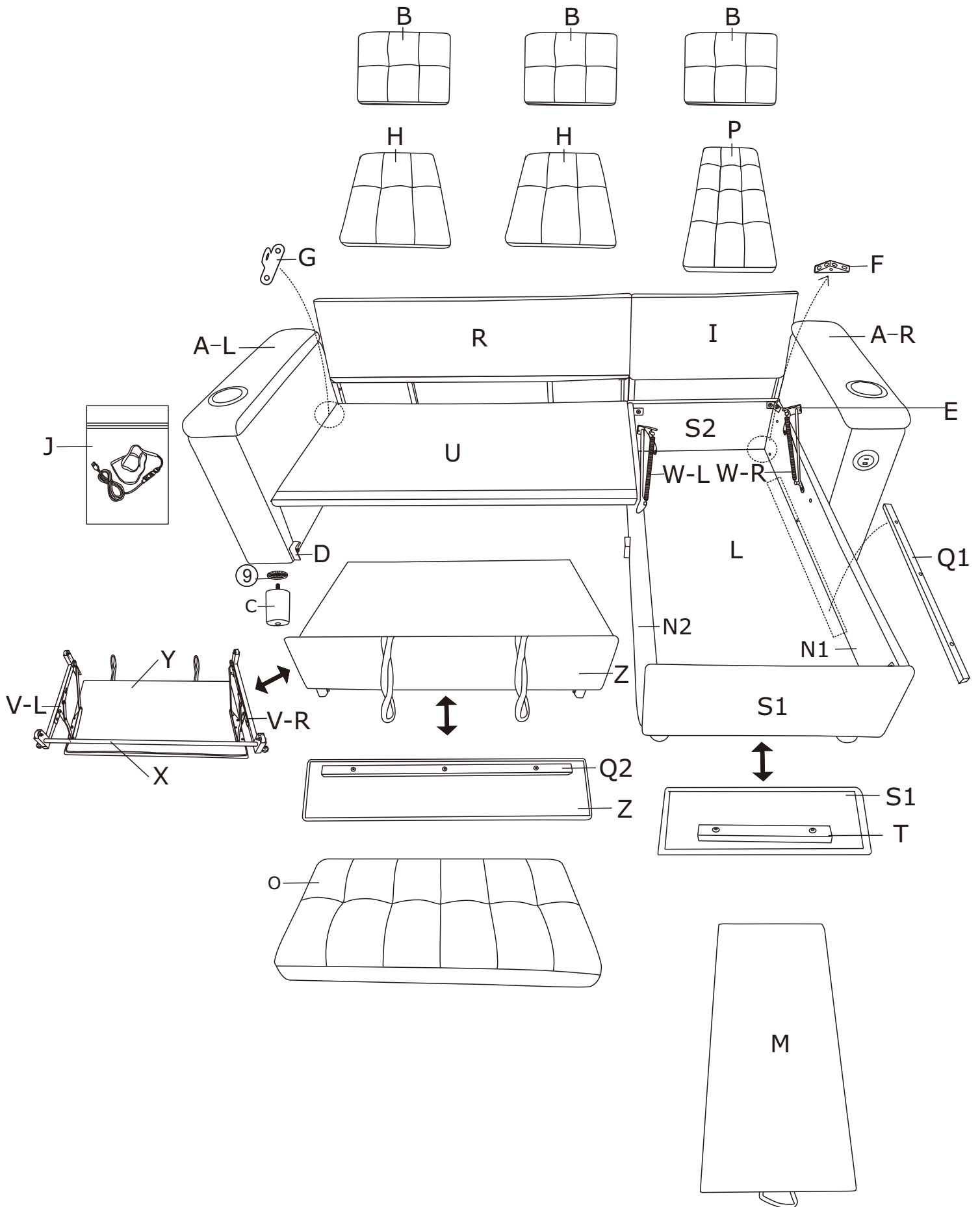

Advertencia: La esponja y el paño pueden apretarse y deformarse durante el transporte. No se preocupe, después de sacarlo de la bolsa, puede dar golpecitos suaves a la esponja para acelerar la recuperación de la elasticidad, o dejarlo unos días, puede recuperar su elasticidad original.

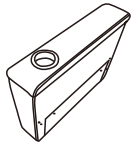
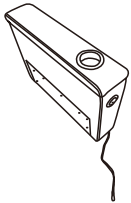
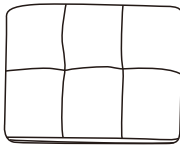
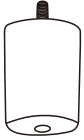
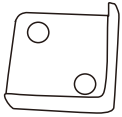
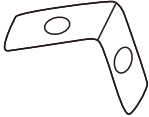

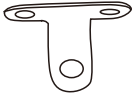
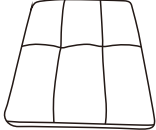
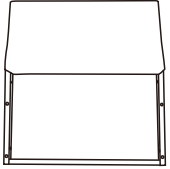



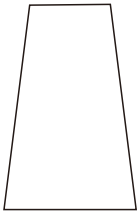
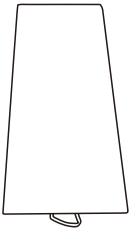

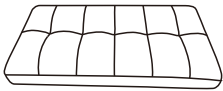
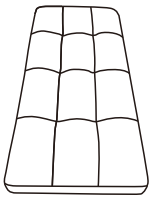
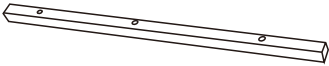
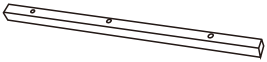
Advertencia: Las telas pueden desteñirse o cambiar de color con la luz solar directa. Minimice la exposición directa a la luz solar para prolongar la vida útil de sus muebles.

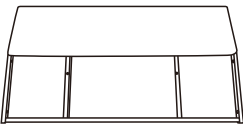
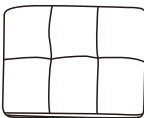

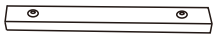

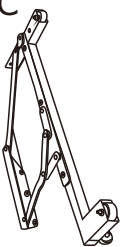
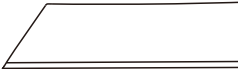
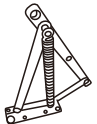
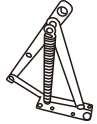



Parts List



<p>A-Lx1PC</p> 	<p>A-Rx1PC</p> 	<p>Bx2PCS</p> 	<p>Cx8PCS</p> 
<p>Dx2PS</p> 	<p>Ex4PCS</p> 	<p>Fx4PCS</p> 	<p>Gx4PCS</p> 
<p>Hx2PCS</p> 	<p>Ix1PC</p> 	<p>Jx2PCS</p>  <p>230CM</p>	<p>J1x1PC J2x1PC</p>  <p>J1x1PC J2x1PC</p>

<p>Lx1PC</p> 	<p>Mx1PC</p> 	<p>N1x1PC</p> 	<p>N2x1PC</p> 
<p>Ox1PC</p> 	<p>Px1PC</p> 	<p>Q1x2PCS</p> 	<p>Q2x1PC</p> 

Rx1PC 	Bx1PC 	S1x1PC 	S2x1PC 
Tx1PC 	V-Lx1PC 	V-Rx1PC 	Ux1PC 
W-Lx1PC 	W-Rx1PC 	Xx1PC 	Yx1PC 
Zx1PC 			

① X56PCS+1PC  M6X20mm	② X4PCS+1PC  M6X35mm	③ X25PCS+1PC  M6X45mm	④ X2PCS+1PC  M6X50mm	
⑤ X2PCS+1PC  M6	⑥ X33PCS+1PC  M6X18X1.2mm	⑦ X1PC  M6	⑧ X1PC 	⑨ X8PCS+1PC 

1

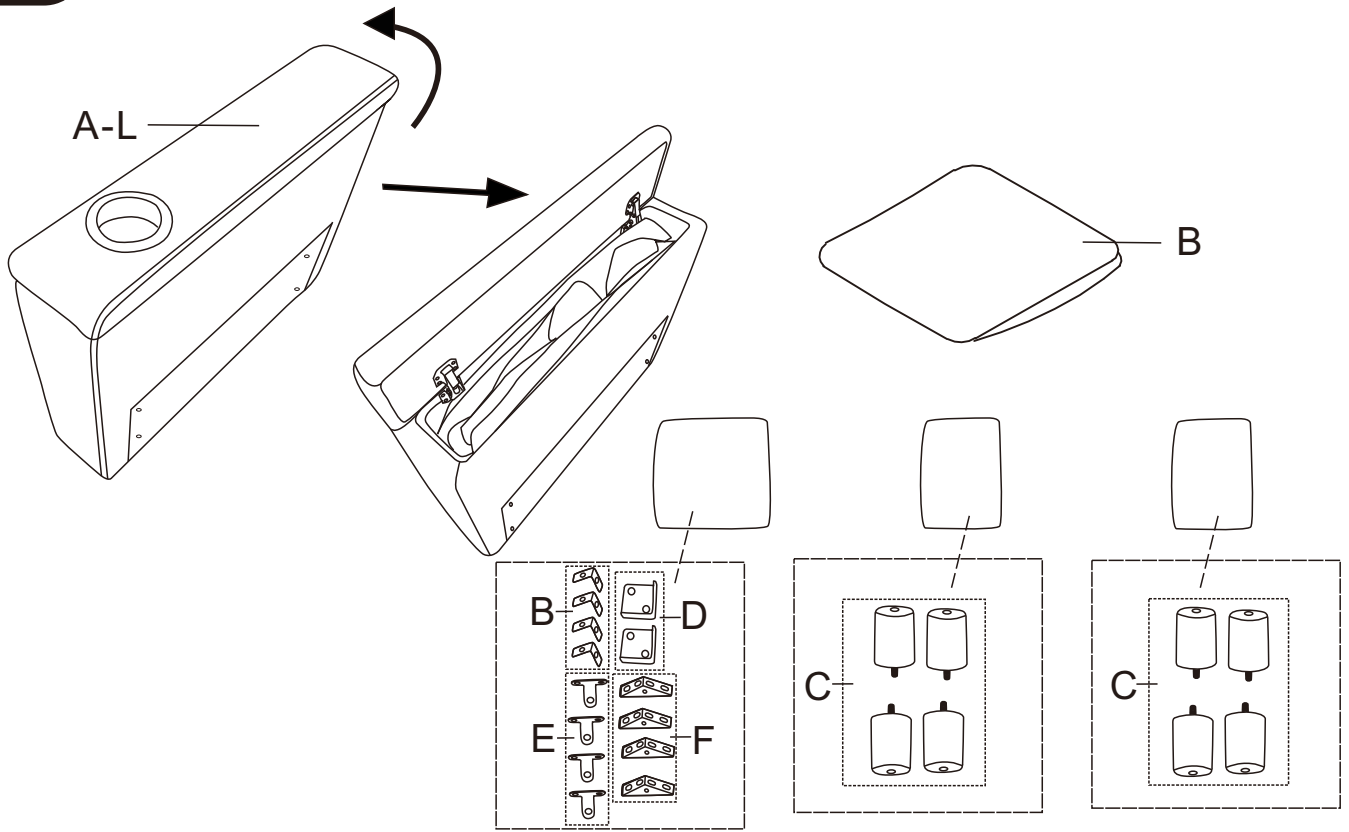

A-L		1PC
-----	--	-----

2

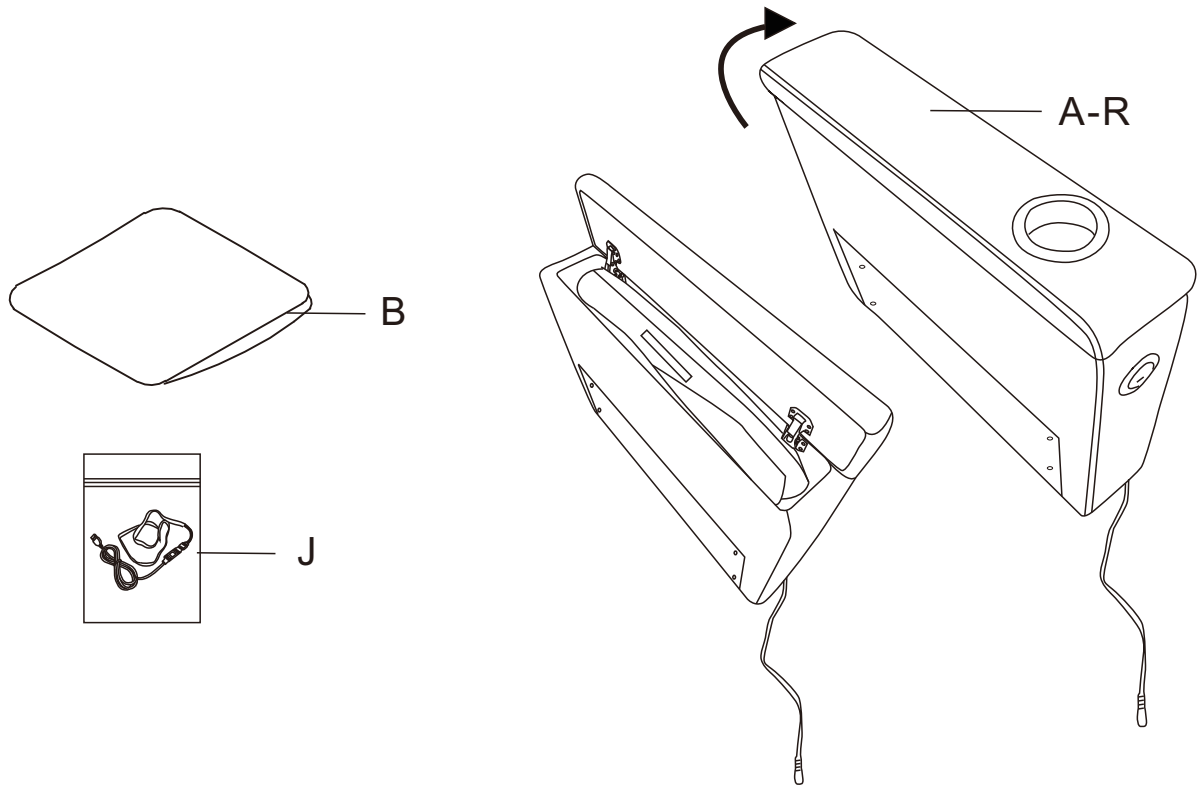

A-R		1PC
-----	--	-----

3

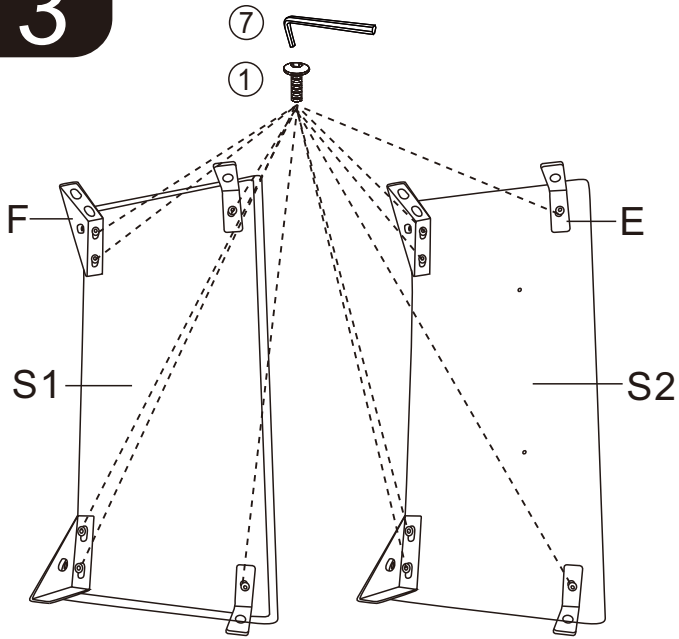

E		4PCS
F		4PCS
S1		1PC
S2		1PC
①	 M6x20mm	12PCS
⑦		1PC

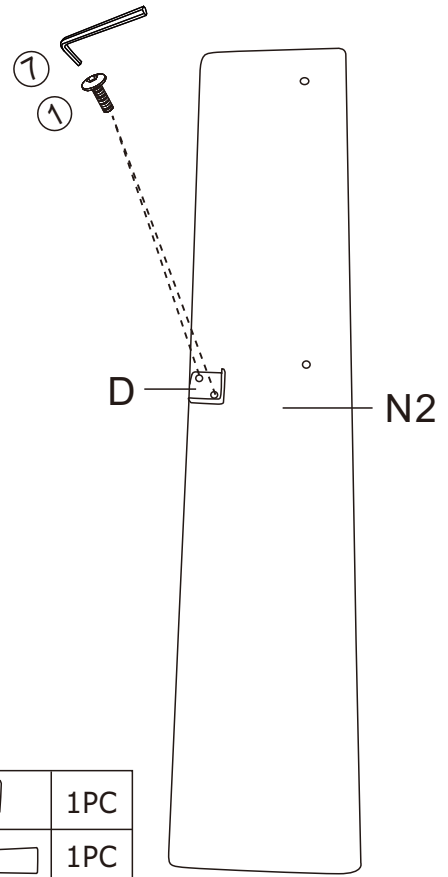

D		1PC
N2		1PC
①	 M6x20mm	2PCS
⑦		1PC

4

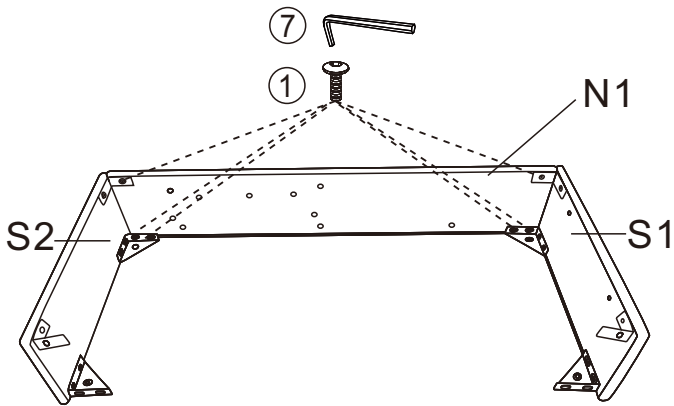



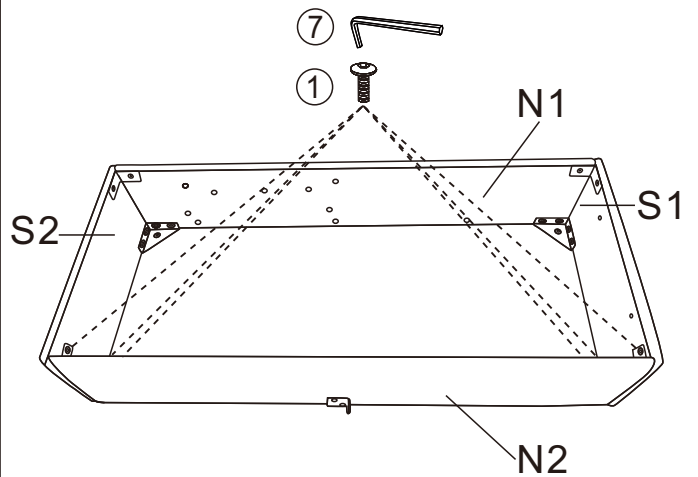

N1		1PC
①	 M6x20mm	6PCS
⑦		1PC

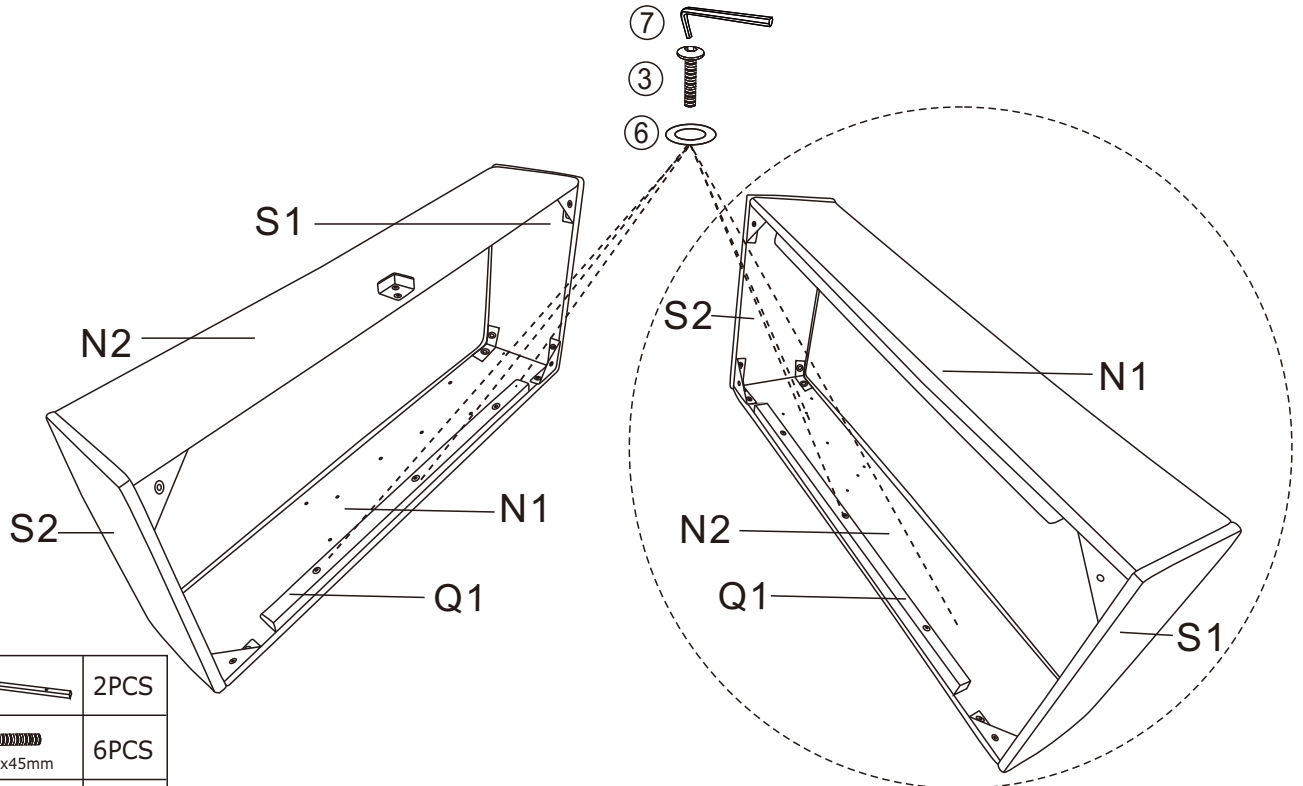

①	 M6x20mm	6PCS
⑦		1PC



5

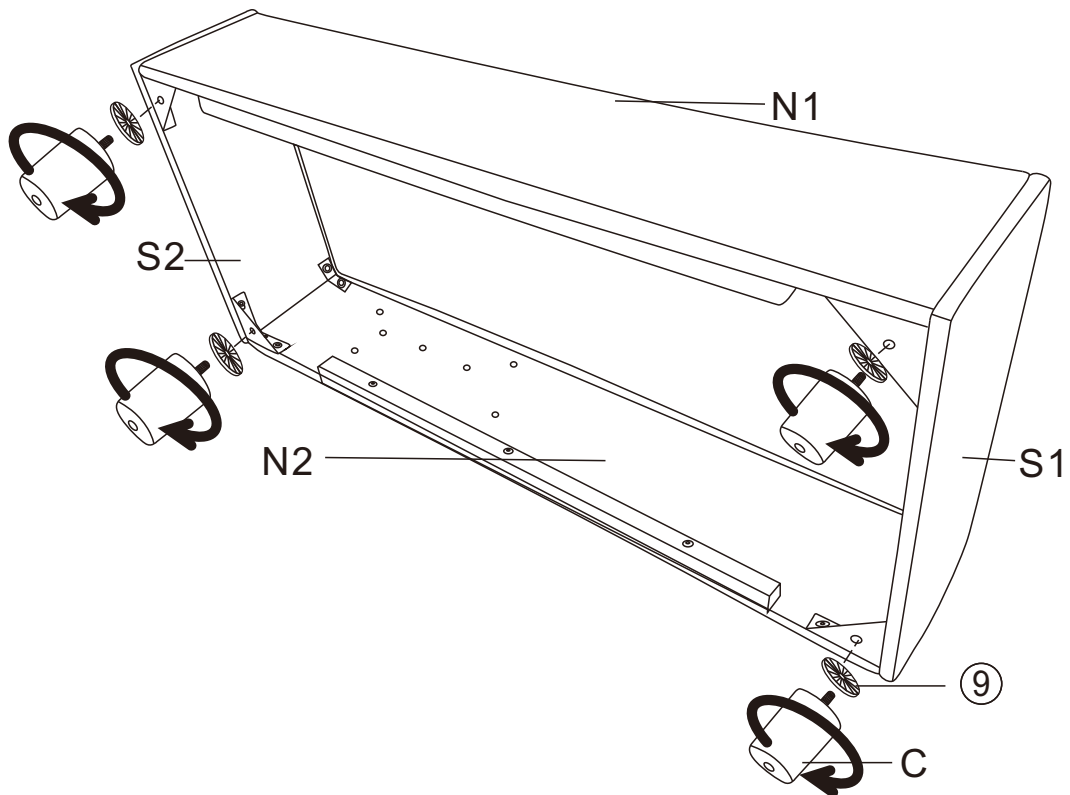

Q1		2PCS
③	 M6x45mm	6PCS
⑥		6PCS
⑦		1PC

6



C		4PCS
⑨		4PCS

7

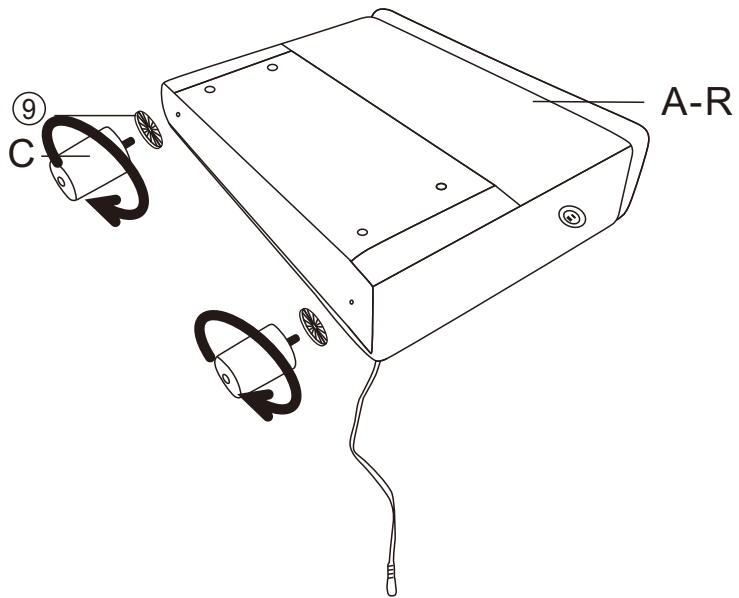

C		2PCS
⑨		2PCS

8

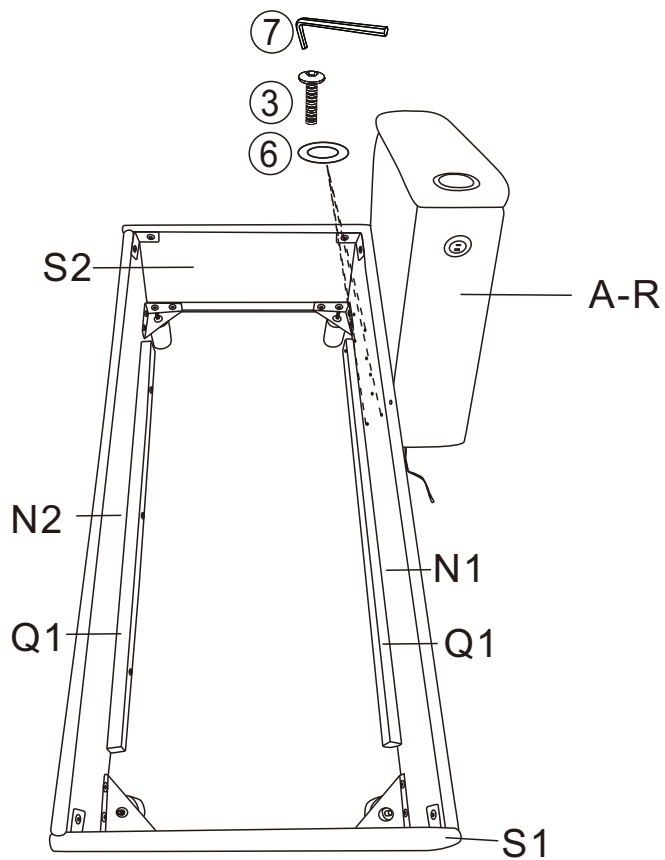

③		4PCS M6x45mm
⑥		4PCS
⑦		1PC



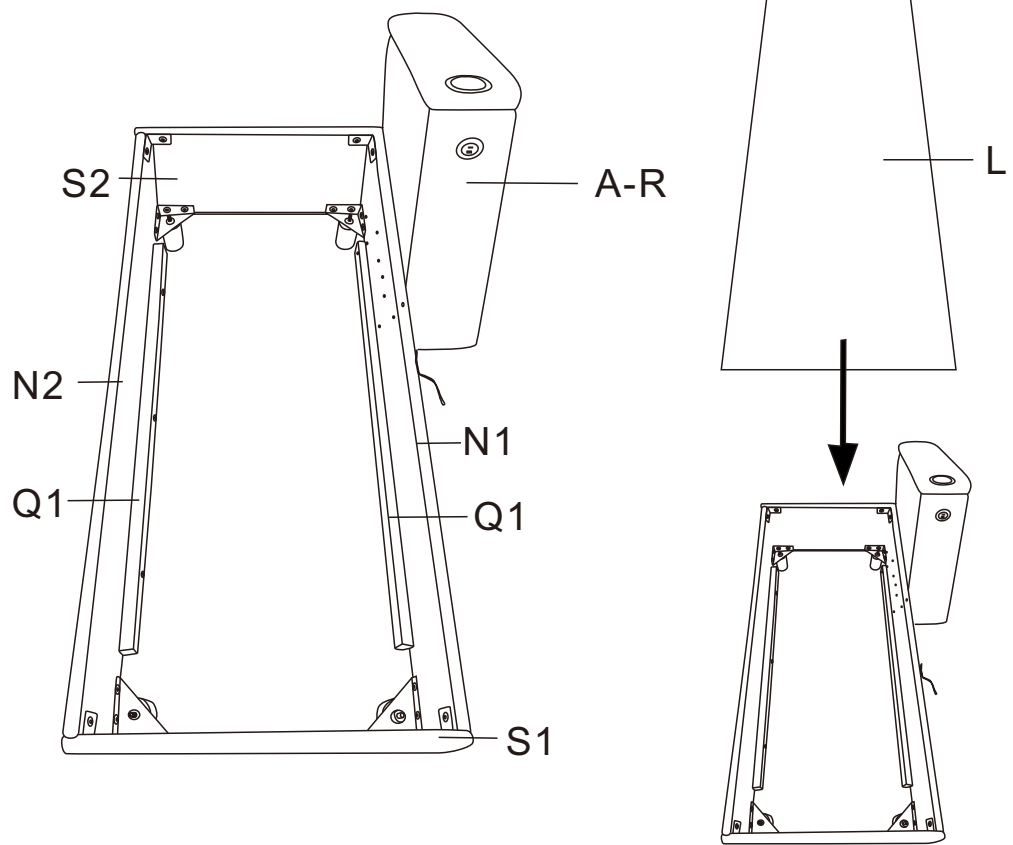

9

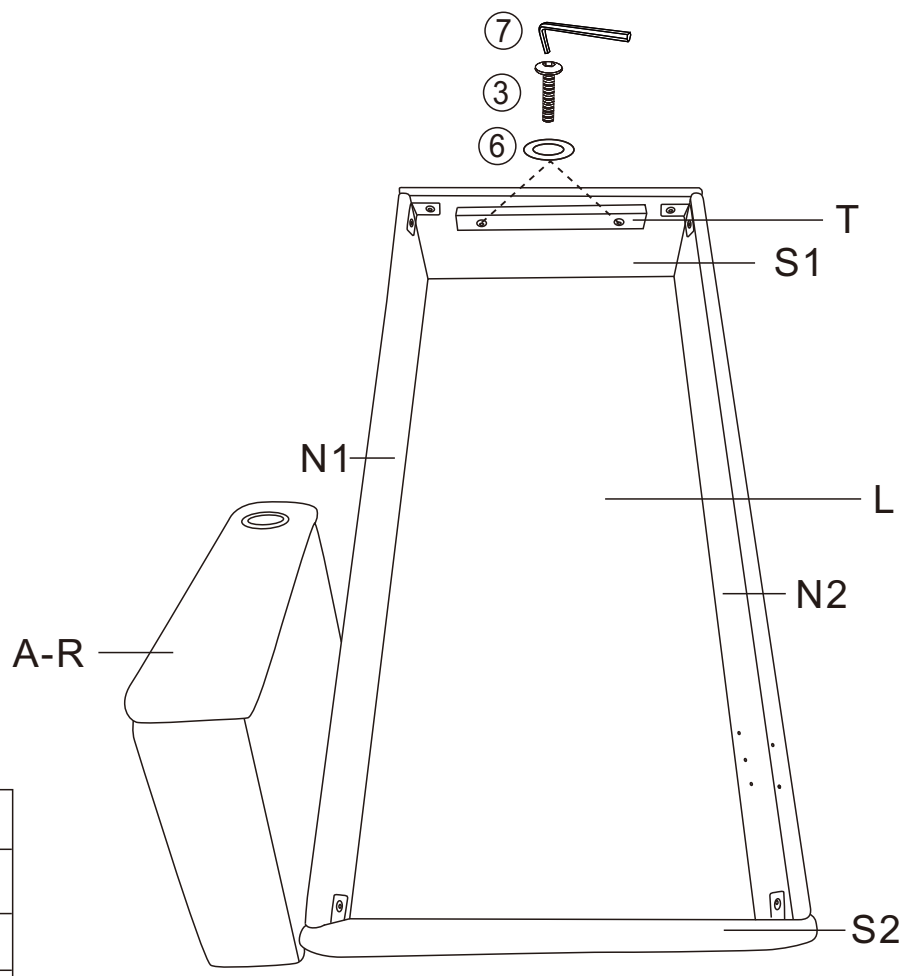

L		1PC
---	---	-----

10



T		1PC
③	 M6x45mm	2PCS
⑥		2PCS
⑦		1PC

11

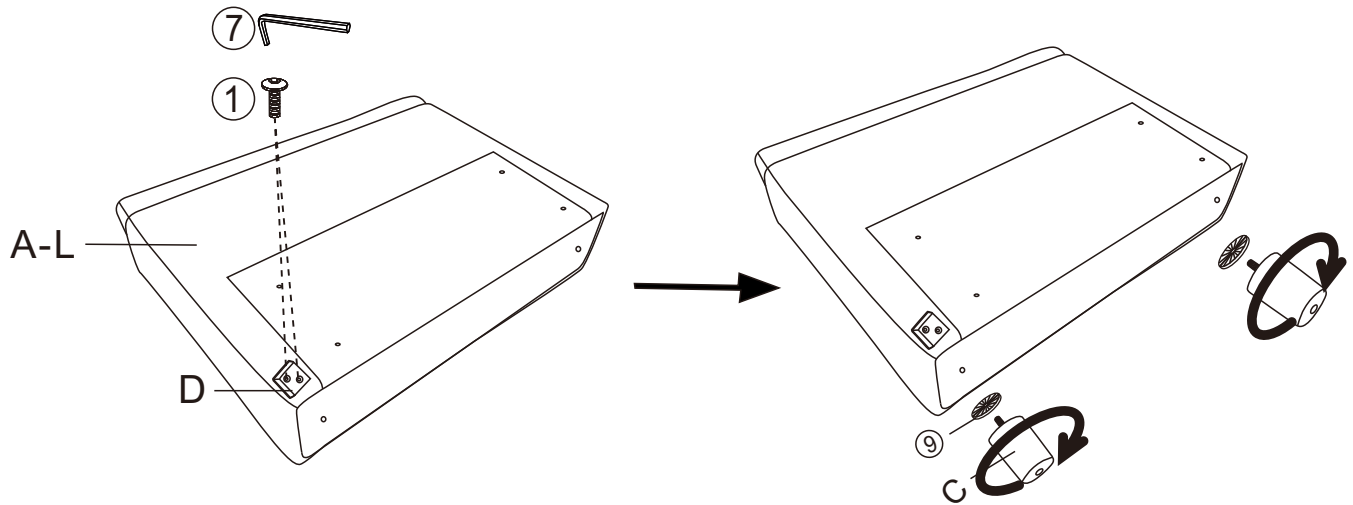

C		2PCS
D		1PC
①	 M6x20mm	2PCS
⑨		2PCS
⑦		1PC

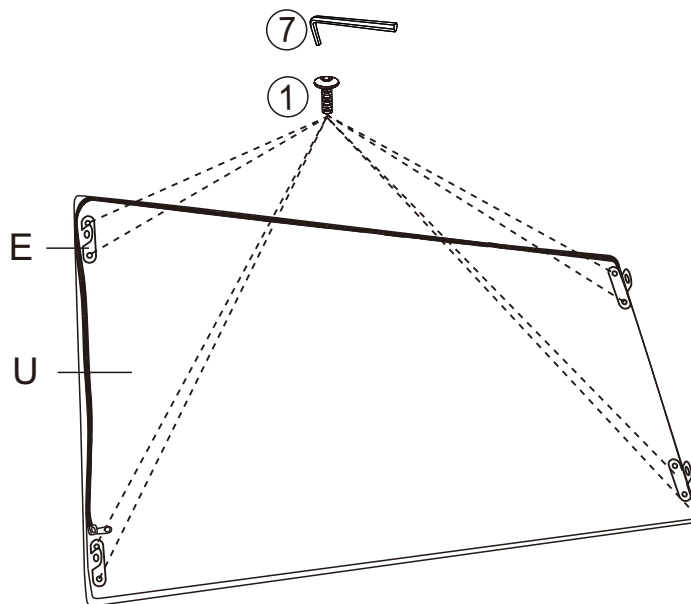

12



E		4PCS
U		1PC
①	 M6x20mm	8PCS
⑦		1PC

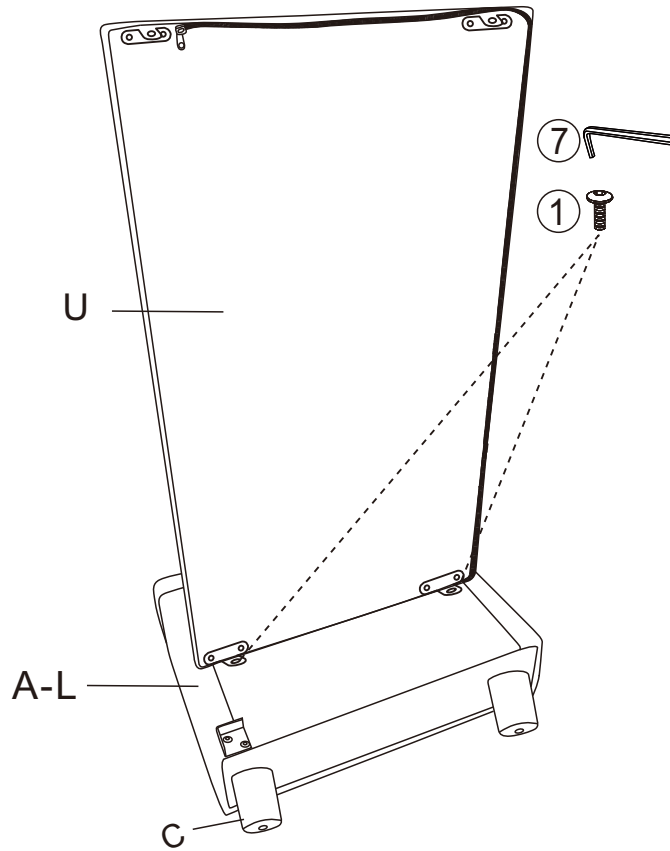

13

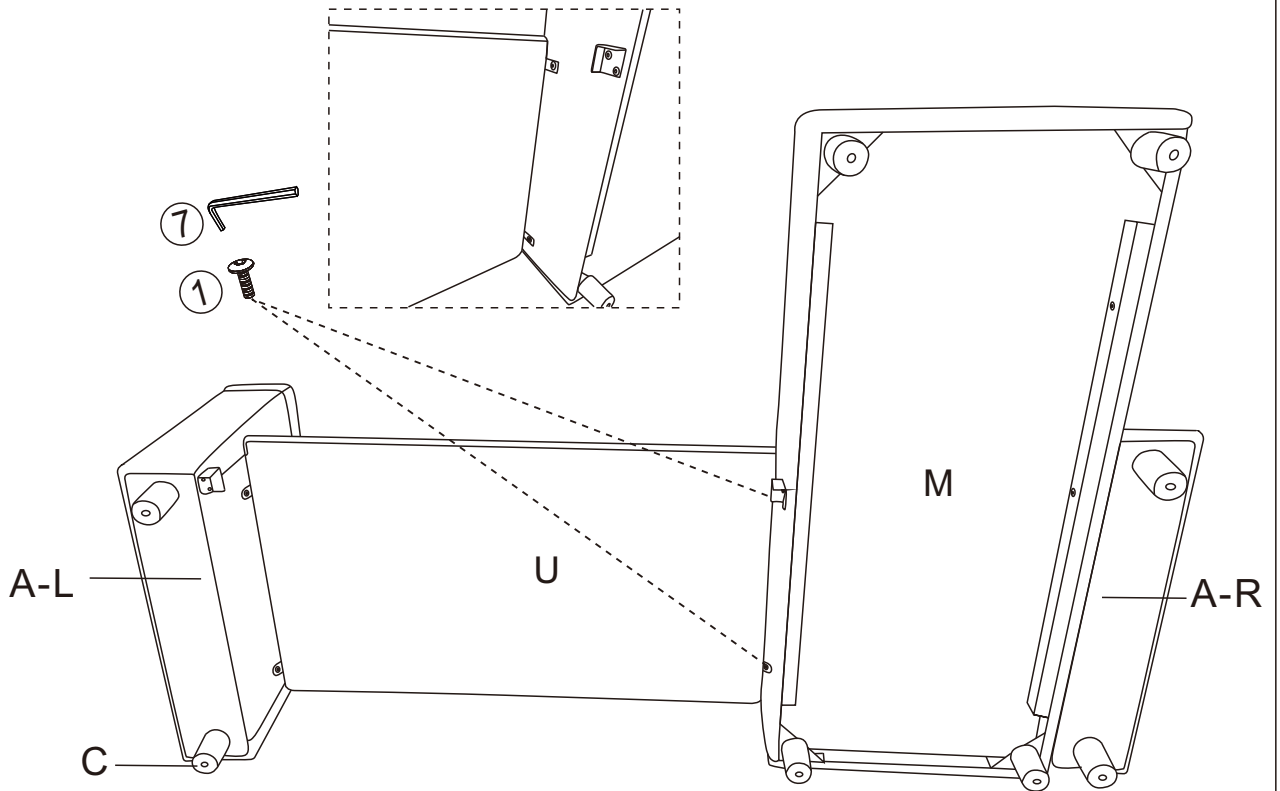

①	 M6x20mm	2PCS
⑦		1PC

14



①	 M6x20mm	2PCS
⑦		1PC

15

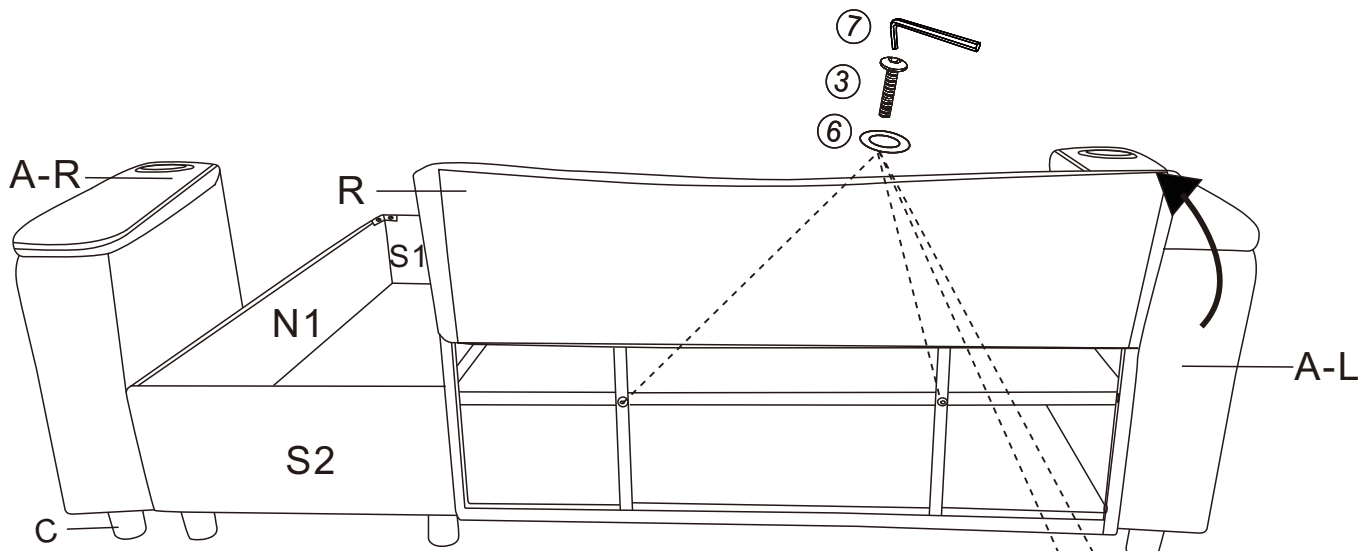

R		1PC
③	 M6x45mm	4PCS
⑥		4PCS
⑦		1PC

16

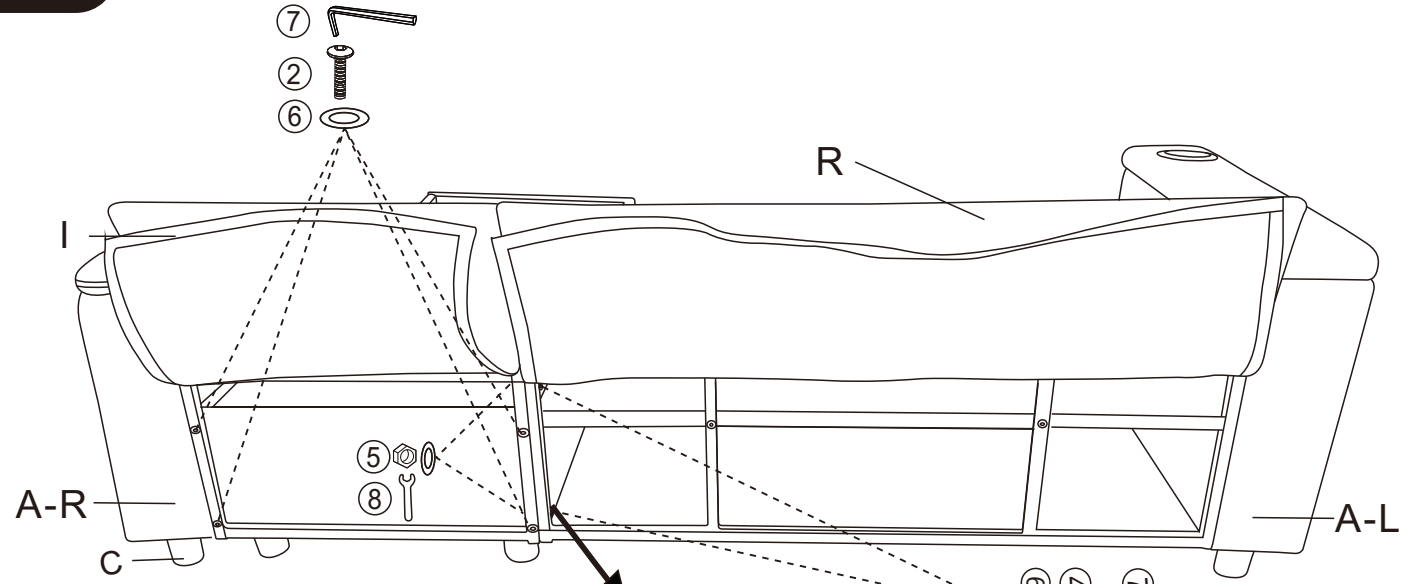

I		1PC
②	 M6x35mm	4PCS
④	 M6x50mm	2PCS
⑤		2PCS
⑥		8PCS
⑦		1PC
⑧		1PC

17

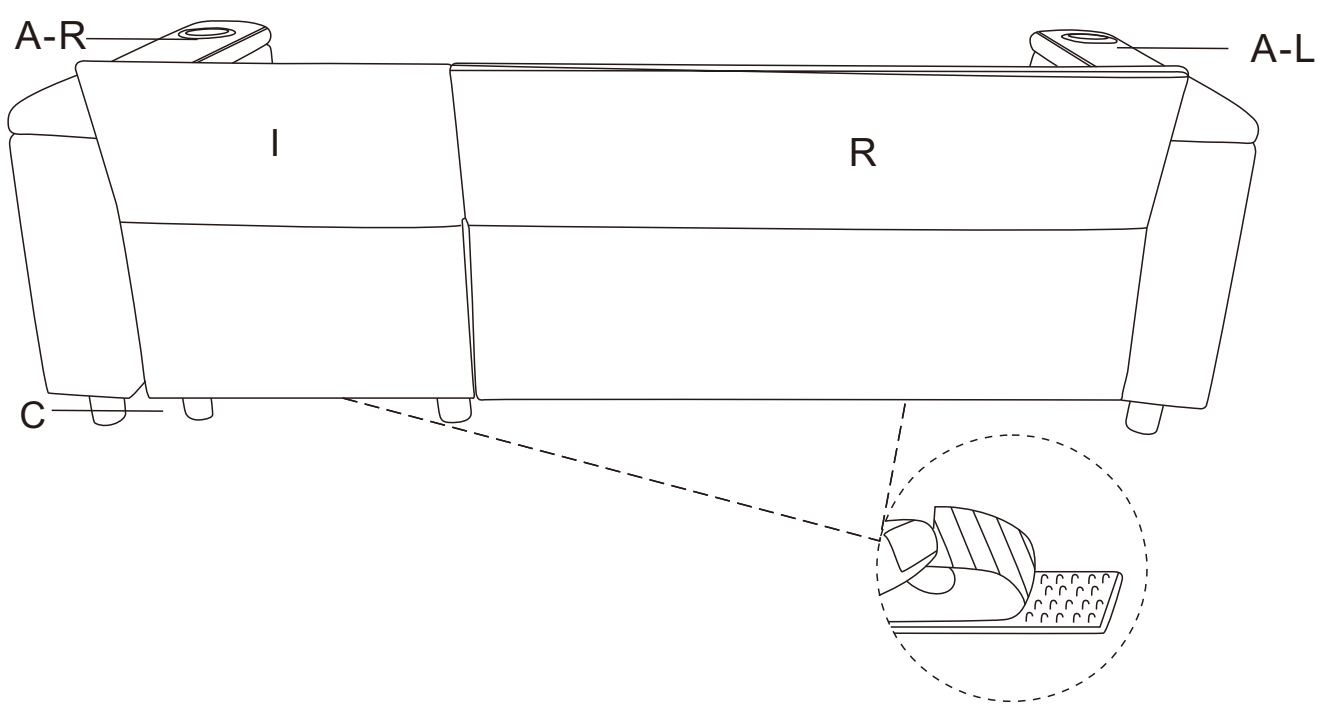



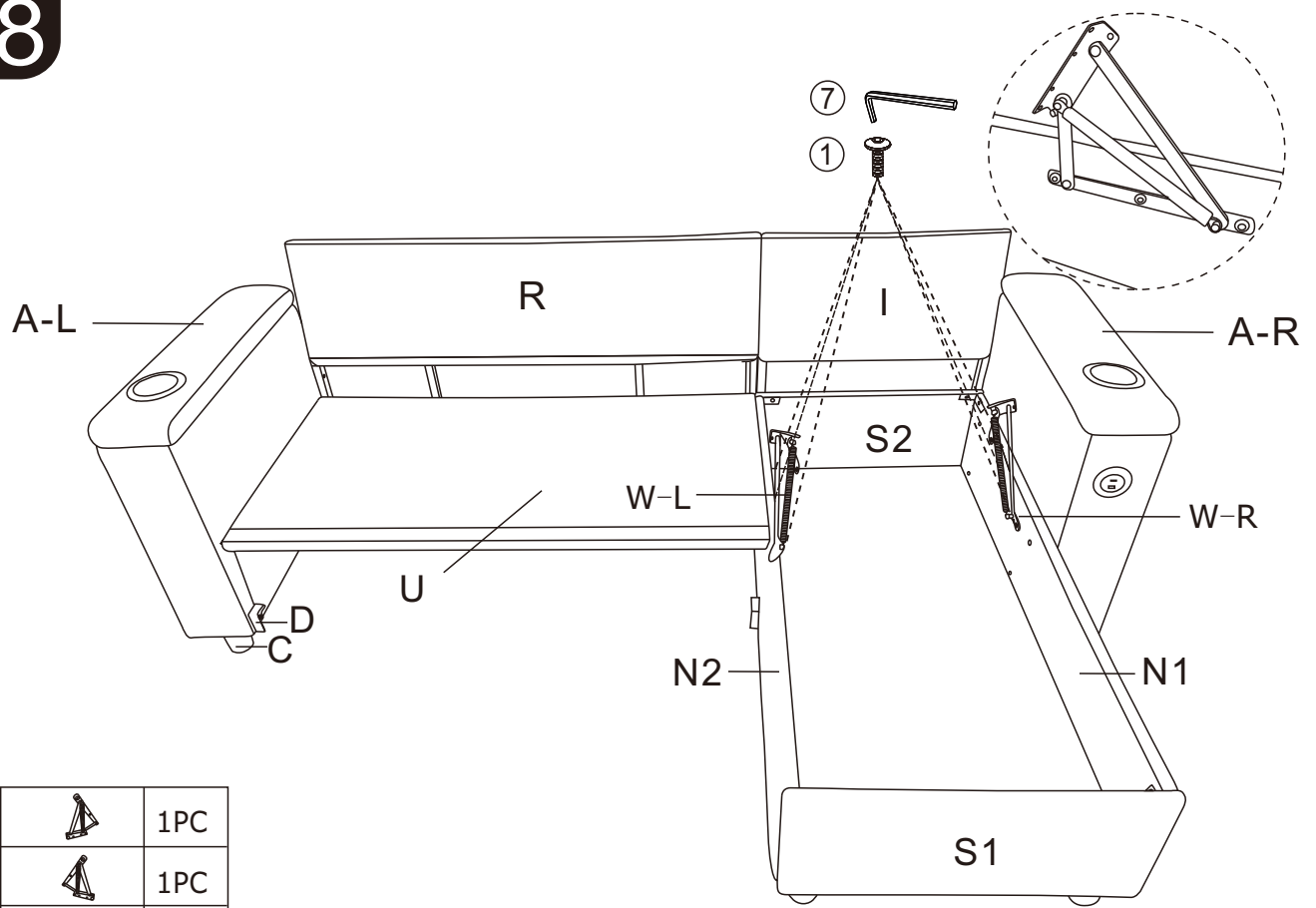

18

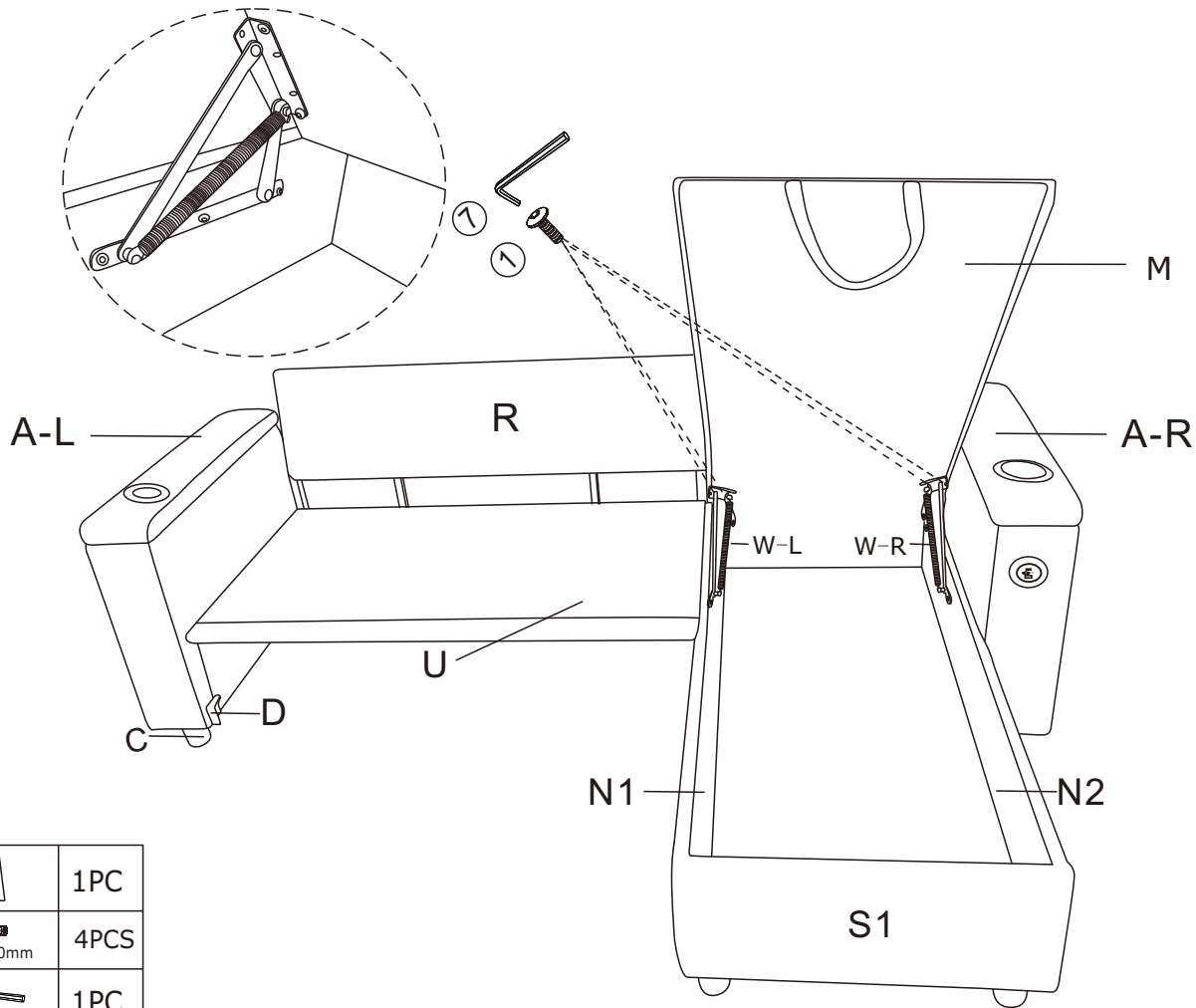

W-L		1PC
W-R		1PC
①	M6x20mm	6PCS
⑦		1PC

19



M		1PC
①	 M6x20mm	4PCS
⑦		1PC

20

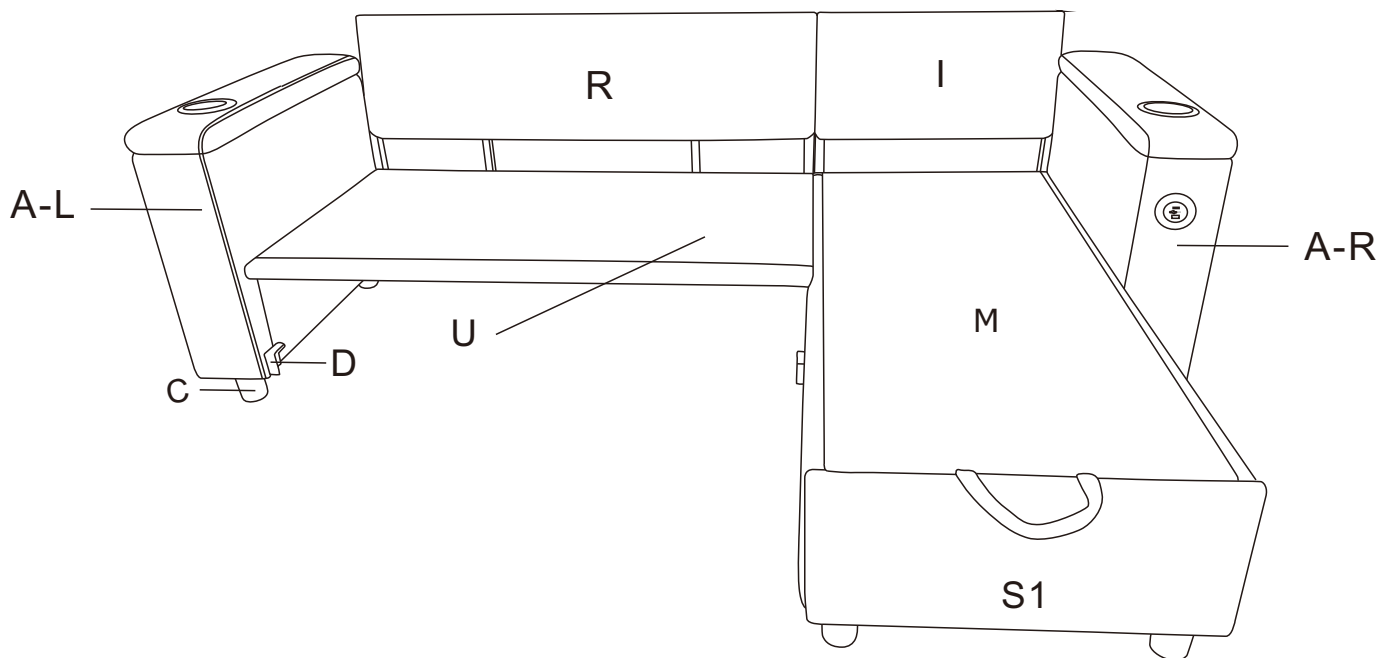

21

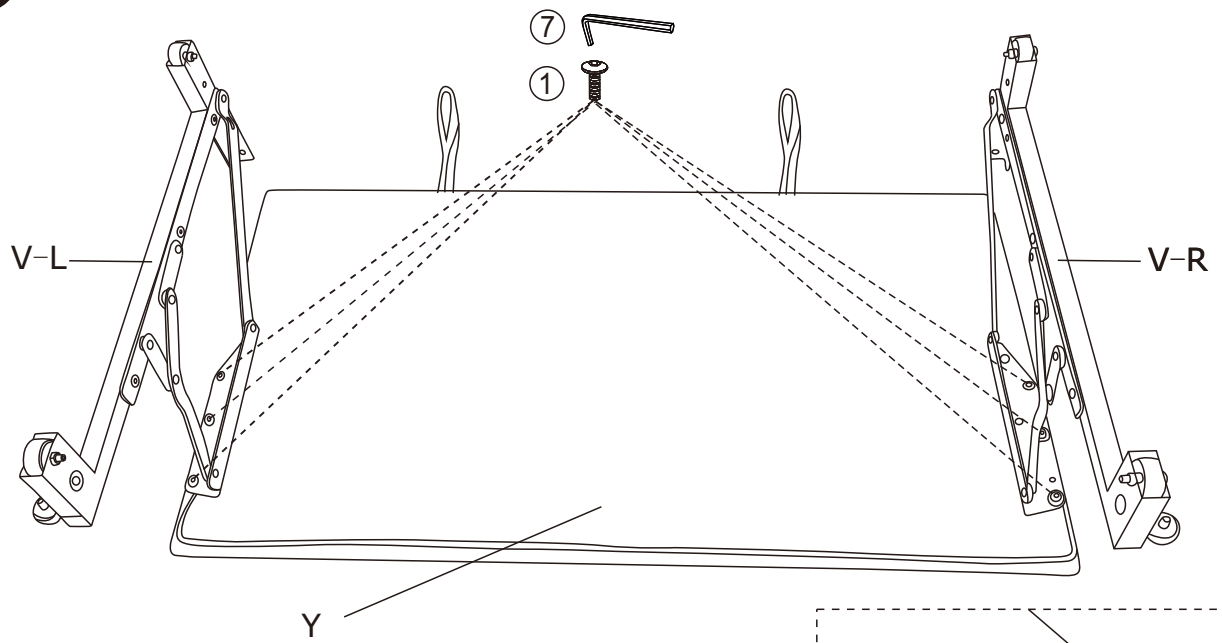

V-L		1PC
V-R		1PC
Y		1PC
①	 M6x20mm	6PCS
⑦		1PC

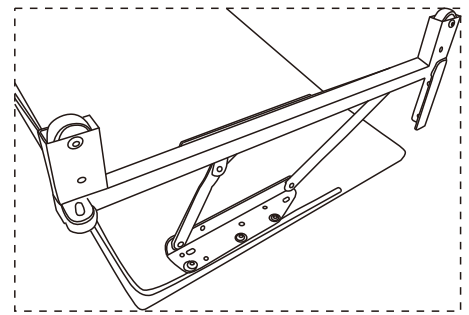

22

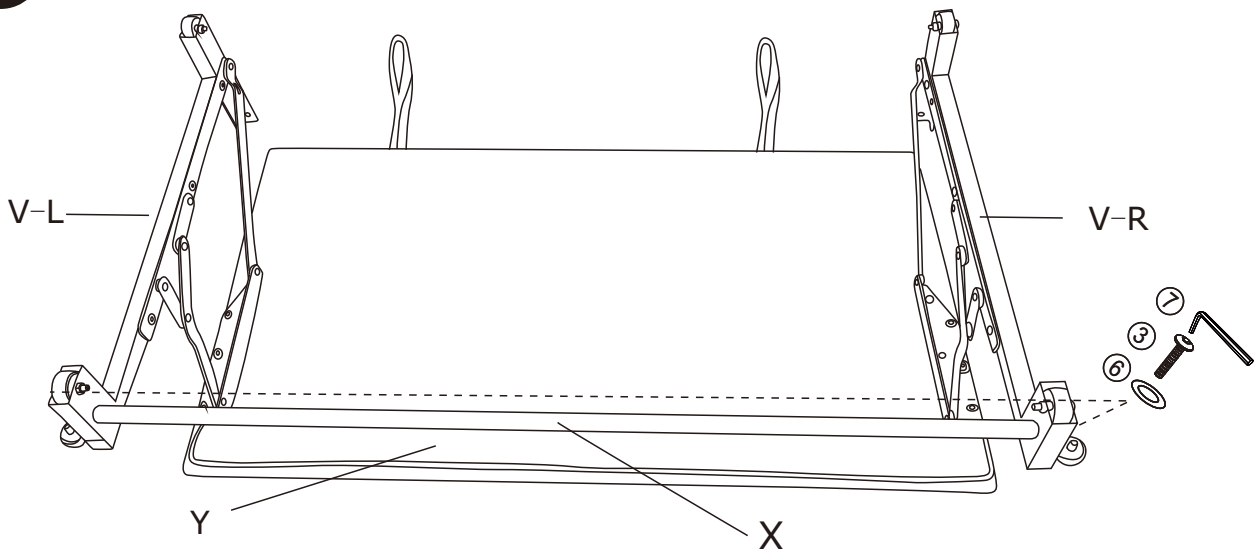

X		1PC
③	 M6x45mm	2PCS
⑥		2PCS
⑦		1PC

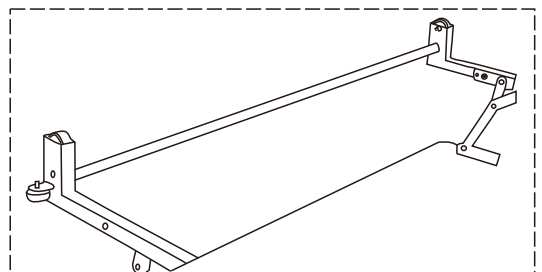

23

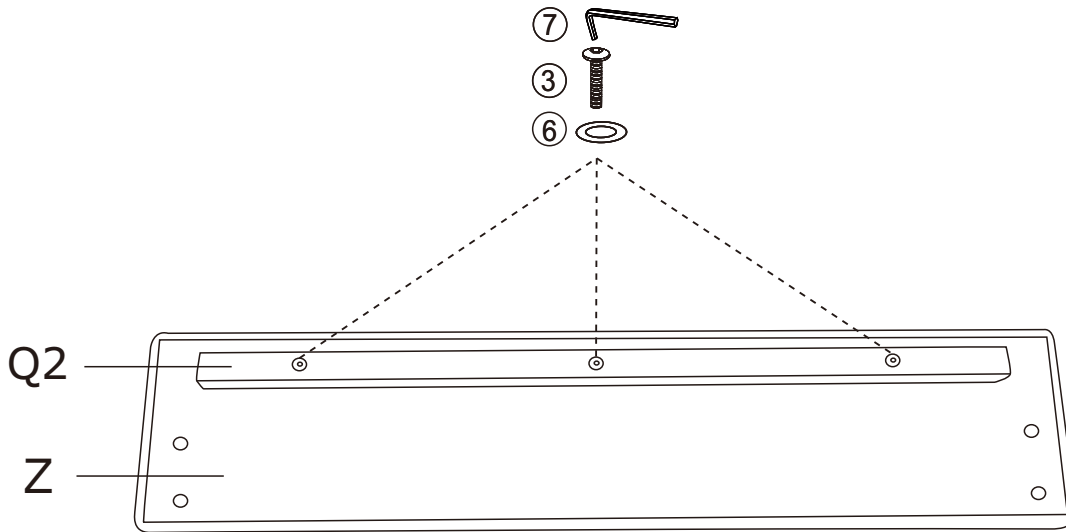

Q2		1PC
Z		1PC
③	M6x45mm	3PCS
⑥		3PCS
⑦		1PC

24

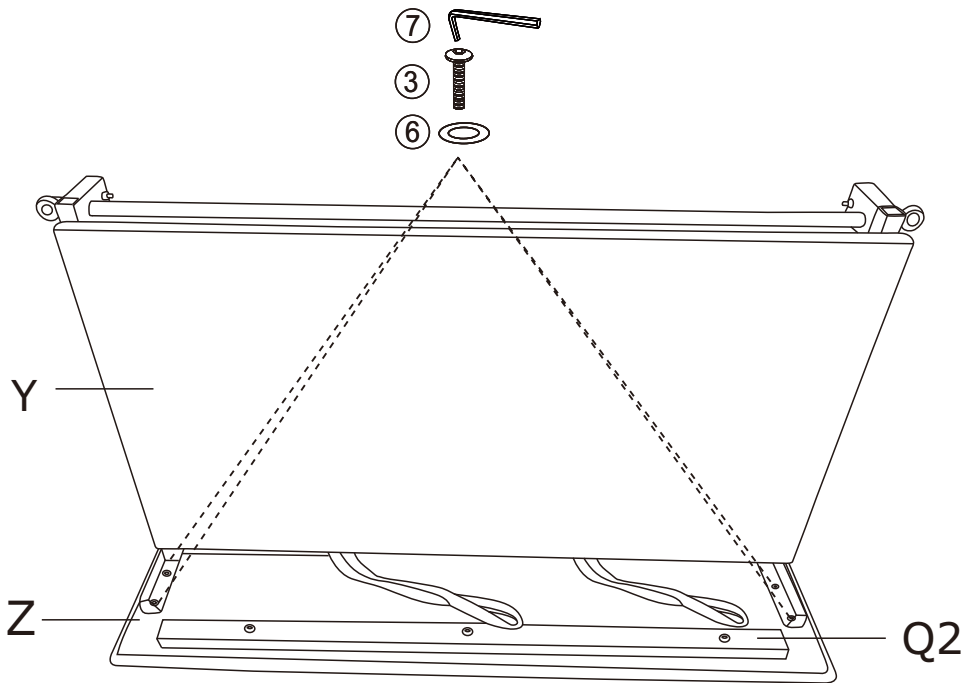

③	M6x45mm	4PCS
⑥		4PCS
⑦		1PC

25

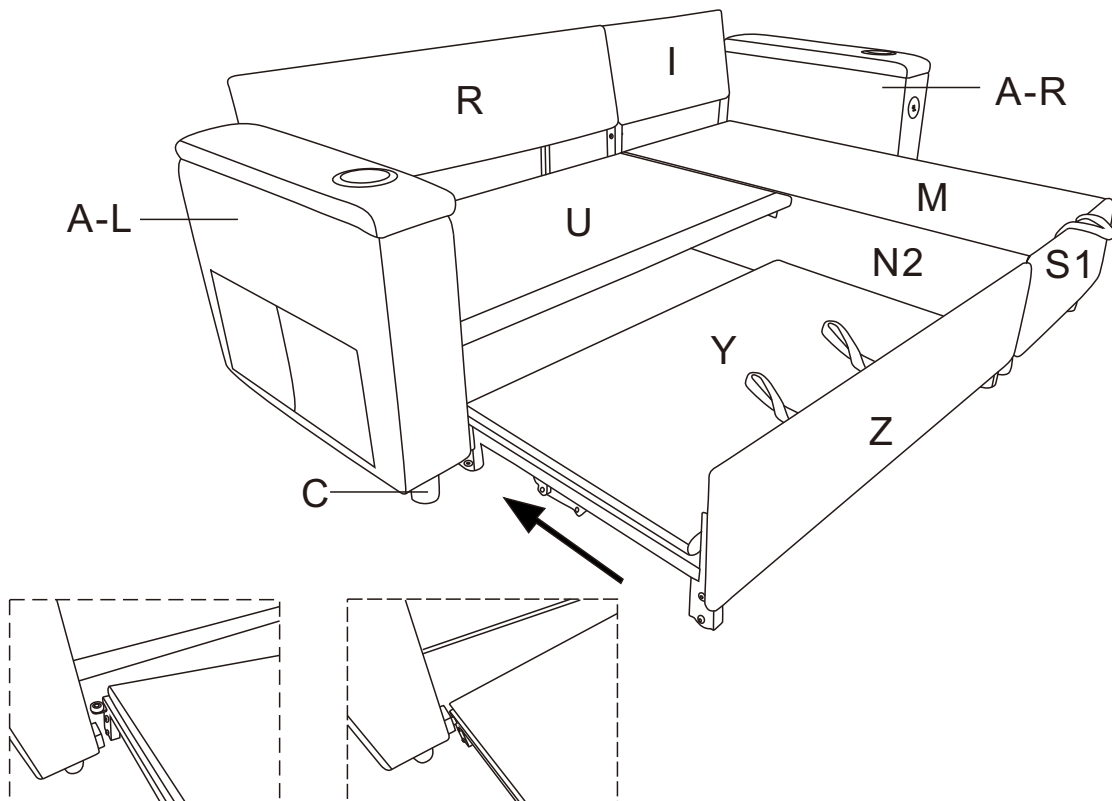

26

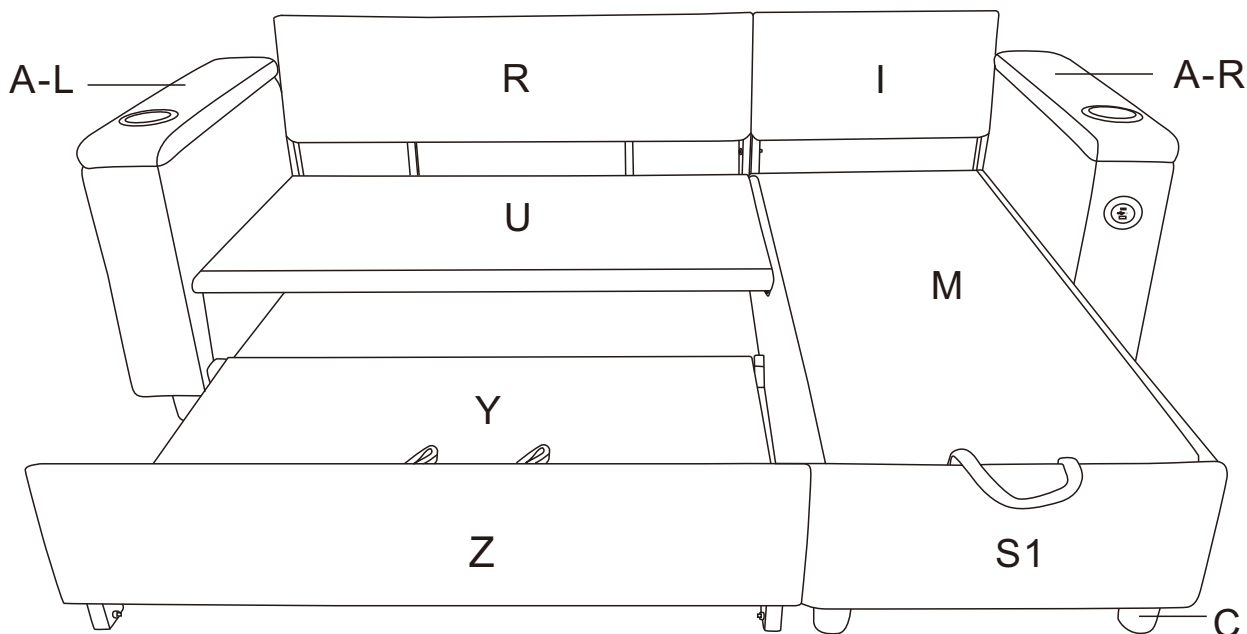



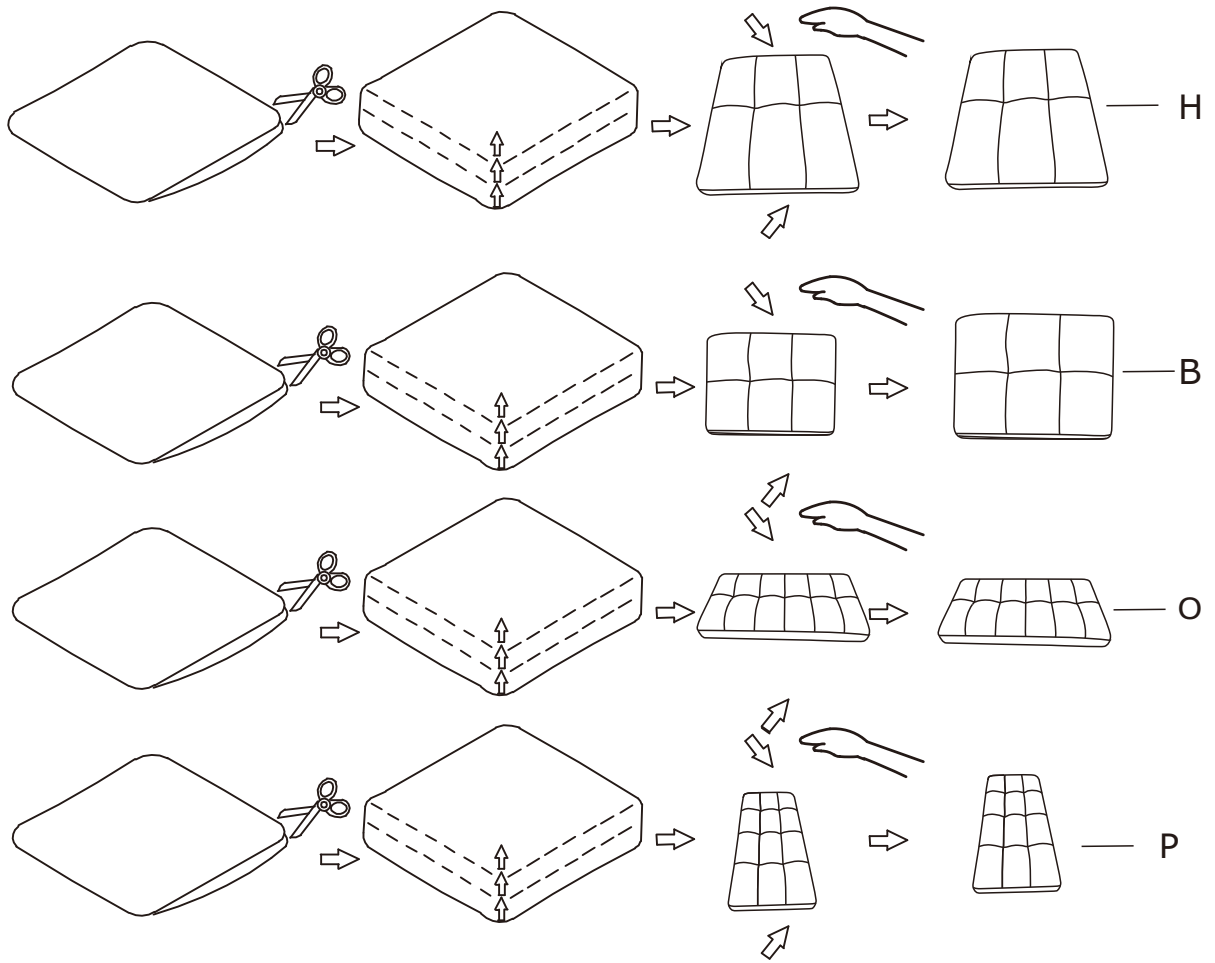

27

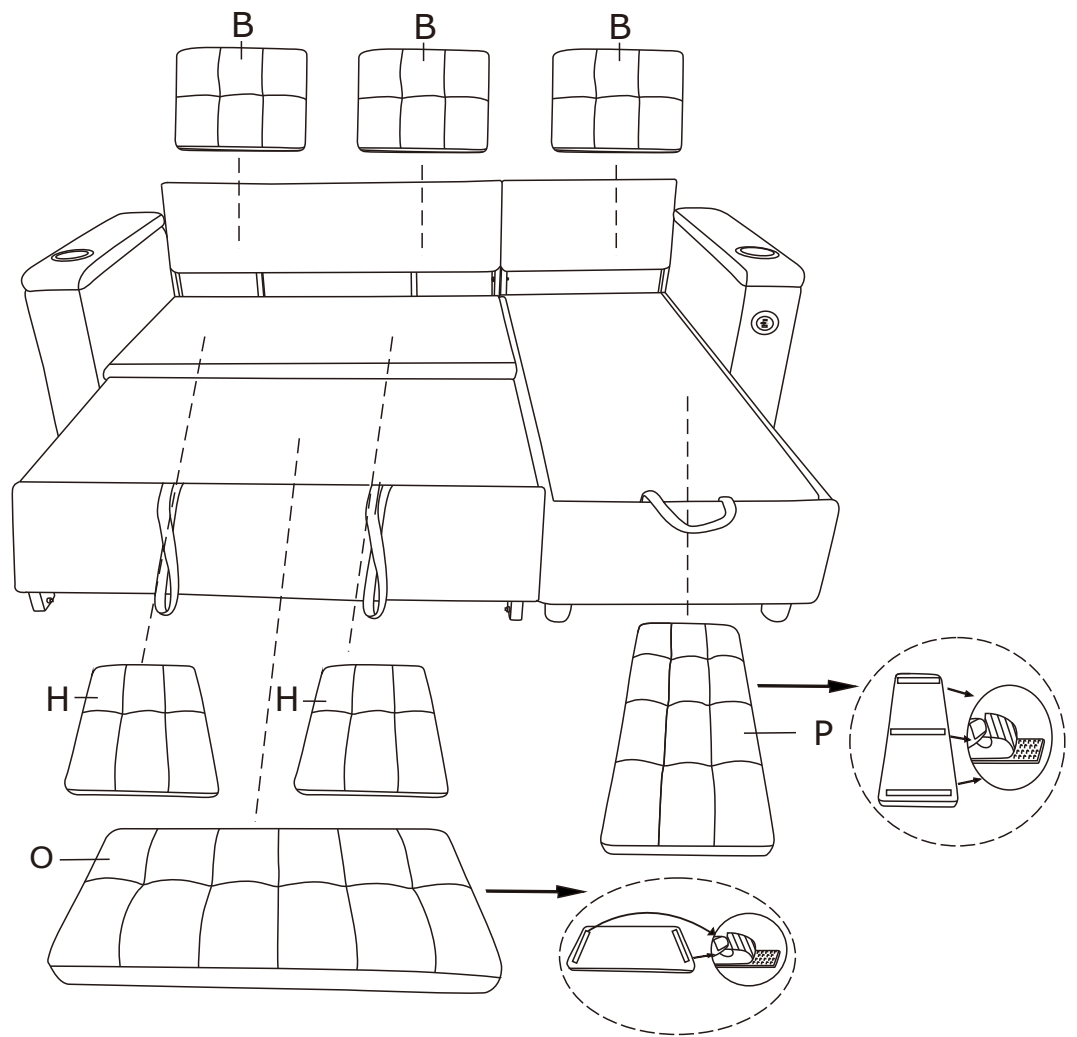

28



B		3PCS
H		2PCS
O		1PC
P		1PC

29

J

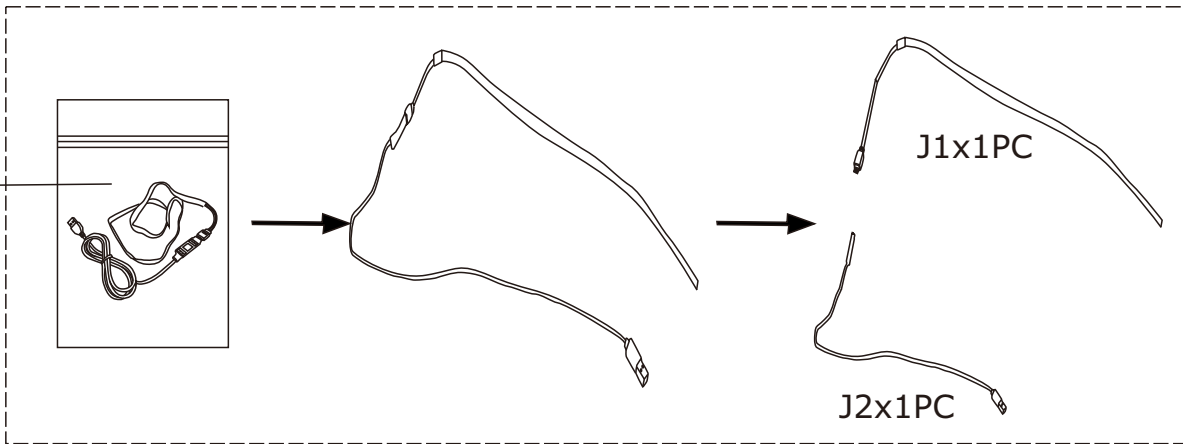

J

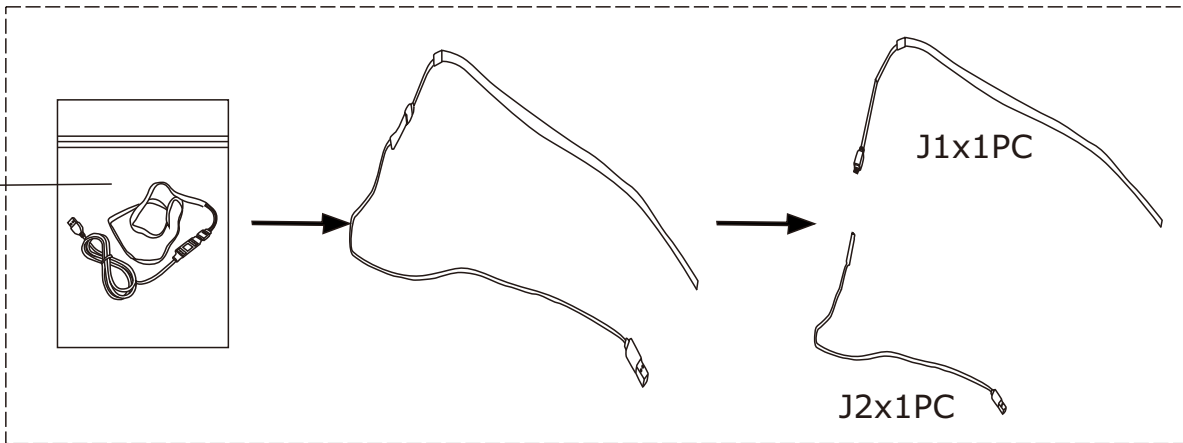

J		2PCS
---	--	------

30

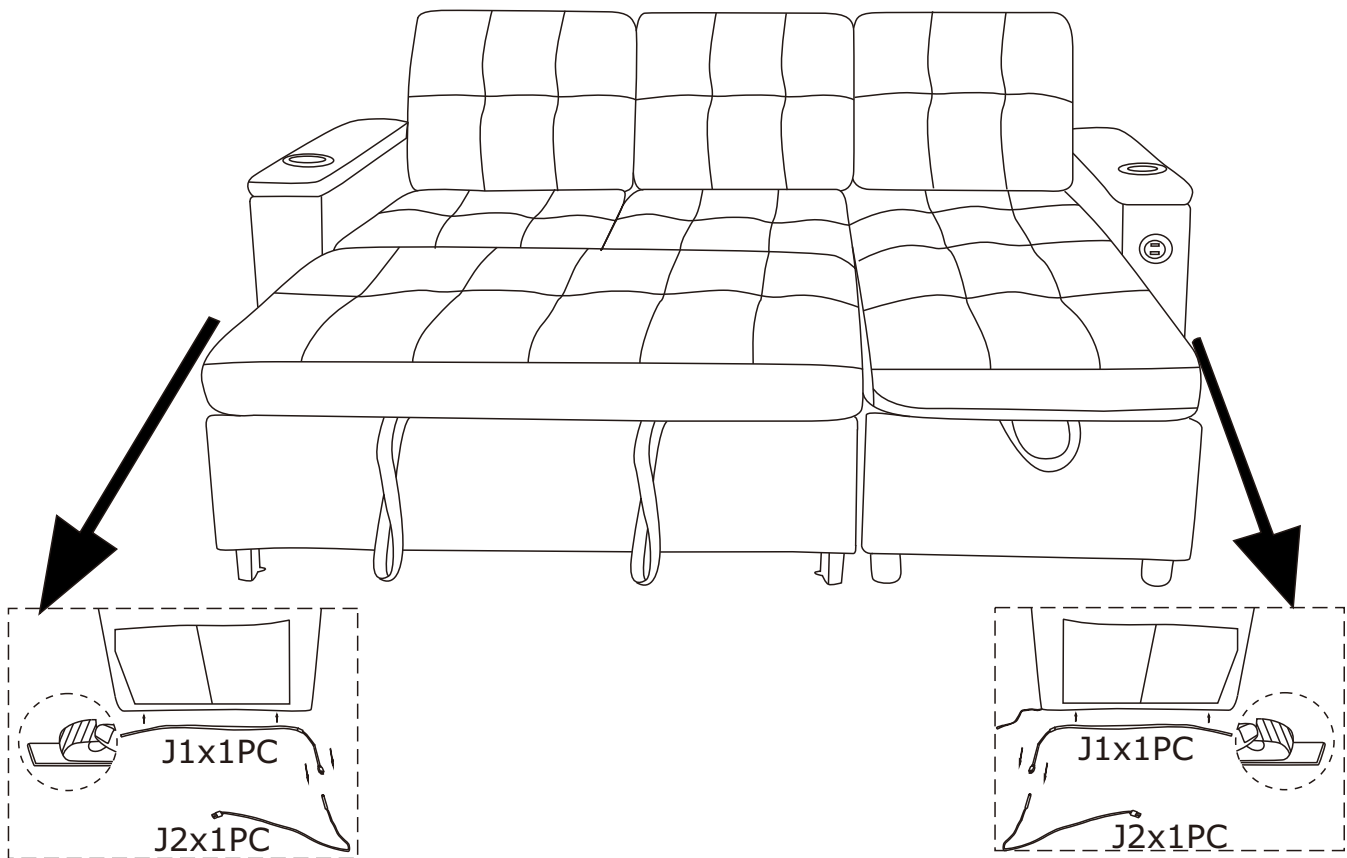



EN: Scan and download the following applications to control LED lights.

GE: Scannen und herunterladen Sie die folgenden Anwendungen, um LED-Leuchten zu steuern.

FR: Scannez ci - dessous télécharger l'application Control LED Light.

IT : Scansiona le seguenti applicazioni di download per controllare le luci LED.

ES: Escanee la siguiente aplicación de descarga para controlar las luces LED.

APP-PROGRAMMANWENDUNG

Klicken, um
Lampenliste
anzuzeigen
Farbrad
wechseln



Klicken für
Einstellungsansicht

Farbe anpassen

Farbanpassung
per Quadrat-
Symbol

Schnittstelle
durch Klicken
wechseln



HINWEIS:

Detaillierte Anleitung im
Menü "Guide"

PRODUKTPARAMETER

- Bluetooth: BLEVA 2
- Eingangsspannung: 4.5~26V
- Betriebstemperatur: -25~75 °C
- Abmessungen: 43×22×11 mm
- Gewicht: 30g
- Max. Leistung: 144W (24V)

VERBINDUNGSSCHRITTE

- ① LED-Farbstreifen & Controller verbinden, Controller einschalten
- ② App-Download
- ③ App starten, Controller suchen & verbinden
- ④ Bluetooth-Drahtlossteuerung genießen

PRODUKTMERKMALE

- Direkte Handy-Steuerung (20m Reichweite)
- Automatische Verbindung in 5 Sekunden
- Musikrhythmus-Synchronisation
- Gruppensteuerung
- Helligkeits-/Geschwindigkeitsregelung
- Unterstützt bis 10m RGB(W)-Streifen
- Automatische Sprachumschaltung (DE/EN)

ANIMATIONSEFFEKTE

- Farbverläufe
- Einfarbige/ Zweifarbige Gradienten
- Monochrome/Bunte Blinkereffekte
- Farbspringen
- Musikresponsive Effekte

APP PROGRAM USAGE



Click to display settings view

Adjust the color

Click square icon to adjust the color

Click to shift the interface



Notes:
detailed operating instructions,
enter the menu "Guide":

Product Paramters:
-Bluetooth:BLEV4.2
-Input Voltage:4.5~26V
-Working Temp:-25~75℃
-Size:43*22*11mm
-Weight:30g
-Max Power:144W(24V)

download APP

- ①Connect LED color strip and controller, power on controller
- ②download APP
- ③Start APP, search and connect controller
- ④Enjoy the Bluetooth wireless control experience

LED mobile phone Bluetooth controllerProduct Features

- LED Bluetooth controller is directly via mobilephone control remote distance can reach 20m without the need to setupeasy to connect open the software within 5 seconds you can automatically connect the controller
 - Flow the rhythm of the music changes
 - Group control
 - Brightness, speed addition and subtraction
 - Maximum can be 10 meters RGB(W)strip
 - The software shows that the text is based onthe language of the mobile phone set up automatic transformation of Chinese and English
- ANIMATION EFFECTS:
- Colorful gradient
 - All kinds of monochrome, double color gradient
 - All kinds of monochrome, double color, colorfull flashing
 - Colorful jump
 - Follow the thythm of the music chagnes

APP-PROGRAMMANWENDUNG

Afficher la
liste des lampes
Farbrad
Changer la
Roue chromatique

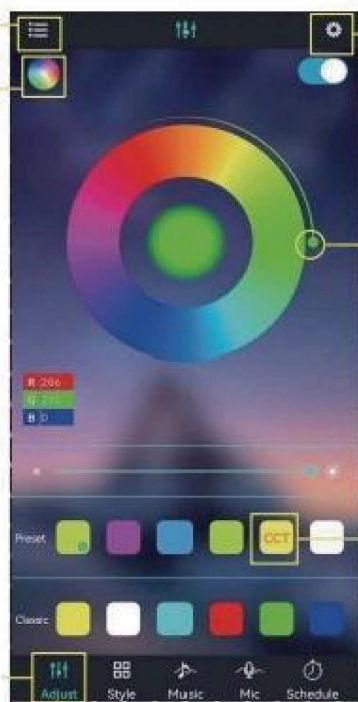

Afficher les
paramètres

Ajuster la couleur

Changer d'
interface
par clic

Cliquez sur l'icône
carrée pour ajuster
la couleur.



ÉTAPES DE CONNEXION

- ① Connecter bande LED & contrôleur, allumer
- ② télécharger l'app
- ③ Lancer l'app, rechercher & connecter
- ④ Profiter du contrôle Bluetooth sans fil

FONCTIONNALITÉS

- Contrôle direct par smartphone (20m)
- Connexion automatique en 5 secondes
- Synchronisation musicale
- Contrôle de groupe
- Réglage luminosité/vitesse
- Prise en charge bandes $\leq 10m$ RGB(W)
- Basculage automatique FR/EN

EFFETS D'ANIMATION

- Dégradés de couleurs
- Dégradés uni/bicolores
- Clignotements mono/colorés
- Saut de couleurs
- Effets réactifs à la musique

REMARQUE :

Guide détaillé dans le menu
"Guide"

CARACTÉRISTIQUES

- Bluetooth : BLEVA 2
- Tension d'entrée : 4.5~26V
- Température : -25~75° C
- Dimensions : 43×22×11 mm
- Poids : 30g
- Puissance max : 144W (24V)

UTILIZZO APP



PASSI CONNESSIONE

- ① Collega striscia LED & controller, accendi
- ② caricare APP
- ③ Avvia APP, cerca & connetti controller
- ④ Goditi controllo wireless Bluetooth

CARATTERISTICHE

- Controllo diretto smartphone (20m)
- Connessione automatica in 5 secondi
- Sincronizzazione ritmo musicale
- Controllo di gruppo
- Regolazione luminosità/velocità
- Supporto strisce $\leq 10m$ RGB(W)
- Auto switch IT/EN

EFFETTI ANIMAZIONE:

- Sfumature colore
- Gradienti mono/bicolori
- Luci lampeggianti mono/colorate
- Salto colori
- Effetti reattivi alla musica

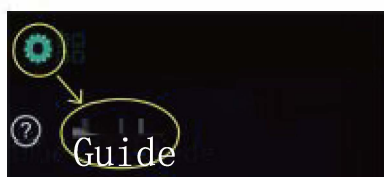

NOTA:

Guida completa nel menu "Guide"

SPECIFICHE:

- Bluetooth: BLEVA 2
- Tensione ingresso: 4.5~26V
- Temperatura: -25~75° C
- Dimensioni: 43×22×11 mm
- Peso: 30g
- Potenza max: 144W (24V)

USO DE LA APLICACIÓN

Mostrar lista de
Lámparas
Cambiar rueda de color

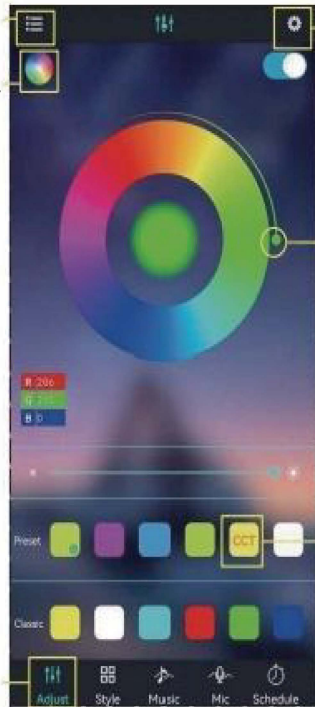

Ver ajustes

Ajustar el color

Cambiar interfaz
haciendo clic

Clic
Ajustar color
con icono cuadrado



PASOS DE CONEXIÓN

- ① Conectar tira LED y controlador, encender
- ② descargar APP:
- ③ Iniciar APP, buscar y conectar
- ④ Disfrutar control inalámbrico Bluetooth

CARACTERÍSTICAS

- Control directo móvil (20m alcance)
 - Conexión automática en 5 segundos
 - Sincronización ritmo musical
 - Control grupal
 - Ajuste brillo/velocidad
 - Soporte tiras $\leq 10m$ RGB(W)
 - Auto cambio ES/EN
- ### EFFECTOS DE ANIMACIÓN:
- Degradados de color
 - Transiciones mono/bicolores
 - Destellos monocromáticos/color
 - Salto de colores
 - Efectos reactivos a música

NOTA:

Guía completa en menú "Guide"

ESPECIFICACIONES:

- Bluetooth: BLEVA 2
- Voltaje entrada: 4.5~26V
- Temperatura: -25~75° C
- Tamaño: 43×22×11 mm
- Peso: 30g
- Potencia máx: 144W (24V)