

INSTRUCTIONS FOR INSTALLING YOUR WESLOCK PRODUCT

Traditionale Collection

Entry Handle Set
2100 Series



PARTS INCLUDED

Do not insert key or unlock handle before installation. Doing so may result in removal of the cylinder assembly.

Wood Screws (x8)

For mounting strikes & faceplates.



Faceplates (x4)

For covering a mortise latch.



* For Non-Mortise applications see below parts.

Strikes (x6)

Install on door frame.



XL 3" Wood Screws (x2)

For mounting strike (optional).



Exterior Deadbolt Assembly



Interior Deadbolt Assembly



Deadbolt Latch

Engages strike with door closed.



* For Non-Mortise applications see below parts.

Assembly Screws (x4)

For mounting interior deadbolt assembly.



* Only use two (2-1/4" OR 2-3/4") screws based on thickness of door.

Exterior Grip Assembly

Exterior handle & thumb piece.



Interior Knob/Lever Assembly

Interior knob / lever, rosette & spindle

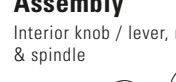

Thumb Press Latch

Engages strike with door closed.

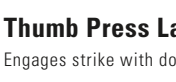

* For Non-Mortise applications see below parts.

Iron Door Latch Casing



* Slide over thumbpress latch for iron door application.

Foot Screw Cap Assembly

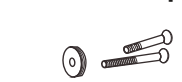

* Only use one (1-3/4" OR 2-1/4") screw based on thickness of door.

Assembly Screws (x2)

Pre-installed on Exterior Grip Assembly for mounting interior knob / lever assembly. 1-1/4"

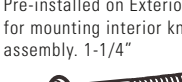

Entry Keys (x2)

For unlocking the deadbolt.

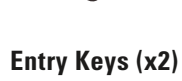

SCAN THE CODE FOR INSTALLATION VIDEOS



* Non-Mortise (Drive-In) Application

FACEPLATES (X4)



DEADBOLT LATCH



THUMB PRESS LATCH



REQUIRED TOOLS

Measuring Tape

Or other measuring tool

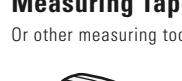

Screwdriver

Phillips and flat blade



Wood Chisel

* Only if prepping a new door



Writing Utensil

* Only if prepping a new door

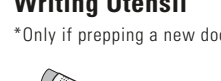

DOOR PREP INSTRUCTIONS 2 WESLOCK.COM

GLOSSARY OF TERMS

Technical language used in this document



MORTISE



CROSS BORE



EDGE BORE



THUMB PRESS LATCH



DEADBOLT LATCH

IDENTIFY THE LATCH TYPE FOR YOUR DEADBOLT AND THUMBPRESS LATCH

This will determine how you install the latch assembly in section 7.

MORTISE

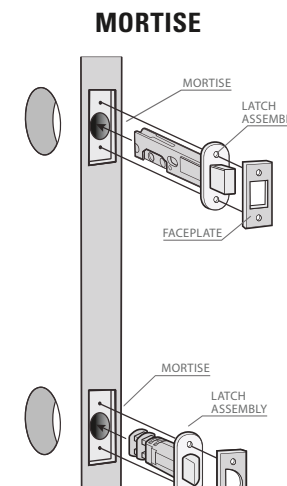

NON-MORTISE

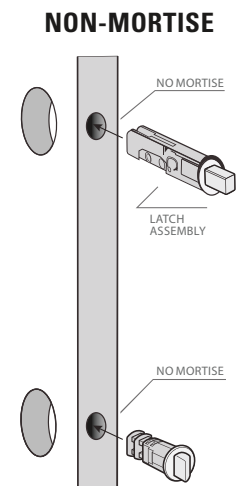

NON-MORTISE *Adapted

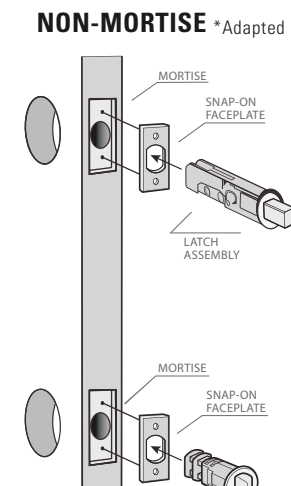

DETERMINE THE BACKSET OF YOUR DEADBOLT LATCH AND THUMBPRESS LATCH

The length of your latch assembly will be determined by your backset measurement.

MEASURE THE DOOR

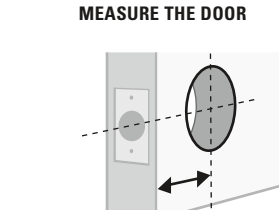

Measure distance between center of crossbore and edge of door.

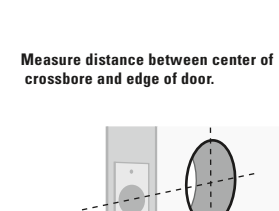

Measure distance between center of crossbore and edge of door.

IF MEASUREMENT = 2 3/8"

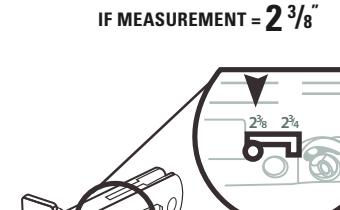

Latch leaves the factory with this setting. No adjustment is necessary.

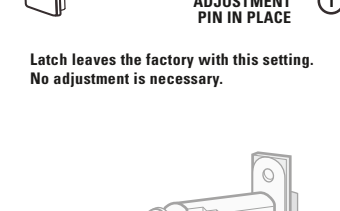

Remove extension

Pry extension to remove it from the latch assembly, using a flat blade screwdriver.

IF MEASUREMENT = 2 3/4"

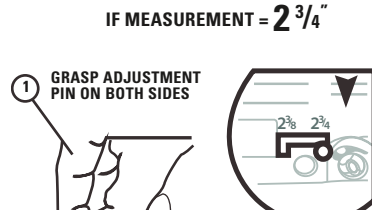

Slide adjustment pin back to 2 1/4" slot.

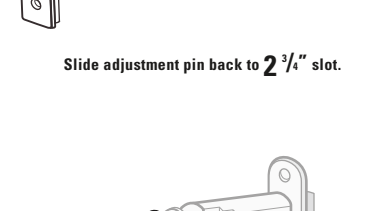

Keep extension in place

No adjustment is necessary. Leave extension attached to latch assembly.

ADJUSTING THE HANDING OF YOUR ENTRY HANDLE

To change right or left hand setting (factory setting is right hand) of the exterior side of the entry handle. The nylon block must be installed and is required for proper functionality of spindle.

A. Remove Nylon Block & Spindle

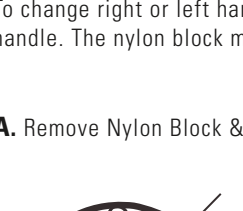

B. Replace Spindle & Nylon Block

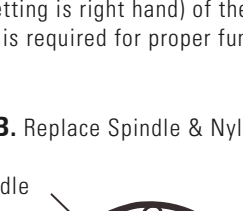

C Shaped Steel Spindle

Black Nylon Block

STEP 1

Using a screwdriver, slide the nylon block out of it's channel and remove from assembly.

STEP 2

With thumb and forefinger grab spindle, pull up and rotate 180°.

STEP 3

Reinsert nylon block on opposing side of assembly, adjacent to repositioned spindle.

INSTALLATION

Deadbolt latch must be extended prior to installation.

7A. Insert Mortise Latches

MORTISE

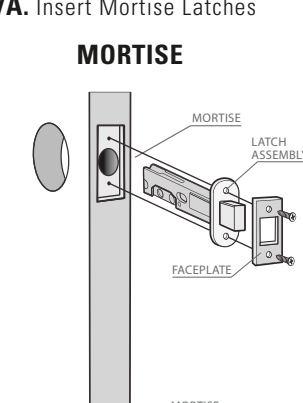

7B. Insert Non-Mortise Latches

NON-MORTISE

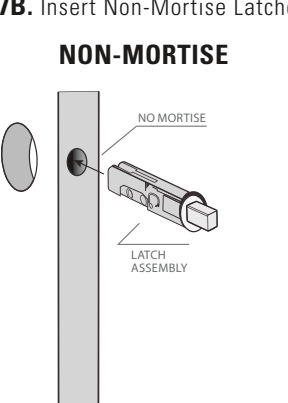

7C. Install Exterior Deadbolt and Grip Assemblies

A.

Insert deadbolt tailpiece into cam in deadbolt latch.

B.

Align notches on grip housing with proper grooves (2-3/8 or 2-3/4) on latch. Slide on. At same time, align and insert foot screw through pre-drilled hole.

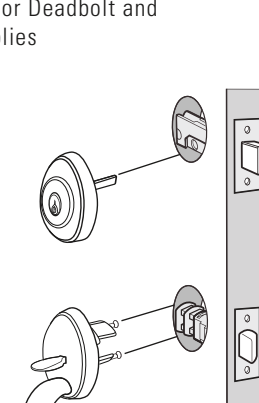

7D. Install Interior Deadbolt and Knob/Lever Assemblies

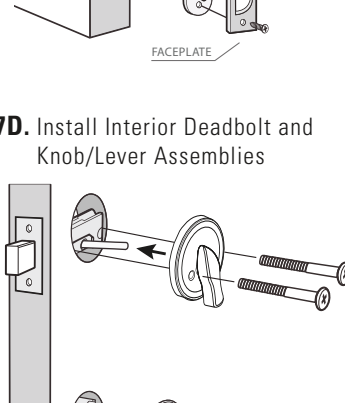

7E. Install Strikes



THANKS FOR CHOOSING US. WE HOPE YOU ENJOY YOUR NEW WESLOCK DOOR HANDLE.

WESLOCK WARRANTY INFORMATION

WESLOCK warrants to the purchaser that the products shall be free from defects in material workmanship for the LIFETIME of the product. Provided the product was purchased from an authorized WESLOCK dealer, Weslock's sole obligation under this warranty shall be to repair or replace product which WESLOCK determines to be defective. After such product is returned to WESLOCK by the purchaser with proof of purchase and with shipping charges prepaid, will this warranty be honored. Homeowner - if the product was installed as original equipment on a new home, you must provide the name of the builder, the date the home was built and your move-in date. If a mechanical defect has occurred, it is your right by this warranty to contact Customer Service in Tulsa, Oklahoma at (800) 575-2658 to arrange the return of the lock. This warranty DOES NOT cover products which malfunction due to improper installation or misuse. **Please register your product at Weslock.com.**

WARRANTY TERMS

Traditionale Collection

FINISH

Limited Lifetime

MECHANICAL

Limited Lifetime

ADDITIONAL CUSTOMER RESOURCES

Online

WEBSITE

For our full product catalog, and video instructions, go to;

@ www.weslock.com

TWITTER

To learn about promotions, and other news, follow us at;

@ twitter.com/Weslock1

YOUTUBE

Browse our video library, or leave us comments at;

@ youtube.com/WeslockDoorHardware

FACEBOOK

See what we're up to, or ask us a question at;

@ facebook.com/WeslockDoorHardware

Direct

PHONE NUMBER

1-800-575-2658
B O L T

FAX NUMBER

1-918-294-3869

EMAIL

customerservice@weslock.com
or
warranty@weslock.com

INSTRUCTIONS FOR INSTALLING YOUR WESLOCK PRODUCT

Traditionale Collection

Entry Handle Set
2100 Series



PARTS INCLUDED

Do not insert key, or unlock handle before installation. Doing so may result in removal of the cylinder assembly.

Wood Screws (x8)

For mounting strikes & faceplates.



Faceplates (x4)

For covering a mortise latch.

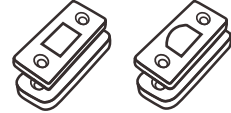

* For Non-Mortise applications see below parts.

Strikes (x6)

Install on door frame.

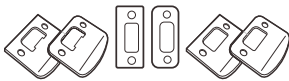

XL 3" Wood Screws (x2)

For mounting strike (optional).

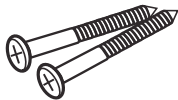

Exterior Deadbolt Assembly

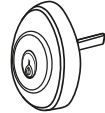

Interior Deadbolt Assembly



Exterior Grip Assembly

Exterior handle & thumb piece.



Iron Door Latch Casing



* Slide over thumbpress latch for iron door application.

Foot Screw Cap Assembly

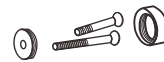

* Only use one (1-3/4" OR 2-1/4") screw based on thickness of door.

Deadbolt Latch

Engages strike with door closed.

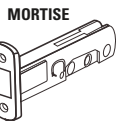

* For Non-Mortise applications see below parts.

Interior Knob/Lever Assembly

Interior knob / lever, rosette & spindle

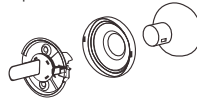

Assembly Screws (x2)

Pre-installed on Exterior Grip Assembly for mounting interior knob / lever assembly. 1-1/4"

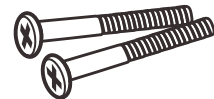

Assembly Screws (x4)

For mounting interior deadbolt assembly.

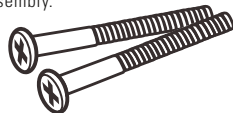

* Only use two (2-1/4" OR 2-3/4") screws based on thickness of door.

Thumb Press Latch

Engages strike with door closed.



* For Non-Mortise applications see below parts.

Entry Keys (x2)

For unlocking the deadbolt.



SCAN THE CODE FOR INSTALATION VIDEOS



*** Non-Mortise (Drive-In) Application**

FACEPLATES (X4)

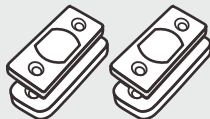

DEADBOLT LATCH

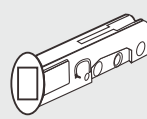

THUMB PRESS LATCH

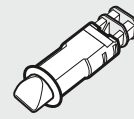

REQUIRED TOOLS

Measuring Tape

Or other measuring tool

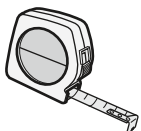

Screwdriver

Phillips and flat blade

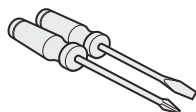

Wood Chisel

*Only if prepping a new door

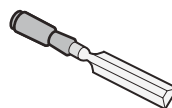

Writing Utensil

*Only if prepping a new door

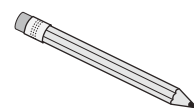

DOOR PREP INSTRUCTIONS 2 WESLOCK.COM

GLOSSARY OF TERMS

Technical language used in this document



MORTISE



CROSS BORE



THUMB PRESS LATCH



EDGE BORE



DEADBOLT LATCH

IDENTIFY THE LATCH TYPE FOR YOUR DEADBOLT AND THUMBPRESS LATCH

This will determine how you install the latch assembly in section 7.

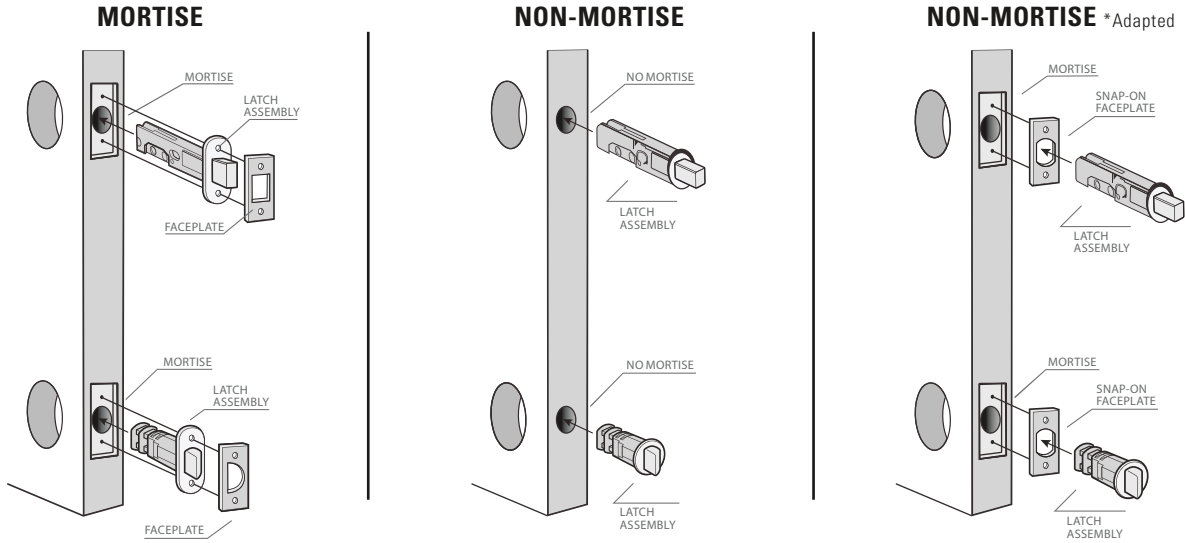

DETERMINE THE BACKSET OF YOUR DEADBOLT LATCH AND THUMBPRESS LATCH

The length of your latch assembly will be determined by your backset measurement.

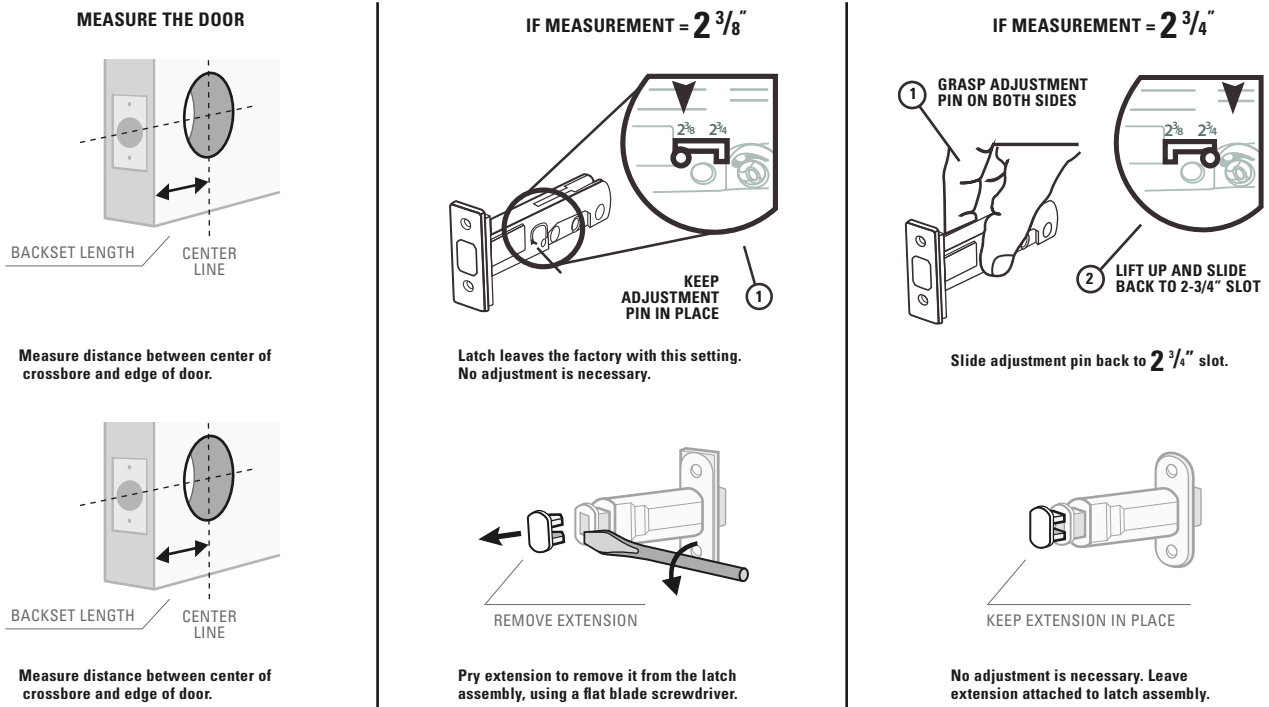

ADJUSTING THE HANDING OF YOUR ENTRY HANDLE

To change right or left hand setting (factory setting is right hand) of the exterior side of the entry handle. The nylon block must be installed and is required for proper functionality of spindle.

A. Remove Nylon Block & Spindle

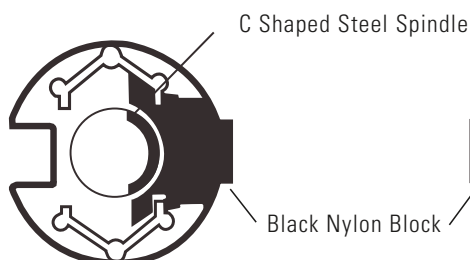

STEP 1

Using a screwdriver, slide the nylon block out of its channel and remove from assembly.

B. Replace Spindle & Nylon Block

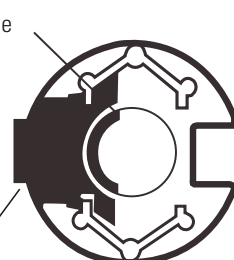

STEP 2

With thumb and forefinger grab spindle, pull up and rotate 180°.

STEP 3

Reinsert nylon block on opposing side of assembly, adjacent to repositioned spindle.

INSTALLATION

Deadbolt latch must be extended prior to installation.

7A. Insert Mortise Latches

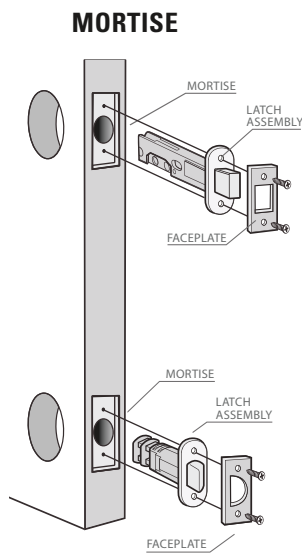

7B. Insert Non-Mortise Latches

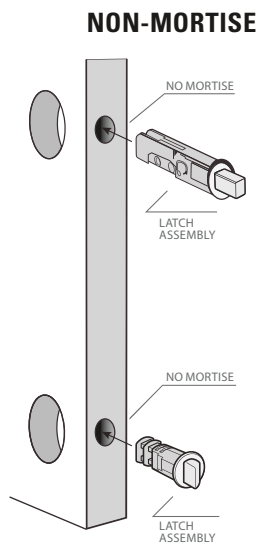

7C. Install Exterior Deadbolt and Grip Assemblies

A. Insert deadbolt tailpiece into cam in deadbolt latch.

B. Align notches on grip housing with proper grooves (2-3/8 or 2-3/4) on latch. Slide on. At same time, align and insert foot screw through pre-drilled hole.

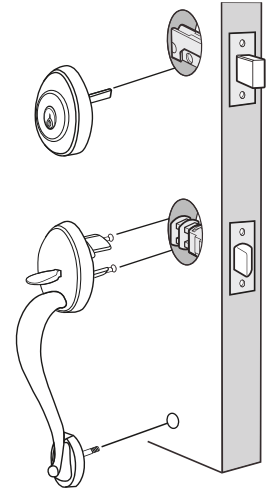

7D. Install Interior Deadbolt and Knob/Lever Assemblies

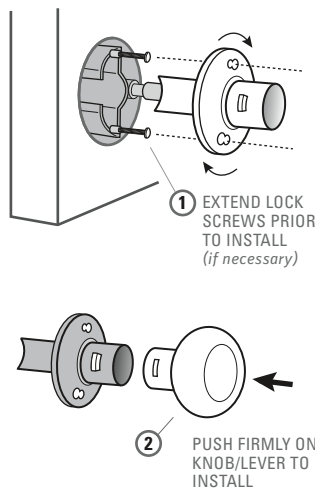
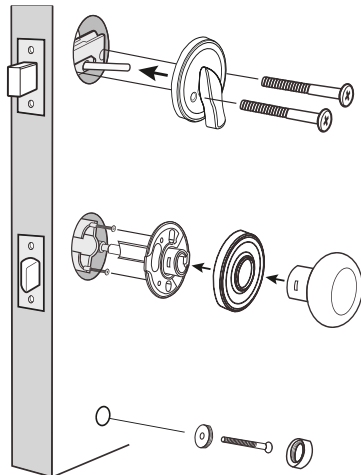

7E. Install Strikes

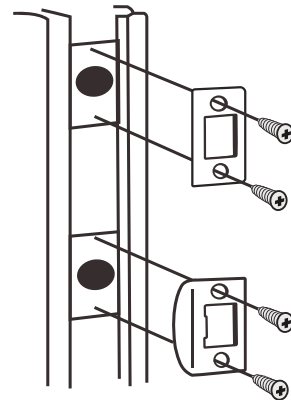

THANKS FOR CHOOSING US. WE HOPE YOU ENJOY YOUR NEW WESLOCK DOOR HANDLE.

WESLOCK WARRANTY INFORMATION

WESLOCK warrants to the purchaser that the products shall be free from defects in material workmanship for the LIFETIME of the product. Provided the product was purchased from an authorized WESLOCK dealer, Weslock's sole obligation under this warranty shall be to repair or replace product which WESLOCK determines to be defective. After such product is returned to WESLOCK by the purchaser with proof of purchase and with shipping charges prepaid, will this warranty be honored. Homeowner - if the product was installed as original equipment on a new home, you must provide the name of the builder, the date the home was built and your move-in date. If a mechanical defect has occurred, it is your right by this warranty to contact Customer Service in Tulsa, Oklahoma at (800) 575-2658 to arrange the return of the lock. This warranty DOES NOT cover products which malfunction due to improper installation or misuse. **Please register your product at Weslock.com.**

WARRANTY TERMS

Traditionale Collection

FINISH

Limited Lifetime

MECHANICAL

Limited Lifetime

ADDITIONAL CUSTOMER RESOURCES

Online

WEBSITE

For our full product catalog, and video instructions, go to;

www.weslock.com

TWITTER

To learn about promotions, and other news, follow us at;

twitter.com/Weslock1

YOUTUBE

Browse our video library, or leave us comments at;

youtube.com/WeslockDoorHardware

FACEBOOK

See what we're up to, or ask us a question at;

facebook.com/WeslockDoorHardware

Direct

PHONE NUMBER

1-800-575-2658
BOLT

FAX NUMBER

1-918-294-3869

EMAIL

customerservice@weslock.com
or
warranty@weslock.com