

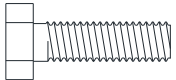
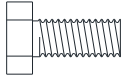









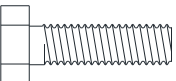




KD TABLE

INSTRUCTION MANUAL

REPLACEMENT PARTS LIST (HARDWARE)

PACKAGE	ITEM #	SAMPLE	DESCRIPTION	QTY.
LEG/PANEL	H1		HEX BOLT 3/8" x 2-3/8"	4
	H2		DOME WASHER 3/8" ID x 1-1/4" OD	4
	H3		HEX BOLT 5/16" x 1-1/4"	4
	H4		HEX BOLT 5/16" x 11/16"	24
	H5		WASHER 5/16" ID x 7/8" OD	28
	H6	/	/	/
	H7		FLAT HEAD SCREW 5/32" x 1-1/4"	8
	H8		FLAT HEAD SCREW 5/16" x 1-3/8"	8
BEAM/BLOCK	H9		HEX BOLT 5/16" x 2"	22
	H10		WASHER 5/16" ID x 7/8" OD	22
	H11	/	/	/
	H12		FLAT HEAD SCREW 5/32" x 1-1/2"	4
RAIL/PACKET/SLATE	H13		HEX BOLT 3/8" x 2-3/8"	18
	H14		DOME WASHER 3/8" ID x 1-1/4" OD	18
	H15		FLAT HEAD SCREW 3/8" x 2-3/4"	12
	H16		HEX BOLT 5/16" x 1"	12
	H17		WASHER 5/16" ID x 7/8" OD	12
	H18		FLAT HEAD SCREW 1/8" x 5/8"	30

REPLACEMENT PARTS LIST


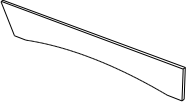


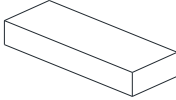

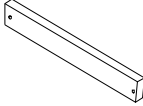
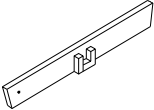





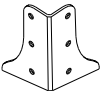
PACKAGE	ITEM #	SAMPLE	DESCRIPTION	QTY.	
LEG	1		LEG	4	
	FRAME (PANEL)	2		SIDE CABINET PANEL	2
		3		END CABINET PANEL	2
		4		SHORT WOODEN BLOCK	4
		4a		LONG WOODEN BLOCK	4
		5		CORNER POST	4
		6		CENTER BEAM	3
MDF/BEAM	7		CROSS BEAM	2	
	8	/	/	/	
	9	/	/	/	
TOP RAIL	10		TOP RAIL LEFT SIDE	2	
	11		TOP RAIL RIGHT SIDE	2	
	12		TOP RAIL END	2	
HARDWARE	13		SIDE POCKET	2	
	14		CORNER POCKET	4	
	15		LEG BRACKET	4	

FIG.1

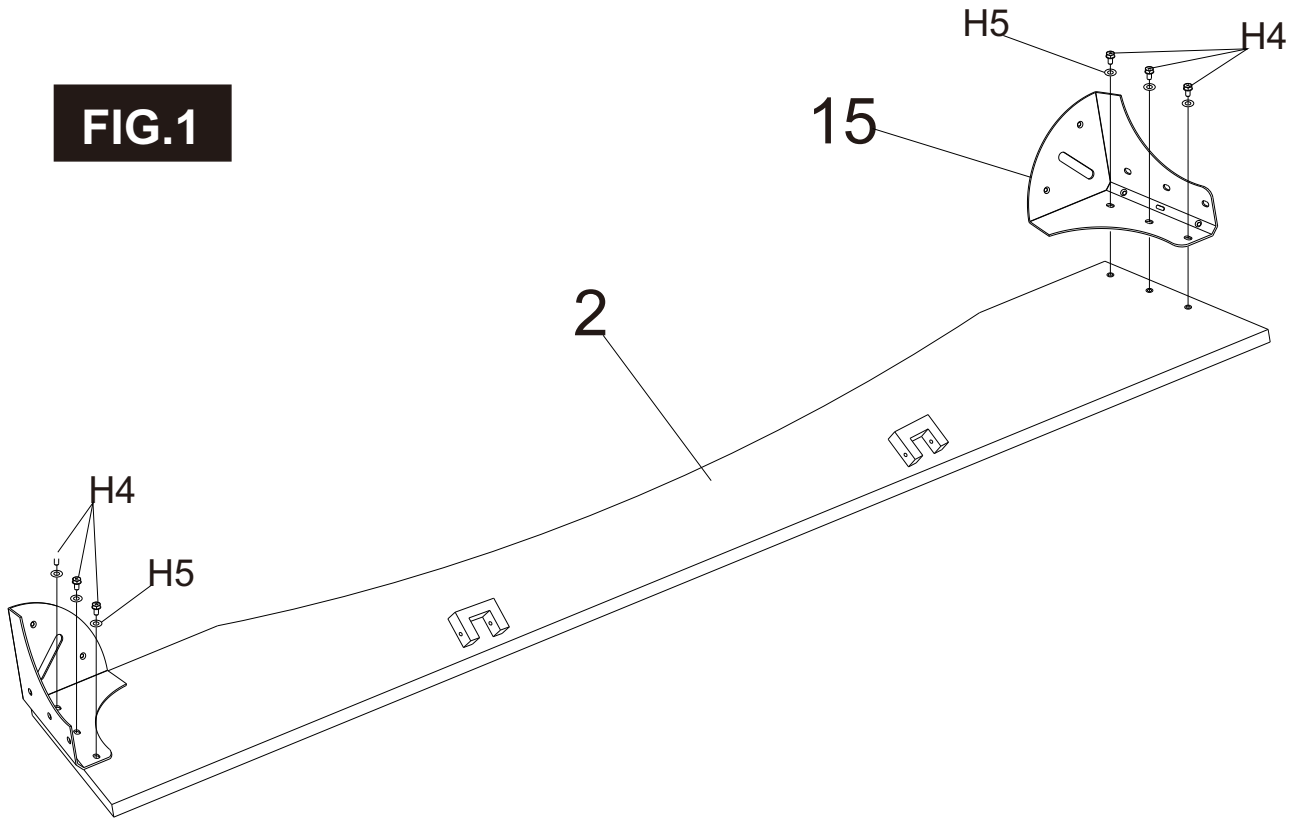


FIG.2

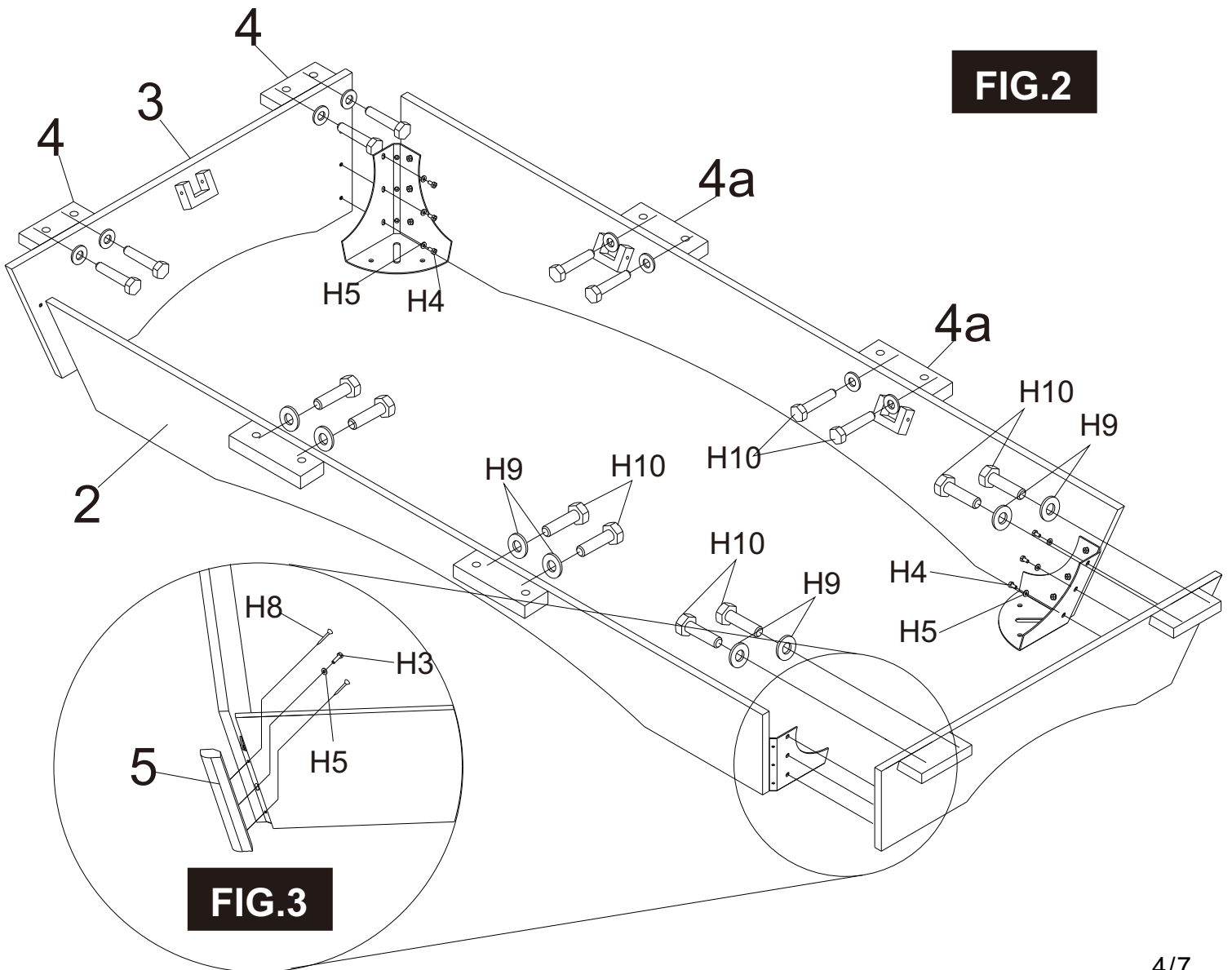


FIG.3

FIG.4

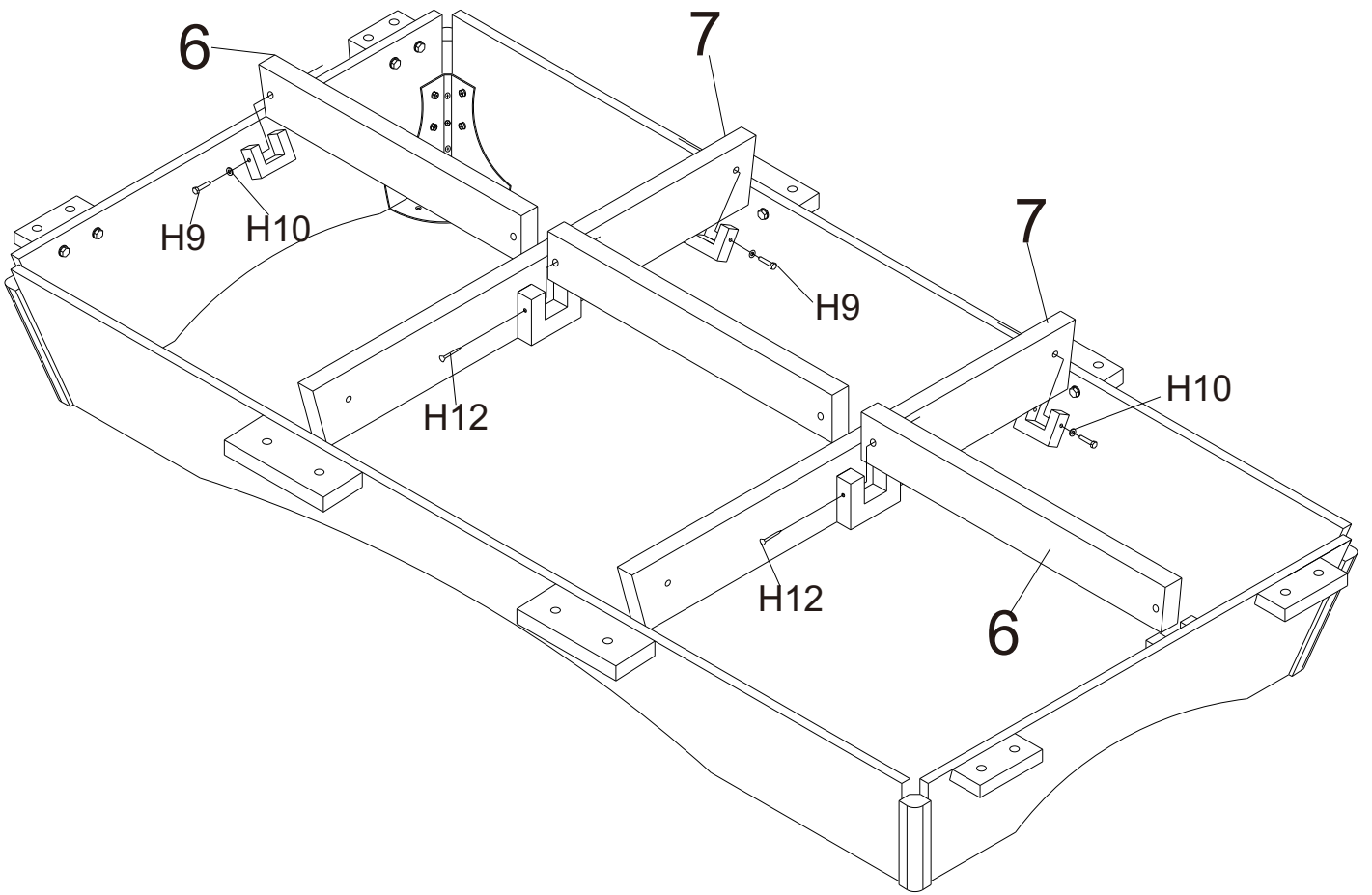


FIG.5

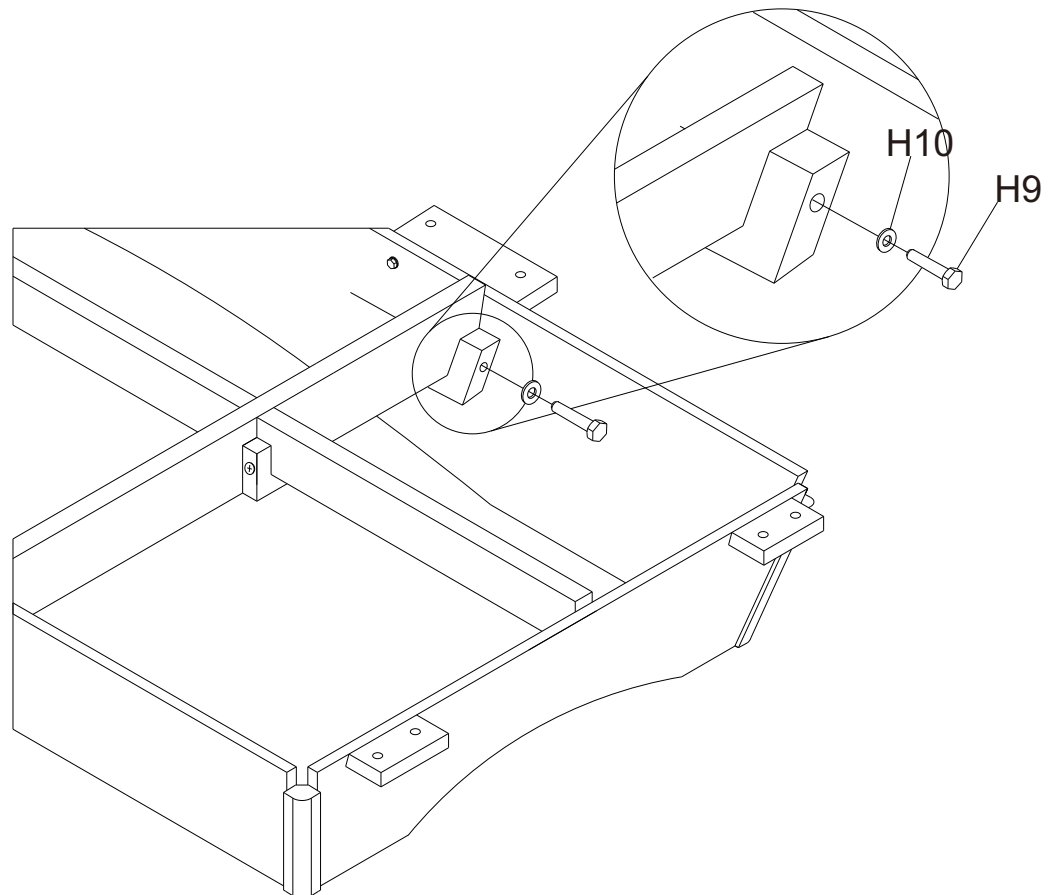


FIG.6

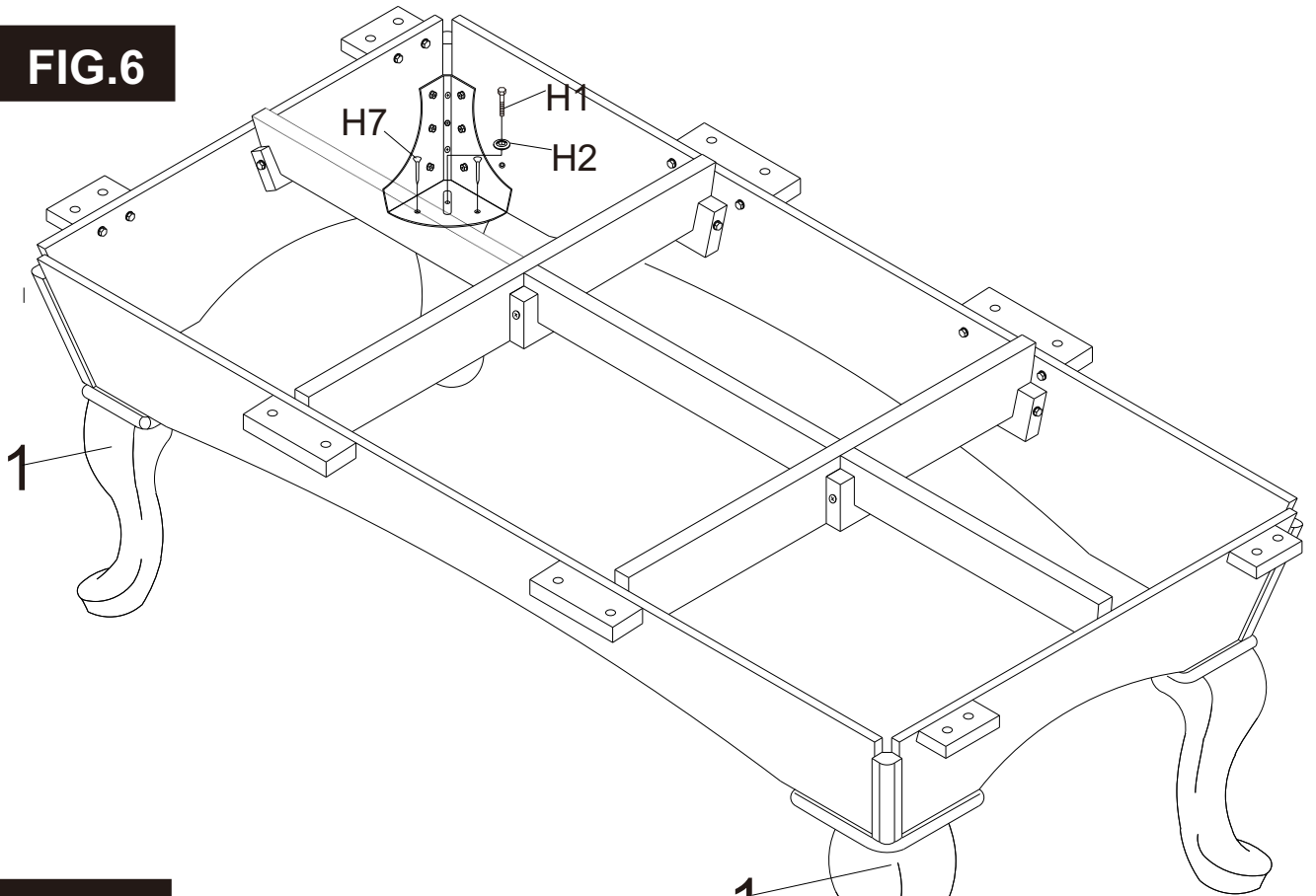


FIG.7

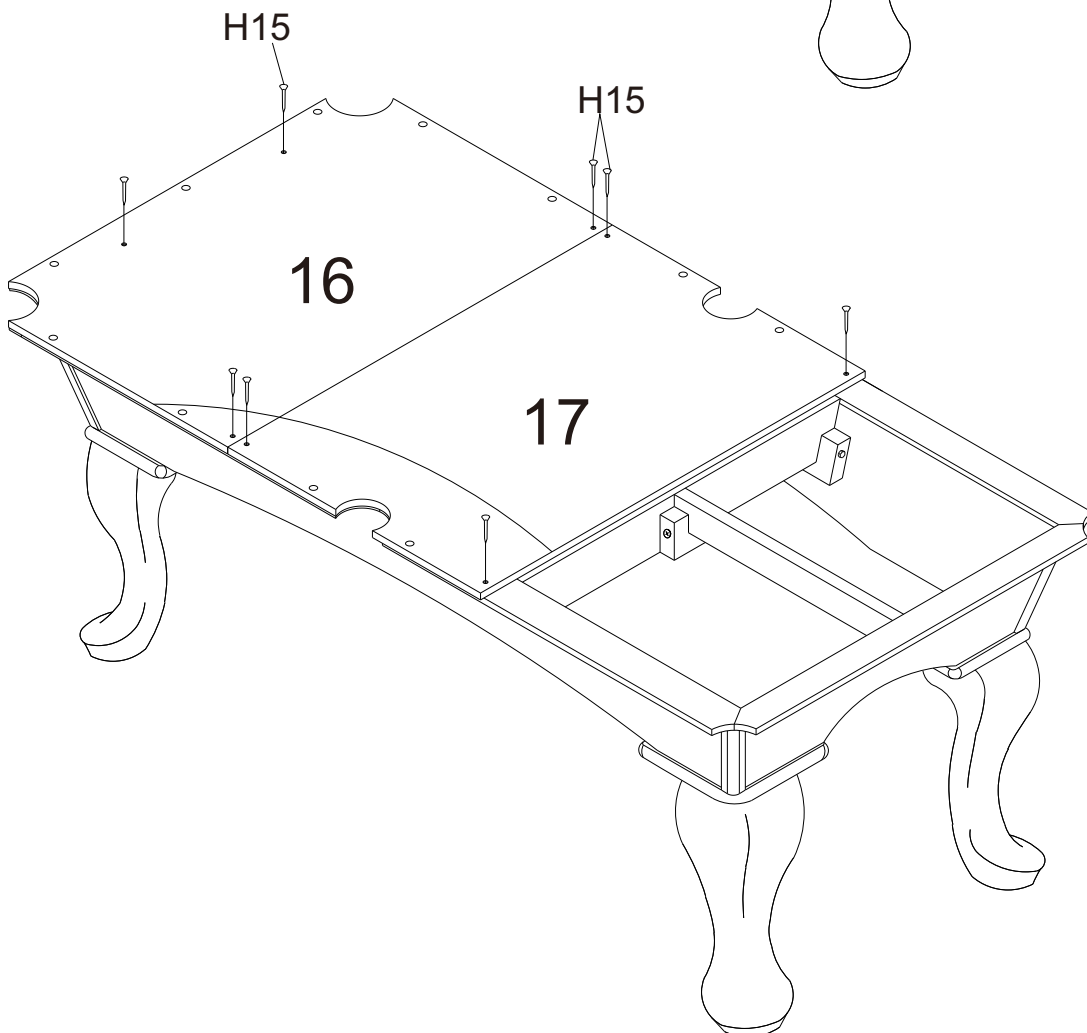


FIG.8

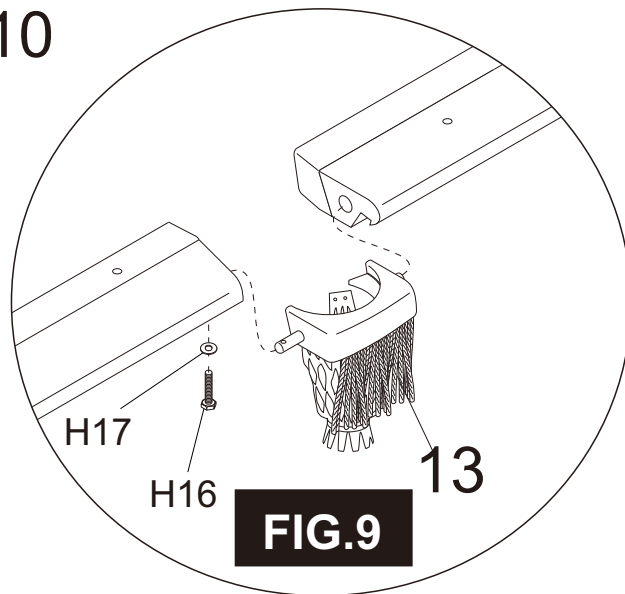
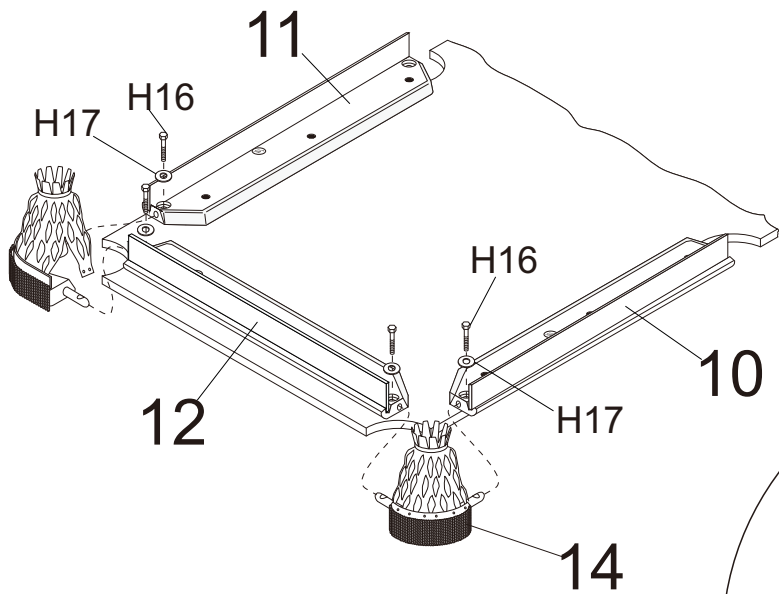


FIG.9

FIG.10

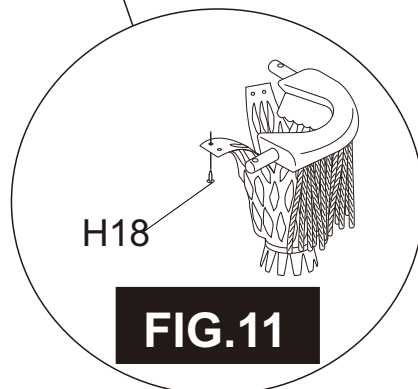
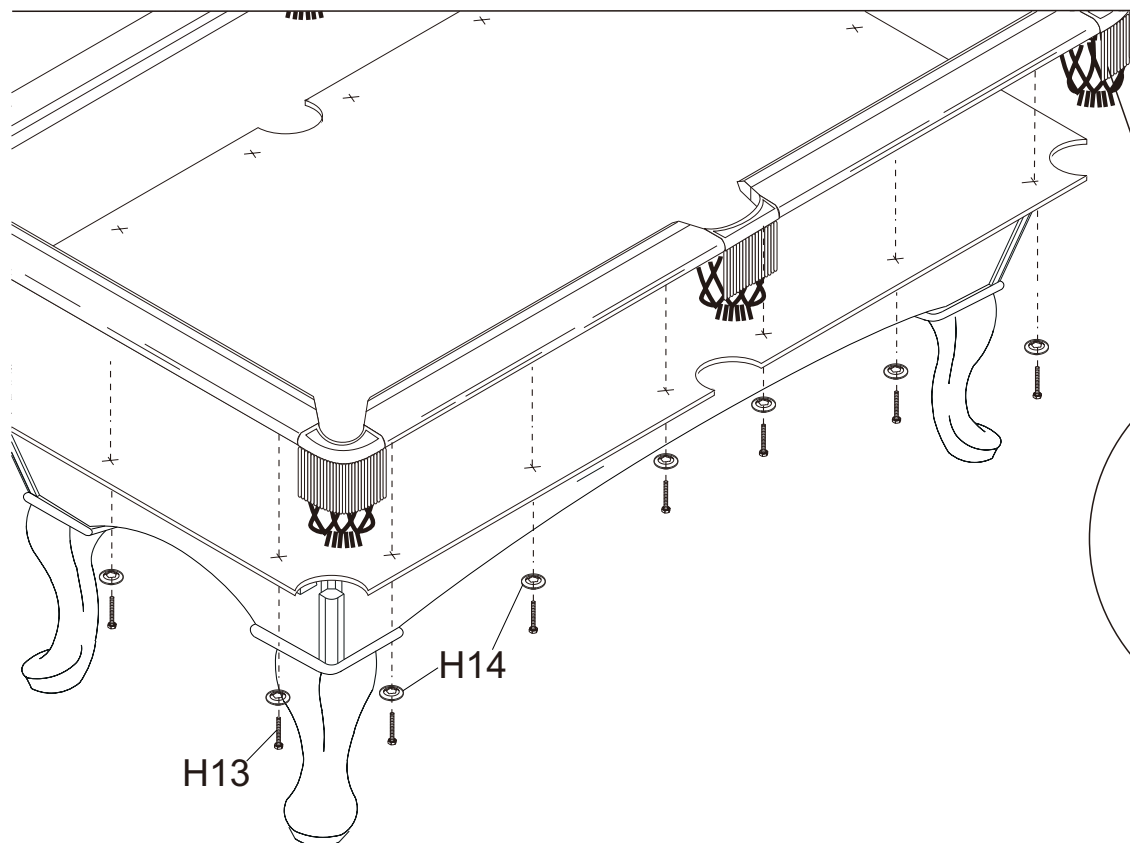


FIG.11