

INSTRUCTION MANUAL

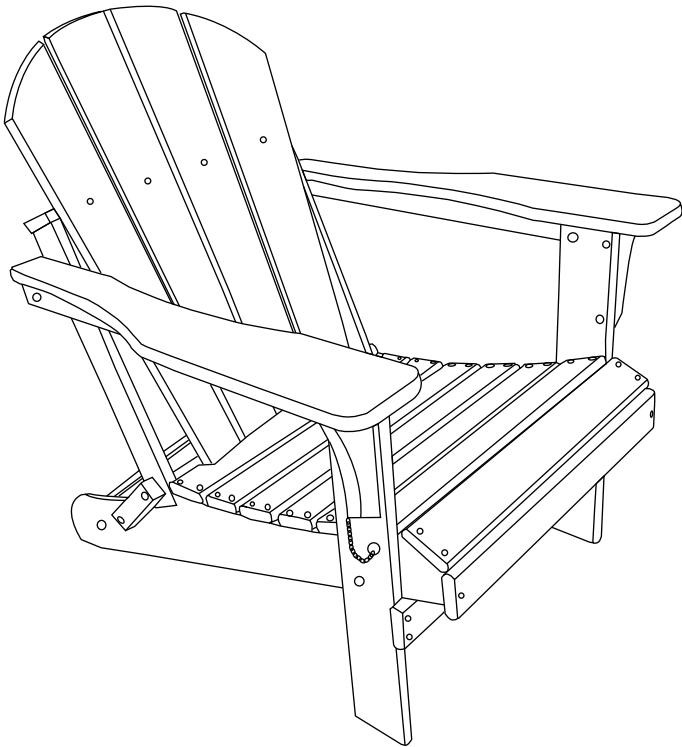

! NOTICE

Do not overtighten screws. (Insert all screws before tighten screws.)

- Please do not exceed the weight limitations of this item.
- Do not stand on or use any part of this item as a step ladder.
- Firmly secure all bolts, screws and nuts before use.
- Reconfirm that all bolts, screws, and nuts are secure every 90 days.
- Do not use or store this item in the proximity of open flame or flammable/combustible chemicals.
- Be aware that some parts are heavy and have sharp edges.
- Be very careful when folding chair to avoid smashing your hands or fingers.

TOOLS REQUIRED



ALLEN WRENCH
(PROVIDED)



WRENCH
(PROVIDED)



CHAIR
330 LBS
CAPACITY



1 PERSON
ASSEMBLY



UP TO 30 MIN.
ASSEMBLY

HARDWARE

1

M6 x80mm
BOLT

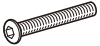

2 PCS

2

M6 x 60mm
BOLT



4 PCS

3

M6 x50mm
BOLT



4 PCS

4

M6.3 x 50mm
BOLT



2 PCS

5

M6 x 30mm
BOLT



4 PCS

6

M6 NUT



8 PCS

7

M6 WASHER



8 PCS

8

WRENCH

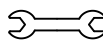

1 PC

9

ALLEN
WRENCH

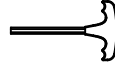

1 PC

PARTS

A

CHAIR SEAT

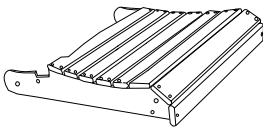

1 PC

B

RIGHT CHAIR LEG

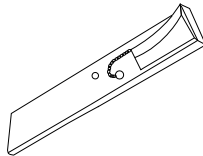

1 PC

C

LEFT CHAIR LEG

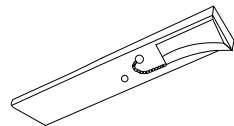

1 PC

PARTS

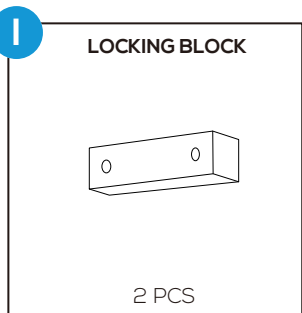
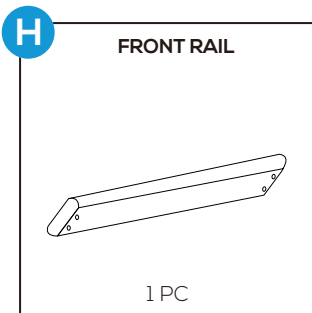
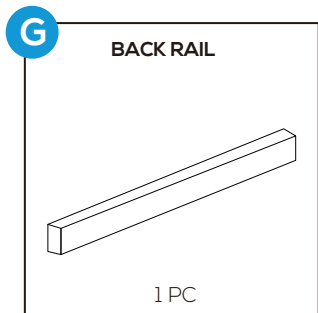
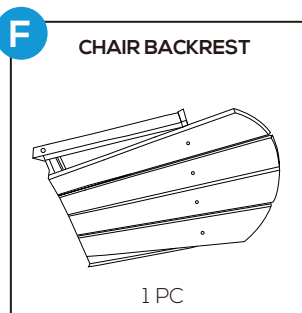
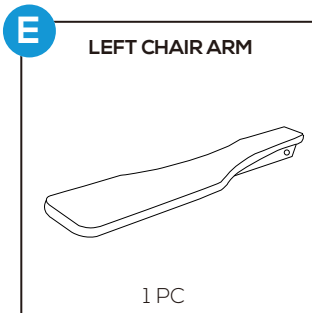
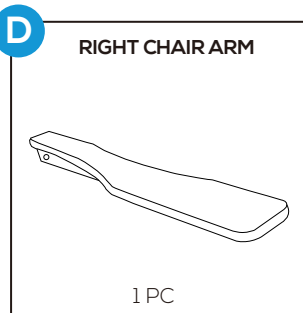

PRODUCT ASSEMBLY - OVERALL VIEW

1

Look at following overall view of this chair and learn the exact position of each parts to be assembled.

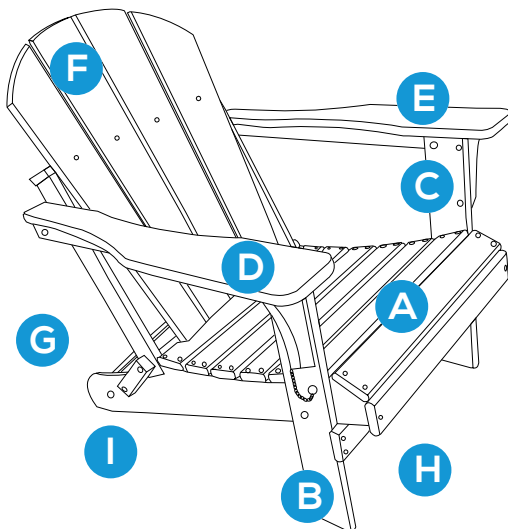

PRODUCT ASSEMBLY

1

Attach part C Left Chair Leg to part E Left Chair Arm with 1 PC of part 2 bolt and part 7 washer and part 6 Nut. Do same to part B Right Chair Leg and part D Right Chair Arm. Attach the locking stick to Chair legs with a screw driver before assembly.

Do not tighten screws too much at this stage.

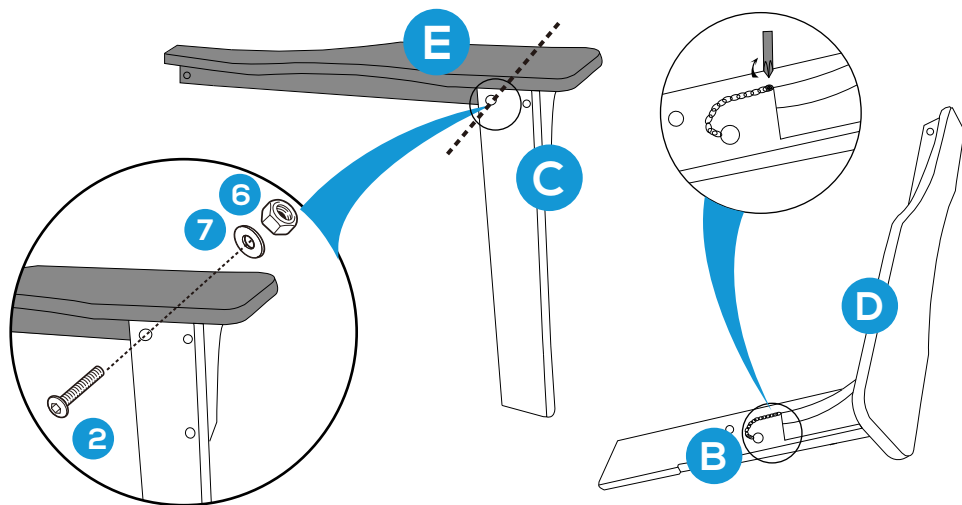

2

Attach part B right Chair Leg and part C Left Chair Leg to part A Chair Seat with 2 PCS of part 2 bolt and part 7 washer and part 6 Nut.

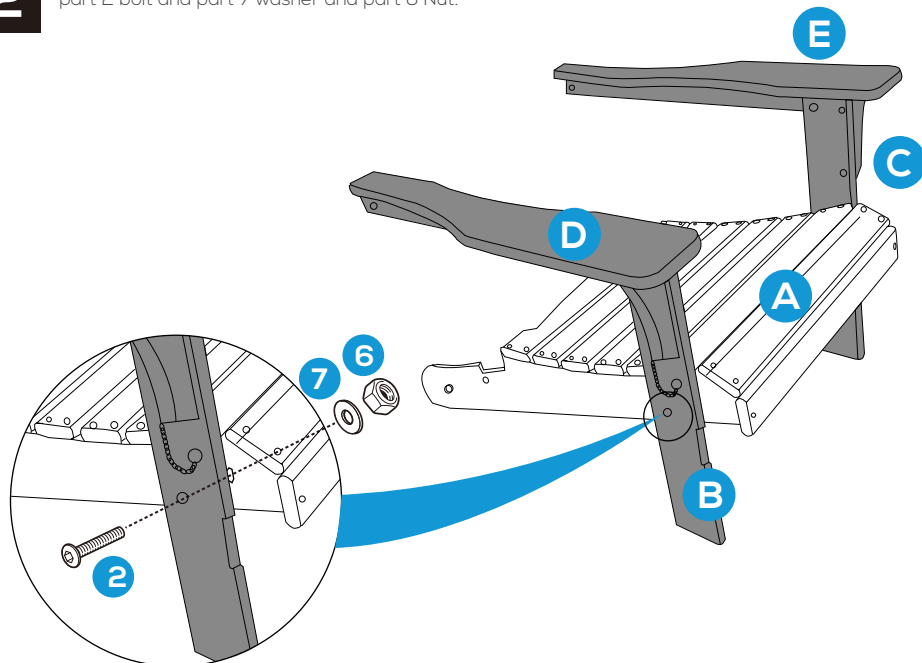

PRODUCT ASSEMBLY

3

Fix part F Backrest into part A Chair Seat and then attach part F Chair Backrest to part D Right Chair Arm with 1 PC of part 1 bolt and part 7 washer and part 6 Nut.

Do the same to attach part F Backrest to part E Left Chair Leg.

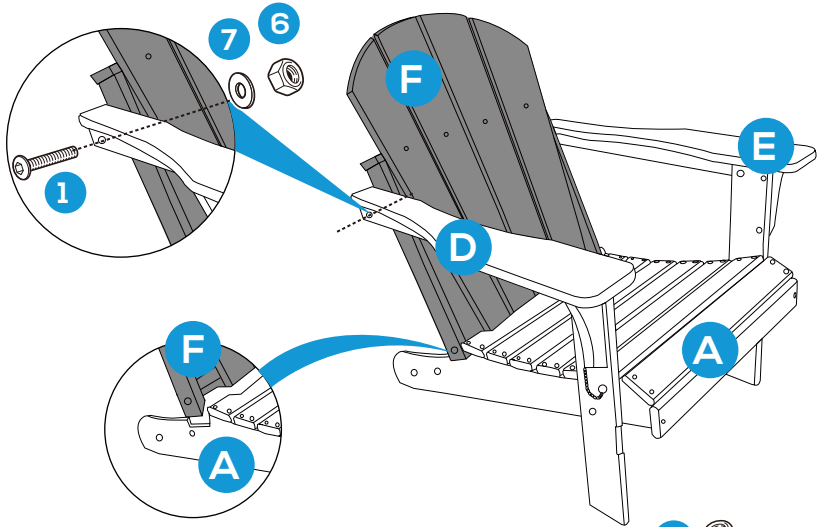

4

Attach part I Locking Blocks to part F Chair Backrest (Both sides) with 2 pcs of part 4 bolt and attach part I Locking Blocks to part A Chair seat (Both sides) with 2 PCS of part 3 bolt and part 7 washer and part 6 Nut.

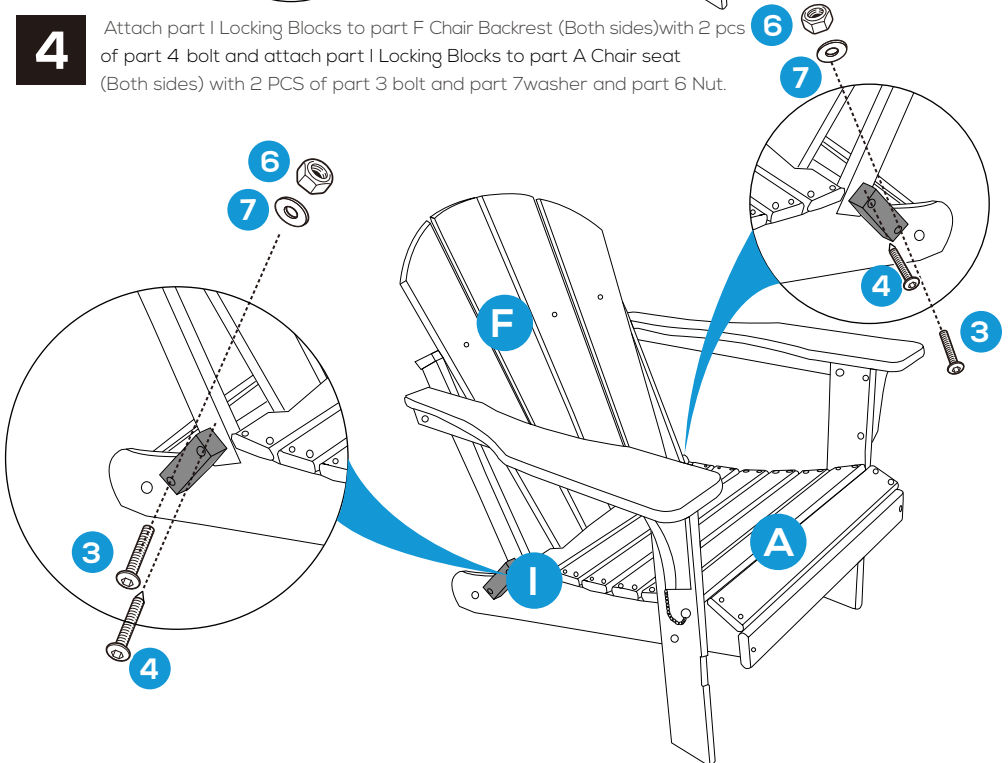

PRODUCT ASSEMBLY

5

Attach part G Back Rail to part A Chair Seat with 2 PCS of part 3 bolt

Attach part H Front Rail to Part B Left Chair leg and part C Right Chair leg with 4 PCS of part 5 bolt.

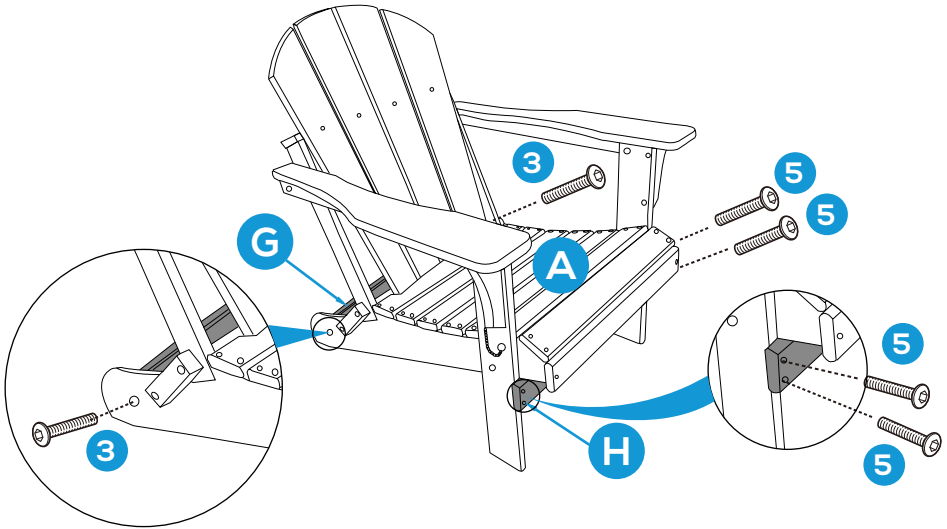

Congratulation! You finishes the assembly .

Pull the stick out of both legs to fold this chair as below.

