













CARE AND MAINTENANCE

Spot clean using a mild water-free solvent. Only a professional cleaner should undertake a complete overall cleaning.
The use of steam or water-based cleaners may cause excessive shrinking or staining.

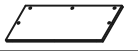
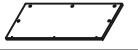
NOTICE

- * Please make sure that you have all parts indicated before you begin assembly of this item.
- * This item should be assembled on a soft surface to prevent scratching the finish during assembly.
- * This item may require periodic tightening.

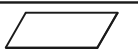



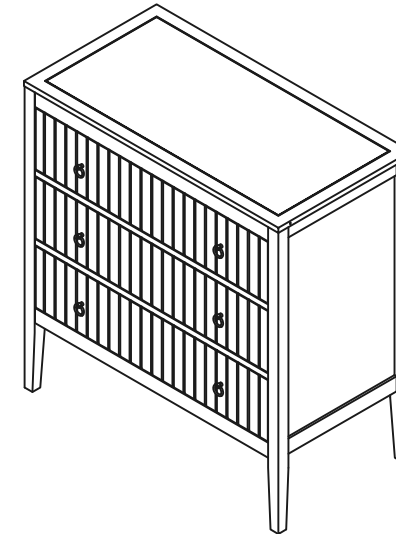

Part List and Hardware List

PIECE	DESCRIPTION	PICTURE	QUANTITY
A	TOP PANEL		1X
B	LEFT PANEL		1X
C	RIGHT PANEL		1X
D	TOP FRAME		1X
E	BOTTOM FRAME		3X
F	BOTTOM PANEL		1X
G	UPPER BACK PANEL		1X
H	LOWER BACK PANEL		1X
I	DRAWER FRONT		3X
J	DRAWER LEFT		3X
K	DRAWER RIGHT		3X
L	DRAWER BACK		3X
M	DRAWER BASE		3X
N	DRAWER SUPPORT		3X



WEIGHT CAPACITY :
TOP : 110 LBS
DRAWER : 30 LBS

**WARNING: DO NOT OVER TORQUE
BOLTS/SCREWS**

PIECE	DESCRIPTION	PICTURE	QUANTITY
1	1 1/4" FLAT HEAD SCREW	M3x32mm 	33X
2	3/4" FLAT HEAD SCREW	M3x19mm 	18X
3	CAMBOLT		29X
4	CAMLOCK		29X
5	MACHINE SCREW		6X
6	HANDLE		6X
7	WOODEN DOWEL		8X

PREPARATION

Before beginning assembly of product, make sure all parts are present. Compare parts with package contents list and hardware contents list.

If any part is missing or damaged, do not attempt to assemble the product.

Estimated Assembly Time: 60 minutes.

Tools Required for Assembly : Phillips Screwdriver

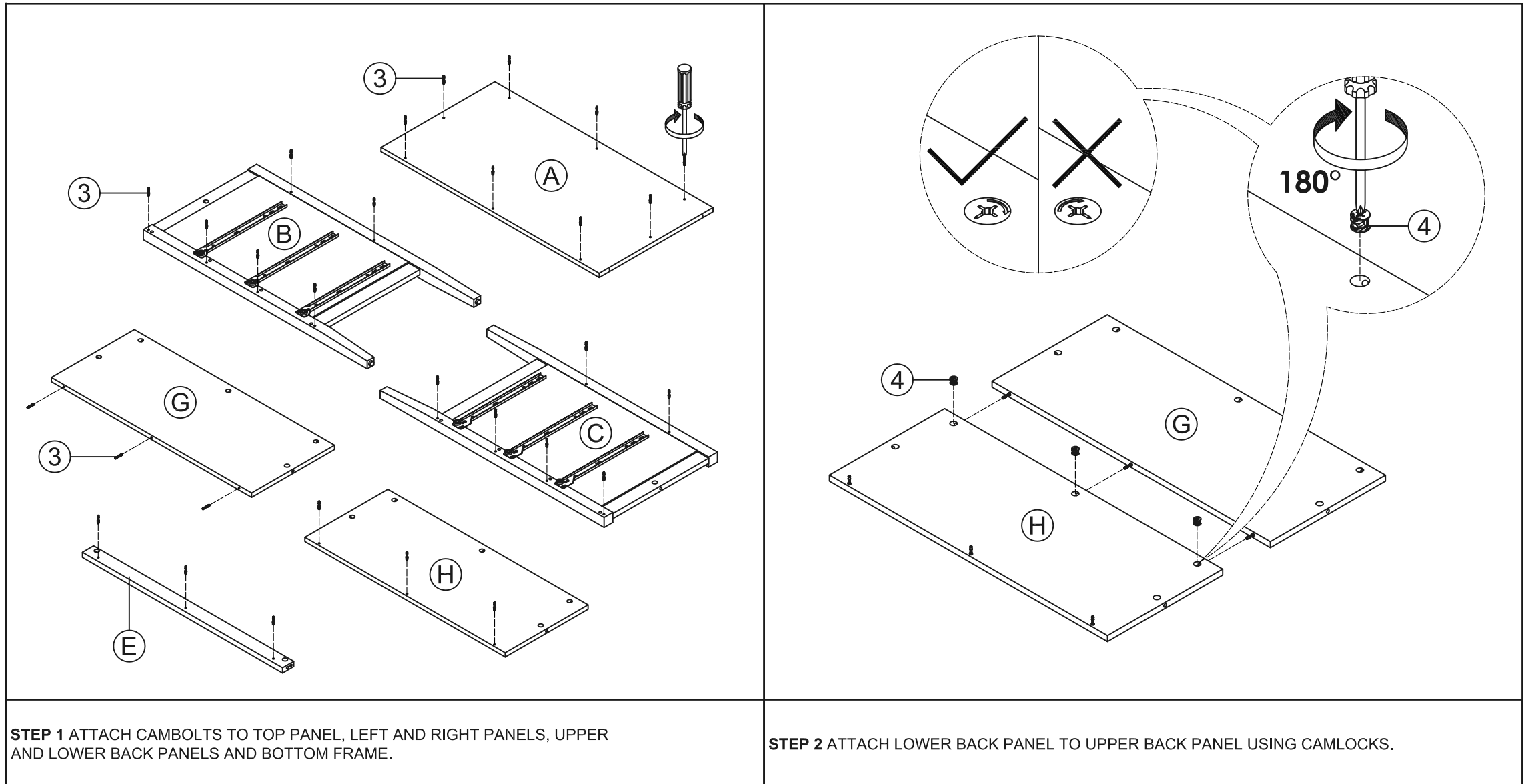

PREPARATION

Before beginning assembly of product, make sure all parts are present. Compare parts with package contents list and hardware contents list.

If any part is missing or damaged, do not attempt to assemble the product.

Estimated Assembly Time: 60 minutes.

Tools Required for Assembly : Phillips Screwdriver

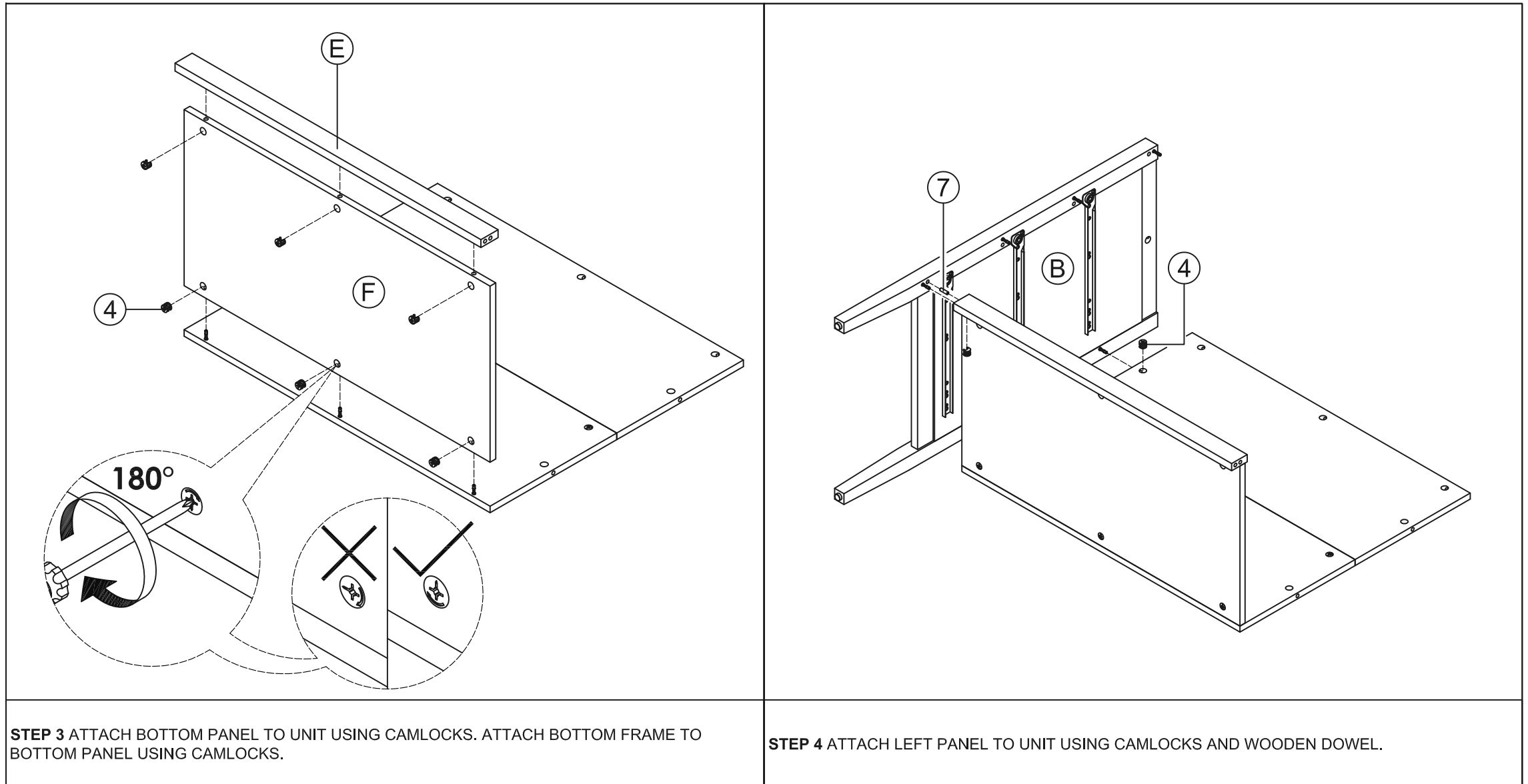

PREPARATION

Before beginning assembly of product, make sure all parts are present. Compare parts with package contents list and hardware contents list.

If any part is missing or damaged, do not attempt to assemble the product.

Estimated Assembly Time: 60 minutes.

Tools Required for Assembly : Phillips Screwdriver

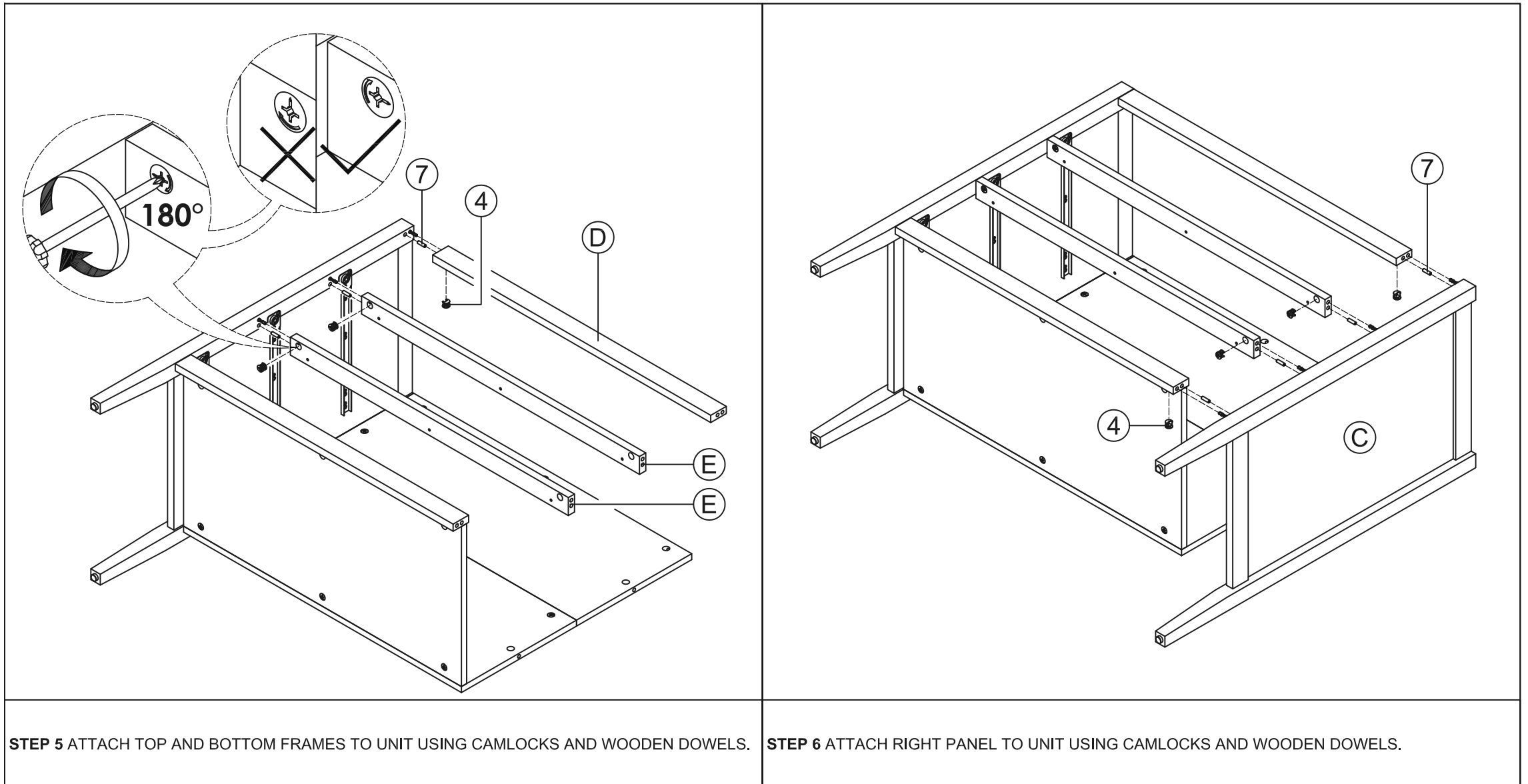

PREPARATION

Before beginning assembly of product, make sure all parts are present. Compare parts with package contents list and hardware contents list.

If any part is missing or damaged, do not attempt to assemble the product.

Estimated Assembly Time: 60 minutes.

Tools Required for Assembly : Phillips Screwdriver

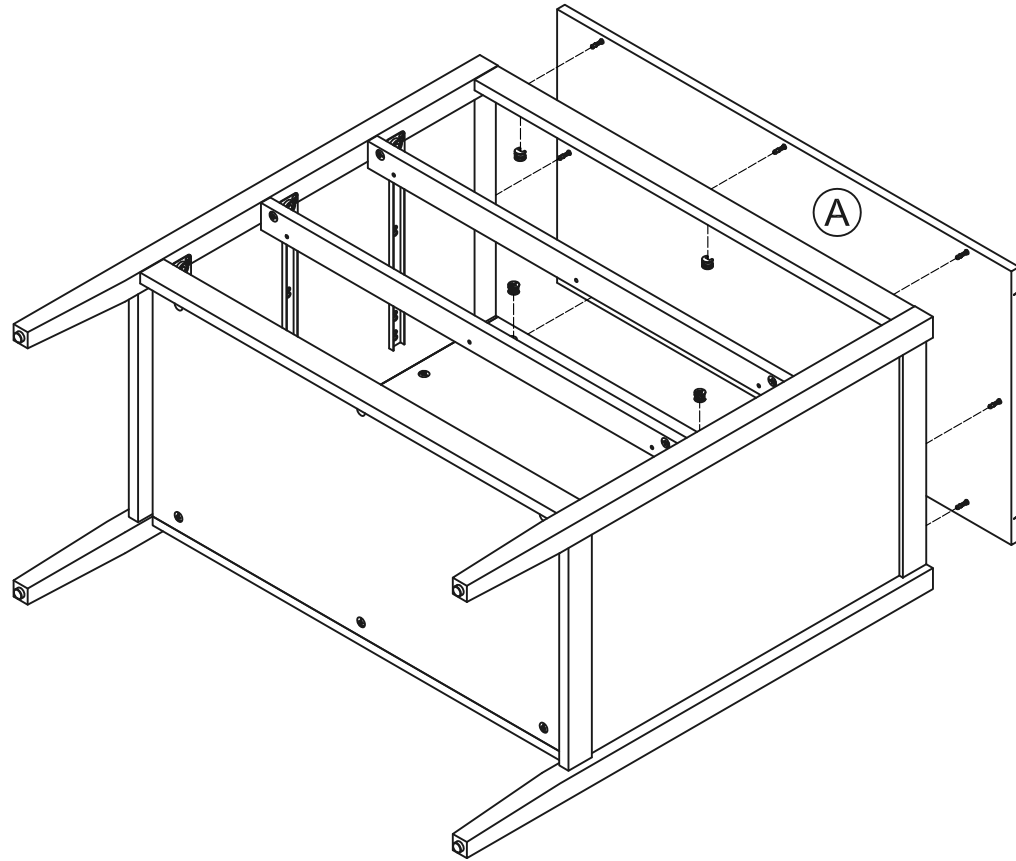

STEP 7 ATTACH TOP PANEL TO UNIT USING CAMLOCKS.

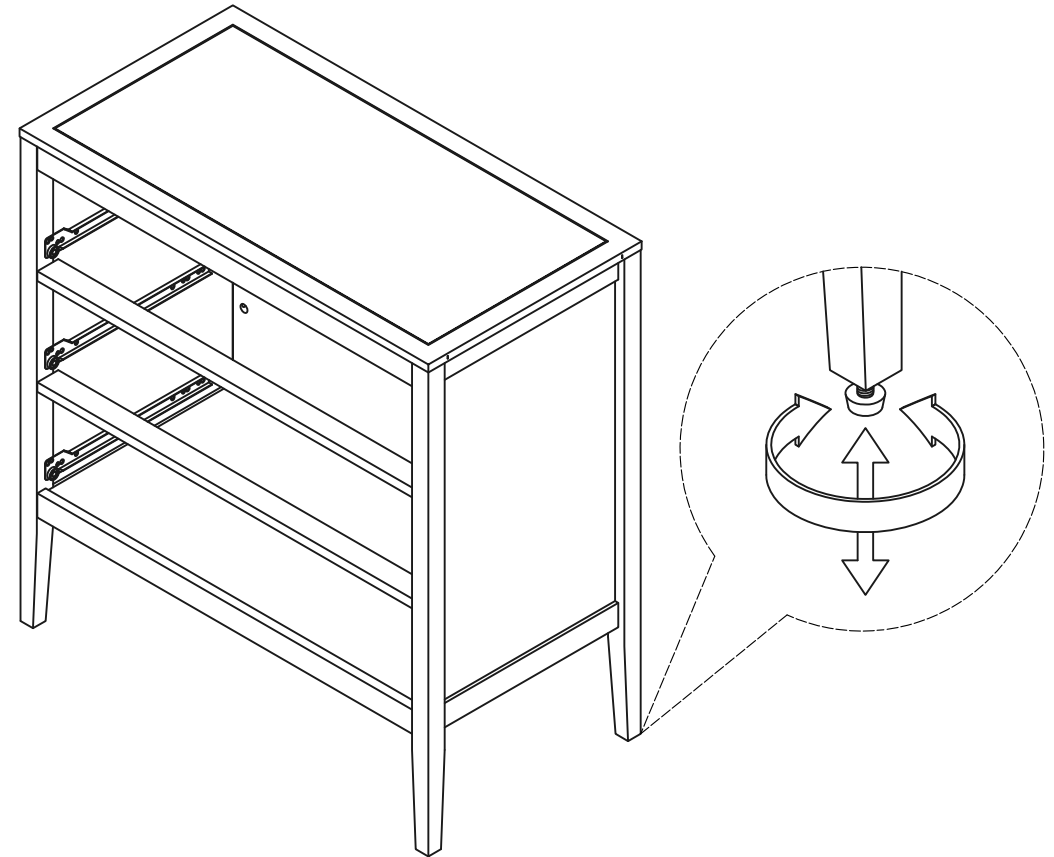

STEP 8 ADJUST THE ADJUSTER THAT HAS ALREADY BEEN ASSEMBLED TO THE LEGS TO STABILIZE YOUR UNIT.

PREPARATION

Before beginning assembly of product, make sure all parts are present. Compare parts with package contents list and hardware contents list.

If any part is missing or damaged, do not attempt to assemble the product.

Estimated Assembly Time: 60 minutes.

Tools Required for Assembly : Phillips Screwdriver

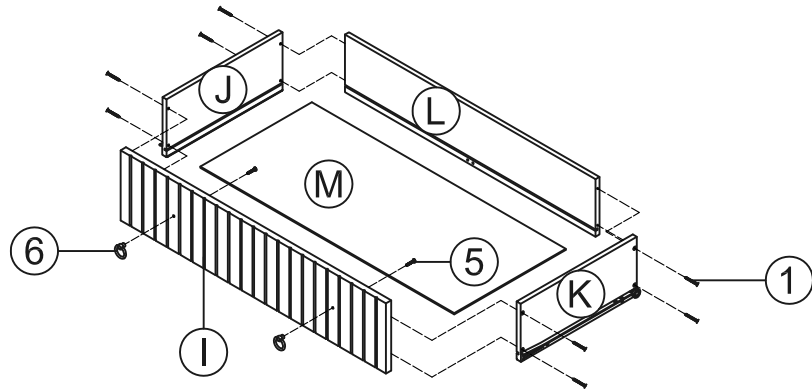

STEP 9 ATTACH HANDLE TO DRAWER FRONT USING MACHINE SCREWS.
ATTACH DRAWER LEFT AND RIGHT TO DRAWER BACK USING 1 1/4" FLAT HEAD SCREWS.
SLIDE DRAWER BASE INTO THE GROOVE.
ATTACH DRAWER FRONT TO DRAWER LEFT AND RIGHT USING 1 1/4" FLAT HEAD SCREWS.

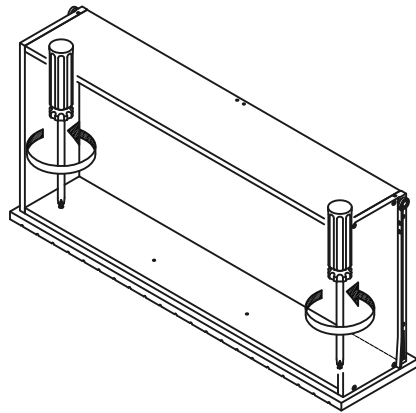

STEP 11 LOOSEN SLIGHTLY THE SCREWS PRE-INSTALLED ON THE BACK OF THE DRAWER FRONTS.

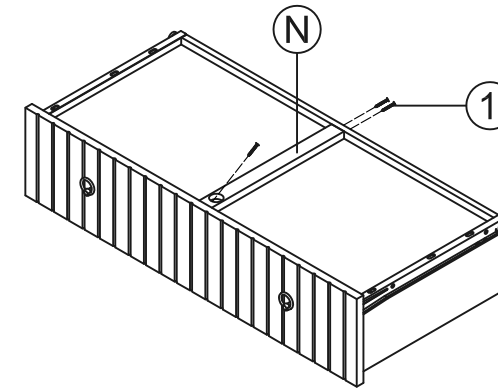

STEP 10 ATTACH DRAWER SUPPORTS TO THE BOTTOM SIDE OF DRAWERS USING 1 1/4" FLAT HEAD SCREWS.

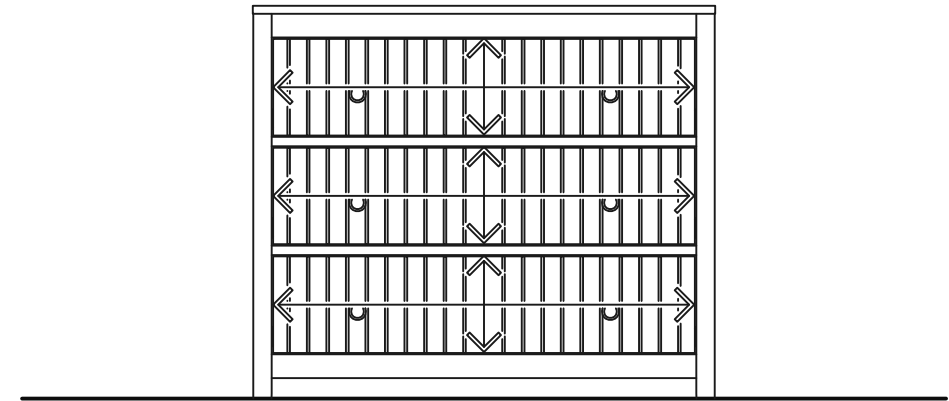

STEP 12 INSERT THE DRAWER INTO THE UNIT, THEN ADJUST THE DRAWER FRONT PANEL LEFT OR RIGHT AND UP OR DOWN UNTIL THE DRAWER GAPS LOOK PROPORTIONAL.

PREPARATION

Before beginning assembly of product, make sure all parts are present. Compare parts with package contents list and hardware contents list.

If any part is missing or damaged, do not attempt to assemble the product.

Estimated Assembly Time: 60 minutes.

Tools Required for Assembly : Phillips Screwdriver

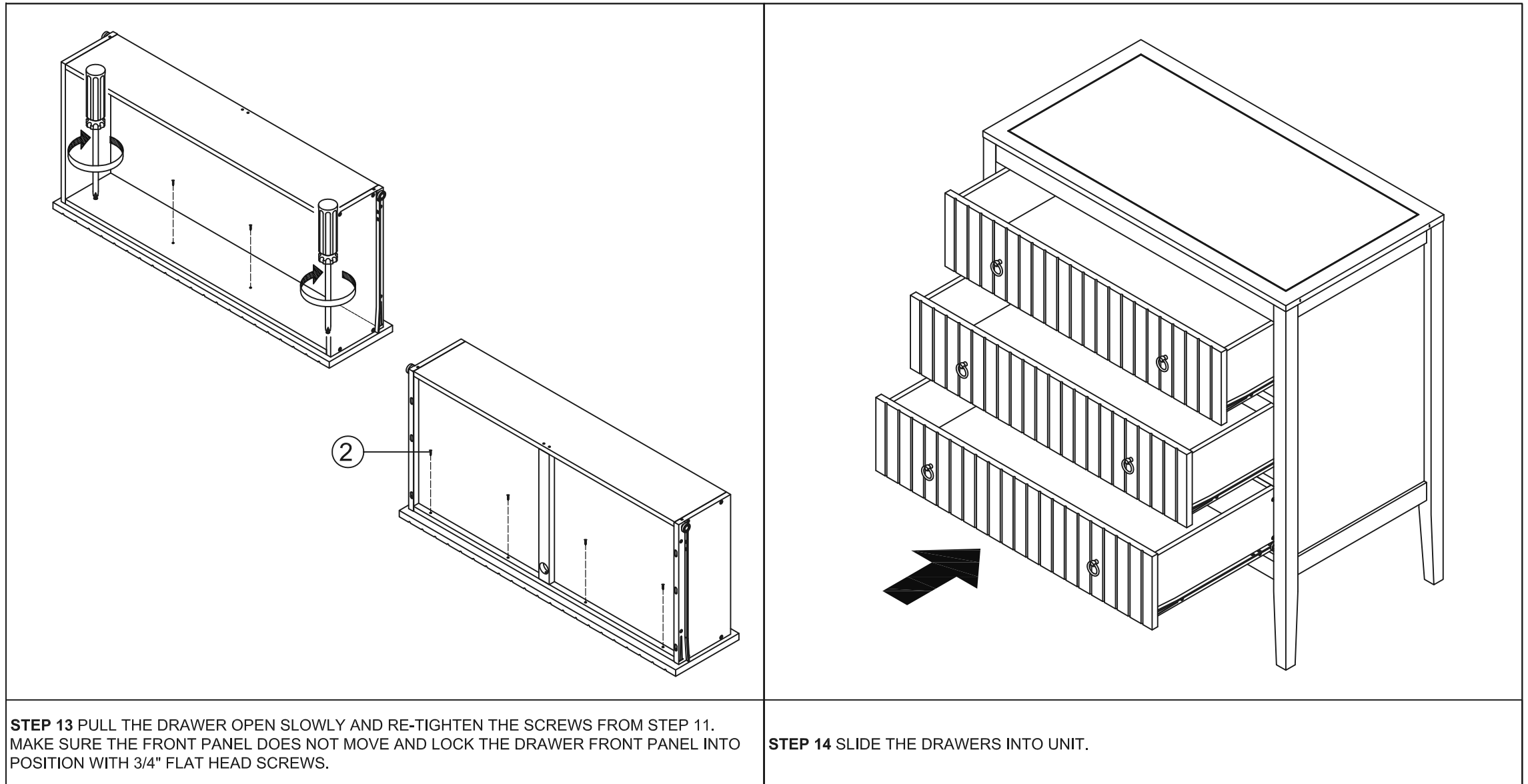

STEP 13 PULL THE DRAWER OPEN SLOWLY AND RE-TIGHTEN THE SCREWS FROM STEP 11. MAKE SURE THE FRONT PANEL DOES NOT MOVE AND LOCK THE DRAWER FRONT PANEL INTO POSITION WITH 3/4" FLAT HEAD SCREWS.

STEP 14 SLIDE THE DRAWERS INTO UNIT.