

# HEADBOARD AND FOOTBOARD SET ASSEMBLY INSTRUCTION (TOTAL 1 BOX)

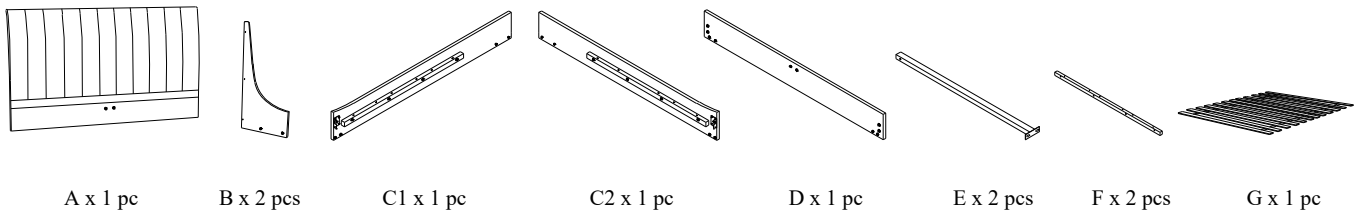

A x 1 pc

B x 2 pcs

C1 x 1 pc

C2 x 1 pc

D x 1 pc

E x 2 pcs

F x 2 pcs

G x 1 pc

Please read over the instructions, it will be a time-saver in the long run.

Note: Before assembly, please be sure to work on a soft flat surface to avoid any damage to the finish.

Please leave bolts loosened until all bolts are placed before tightening completely.

Part#	Picture	Description	QTY	Location	Part#	Picture	Description	QTY	Location
H		Center leg	1	Wrapped in a non-woven bag	S		Spring Washer Ø8	18	Hardware Pack
I		"L" connection piece	2	Wrapped in a non-woven bag				28	Already in Place
J		Triangle connection piece	2	Wrapped in a non-woven bag	T		Flat Washer Ø8x25mm	18	Hardware Pack
K		Legs	4	Spare Parts caton box				28	Already in Place
L		Screws 4x30mm	24	Hardware Pack	U		Spring Washer Ø10	2	Hardware Pack
M		Bolt Ø8x20mm	12	Already in Place	V		Flat Washer Ø10x25mm	2	Hardware Pack
N		Bolt Ø8x30mm	16	Already in Place	W		Nut Ø8	2	Hardware Pack
O		Bolt Ø8x40mm	6	Hardware Pack	X		Nut Ø10	2	Hardware Pack
P		Bolt Ø8x50mm	8	Hardware Pack	Y		Spanner Ø14	1	Hardware Pack
Q		Bolt Ø8x70mm	2	Hardware Pack	Z		Spanner Ø17	1	Hardware Pack
R		"L" Wrenches Ø5	1	Hardware Pack					

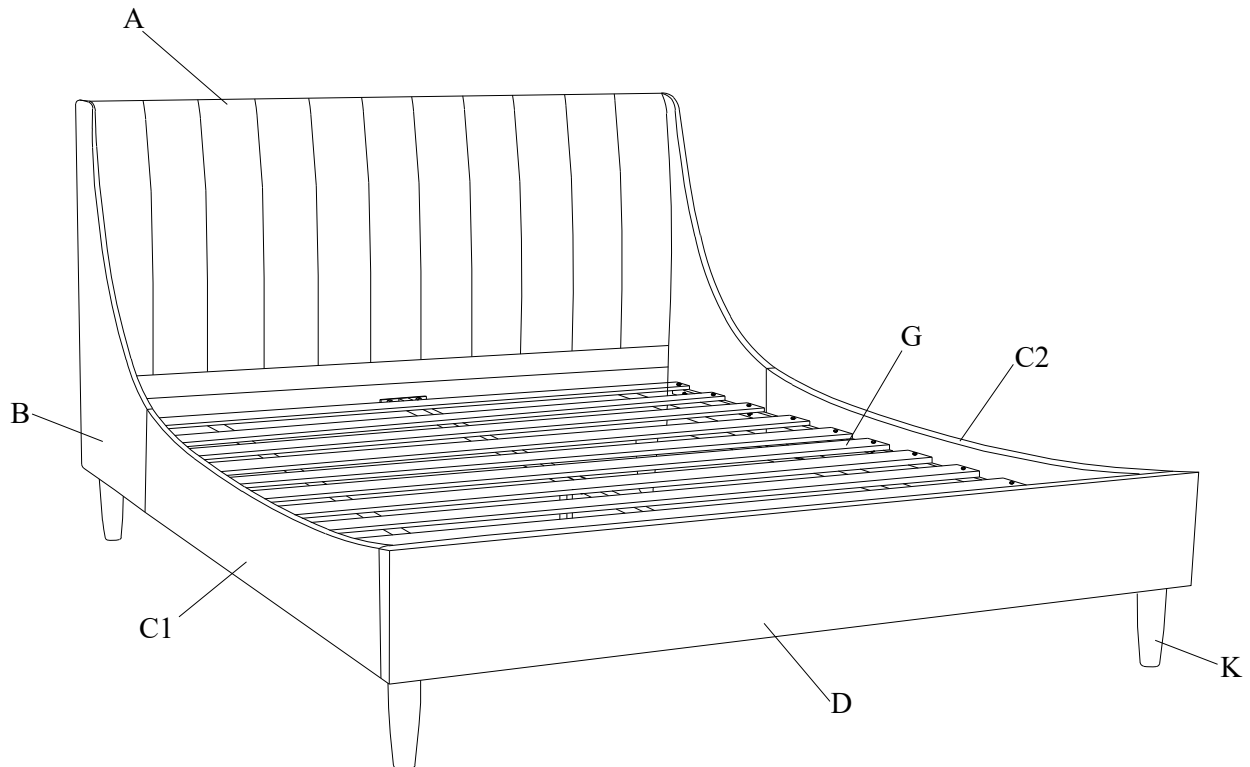

1

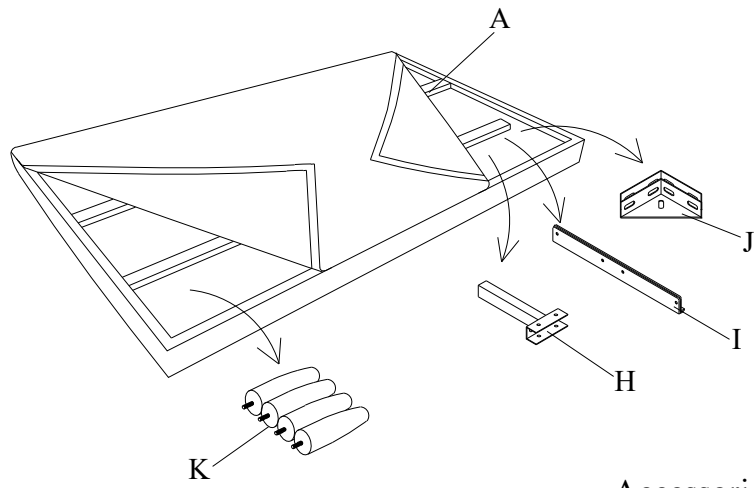

Accessories and legs are inside the back of the headboard

2

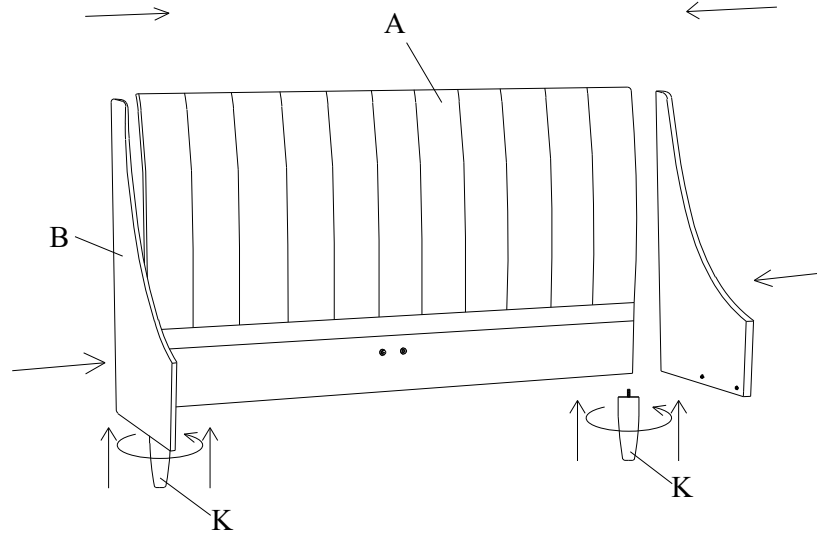

3

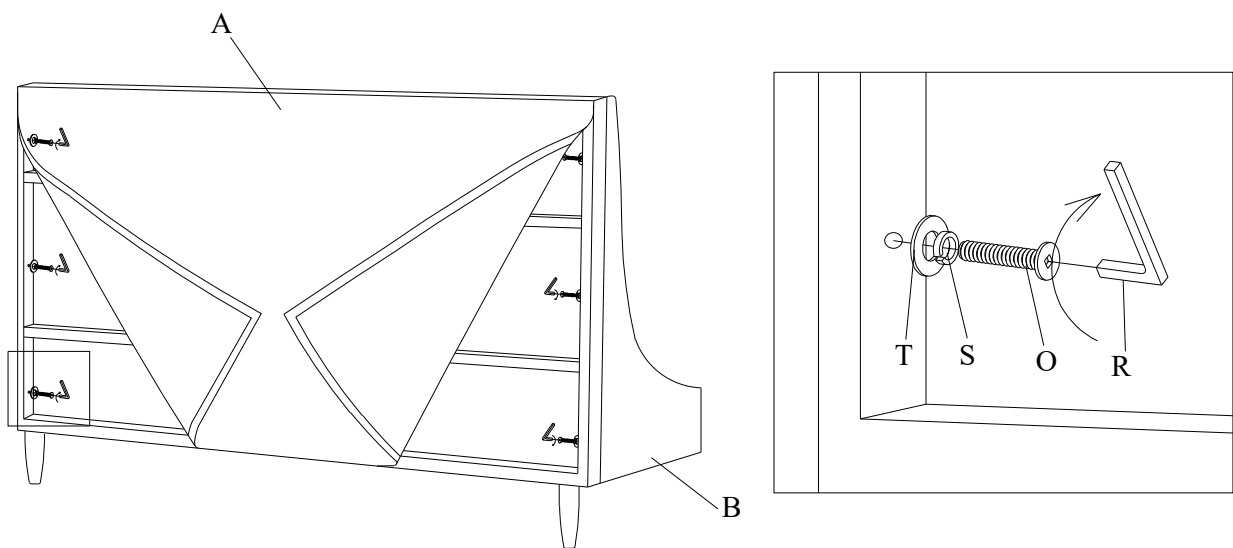

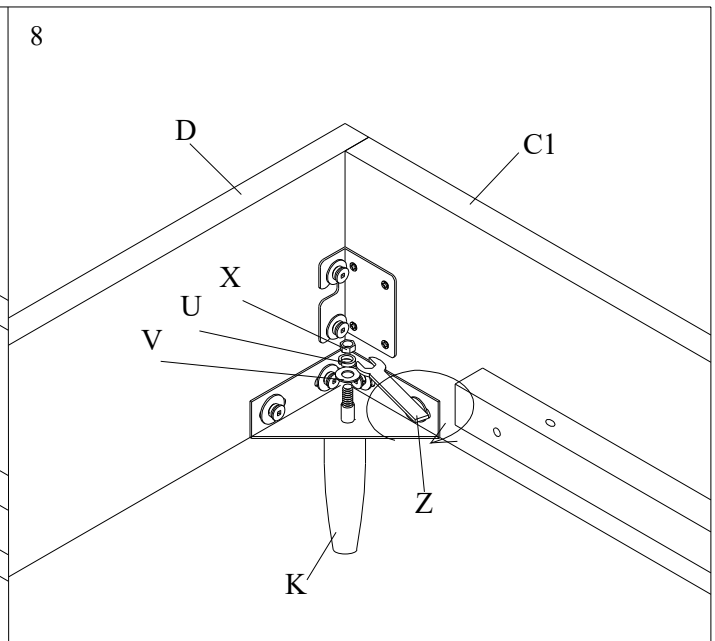
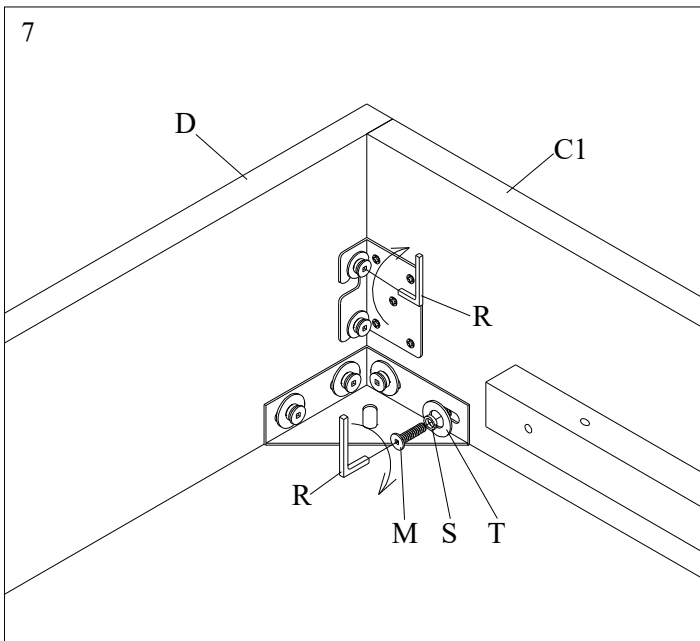
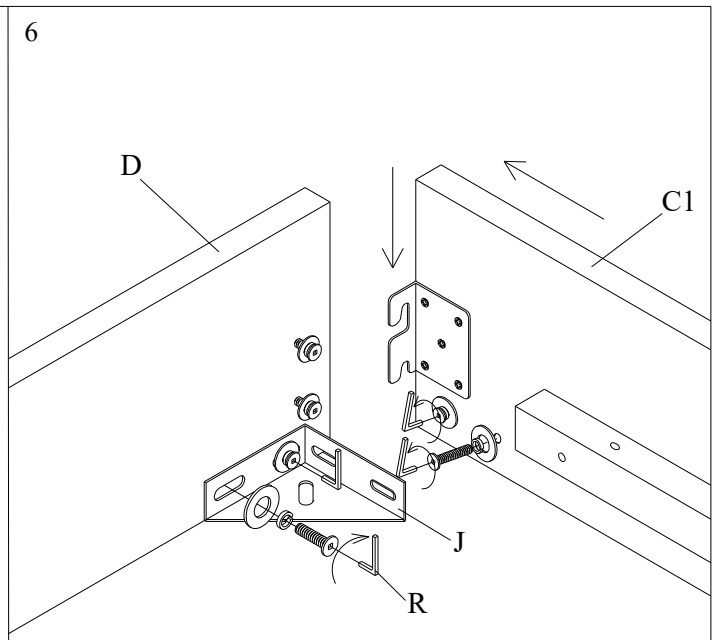
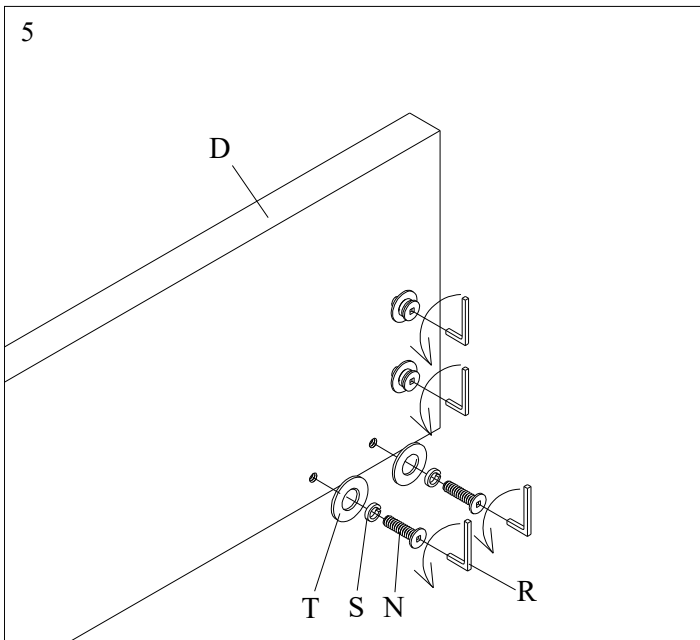
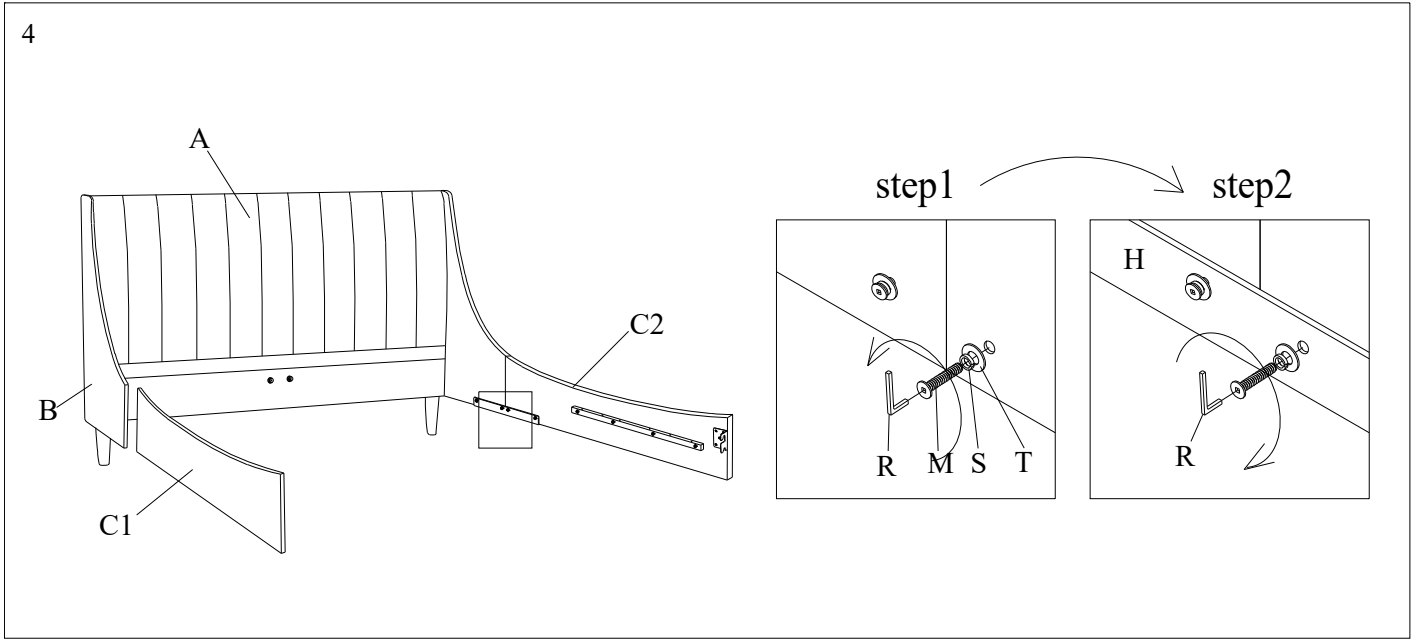

9

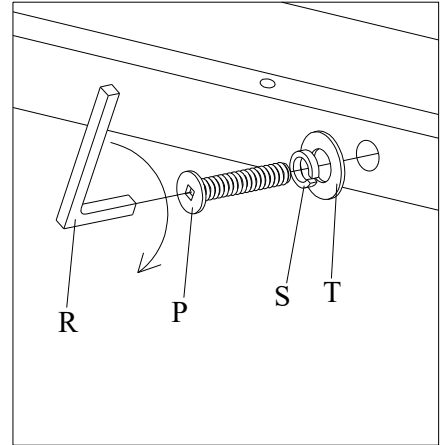
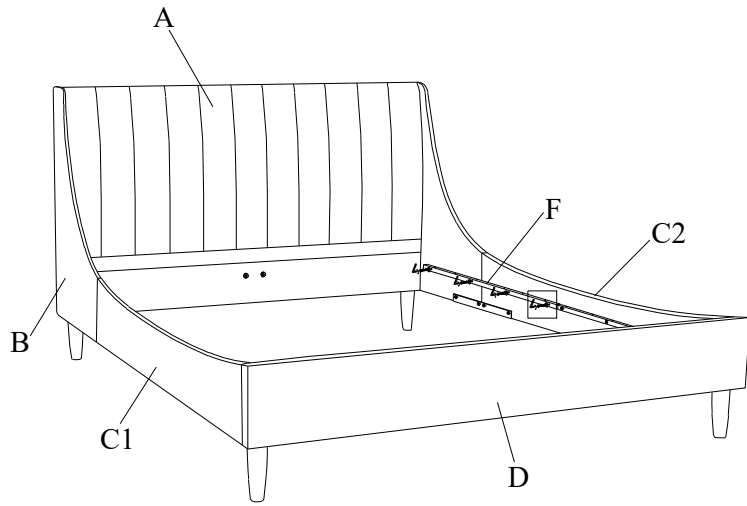

10

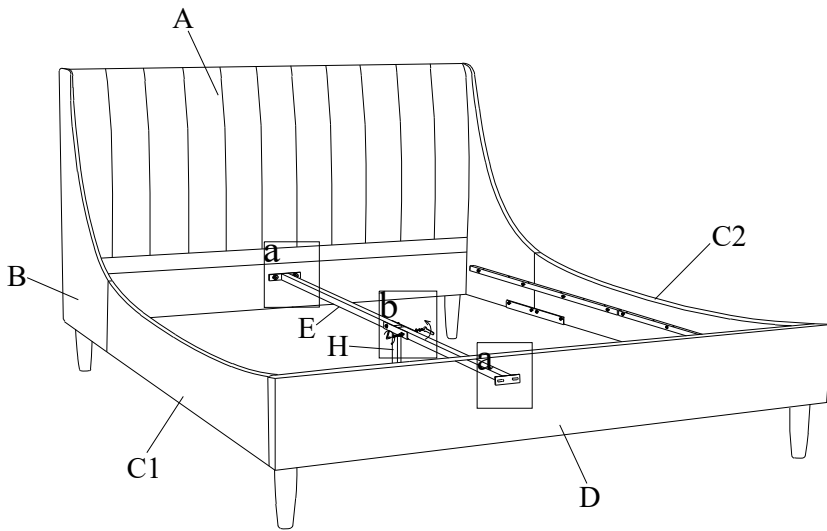

step1 → step2

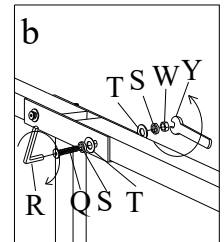
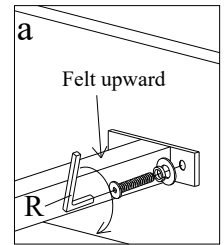
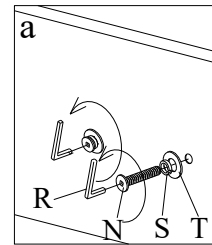

11

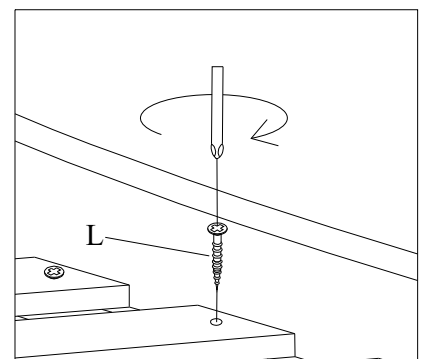
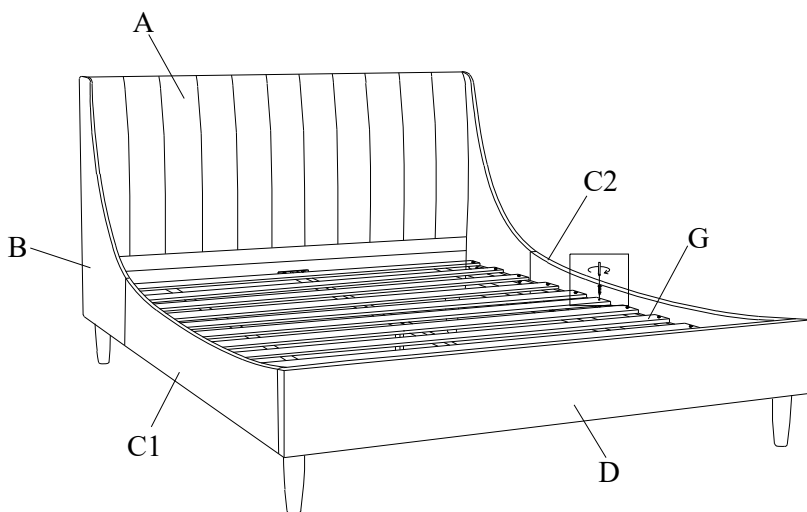

Screwdriver required, not included