

# 8' RUSTIC BILLIARDS TABLE ASSEMBLY INSTRUCTIONS











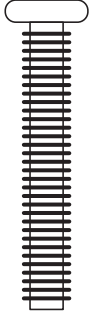

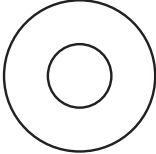
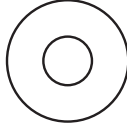
## Important!

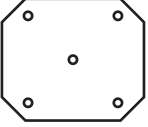
Before starting assembly, please read through this instruction book to familiarize yourself with all the parts and assembly steps. Four person adult assembly is required. Seek professional installation if unable to do so yourself. Please refer to the parts list below and be sure that all parts have been included.

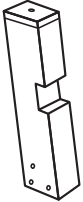
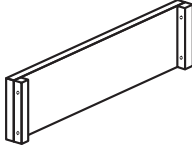
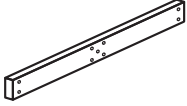
VIDEO INSTRUCTIONS  
(SCAN WITH PHONE  
CAMERA TO WATCH)

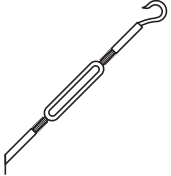
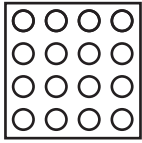

## Parts Included:

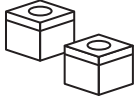
<p><b>A</b> 8mm x 50mm BOLT <b>x12</b></p>  <p><i>*true to size</i></p>	<p><b>B</b> 6.3mm x 38mm BOLT <b>x16</b></p>  <p><i>*true to size</i></p>	<p><b>C</b> 6.3mm x 50mm BOLT <b>x10</b></p>  <p><i>*true to size</i></p>	<p><b>D</b> 8mm WASHER <b>x12</b></p>  <p><i>*true to size</i></p>	<p><b>E</b> 6.3mm WASHER <b>x36</b></p>  <p><i>*true to size</i></p>	<p><b>F</b> 6.3mm LOCK NUT <b>x10</b></p>  <p><i>*true to size</i></p>
<p><b>G</b> FIXED PLATE <b>x4</b></p> 	<p><b>H</b> TOOL <b>x2</b></p> 	<p><b>I</b> LEG <b>x4</b></p> 	<p><b>J</b> WIDE LEG PANEL <b>x2</b></p> 	<p><b>K</b> SKINNY LEG PANEL <b>x2</b></p> 	<p><b>L</b> LEG LEVELER <b>x4</b></p> 
<p><b>M</b> TIE ROD <b>x2</b></p> 	<p><b>N</b> BILLIARD BALLS SET <b>x1</b></p> 	<p><b>O</b> CUE STICK <b>x2</b></p> 	<p><b>P</b> BALL RACK <b>x1</b></p> 	<p><b>Q</b> BRUSH <b>x1</b></p> 	<p><b>R</b> CUE CHALK <b>x2</b></p> 

## Assembly Instructions:

Use the included Allen Wrench (H) to assemble.  
**Warning - Assembly requires 4 or more able-bodied adults capable of lifting more than 250lbs**

**Recommended Minimum Room Size: 13.6 ft x 17 ft. Smaller rooms are possible but it will affect gameplay. For indoor use only.**

- Open the box in an open indoor space near where you will play. Remove all the contents and verify that you have all the listed parts. Position the table felt side down on a padded surface (carpet, the box, towels, etc.)

- Attach the 4 legs (I) to the table using three 8mm x 50mm bolts (A) and three 8mm washers (D) per leg. Make sure all holes are properly aligned on the bottom.

**Leg Orientation:** The legs should angle outwards as pictured. Align the three holes on the legs to the holes on the frame as shown.

- Attach the Wide Leg Panel (J) between the legs as pictured using four 6.3mm x 38mm bolts (B) and four 6.3mm washers (E). Repeat on Opposite Side.

- Attach the Leg Levelers (L) into the bottom of each leg. They will be adjusted at the end to level the playing surface.

- Attach the Skinny Leg Panel (K) across the legs as pictured using four 6.3mm x 50mm bolts (C) and four 6.3mm washers (E). Repeat on Opposite Side.

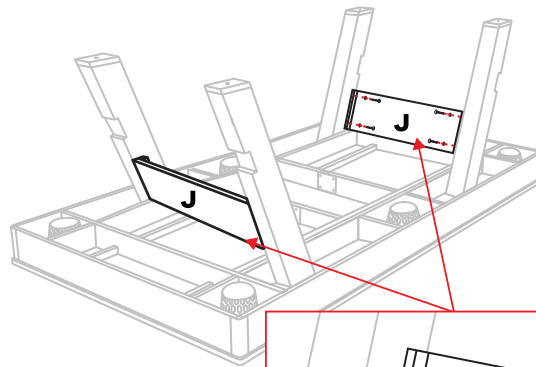
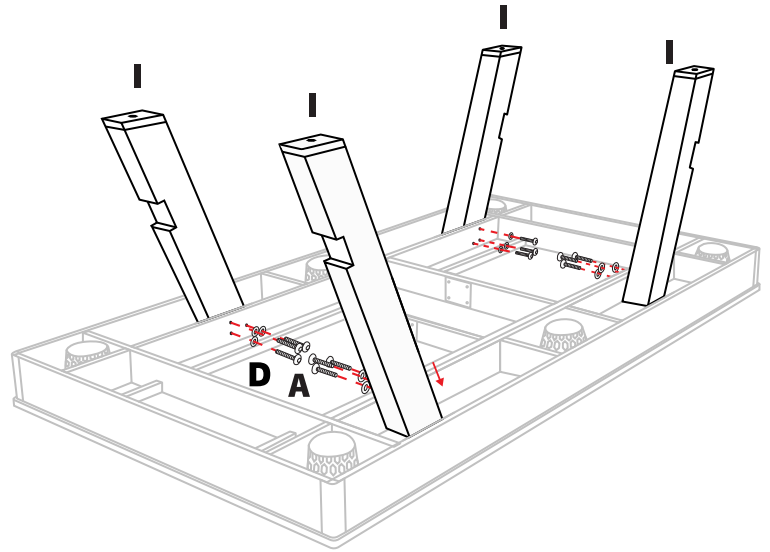

**REPEAT ON OTHER SIDE**

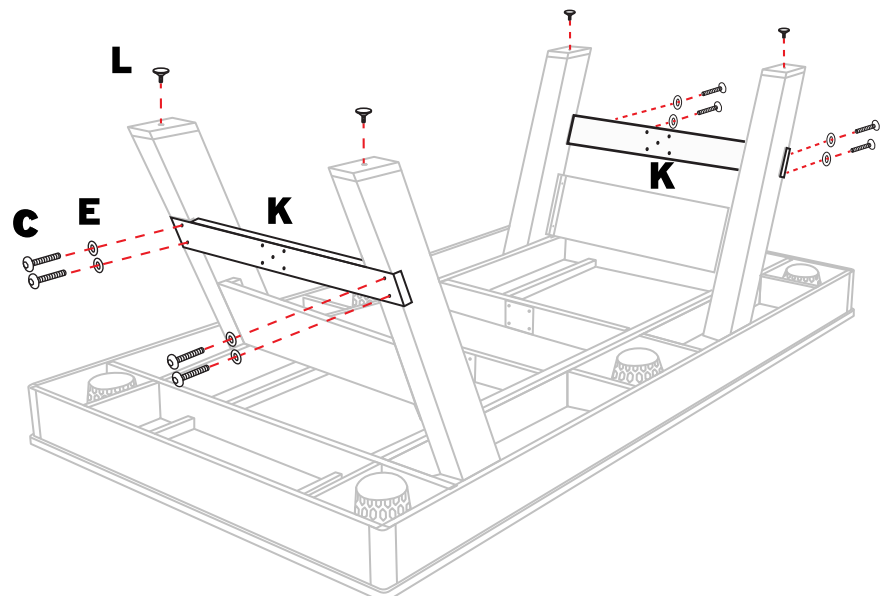
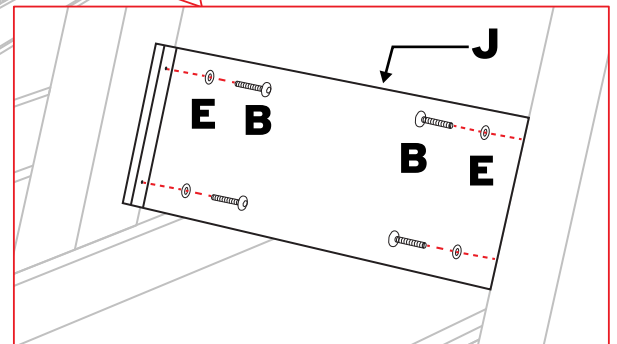

- Attach two *fixed plates (G)* to each side of Skinny Leg Panel using four 6.3mm x 38mm *bolts (B)* with four 6.3mm *washers (E)* on the exterior side and four 6.3mm *washers (E)* and four 6.3mm *lock nuts (F)* on the interior side. Bolts should be inserted in the 4 outer holes. Repeat on the opposite Skinny Leg Panel.

**REPEAT ON OTHER SIDE**

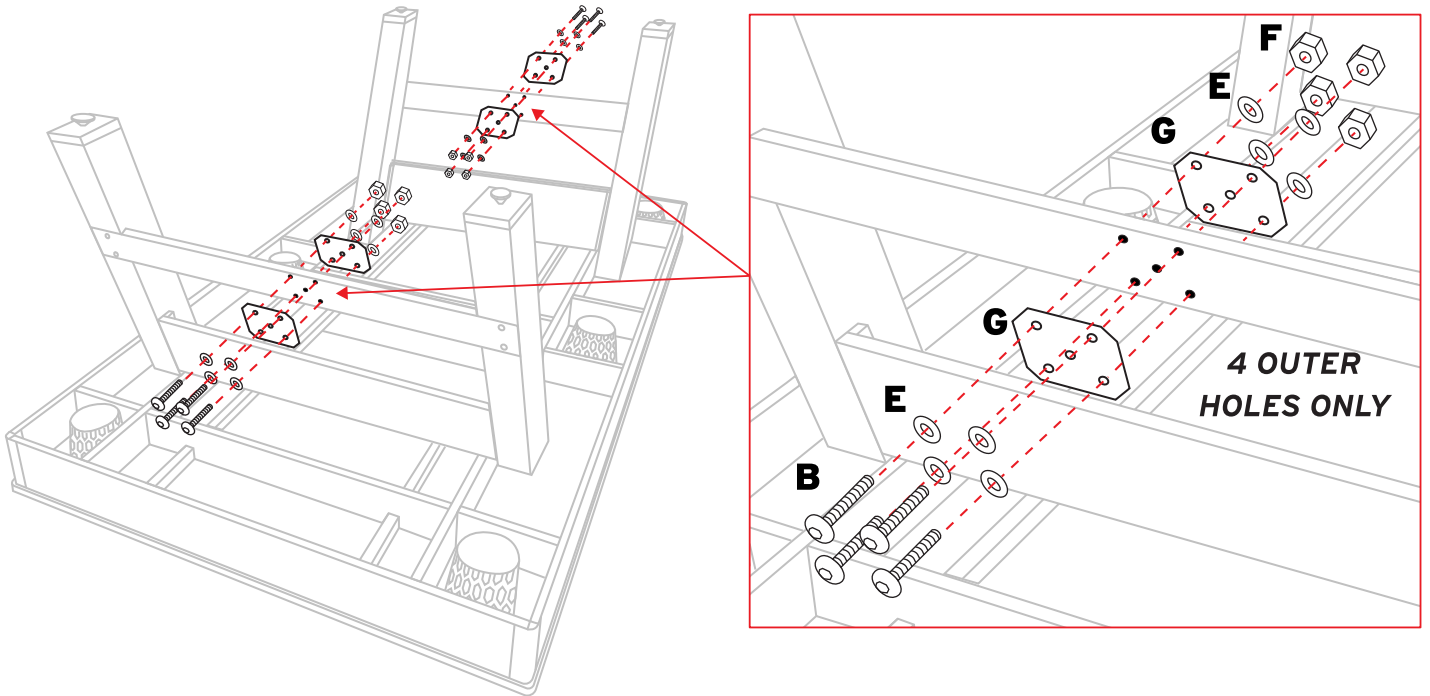

- Take one *tie rod (M)* and hook it to the center ring. Adjust the rod longer (if needed) so it reaches *fixed plate (G)*. The bolt hole on part (M) aligns with the center hole on *fixed plate (G)*. Attach using one 6.3mm x 50mm *bolt (C)* and one 6.3mm *washer (E)* on the exterior and one 6.3mm *washer (E)* and one 6.3mm *lock nut (F)* on the interior. Now tighten the *tie rod (M)* so that it pulls taut on the ring. Repeat on opposite side.

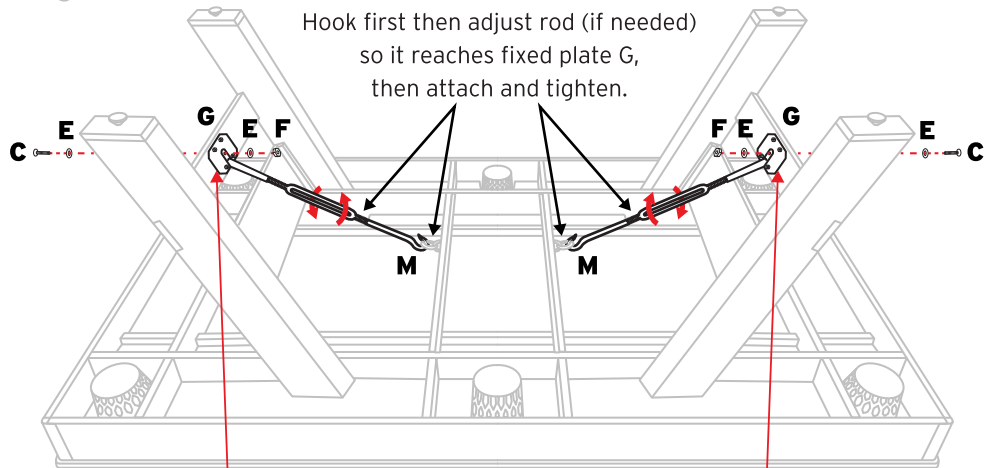

**Align with the center hole on fixed plate**

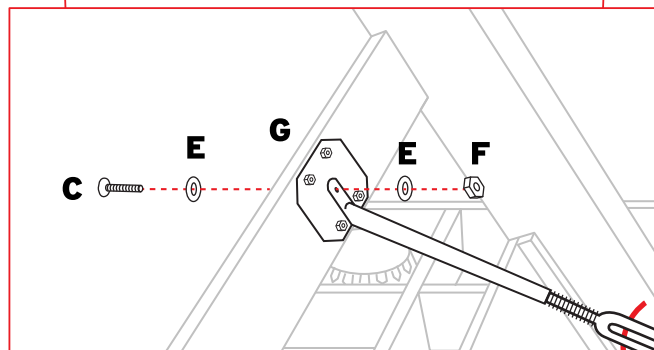

- Check all the bolts and connections to ensure everything is tight and secure.
- With 4 people, carefully lift and tilt the table right side up.
- When lifting do NOT leverage the weight of the table on the legs, as this can cause serious damage and injury. The table must be fully lifted off the ground by 4 or more able bodied adults
- Adjust the feet as needed to ensure the playing surface is level (both long end and short end), level required.

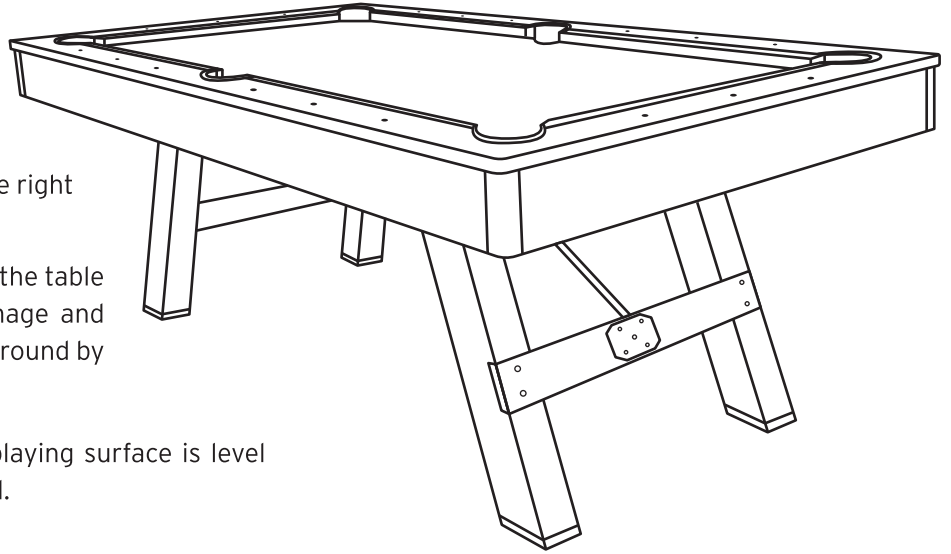

*Before use, confirm that the table is free of damage or defects and contact [Info@PlayGoSports.com](mailto:Info@PlayGoSports.com) for assistance.*

*\*Assemble the sticks by screwing together a top piece and bottom piece for each stick*

## **!** WARNING

- Assembly requires 4 adults
- Seek professional assembly if you are unable to do so yourself.
- Never sit, stand or lean on the table, and never allow children to play on or around the table
- Be careful when holding/using the cue sticks, always be aware of surroundings
- Do not crowd the table when a player is shooting as a ball may jump up out of the table
- Never leave out or use in the elements. Indoor use only.

## **Care Instructions:**

- Never strike the felt with the cue or any other object and always supervise children to ensure proper use. The tables are made using premium felt, however improper shots can cause the felt to tear or rip and is not covered under warranty. If a tear develops, contact your local billiards supply store for repair and/or re-felting.
- Never let children play unsupervised and closely monitor for proper use.
- Indoor Use Only
- Periodically check hardware and tighten as needed. Immediately discontinue use and isolate table if any parts break or if table becomes structurally unsafe.

**Warranty Information:** [www.PlayGoSports.com/Warranty](http://www.PlayGoSports.com/Warranty)

---

## **Customer Service:**

If you have any questions or concerns regarding your GoSports® Billiards Table, please reach out to us at [Info@PlayGoSports.com](mailto:Info@PlayGoSports.com) and we will get back to you right away. We stand behind our products 100% and want to make sure you get the full enjoyment that you paid for.

## Standard 8-Ball Game Play - 2 Players

### Objective:

In standard 8 ball games the first player to pocket all of their balls (either stripes or solids), plus the 8 ball into the scoring pockets, wins.

### Playing the Game:

- First rack the balls near the top center of the table by evenly placing stripes and solids inside the rack and the 8 ball in the center, and then remove the ball rack
- Players will decide who will “break” (coin toss, rock paper scissors, youngest, etc.)
- To break, a player will shoot from the opposite end using the white cue ball
- If any balls are pocketed in the break, the breaker will go again, and they can choose to play either stripes or solids for the remainder of the game by successfully pocketing a ball from either group
- If no balls are pocketed on the break, it is the next player’s turn and they can choose to be either stripes or solids by successfully pocketing a ball from either group
- Once stripes and solids have been assigned, players will continue alternating turns attempting to pocket their respective balls into the scoring pockets using the cue ball
- Whenever a player successfully pockets one of their balls, they go again
- In the event of a foul, the offending player loses a turn (see ‘Fouls’) and the other player can reset the cue ball anywhere on the table for their turn

*Note: Balls pocketed as a result of a foul remain pocketed*

- The 8 ball must be played last, if either player prematurely pockets the 8 ball they automatically lose

### Fouls:

A player fouls if:

- The cue ball is pocketed
- The cue ball fails to hit any of that player’s target balls (either stripes or solids)
- The cue ball fails to hit any target balls (either stripes or solids)
- A target ball jumps the table

### Winning:

Once either player has pocketed all of their respective balls (either stripes or solids), and then pockets the 8 ball, that player wins!

## Using the Cue Chalk:

Use the included Cue Chalk between shots to ensure the tip of the cue stick doesn’t slide off the ball on contact, and to keep the Cue Stick in good condition. Chalking the cue stick is best done at an angle, away from the billiards table. Use a round motion over the tip of the cue to apply it evenly and set the chalk upright when done to avoid residue on the table.