

CARE AND MAINTENANCE

Always use felt pads under all articles to prevent discoloration or softening of the lacquer. Plastic and rubber bases on items can discolor wood. Wipe up spills immediately and avoid common hazards such as hot dishes, harsh solvents and abrasives. Cleaning should be done with a soft lint free cotton cloth dampened with water or furniture polish. On highly used surfaces we recommend applying a quality paste wax which should be used on a regular basis to provide additional protection from scratches and spills. How often you apply the wax depends on how much wear the furniture receives.





NOTICE

* Please make sure that you have all parts indicated before you begin assembly of this item

* This item should be assembled on a soft surface to prevent scratching the finish during assembly

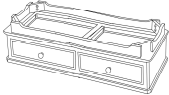
* This item may require periodic tightening

Part List

PIECE	DESCRIPTION	PICTURE	QUANTITY
A	Table Top		1X
B	Leg		4X
C	Allen Key Driver		1X
D	Allen Bot 8x1.41x45mm		8X
E	Flat Washer		8X

Product Dimensions: 35.5"W x 13"D x 29.5"H



PREPARATION

Before beginning assembly of product, make sure all parts are present. Compare parts with package contents list
If any part is missing or damaged, do not attempt to assemble the product.
Estimated Assembly Time: 5 minutes.

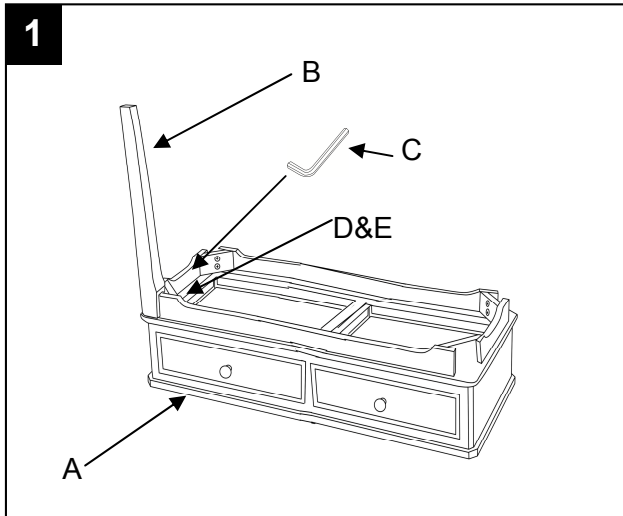

Step 1

Take all packaging off the table.
Screw 1 leg to the bottom of the table top.
2pcs screws & flat washers required.
Allen key driver required.

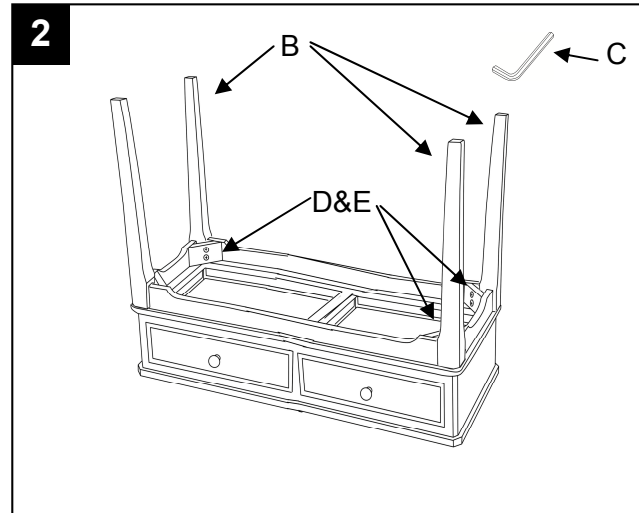

Step 2

Screw rest 3 legs to the bottom of the table top.
6pcs screws & flat washers required.
Allen key driver required.

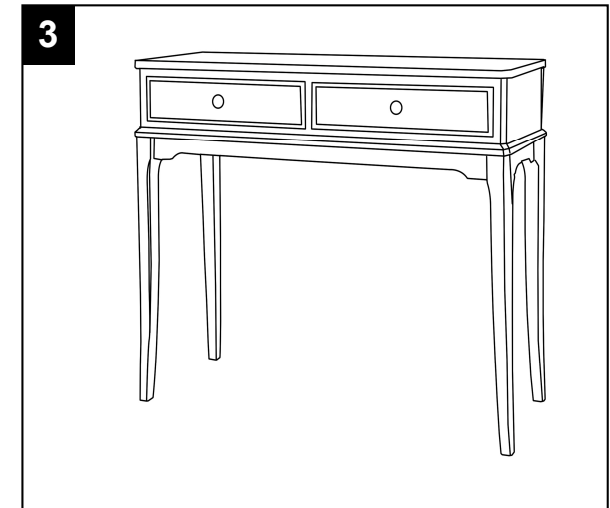

Step 3

Turn the table up to the right side.
Assembling process done.