

FLUTED SHOE CABINET WITH 4 FLIP DRAWERS

ASSEMBLY INSTRUCTION

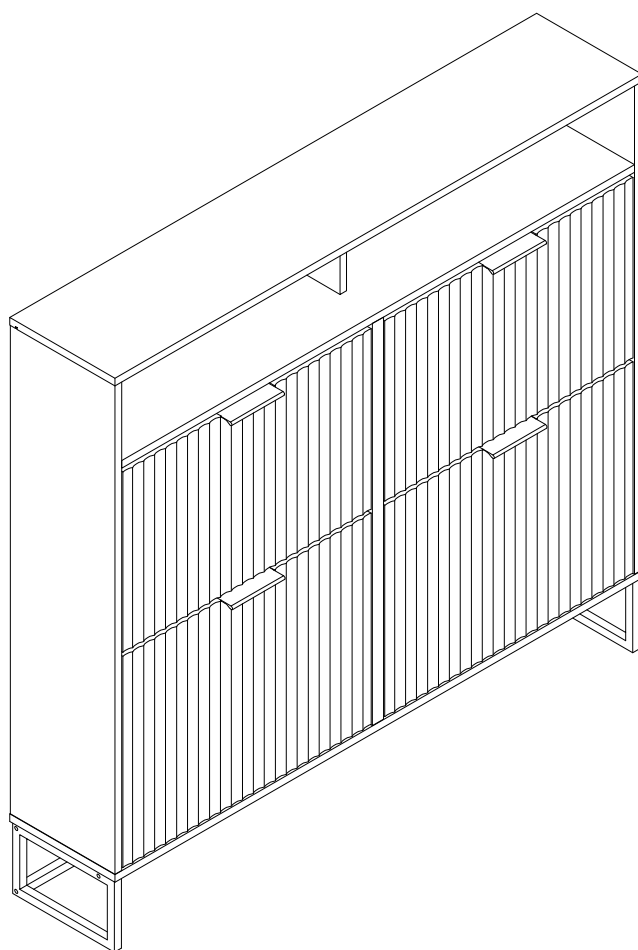

Thank you for purchasing
Please contact us via email if parts are missing or damaged, we will
gladly ship your replacement parts free of charge

⚠ IMPORTANT

THIS INSTRUCTION BOOKLET CONTAINS IMPORTANT SAFETY INFORMATION.
PLEASE READ AND KEEP FOR FUTURE REFERENCE.

RETURN & WARRANTY

Thank you for choosing our product!

We would like to take this opportunity to thank you for choosing

We hope that you are completely satisfied with your purchase, and enjoy it for years to come.

Your satisfaction is our highest pursuit.

Return policy

We believe you will absolutely love your furniture, but if for some reason you want to return the product, please contact us directly before you decide to return your product to the retailer. Our Customer Service organization can answer most concerns and can assist you with any questions you may have about your new product.

The item must be returned in good condition, in original box, with all original proof of purchase, parts and accessories, within the time frame specified by the retailer it was purchased from.

Warranty

We warrant this product to be free from defects in material and workmanship agrees to remedy any such defect. This warranty covers one year from the date of original purchase. This is solely limited to be repair or replacement of defective parts and no assembly labor is included.

This warranty does not apply to any product which has been improperly assembled, subjected to misuse or abuse or which has been altered or repaired in any way.

Components repaired or replaced warranted through the remainder of the original warranty period only. The defective components will be repaired or replaced without charge, subject to the terms and conditions described above.

For help with assembly, identifying parts, product information or to order parts, please contact us freely.

BEFORE STARTING

Before Using Product



- Read each step carefully before starting. It is very important that each step is performed in the correct order. If these steps are not followed in sequence, assembly difficulties will occur.



- Make sure all parts are included. Most board parts are labeled or stamped on the raw edge.

- Prepare a flat and Philips screwdriver (not included) A Power Screwdriver is recommended.



- Work in a spacious area and near where the unit will be used, preferably on a carpet, or use a piece of the cardboard packaging to protect your floor and product.



- For a smooth assembly process, we suggest you keep a lite tightness for all the screws during assembly. After the whole product is assembled, firmly tighten all the screws.



! WARNING :

- Do not allow children to climb on unit
- Serious or fatal crushing injuries can occur from furniture tip-over. To prevent this furniture from tipping over, it must be permanently fixed to the wall. Fixing devices for the wall are not included since different wall materials require different types of fixing devices. Use fixing devices suitable for the walls in your home. For advice on suitable fixing systems, contact your local specialized dealer
- Avoid sharp objects or corrosive chemicals to prevent damage to the product
- During assembly, keep parts and packaging materials away from children and pets as there could be potential injury and choking hazards

ASSEMBLY TIPS

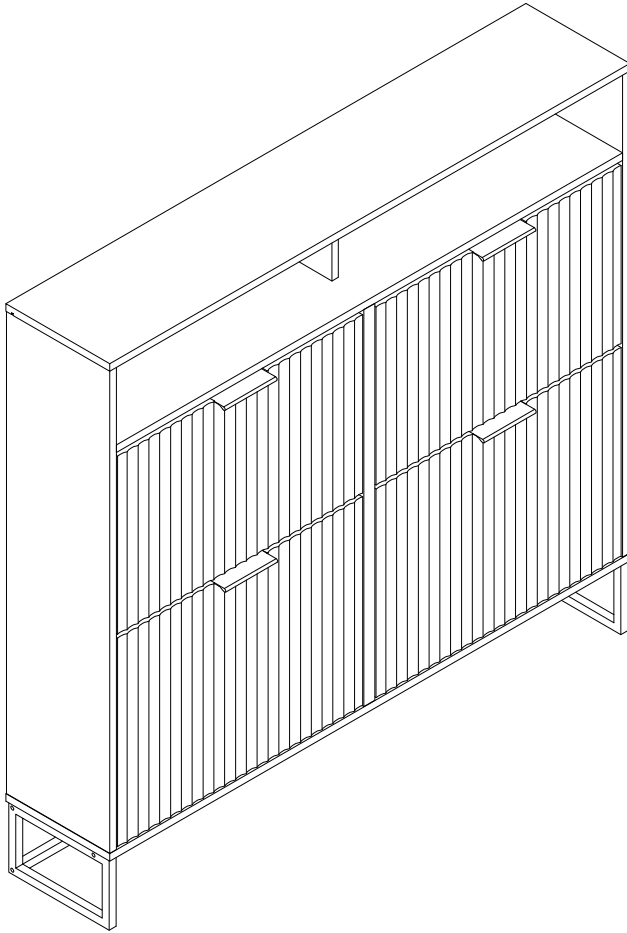

OVERALL SIZE:

120.1 x 24 x 113.5 cm (L x W x H)

47.2 x 9.4 x 44.6 inch (L x W x H)

FEATURES:

1. Mid-Century Modern Style
2. Unique Fluted Design
3. Fashionable Golden Metal Handle
4. 4 Flip Drawers
5. Wide Top with Apron Design



Estimated Time for Assembly

150-180 mins



Estimated People For Assembly

2

Caution:

1. This product is designed for home use and not intended for commercial use.
2. This product contains small components. Please ensure that they are kept away from small children.
3. Be careful when using power tools to assemble your furniture. Power tools may strip or damage the parts.

IDENTIFY PARTS

One unit per box

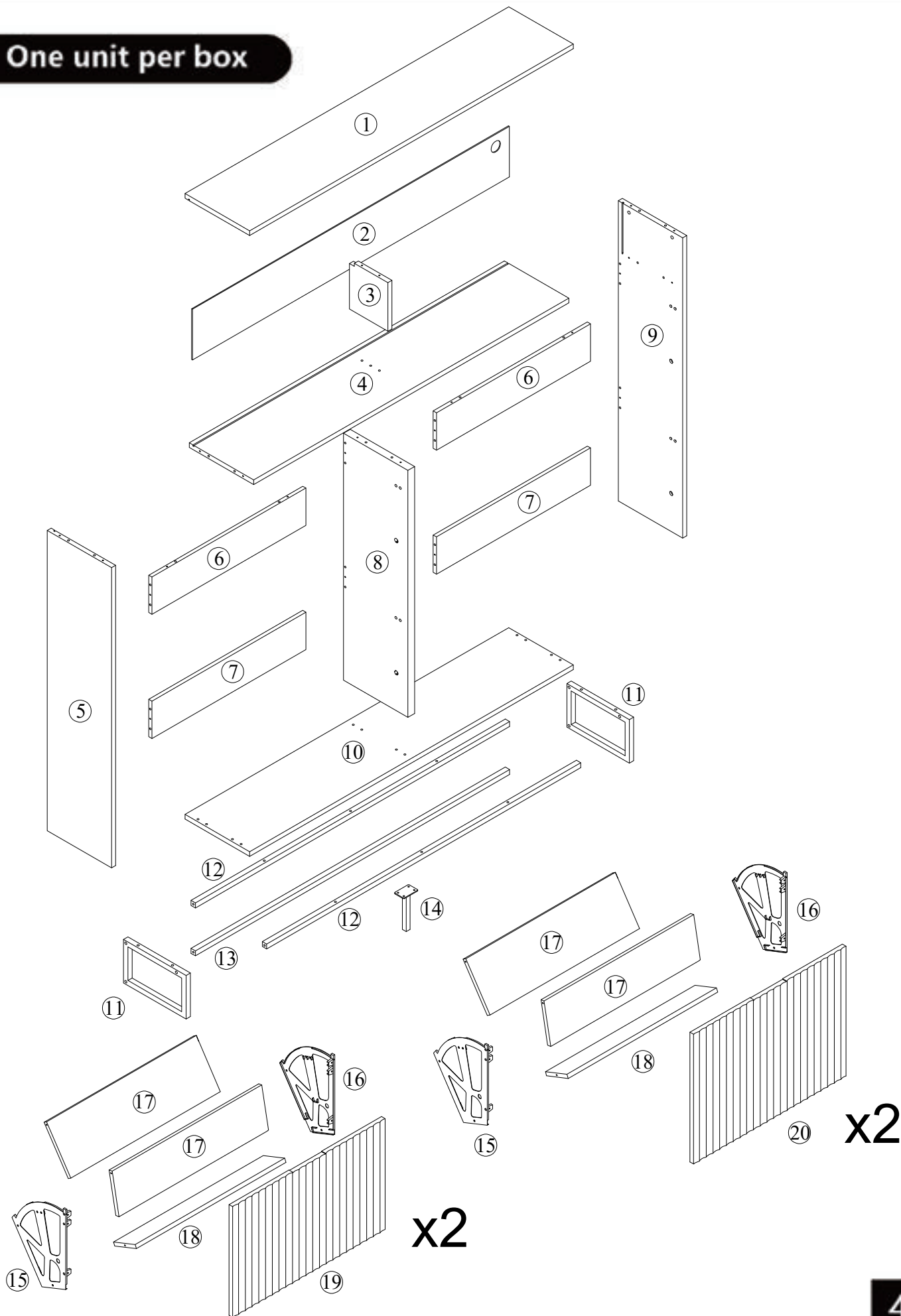

COMPONENTS

1

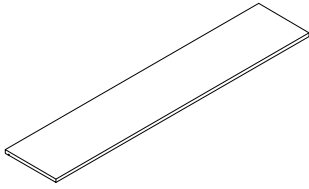

1200x239x15mm

Top Panel x1

2

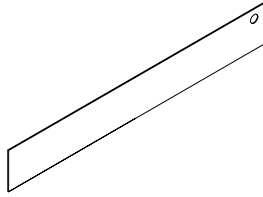

1176x163mm

Top Back Panel x1

3

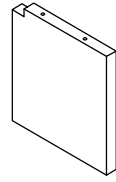

155x142x14mm

Upper Partition Panel x1

4

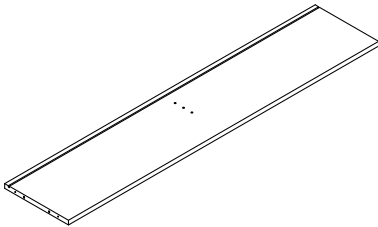

1168x238x15mm

Middle Bottom Panel x1

5

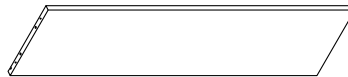

964x238x15mm

Left Side Panel x1

6

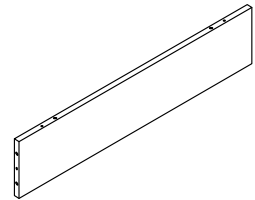

571x119x12mm

Upper Back Strip x2

7

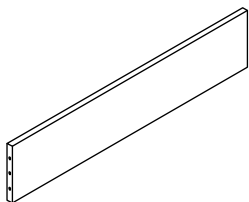

571x119x12mm

Lower Back Strip x2

8

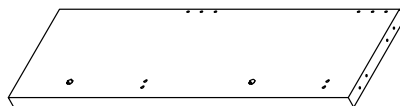

793x238x25mm

Lower Partition Panel x1

9

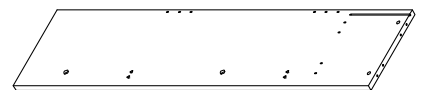

964x238x15mm

Right Side Panel x1

COMPONENTS

10

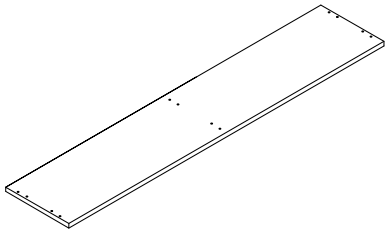

1200x239x15mm

Bottom Panel x1

11

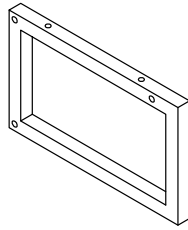

232x140x16mm

Side Metal Frame x2

12

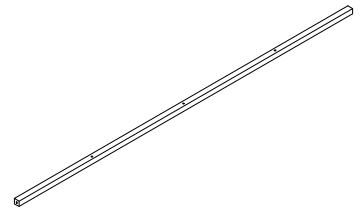

1166x16x16mm

Upper Metal Strip x2

13

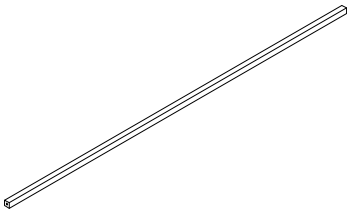

1166x16x16mm

Bottom Metal Strip x1

14

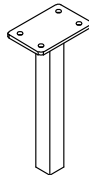

138x60x40mm

Metal Supporting Leg x1

15

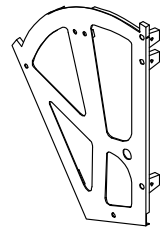

Left Swivel Rack Bracket x4

16

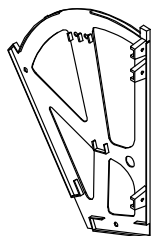

Right Swivel Rack Bracket x4

17

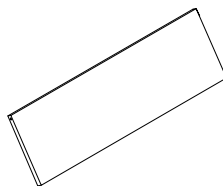

559x135x12mm

Flip Drawer Back Panel
& Divider x8

18

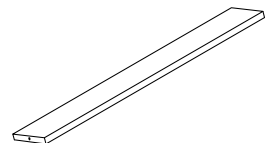

559x85x12mm

Flip Drawer Bottom Panel x4

COMPONENTS

19

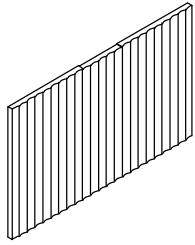

566x356x15mm

Upper Flip Drawer Front Panel x2

20

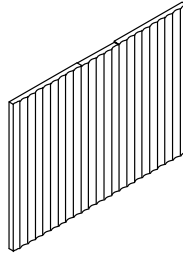

566x417x15mm

Lower Flip Drawer Front Panel x2

"A & B" Hardware installation example

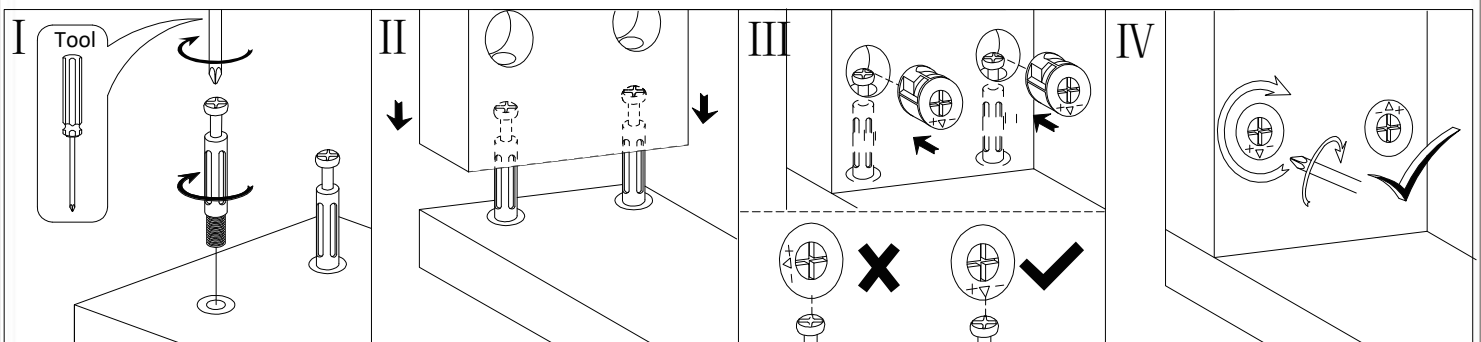

COMPONENTS

A

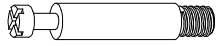

+2(spare)

Φ6X35mm

Cam Bolt x24

B



+2(spare)

Φ15X10mm

Cam Lock x24

C

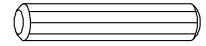

+4(spare)

Φ6X30mm

Wood Dowel x37

D



Φ5X40mm

Screw x8

E

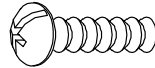

Φ4X8mm

Screw x8

F

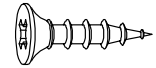

+5(spare)

Φ3.5X14mm

Screw x48

G

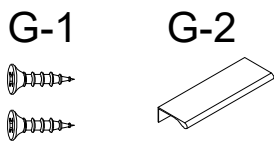

Φ3X12mm

Drawer Handle & Handle Screw x4

H

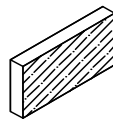

Non-Slip Mat x4

I



L - Shaped Wrench x1

J

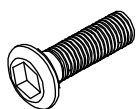

+1(spare)

Φ6X25mm

Screw x10

K

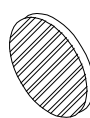

Hole Cover Sticker x6

L

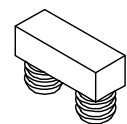

Door Bumper x8

COMPONENTS

M



Accessory M x8

N



Φ4X45mm
Plastic Anchor &
Washer & Screw x2

O

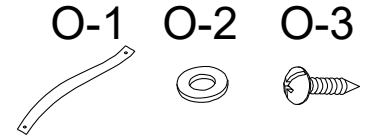

Φ4X12mm
Anti-Tip Strap &
Washer & Screw x25

P

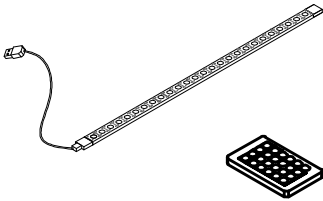

LED Strip Lights &
Remote Control x1

Q

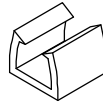

Led Strip Light Clips x6

R

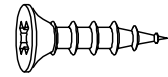

Φ3X12mm
Screw x6

S

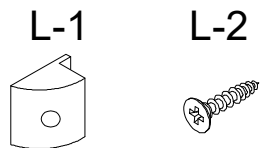

Φ3X16mm
Mending Wedge & Screw x4

T

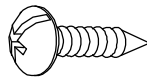

Φ4X12mm
Screw x4

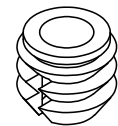

(spare)

Plastic Self Drilling
Drywall Anchor x5

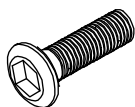

U



+1(spare)

Φ6X35mm
Screw x6

ASSEMBLY STEPS

A x 6	M6x35mm	P x 1		Q x 6		R x 6	M3x12mm
-------	---------	-------	---	-------	--	-------	---------

STEP 1

1. Attach cam bolt (A) to panel (1).
2. Secure led strip light clips (Q) to panel (1) using screw (R).
3. Insert led strip lights (P) into led strip light clips (Q)

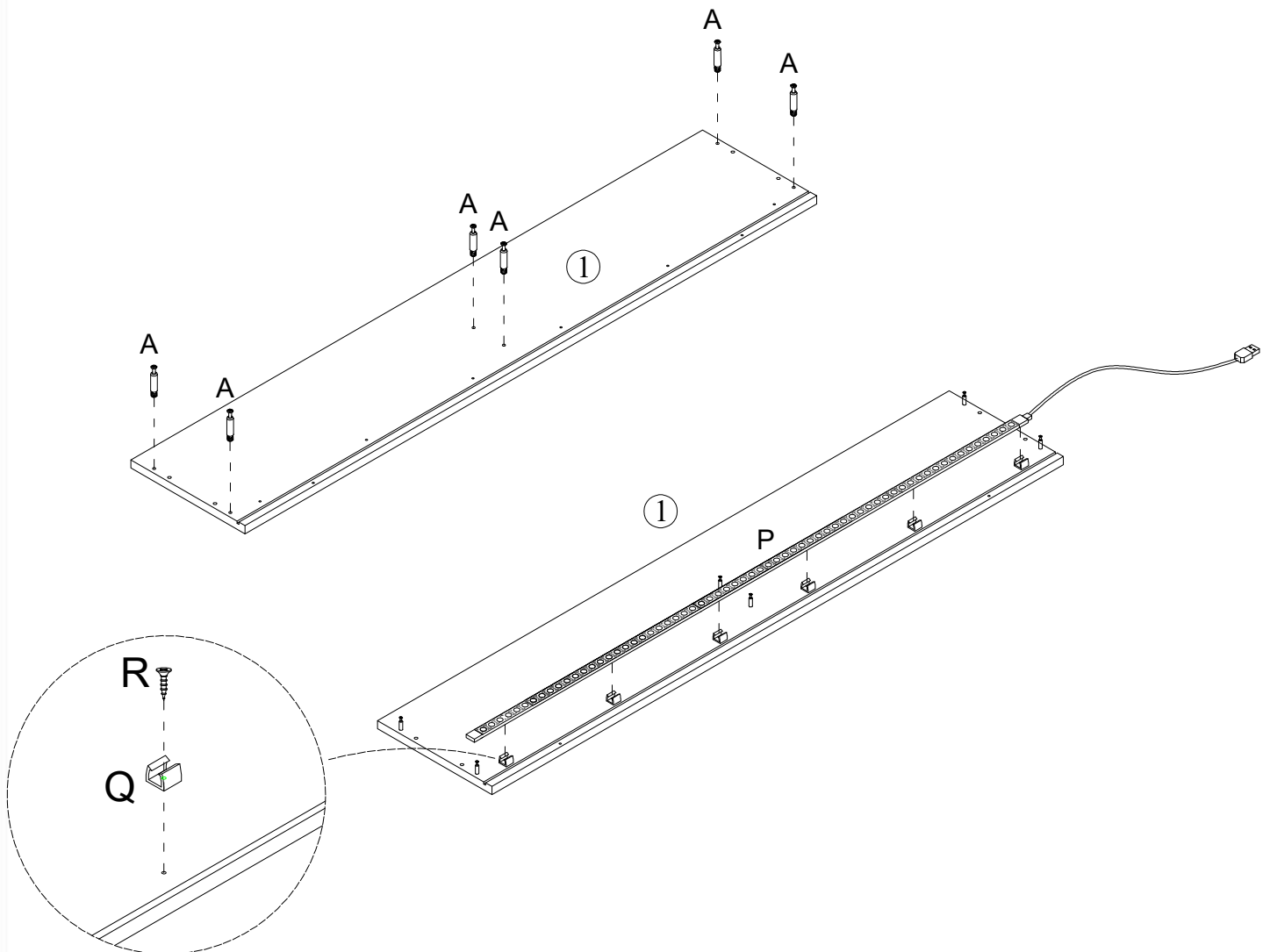

ASSEMBLY STEPS

A x 6



STEP 2

Attach cam bolt (A) to panel (4)

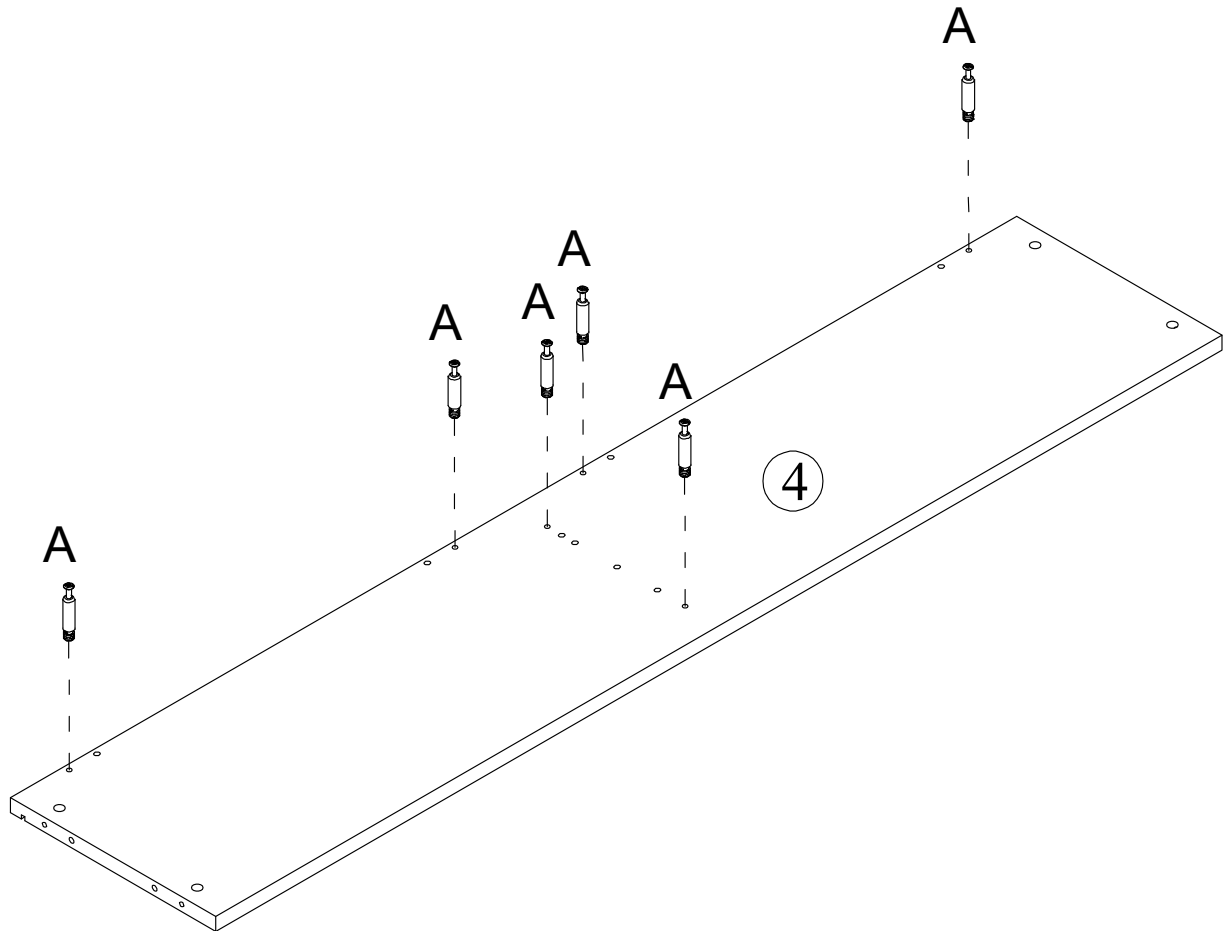

ASSEMBLY STEPS

A x 8	M6x35mm 	L x 4	
-------	--	-------	---

STEP 3

1. Attach cam bolt (A) to panel (5) and (9).
2. Attach door bumper (L) to panel (5) and (9).

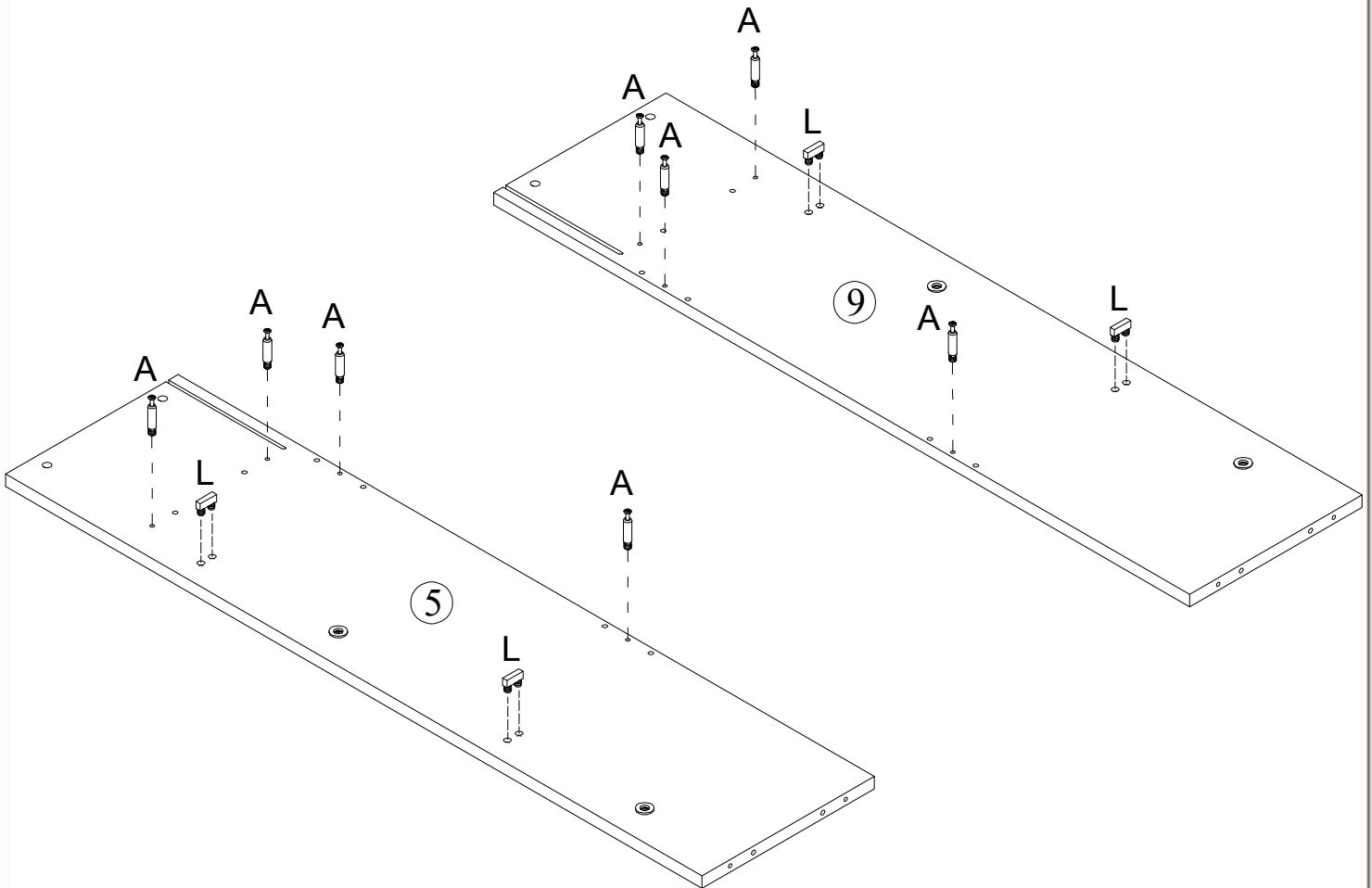

ASSEMBLY STEPS

A x 4	M6x35mm	L x 4	
-------	---------	-------	---

STEP 4

1. Attach cam bolt (A) to panel (8).
2. Attach door bumper (L) to panel (8)

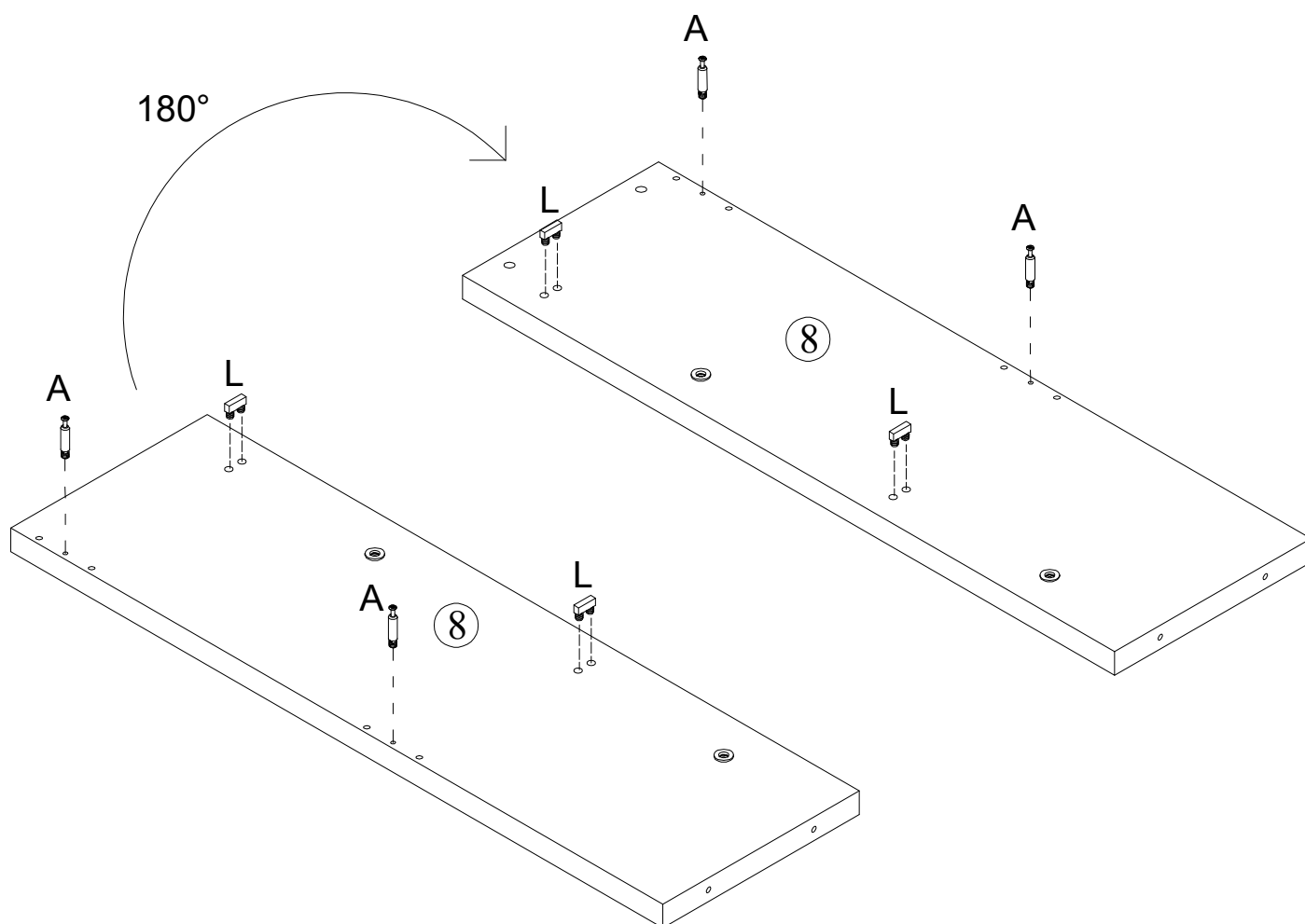

ASSEMBLY STEPS

F x 12

M3.5x14mm



STEP 5

Use screw (F) to secure the left swivel rack bracket (15) and right swivel rack bracket (16) to panel (19)

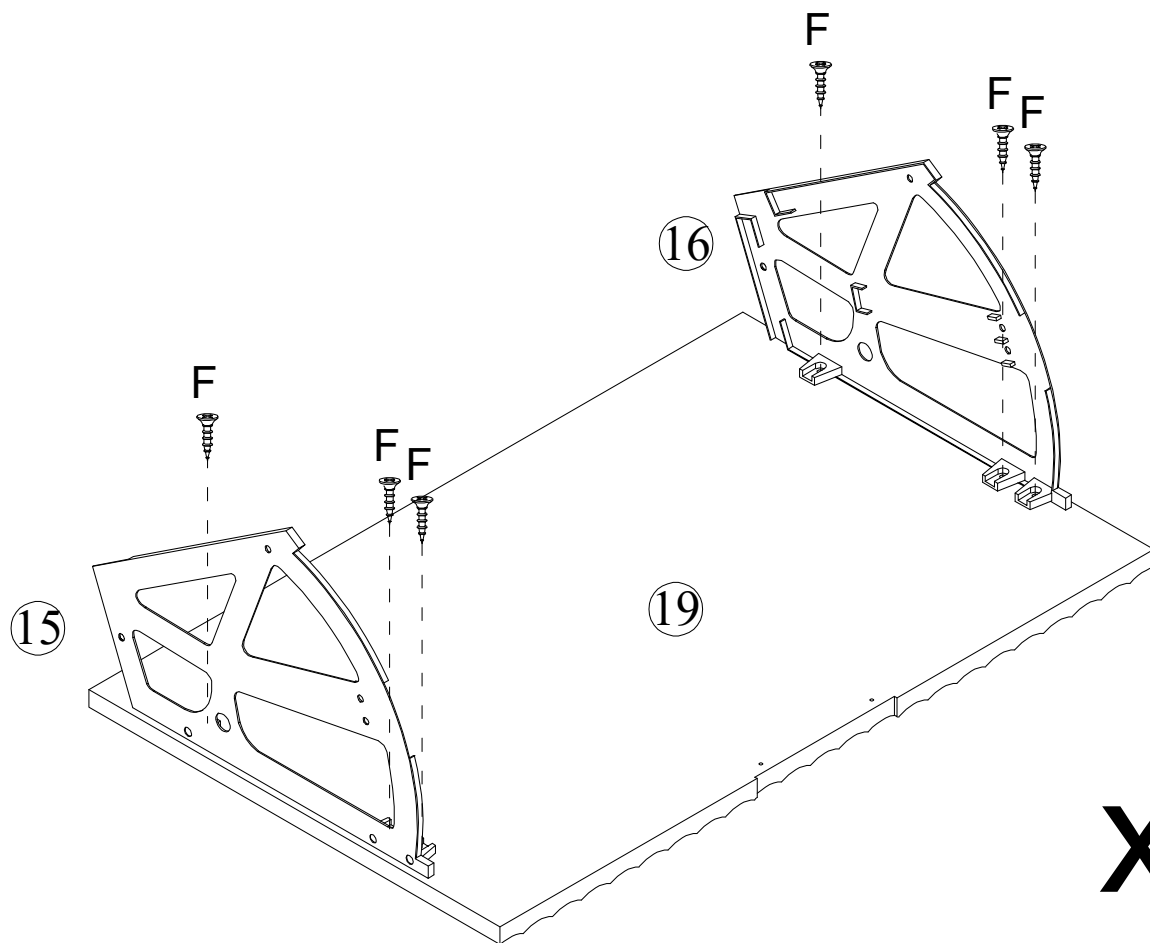

ASSEMBLY STEPS

F x 8	M3.5x14mm 
-------	--

STEP 6

Use screw (F) to connect the swivel rack bracket (15) and (16) to panel (17) and (18)

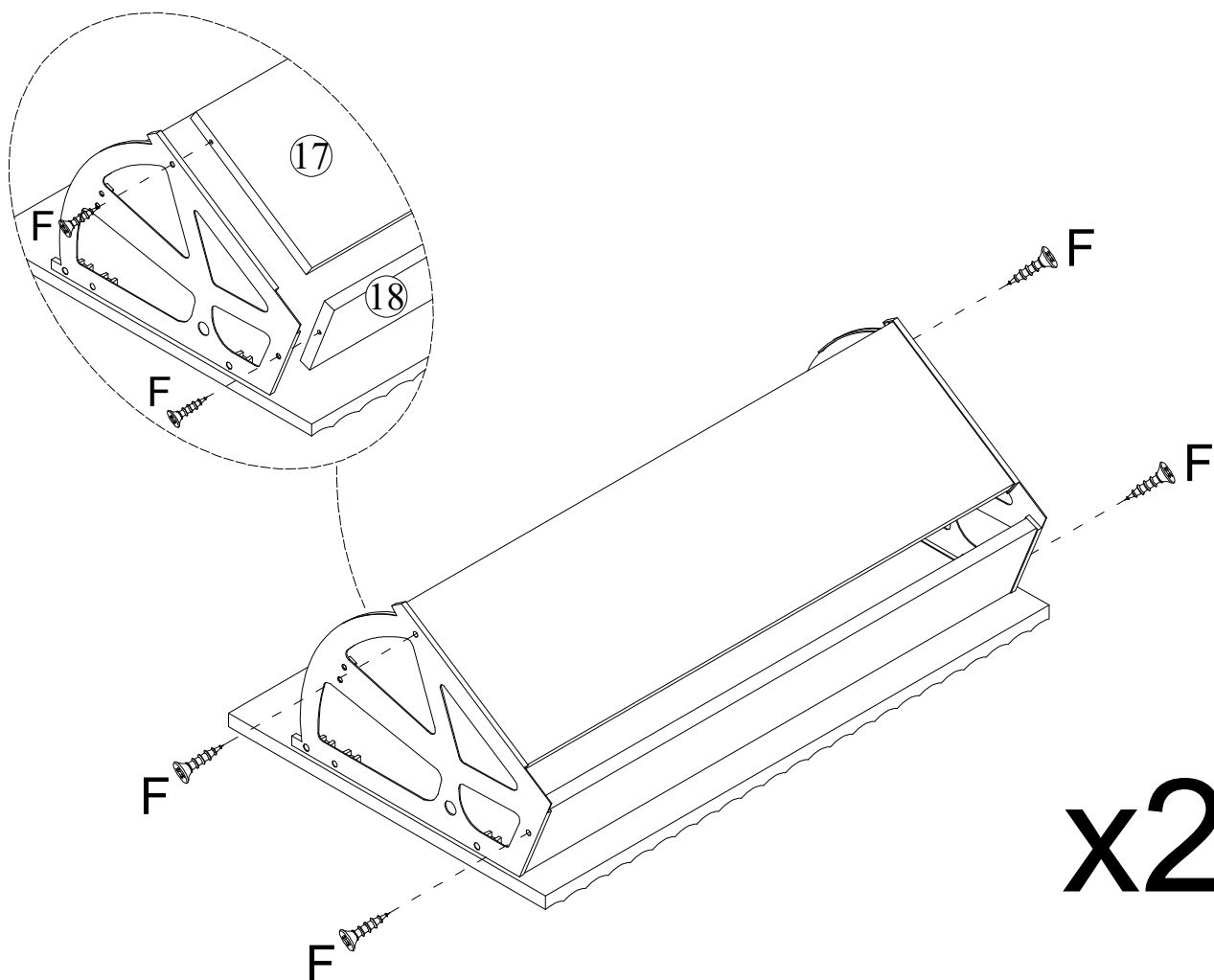

ASSEMBLY STEPS

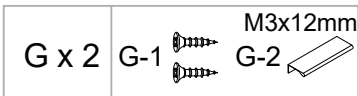

STEP 7

Use handle screw (G-1) to attach drawer handle (G-2) to panel (19)

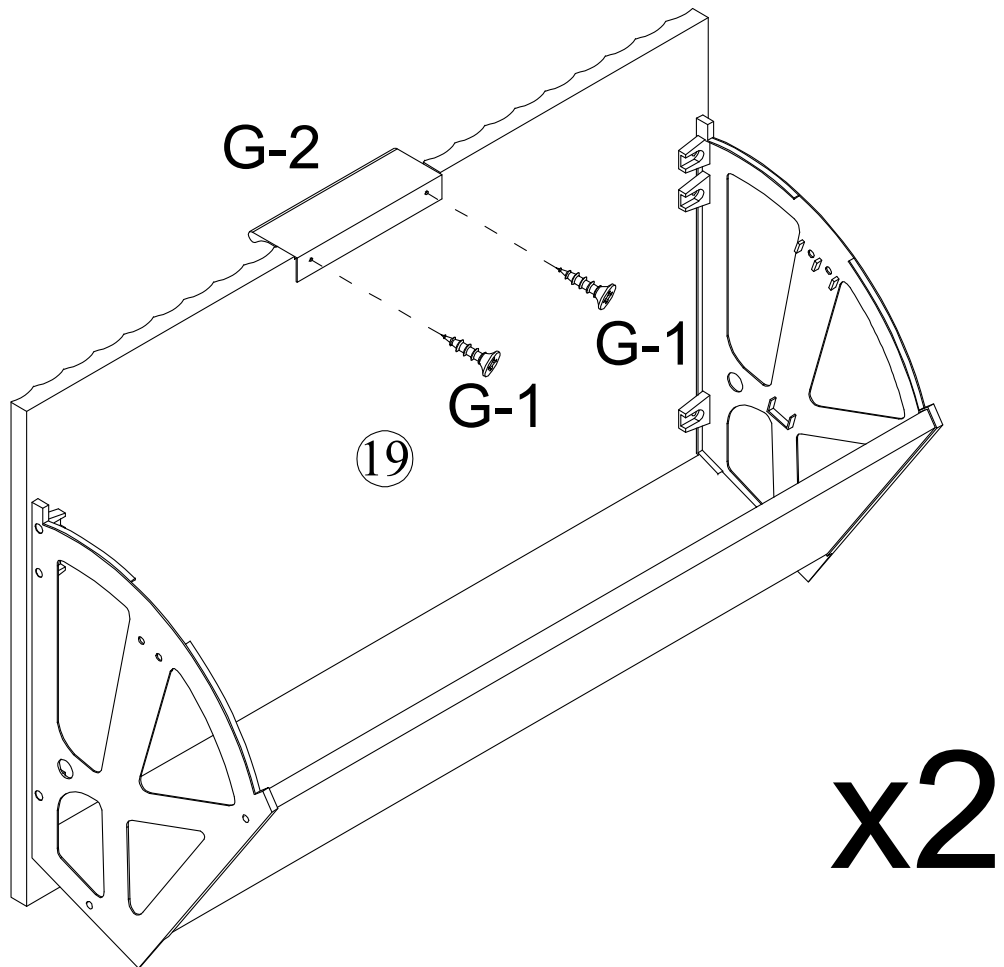

ASSEMBLY STEPS

F x 12

M3.5x14mm



STEP 8

Use screw (F) to secure the left swivel rack bracket (15) and right swivel rack bracket (16) to panel (20)

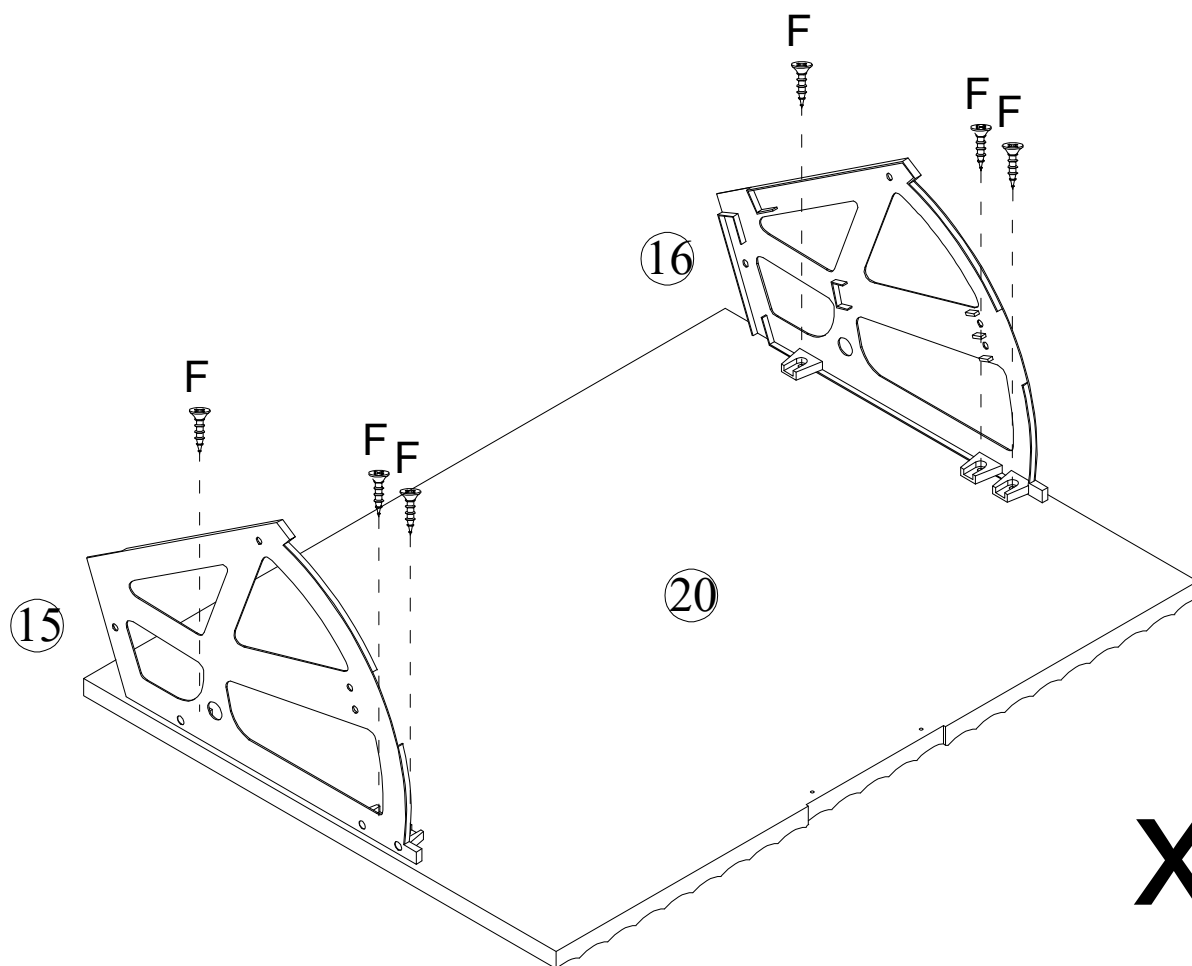

x2

ASSEMBLY STEPS

F x 8

M3.5x14mm



STEP 9

Use screw (F) to connect the swivel rack bracket (15) and (16) to panel (17) and (18)

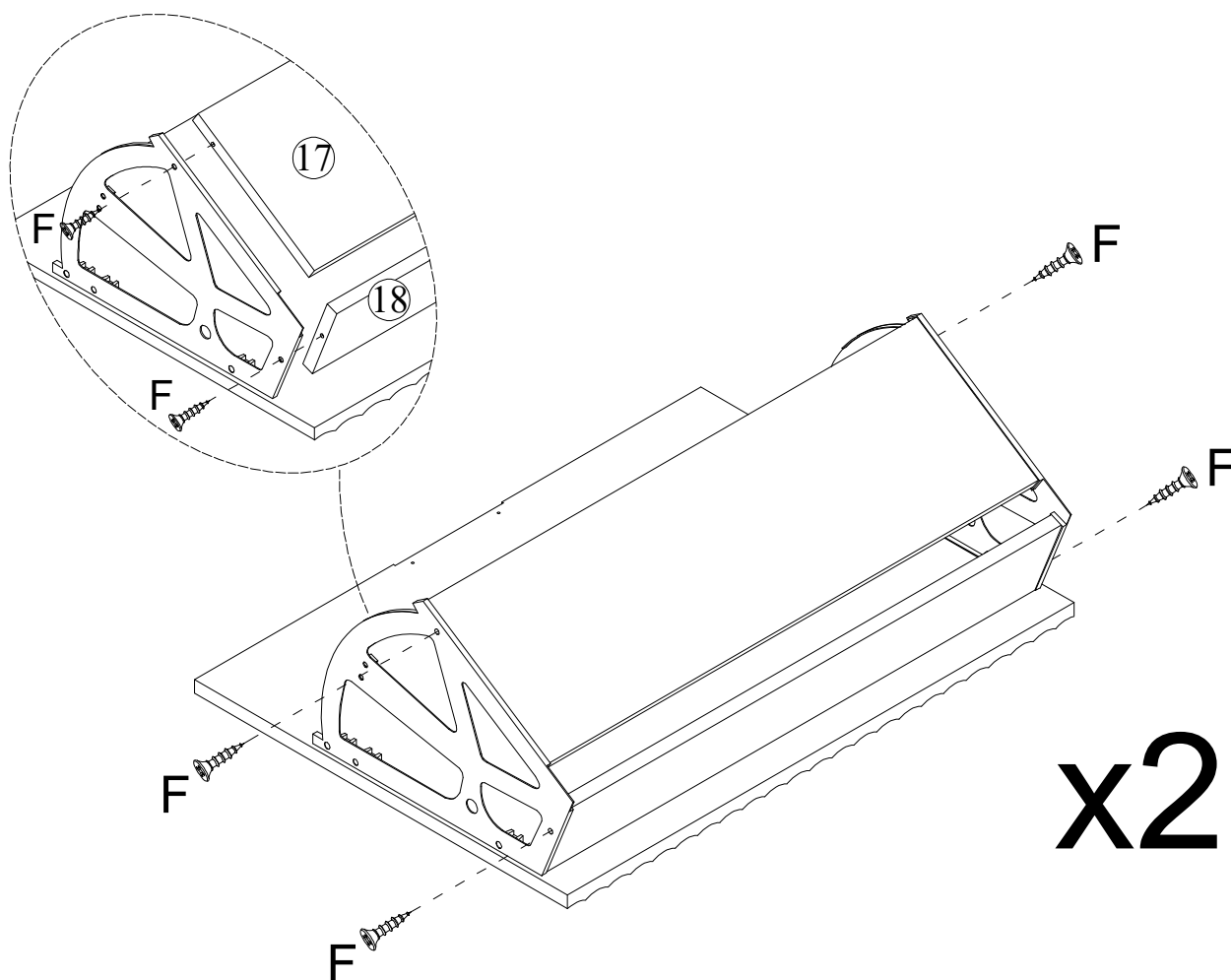

ASSEMBLY STEPS

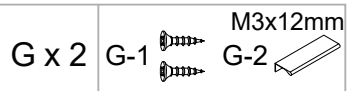

STEP 10

Use handle screw (G-1) to attach drawer handle (G-2) to panel (20)

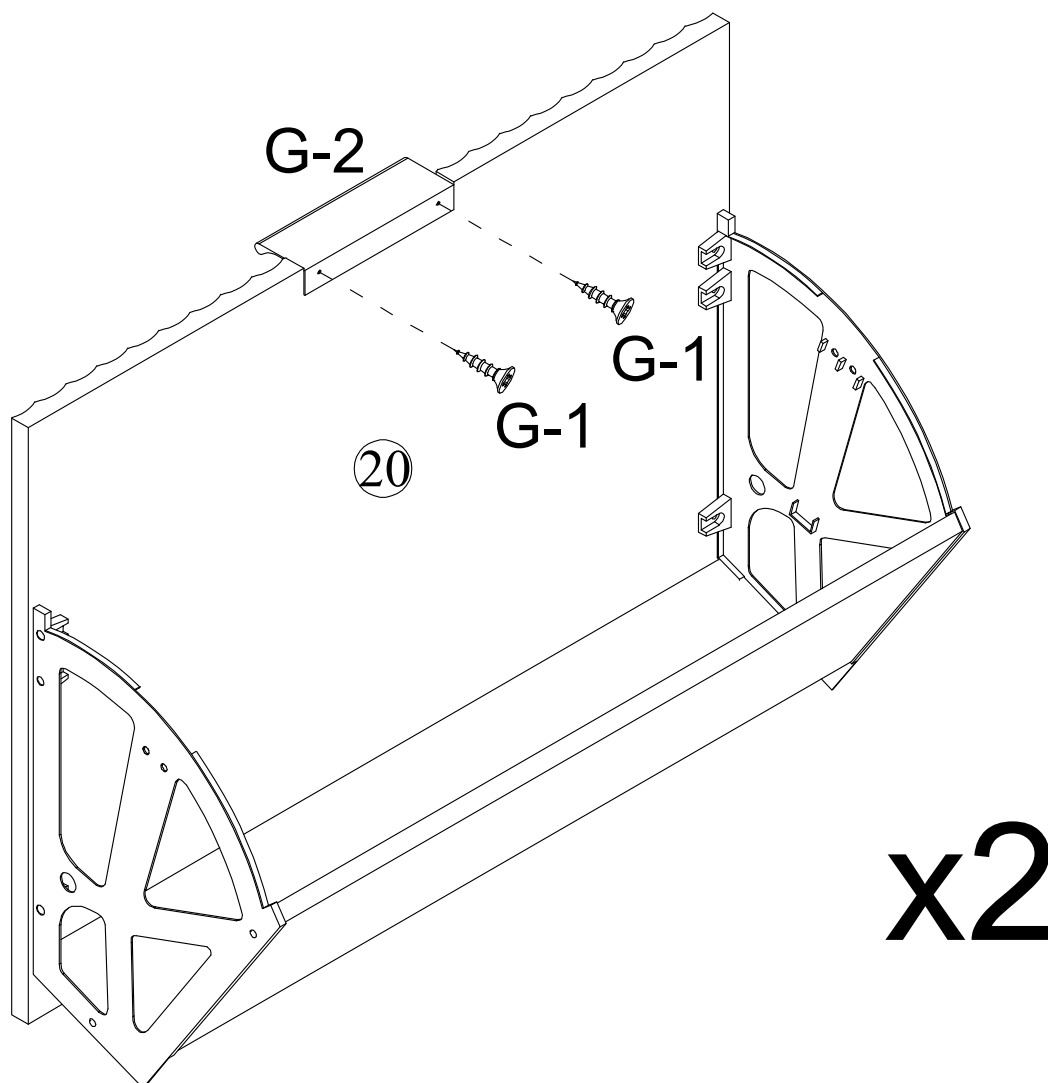

ASSEMBLY STEPS

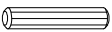

B x 4	M15x10mm 	C x 8	M6x30mm 
-------	---	-------	--

STEP 11

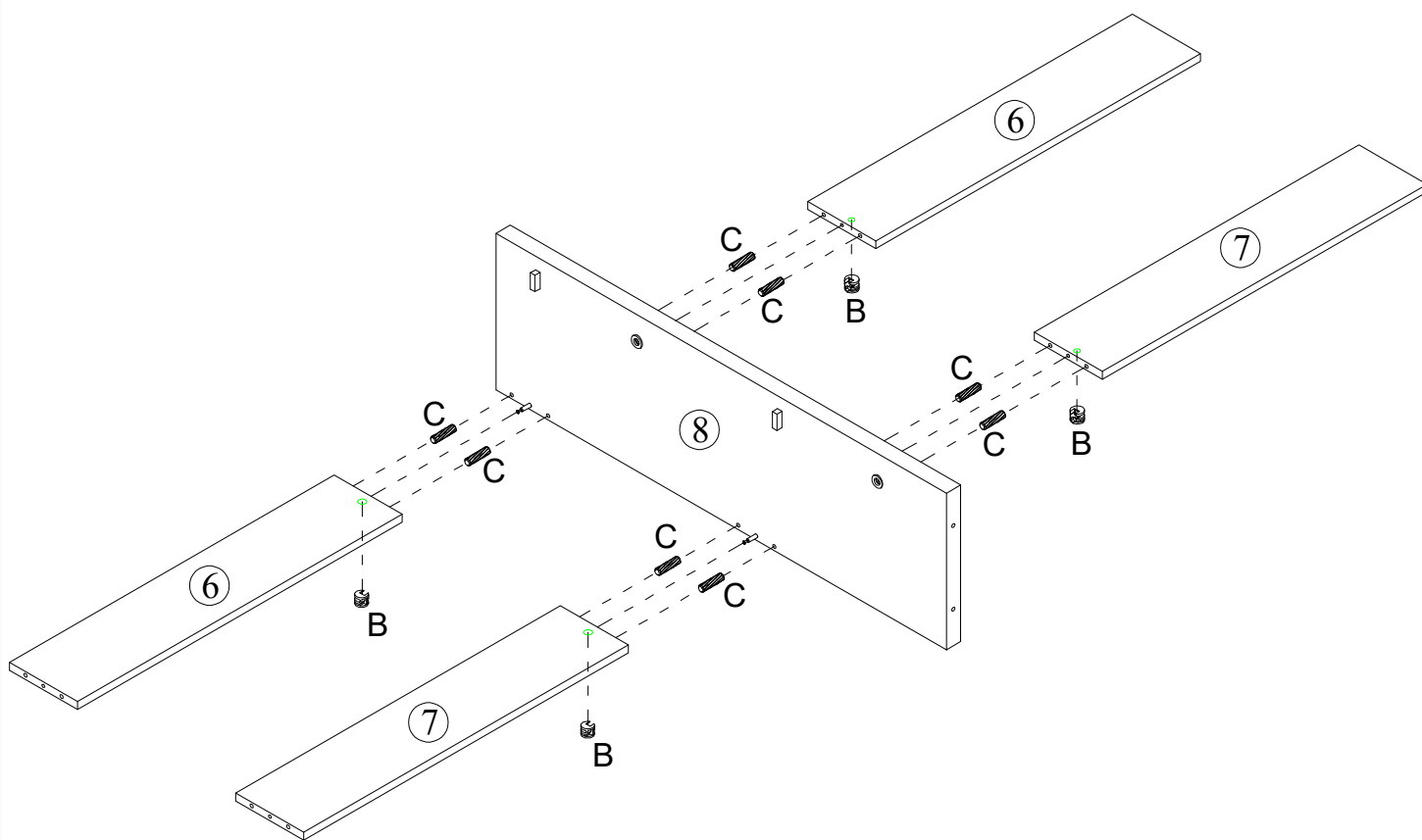
Connect panel (6), (7), and (8) using wood dowel (C), and tighten with cam lock (B)



ASSEMBLY STEPS

C x 1	M6x30mm 	D x 2	M5x40mm 
-------	--	-------	--

STEP 12

Connect panel (3) and (4) using wood dowel (C), and tighten with screw (D)

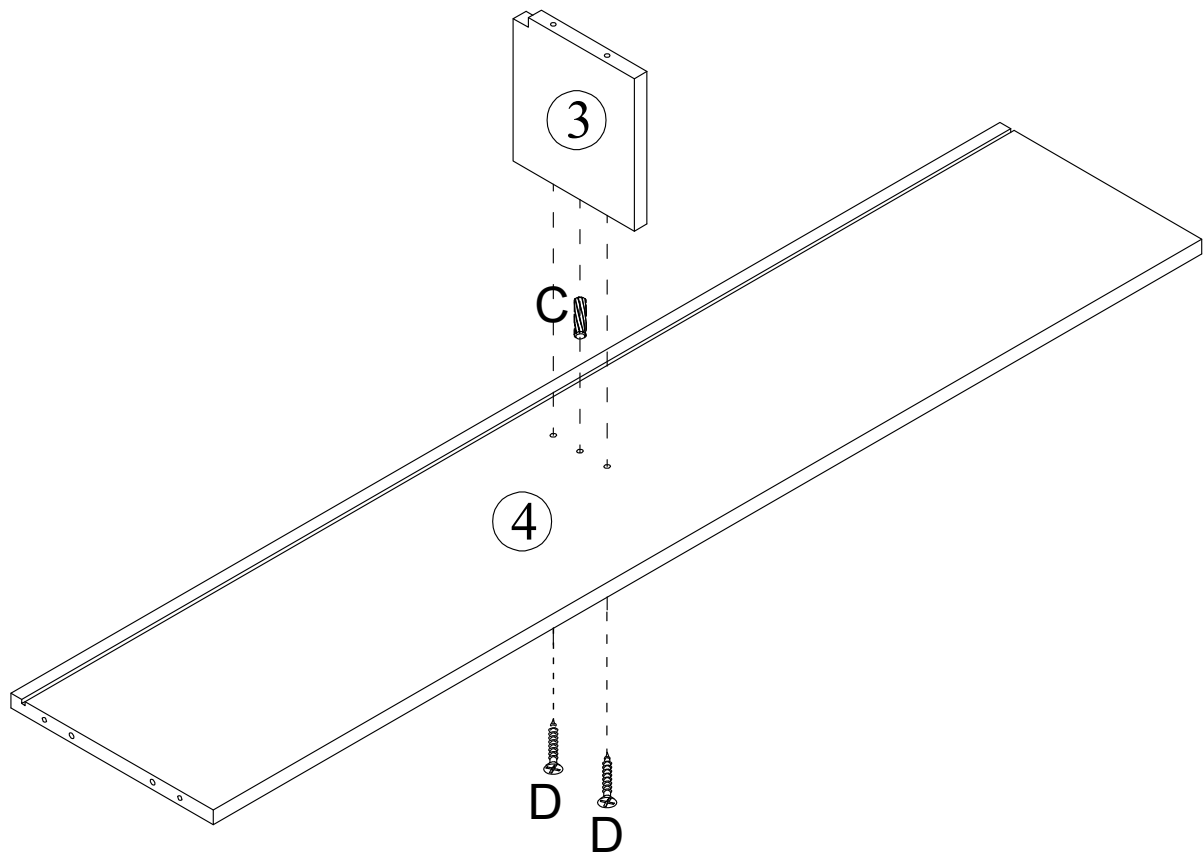

ASSEMBLY STEPS

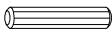
B x 6	M15x10mm 	C x 6	M6x30mm 
-------	---	-------	--

STEP 13

Connect the assembled panel (4) and (8) using wood dowel (C), and tighten with cam lock (B)

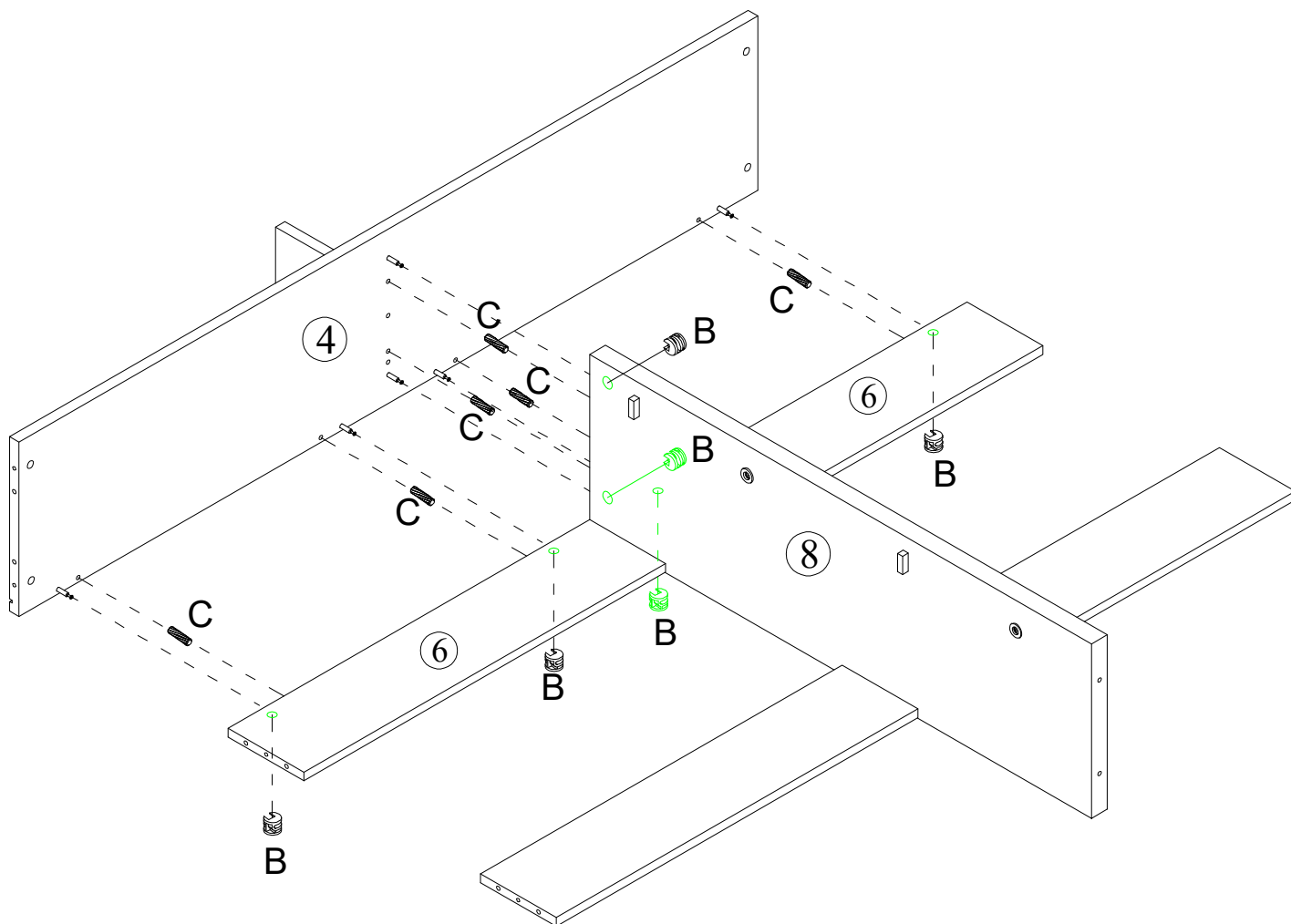

ASSEMBLY STEPS

B x 4



C x 6

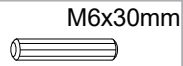

STEP 14

Connect panel (5) using wood dowel (C), and tighten with cam lock (B)

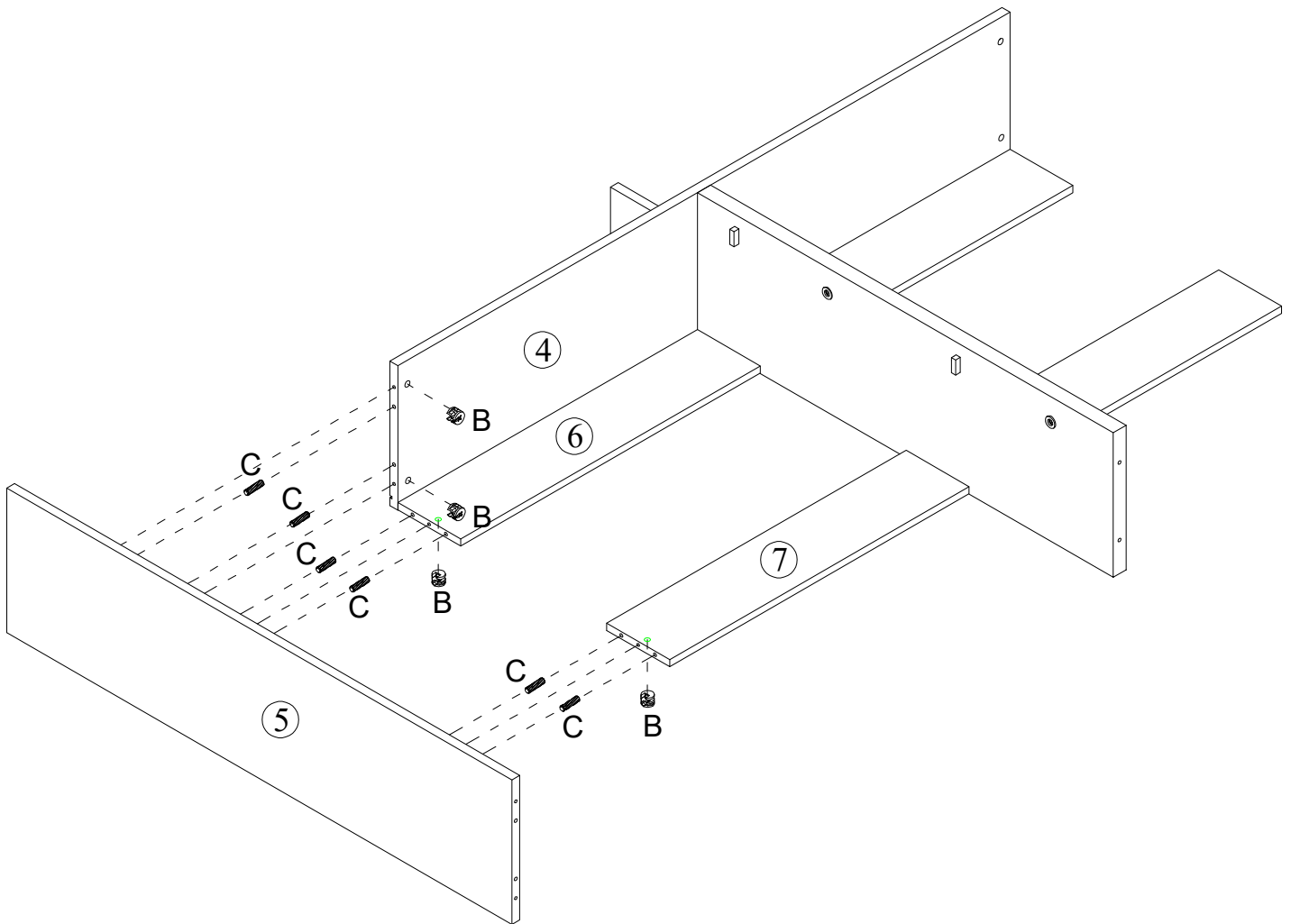

ASSEMBLY STEPS

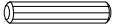

B x 4	M15x10mm 	C x 6	M6x30mm 
-------	---	-------	--

STEP 15

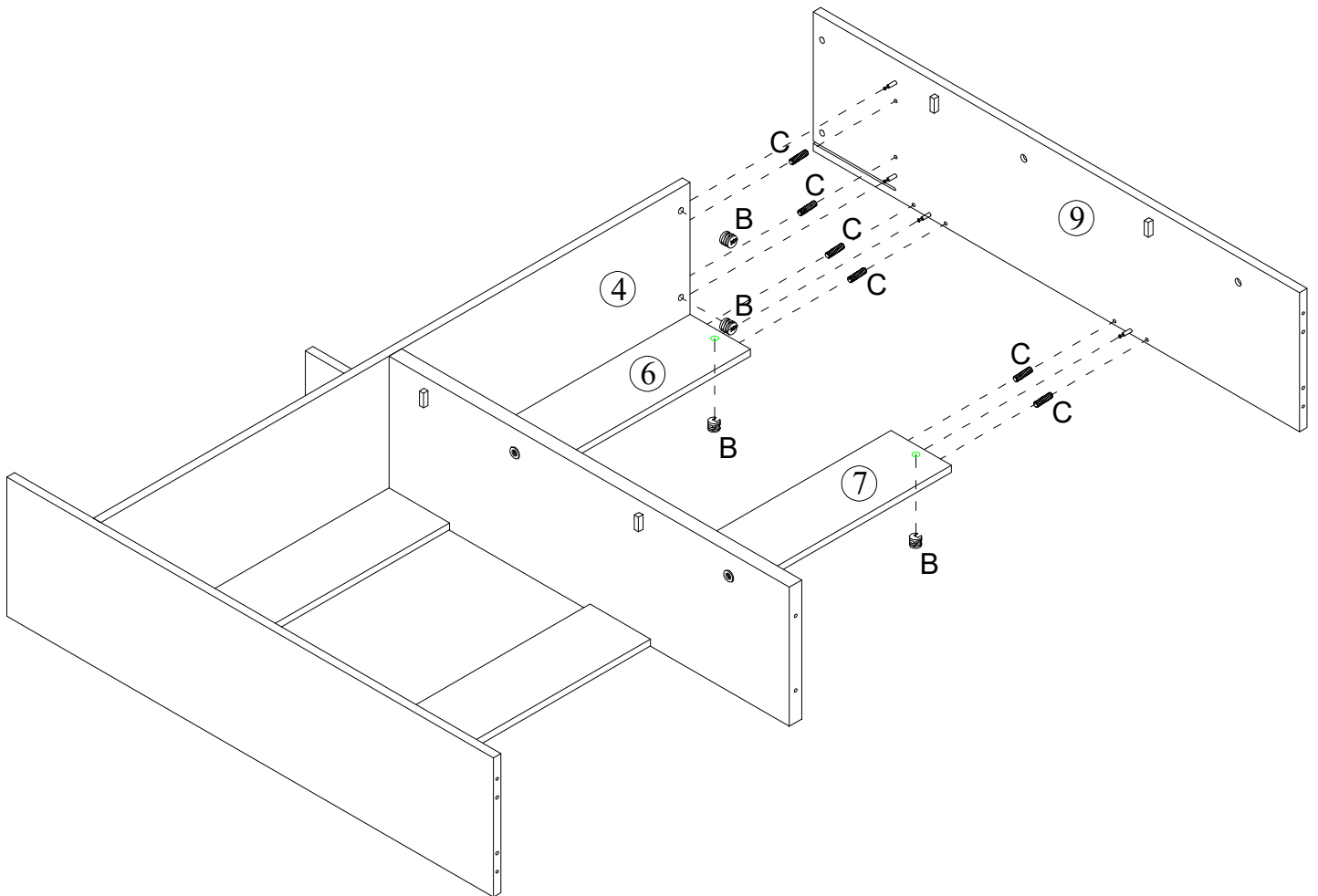
Connect panel (9) using wood dowel (C), and tighten with cam lock (B)



ASSEMBLY STEPS

C x 6	M6x30mm 	D x 6	M5x40mm 
-------	--	-------	--

STEP 16

Connect panel (10) to the assembled panel (5), (8), and (9) using wood dowel (C), and tighten with cam lock (B)

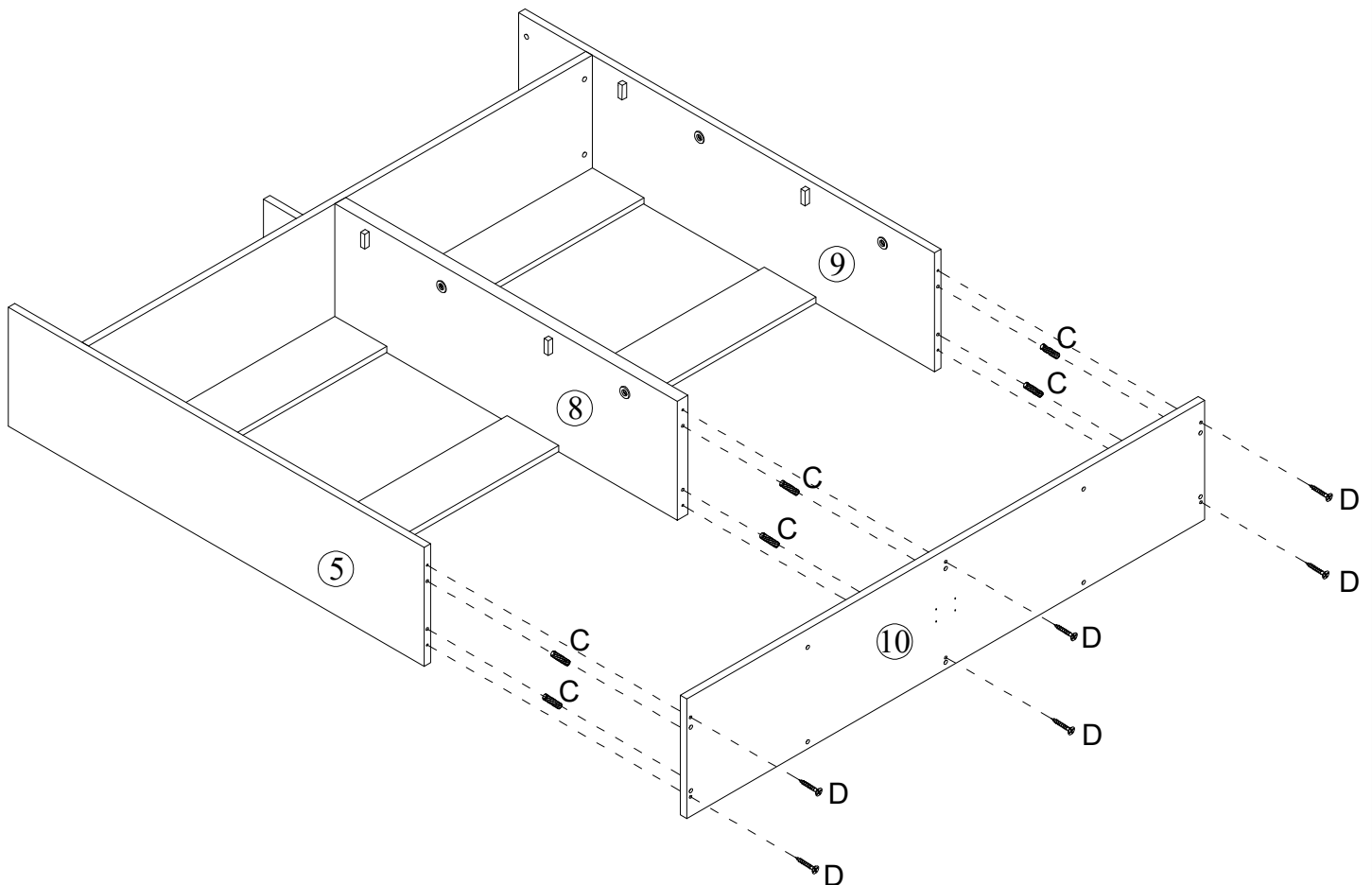

ASSEMBLY STEPS

I x 1



U x 6



STEP 17

Connect the side metal frame (11), upper metal strip (12), and bottom metal strip (13) using screw (J) and tighten with L-shaped wrench (I)

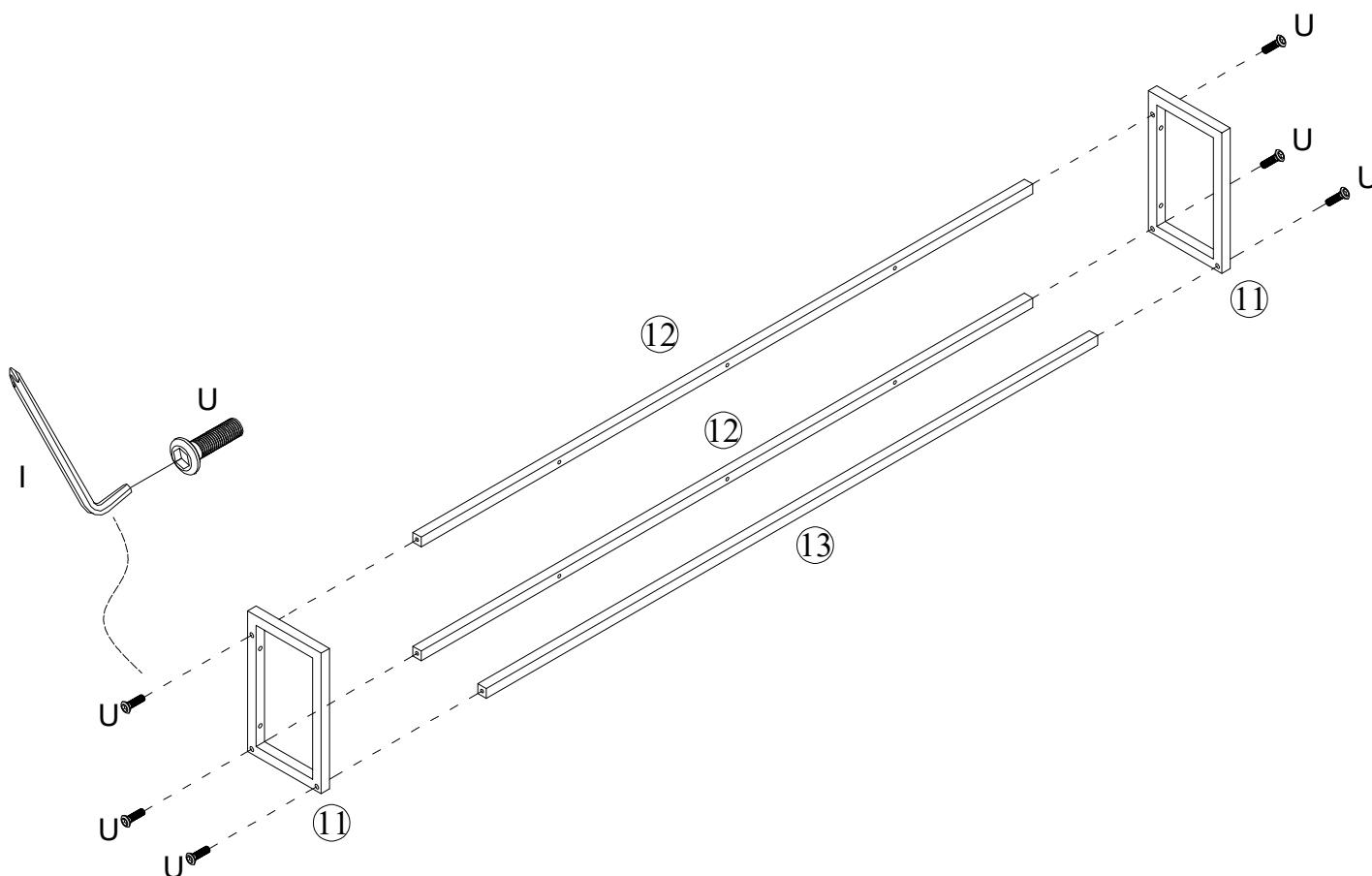

ASSEMBLY STEPS

I x 1



J x 10



STEP 18

Attach the assembled metal frame and metal strip (11) (12) and (13) to panel (10) using screw (J) and tighten with L-shaped wrench (I)

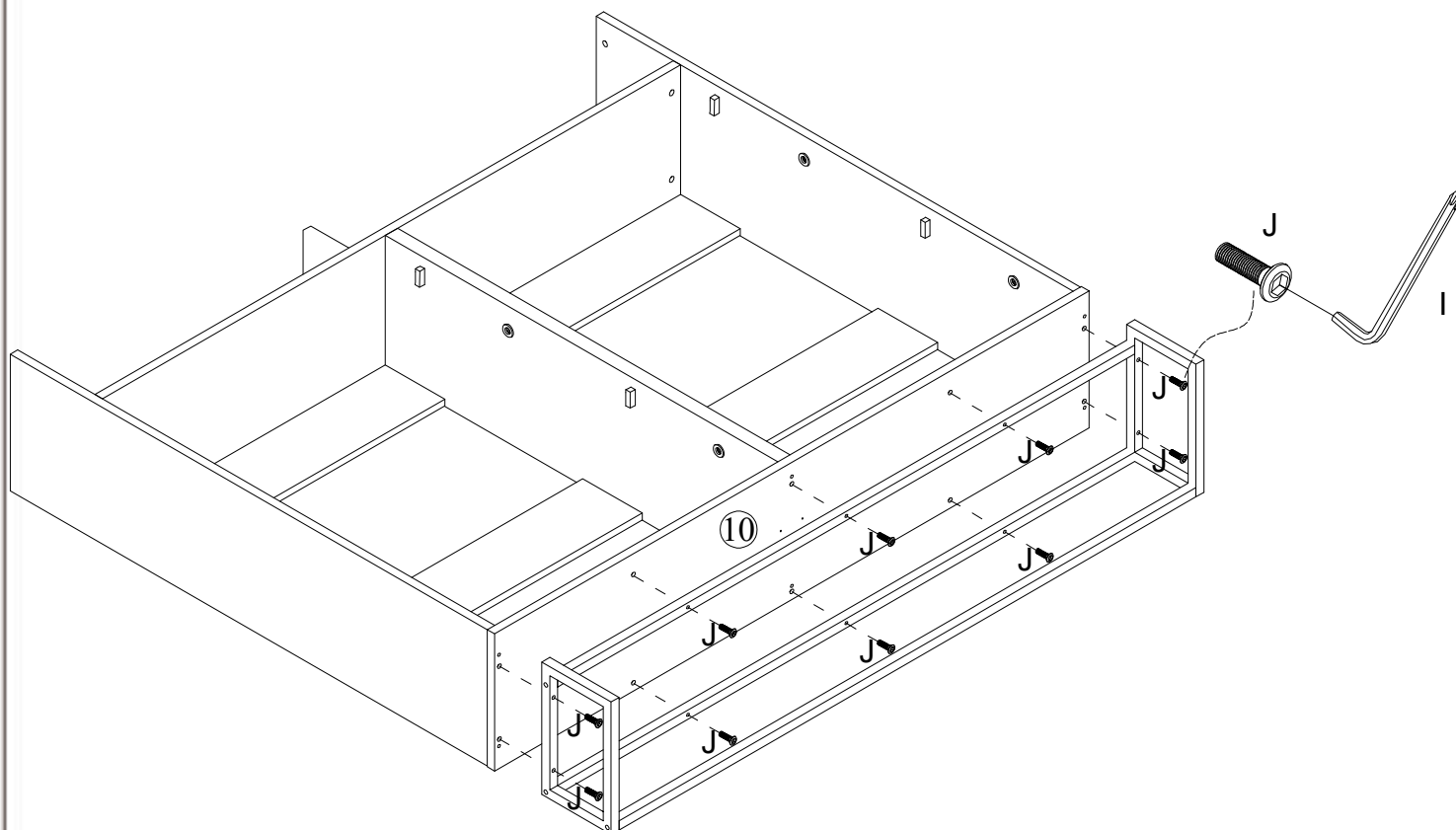

ASSEMBLY STEPS

H x 4		T x 4	M4x12mm 
-------	---	-------	---

STEP 19

1. Apply non-slip mat (H) to the bottom of the metal frame.
2. Secure metal supporting leg (14) to the bottom using screw (T)

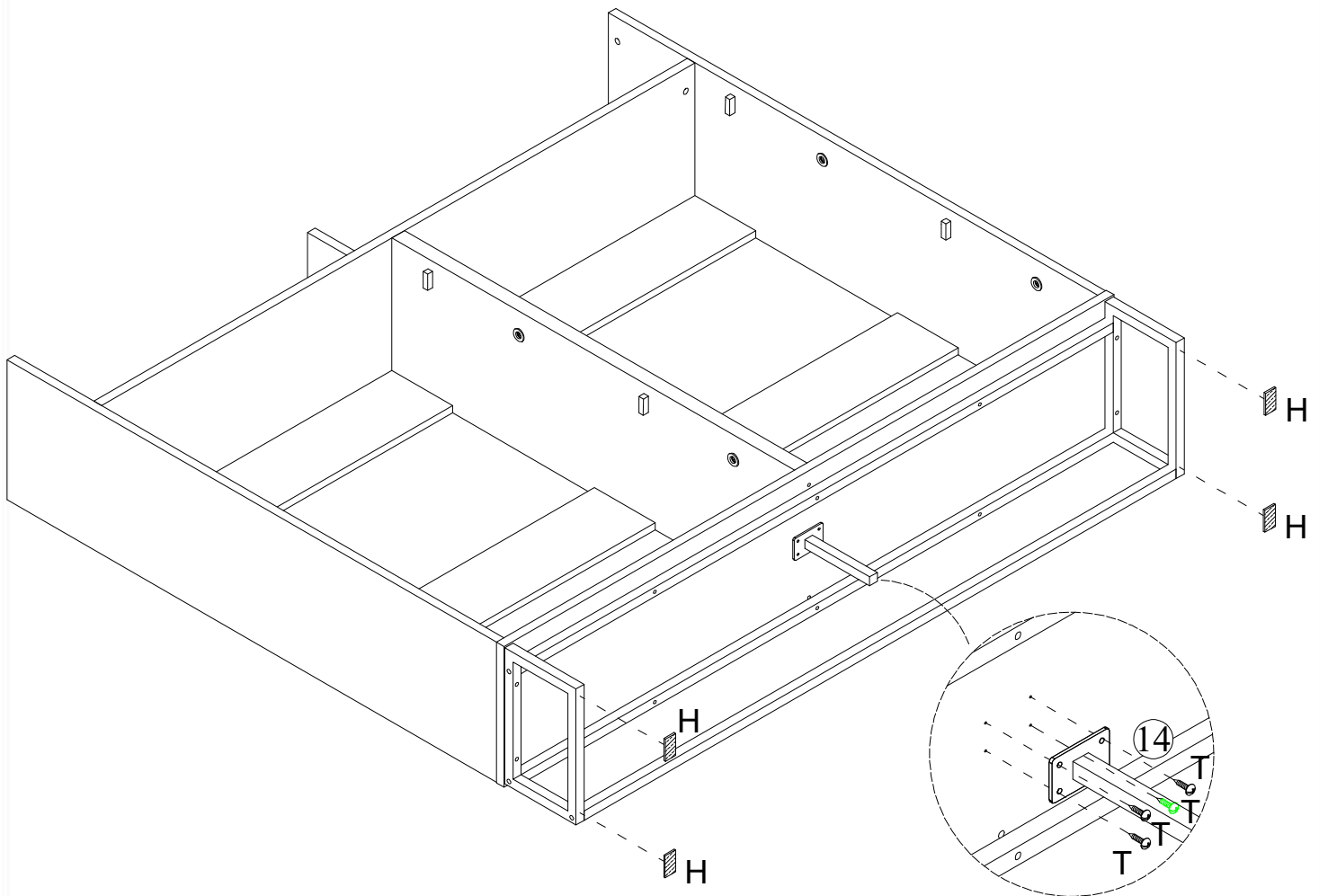



ASSEMBLY STEPS

STEP 20

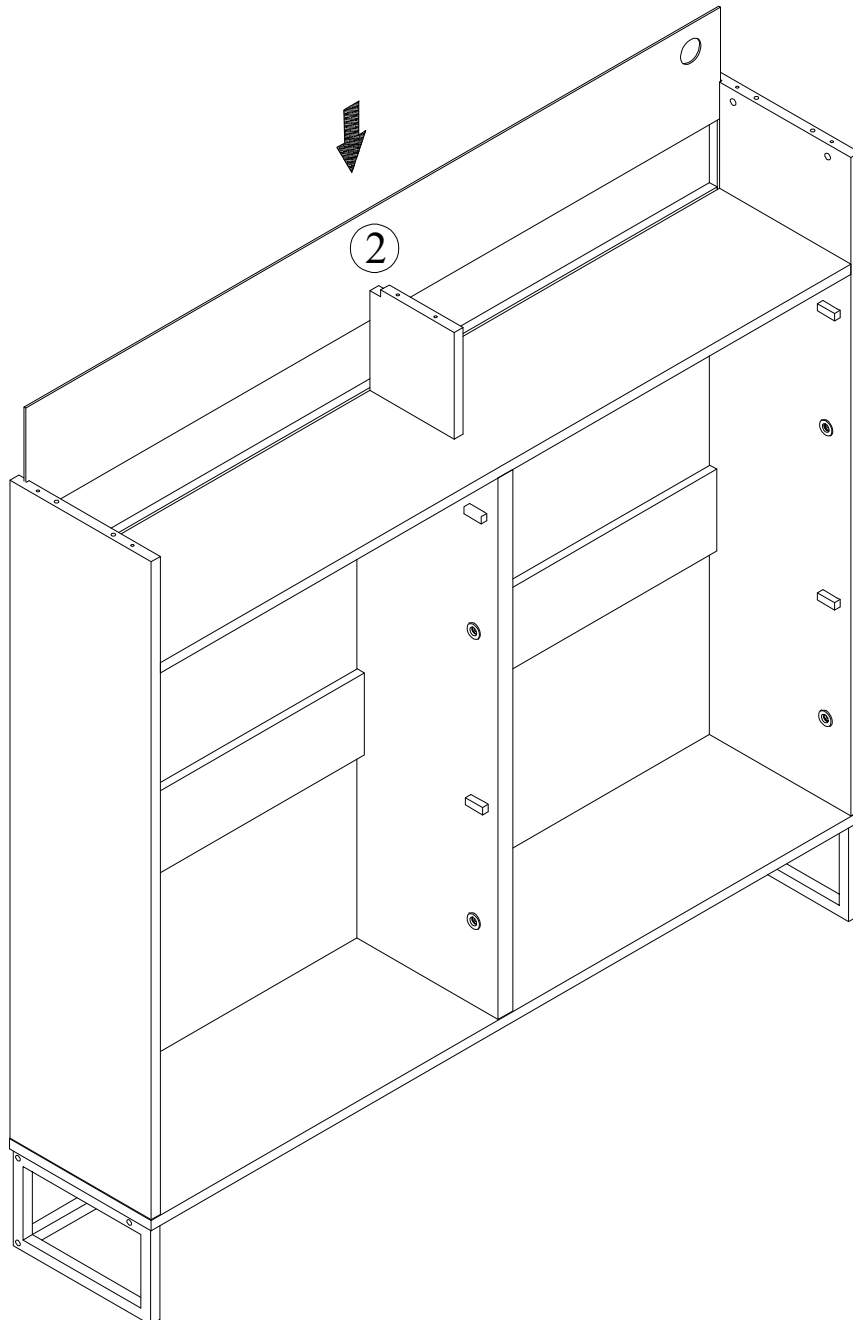
Insert panel (2) along the groove



ASSEMBLY STEPS

B x 6	M15x10mm 	C x 4	M6x30mm 	K x 6	
-------	---	-------	--	-------	--

STEP 21

1. Connect panel (1) to the cabinet body using wood dowel (C), and tighten with cam lock (B).
2. Cover the cam lock holes with hole cover sticker (K)

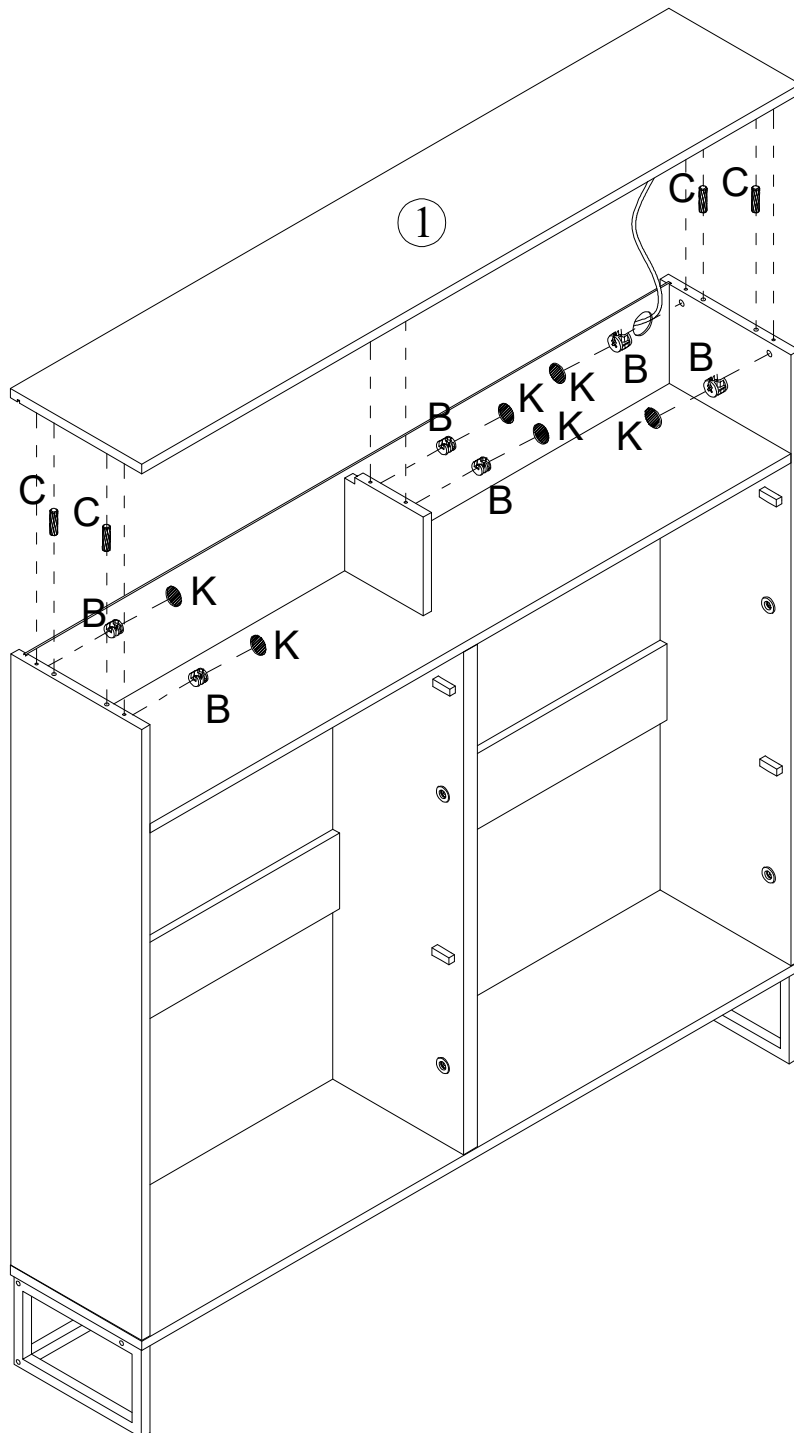

ASSEMBLY STEPS

S x 4

S-1



M3x16mm

S-2



STEP 22

Insert mending wedge (S-1) into the gap of the back panel and secure it with screw (S-2)

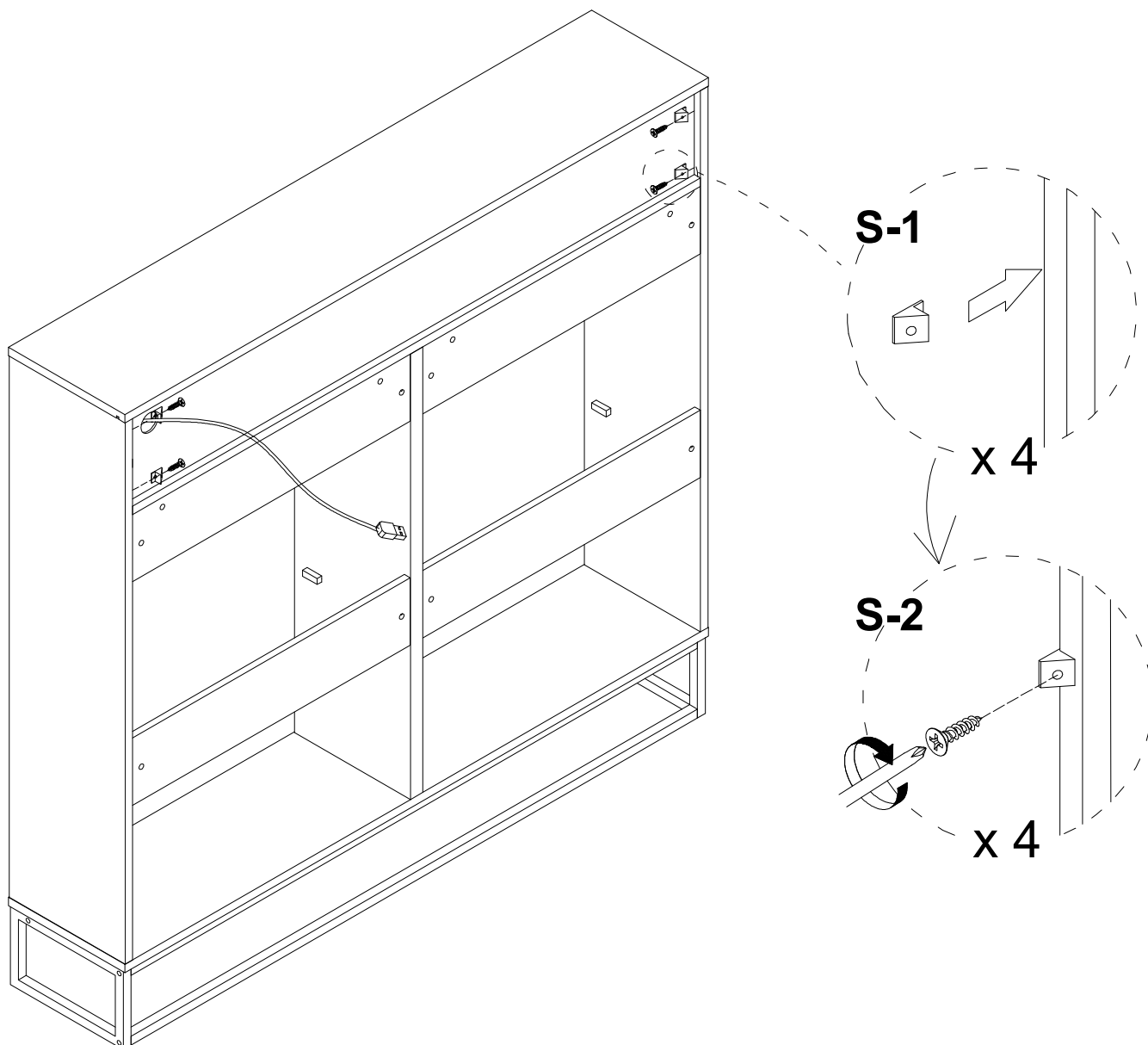

ASSEMBLY STEPS

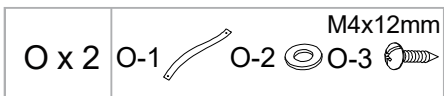

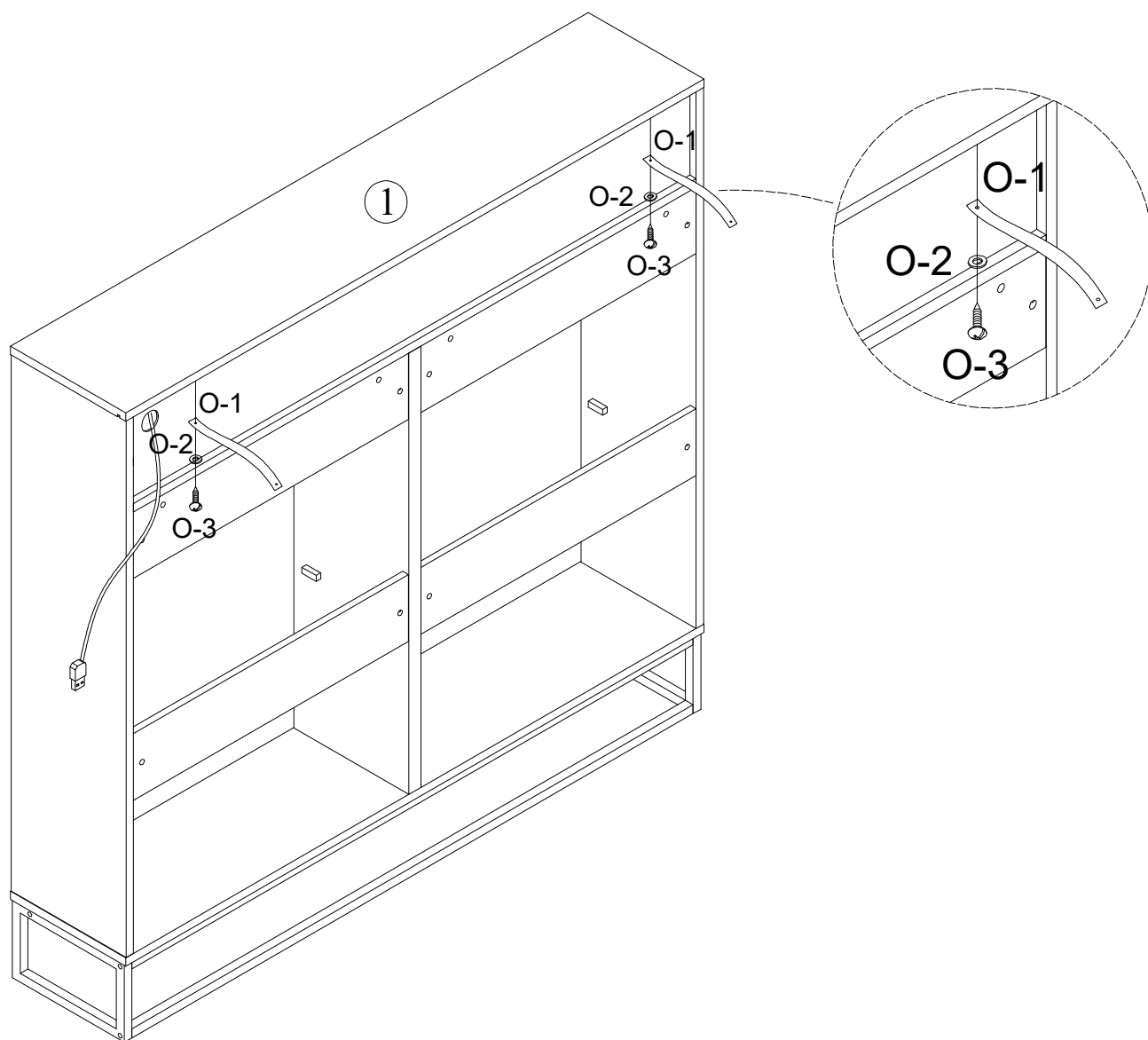

STEP 23

Use screw (O-3) to pass through washer (O-2) and fix the anti-tip strap (O-1) under panel (1)



ASSEMBLY STEPS

E x 8	M4x8mm 	M x 8	
-------	---	-------	---

STEP 24

Secure the assembled upper flip drawer front panel (19) and bottom flip drawer front panel (20) using screw (E) and accessory (M)

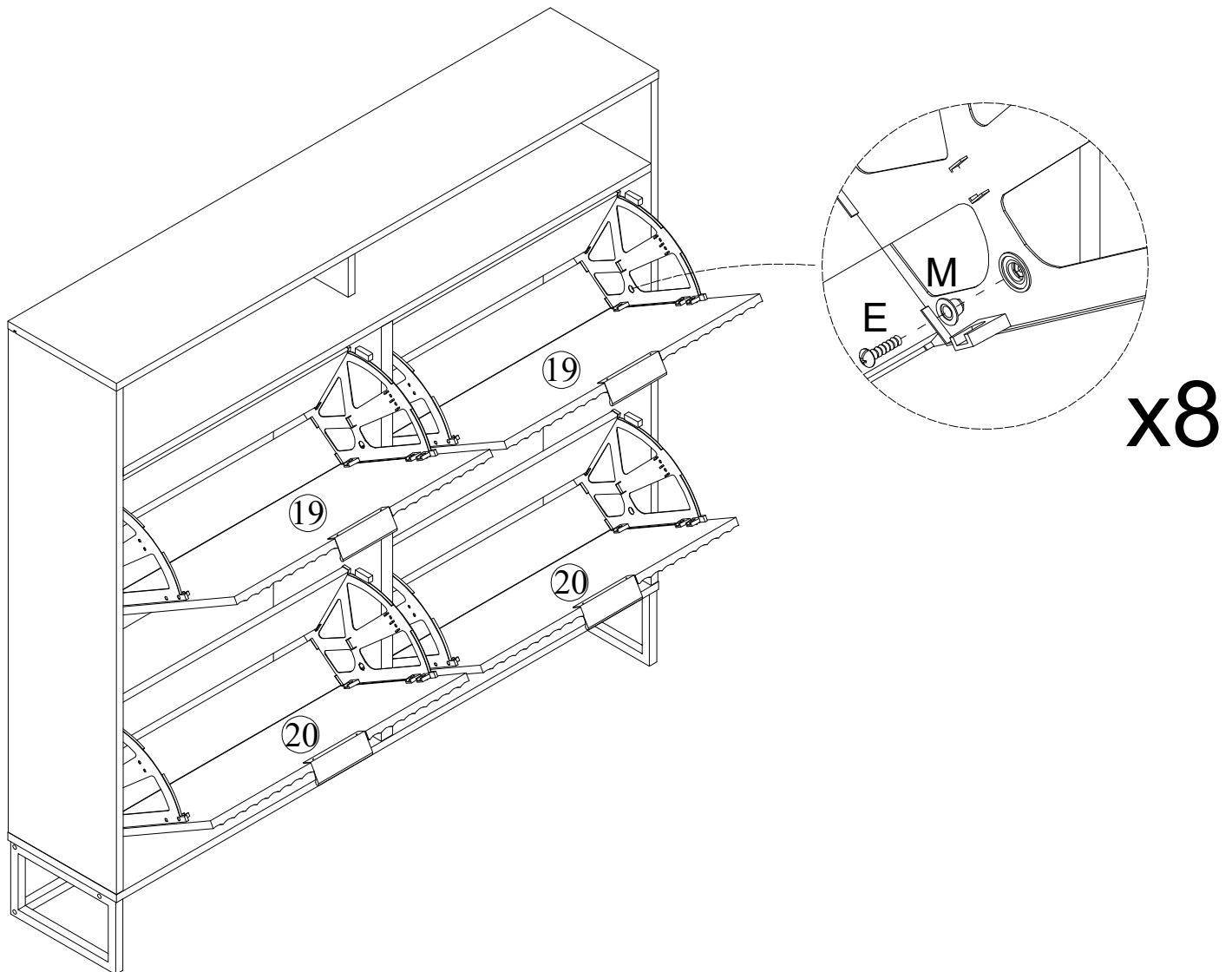

ASSEMBLY STEPS

F x 8

M3.5x14mm



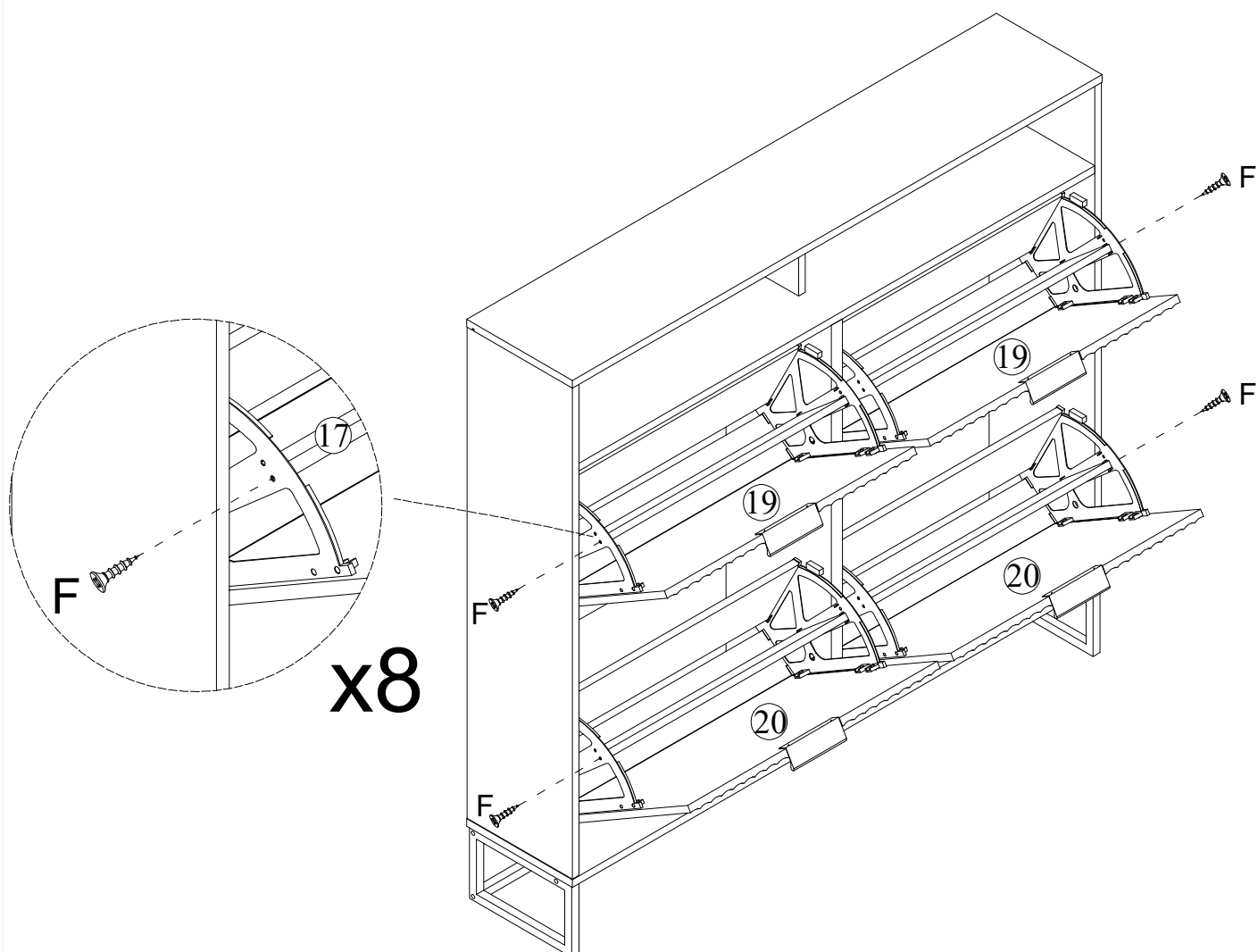

STEP 25

Use screw (F) to secure panel (17) to the swivel rack bracket (15) and (16)



ASSEMBLY STEPS

N x 2	N-1 	N-2 	N-3 	M4x45mm
-------	---	---	---	---------

STEP 26

1. Drill two holes in the wall.
2. Embed the plastic anchor (N-1) into them, and then use screw (N-3) to pass through washer (N-2) to fix it onto the wall

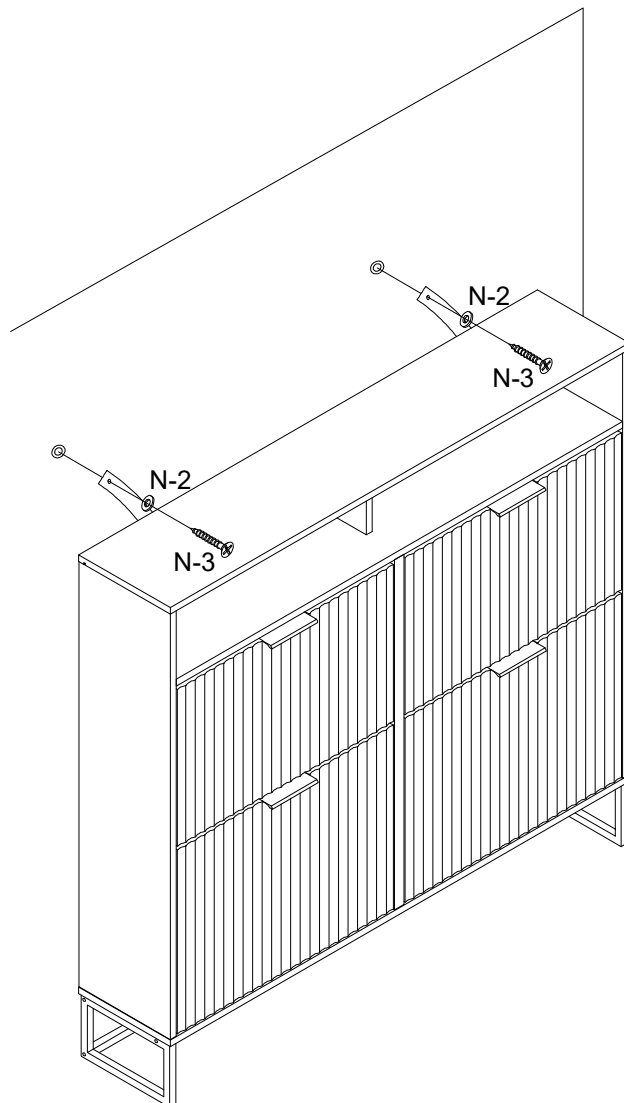
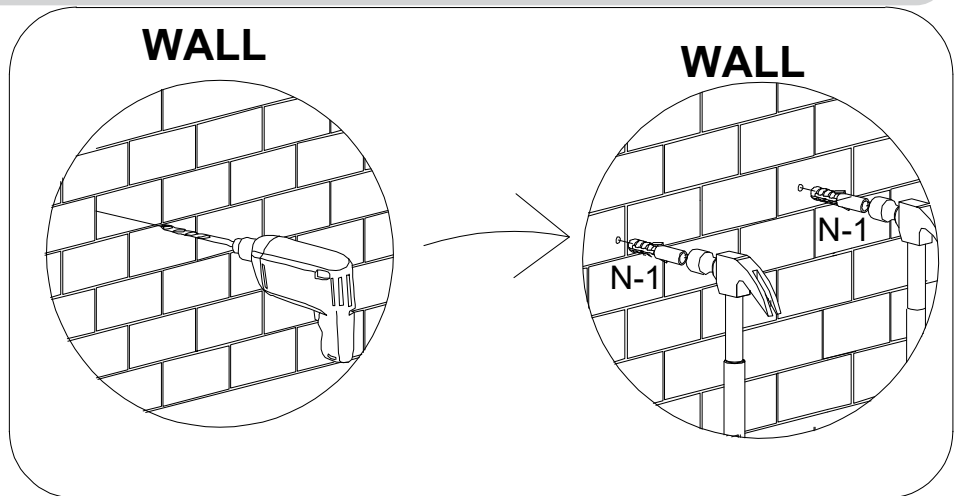

1. What should I do when I received a defected item?

Please feel free to contact VINGLI customer service via the link where you purchased this item with your order ID, pictures of the defective areas to us. We are eager to help you to make it right.

2. Is it easy to put the screws to the panels?

Yes. As long as you follow the instruction and use the correct screws and put it in correct holes, it is easy to screw it into pre-drilled holes.

3. What should I do if I have a problem with the drawers not closing flush?

The problem with the drawers not closing flush is usually caused by the assembly of the drawer slides. Here are the solutions as below:

1) Please check whether the slide rail is damaged, for example, the ball of the slide rail has fallen out, if so, please ask us for replacements of the drawer slides;

2) Refer to the assembly manual to check if the holes for the slide rail are assembled correctly. If there is no problem with the assembly, but the slide rail is stuck in the process of pushing in, please release the entire drawer as you did the first time you removed the drawer slides, and then push it back in again.

Any query, please contact us directly.

Supplementary Instructions for Safe Use

English

WARNING



Children have died from furniture tipover. To reduce the risk of furniture tipover:

- ALWAYS install tipover restraint provided.
- NEVER put a TV on this product.
- NEVER allow children to stand, climb or hang on drawers, doors, or shelves.
- NEVER open more than one drawer at a time.
- Place heaviest items in the lowest drawers.
- Do not defeat or remove the drawer interlock system.

This is a permanent label.

Do not remove!

French

ATTENTION



Des enfants sont morts du basculement des meubles. Pour réduire le risque de basculement des meubles:

- TOUJOURS installer la retenue de basculement fournie.
- NE JAMAIS mettre de téléviseur sur ce produit.
- NE JAMAIS permettre aux enfants de se tenir debout, de grimper, ou de s'accrocher à des tiroirs, des portes ou des étagères.
- N'ouvrez JAMAIS plus d'un tiroir à la fois.
- Placez les objets les plus lourds dans les tiroirs les plus bas.
- Ne désactivez pas et ne retirez pas le système de verrouillage du tiroir.

Ceci est une étiquette permanente.

Ne pas enlever!

German

WARNUNG



Kinder sind an einem Möbelkipp gestorben. So verringern Sie das Risiko eines Umkippen von Möbeln:

- Installieren Sie **IMMER** die mitgelieferte Kipprückhaltevorrichtung.
- Stellen Sie **NIEMALS** einen Fernseher an dieses Produkt.
- Lassen Sie Kinder **NIEMALS** an Schubladen, Türen oder Regalen stehen klettern oder hängen.
- Öffnen Sie **NIEMALS** mehr als eine Schublade gleichzeitig.
- Legen Sie schwerste Gegenstände in die untersten Schubladen.
- Besiegen oder entfernen Sie das Schubladenverriegelungssystem nicht.

Dies ist ein dauerhaftes Etikett.

Nicht entfernen!