

**STEP 1:**

Attach rocker bottoms to the side frames with two (A) screws each.

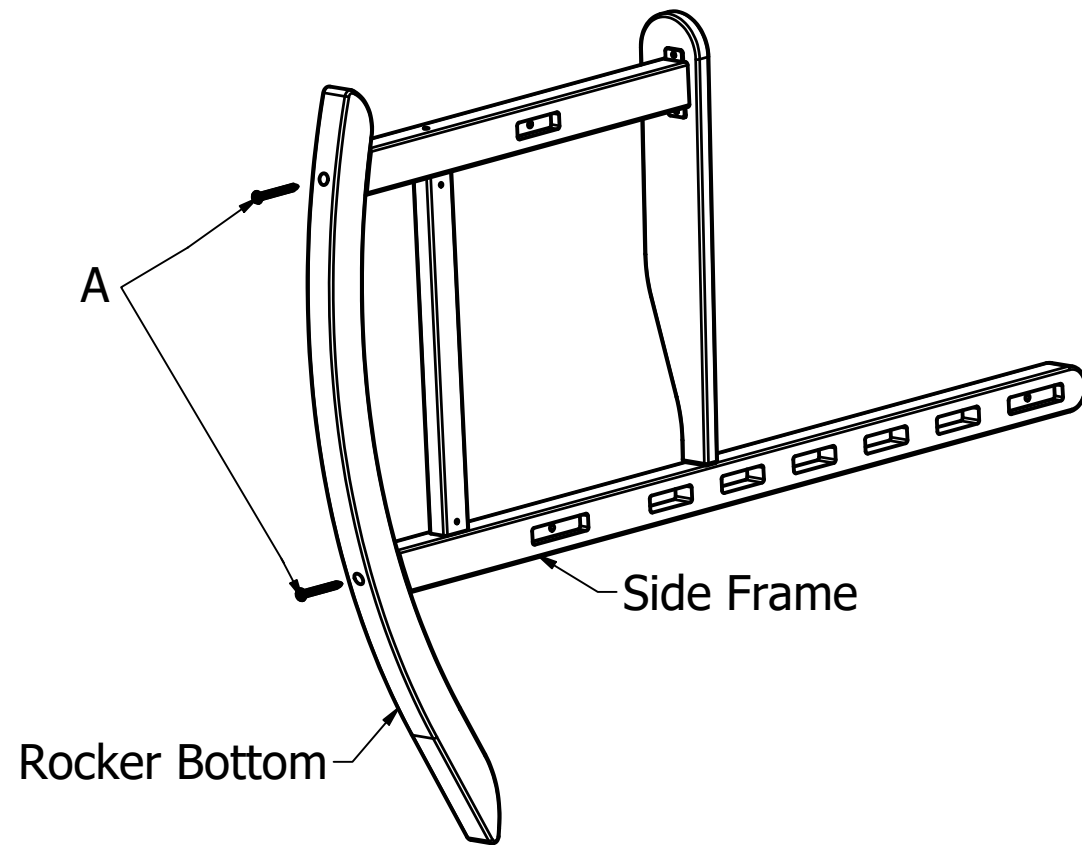

**STEP 2:**

Attach the head piece, back slats, seat frame, and side frame first by inserting each component then using three (A) screws to secure. A soft face mallet may be used to install slats into bottom of pockets.

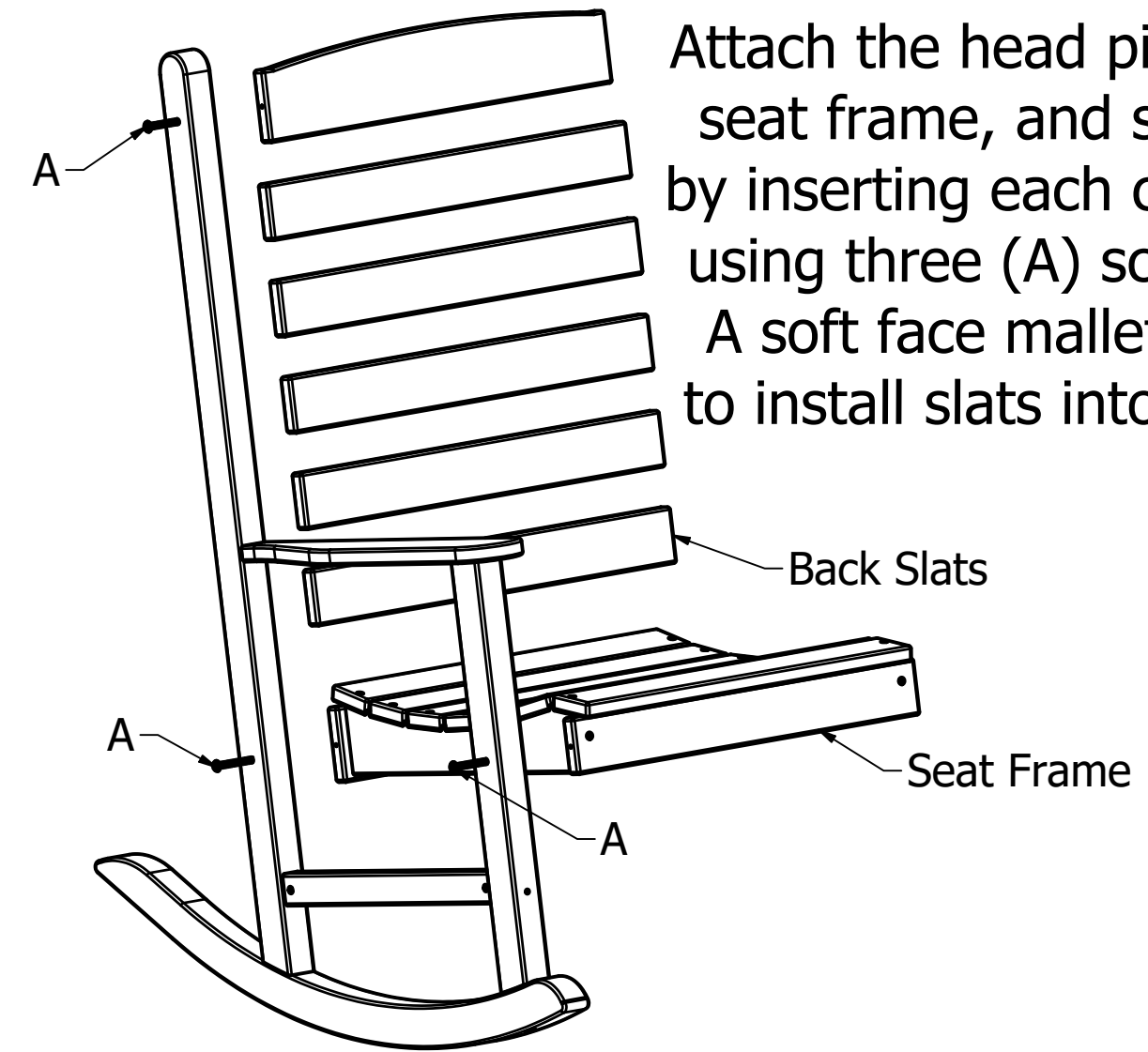

Parts List:

- (1) Hardware Pack
- (1) Head Piece
- (5) Back Slats
- (1) Seat Frame
- (2) Side Frame
- (1) Front Brace
- (1) Back Brace
- (2) Rocker Bottoms

TOOLS REQUIRED:

Allen Wrench - Included

Phillips Screw-Driver - Not Included

**STEP 3:**

Repeat Step 2 on the other side.

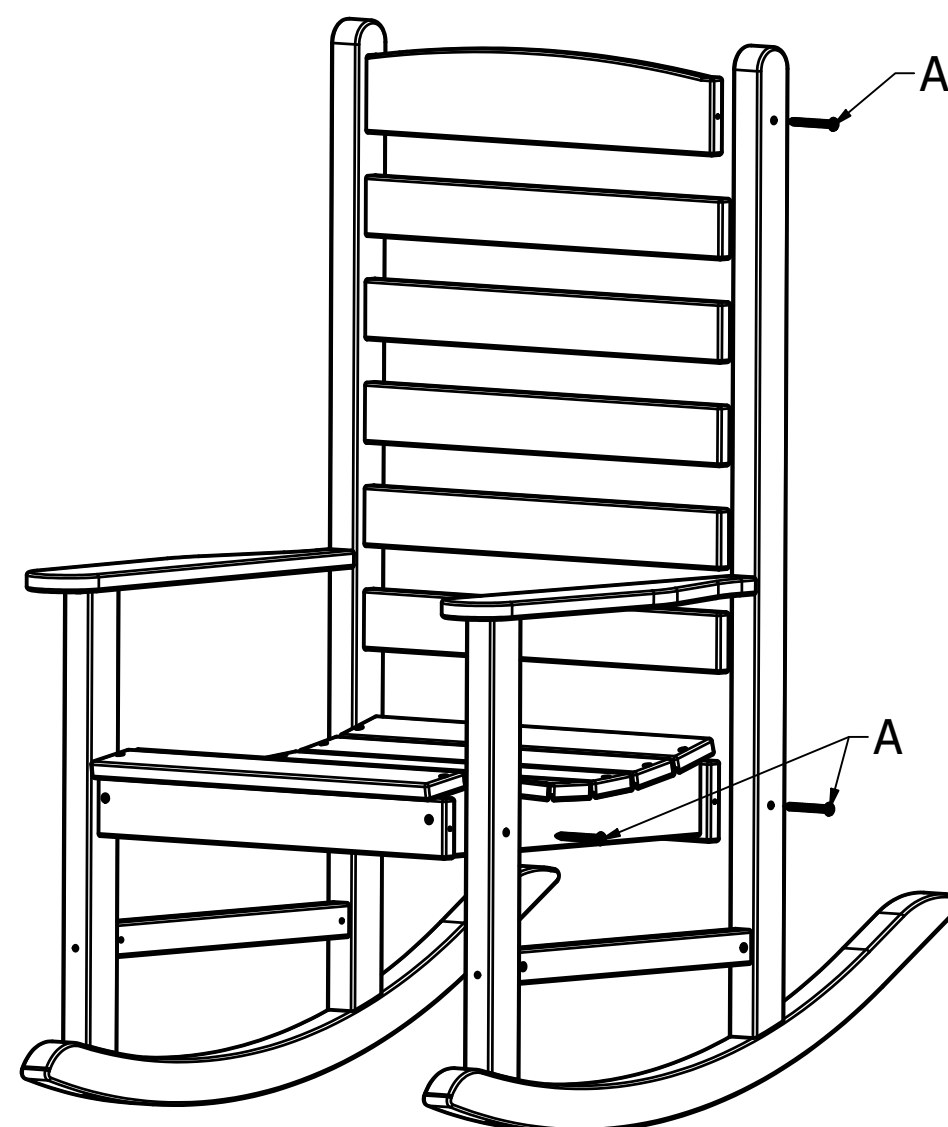

**STEP 4:**

Attach the front and back brace using four (B) screws.

Note: Back brace has the logo plate. Logo plate should be facing towards the back of the rocker.

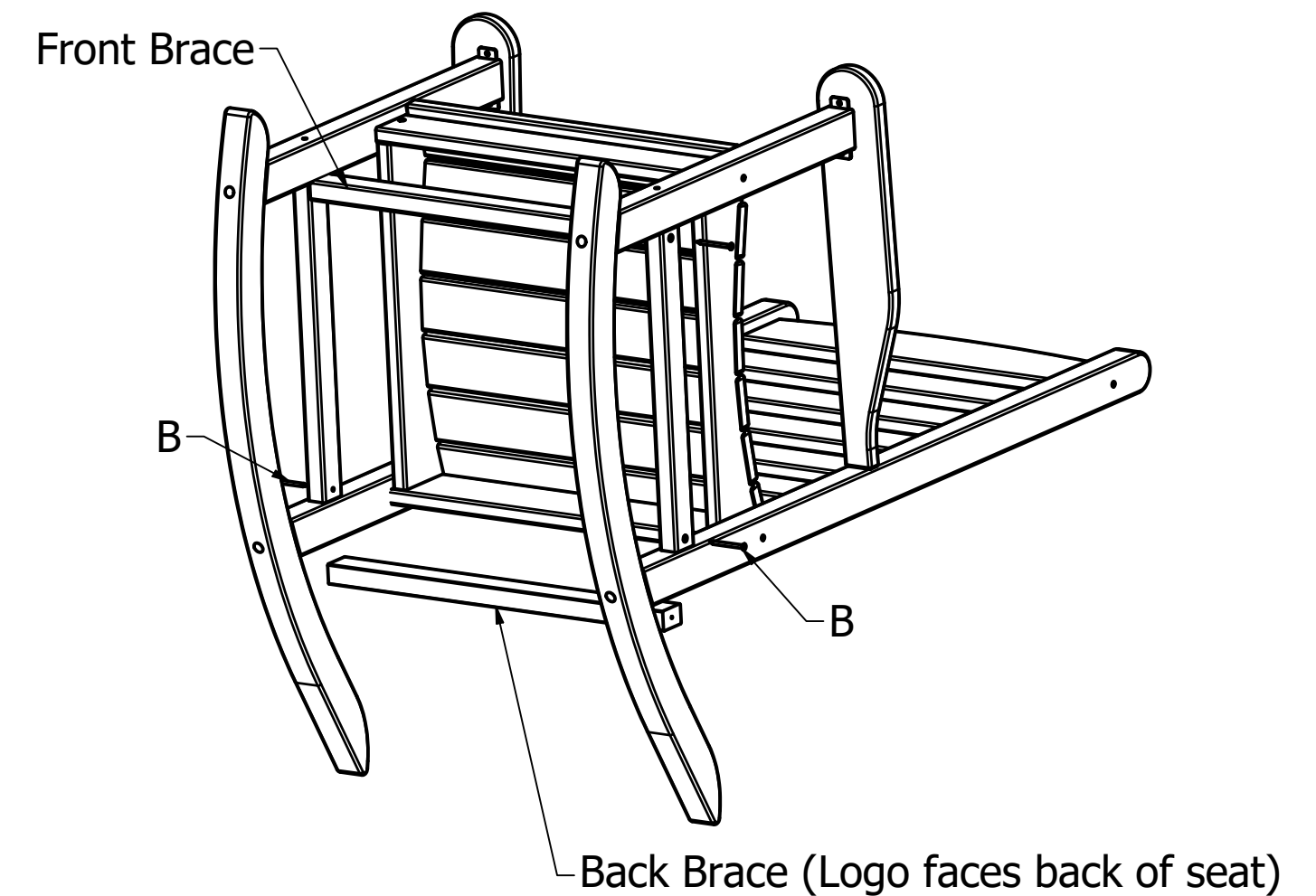

**NOTE: Do not use an impact driver to install hardware. Use battery operated drill or provided Allen wrench.**

(10) A - .273 x 2-1/2" Hex Screw

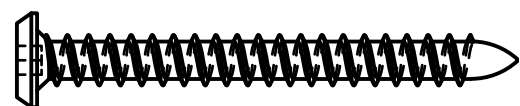

(4) B - 2" Phillips Screw

