

ASSEMBLY GUIDE
GUIDE D'ASSEMBLAGE
INSTRUCCIONES DE ENSAMBLAJE

72W Hutch
Huche 72L
Alacena 72An

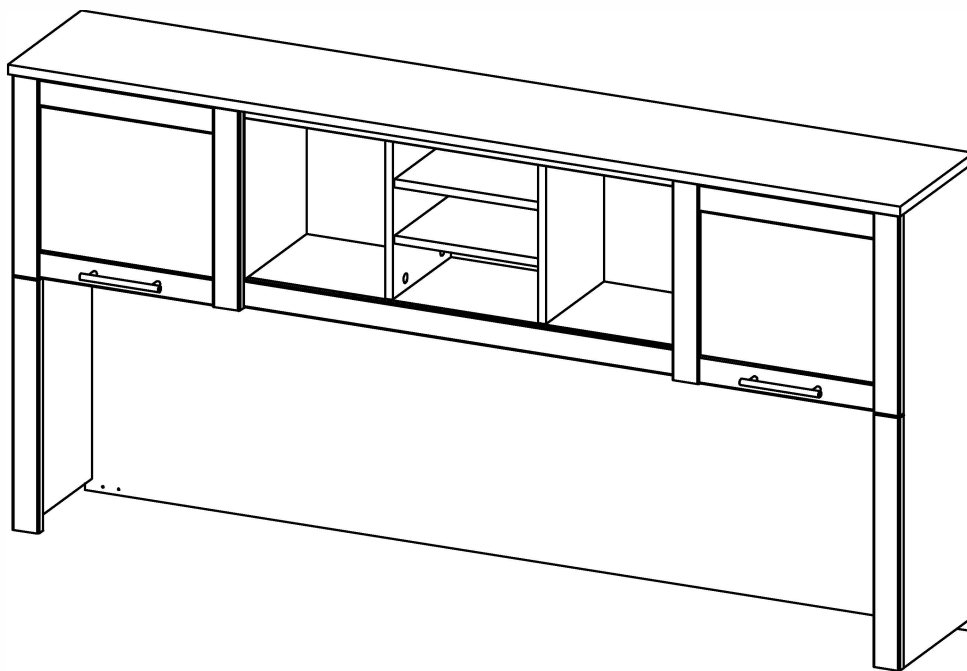

△ NOTE:

If there are parts missing from your order or if your product was damaged during shipping, PLEASE CONTACT US DIRECTLY.

△ NOTE :

S'il vous manque des pièces ou si votre meuble a été endommagé pendant le transport, VEUILLEZ NOUS CONTACTER DIRECTEMENT.

△ NOTA:

En caso de piezas faltantes o si su producto fue dañado durante el envío, POR FAVOR CONTACTENOS DIRECTAMENTE.

KEEP MANUAL FOR FUTURE REFERENCE. | CONSERVEZ LE MANUEL POUR RÉFÉRENCE FUTURE. | GUARDE EL MANUAL PARA REFERENCIA FUTURA.

PART NUMBER | NUMÉRO DE PIÈCE | NÚMERO DE PIEZA: A177872G

LOT CODE | NUMÉRO DE LOT | CÓDIGO DE LOTE:

IMPORTANT SAFETY INFORMATION



PLEASE READ WARNINGS

Improper use can cause safety hazards, or damage to your furniture and household items.

Warning	Do	Don't	Why it's important
Serious injury may occur.	<ul style="list-style-type: none">Assemble following all instructions using all indicated parts and hardware provided.Attach hutch only as described in the instructions.Verify furniture is stable on it's own.Only place against a permanent wall structure at least as tall as the hutch or place back-to-back with hutch of same size.	<ul style="list-style-type: none">Do not move unit when loaded.Do not load with a television or other heavy equipment.Do not exceed the maximum load limits stated in the instructions.Do not allow children to climb, or hang on furniture.	Improper assembly, use or loading can lead to product instability, tipover, or collapse.

Advertencia	Hacer	No	Por qué es importante
Pueden producirse lesiones graves.	<ul style="list-style-type: none">Realice el montaje siguiendo todas las instrucciones y utilizando todas las piezas indicadas y los herrajes suministrados.Fije la conejera como se describe en las instrucciones.Compruebe que el mueble sea estable por sí mismo.Colóque el producto únicamente contra una estructura de pared permanente y fijelo directamente a los montantes de la pared siguiendo las instrucciones.	<ul style="list-style-type: none">No mueva la unidad cuando esté cargada.No cargue el mueble con un televisor u otro equipo pesado.No supere los límites máximos de carga indicados en las instrucciones.No permita que los niños trepen o se cuelguen de los muebles.	El montaje, uso o carga inadecuados pueden provocar inestabilidad, vuelco o colapso del producto.

IMPORTANT SAFETY INFORMATION



PLEASE READ WARNINGS

Improper use can cause safety hazards, or damage to your furniture and household items.

Avertissement	À faire	À ne pas faire	Pourquoi c'est important
Peut entraîner des blessures graves.	<ul style="list-style-type: none">• Assembler en suivant toutes les instructions et en utilisant toutes les pièces et la quincaillerie incluses.• Fixez la huche conformément aux instructions.• Assurez-vous que le meuble soit stable par lui-même.• Placer uniquement contre une structure murale permanente et fixer directement aux montants du mur selon les instructions.	<ul style="list-style-type: none">• Ne pas déplacer le meuble lorsqu'il est chargé.• Ne pas charger le meuble avec un téléviseur ou tout autre équipement lourd.• Ne pas dépasser les limites de poids maximales indiquées dans les instructions.• Ne pas laisser les enfants grimper ou s'accrocher aux meubles.	Un assemblage, une utilisation ou un chargement incorrects peuvent entraîner l'instabilité, le basculement ou l'effondrement du produit.

Parts - Pièces - Piezas

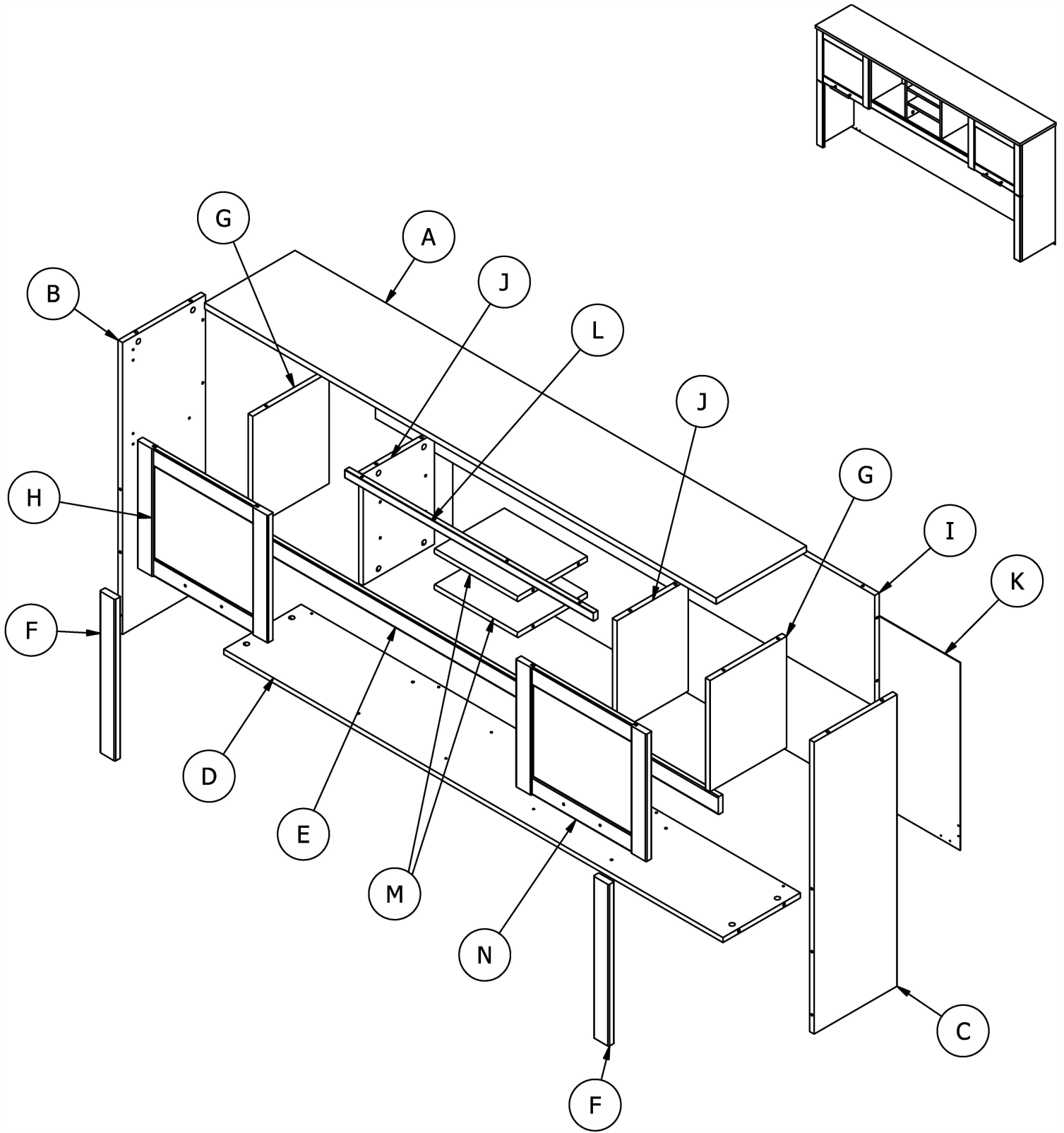

Fasteners - Fixations - Sujetadores

H23480  [4]
#8-32 x 7/8"

H72988  [21]

H27771  [35]
1/4 x 1

H181468US  [21]

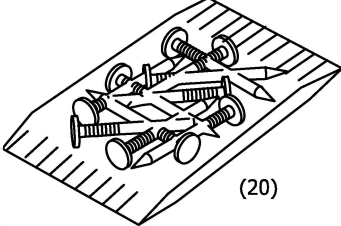
Q85389  [1]
(20)

H43507  [12]
#8 x 1/2"

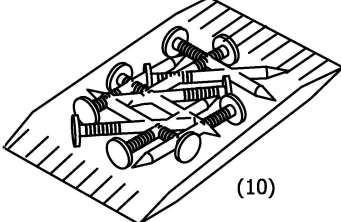
Q75494  [1]
(10)

H23682  [8]
#10 x 1"

Hardware - Quincaillerie - Quincaillas

Not to Scale - No a escala - Pas à l'échelle.

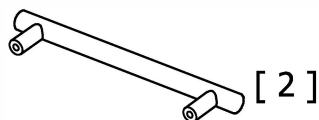
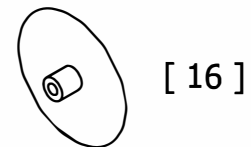
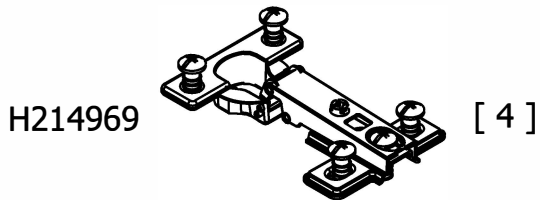
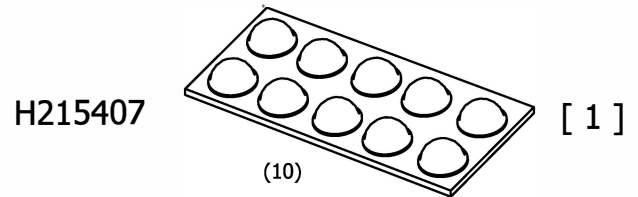
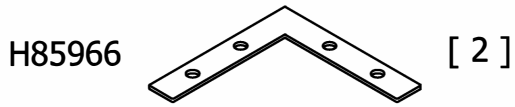

TIPOVER RESTRAINT HARDWARE

SUGERENCIA SOBRE HARDWARE DE RETENCIÓN

MATÉRIEL DE RETENUE SUR LE SUPPORT

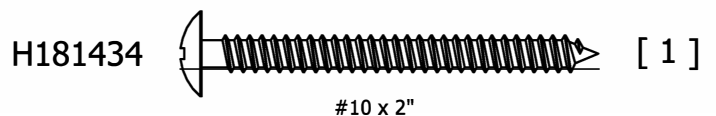
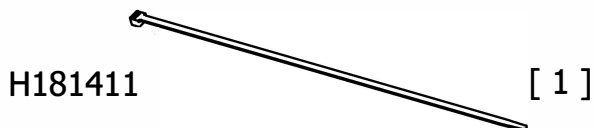
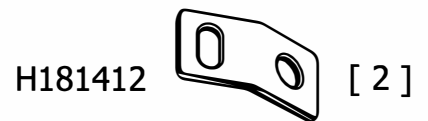
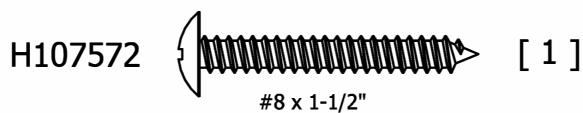

© 2014 American International Paper Company. All rights reserved. For more information, visit www.aip.com.

© 2014 American International Paper Company. All rights reserved. For more information, visit www.aip.com.

© 2014 American International Paper Company. All rights reserved. For more information, visit www.aip.com.

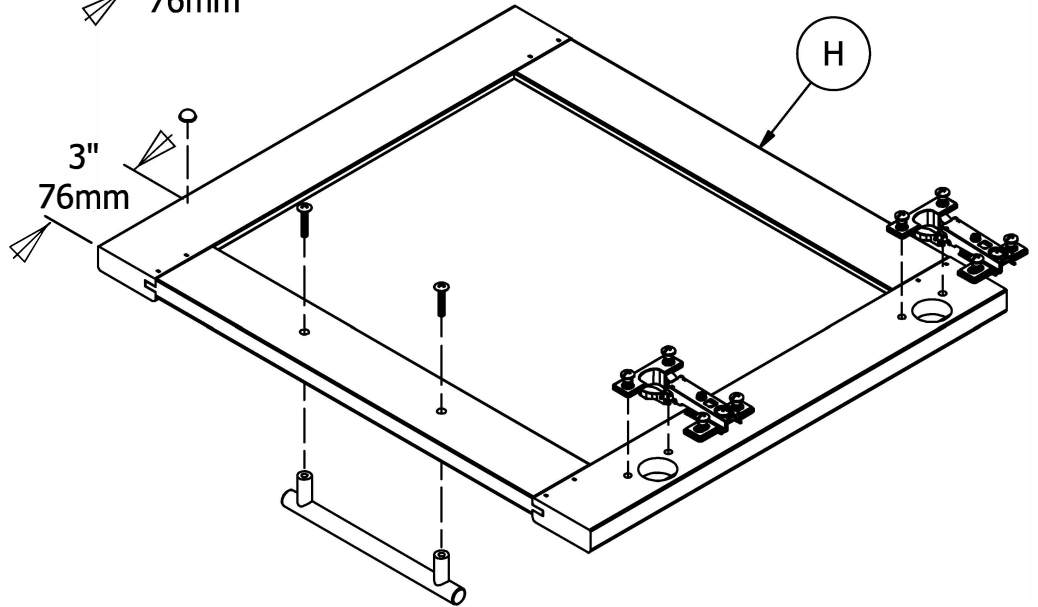
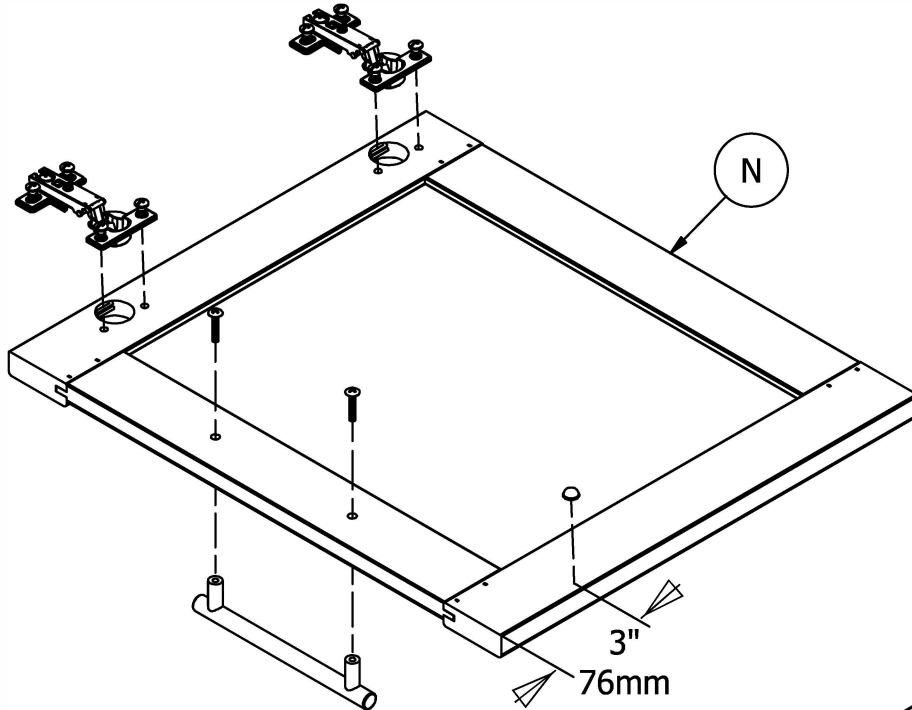
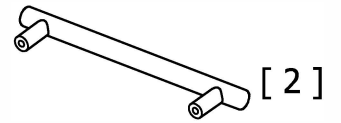
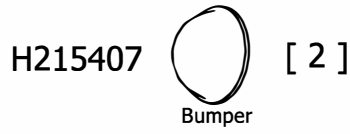
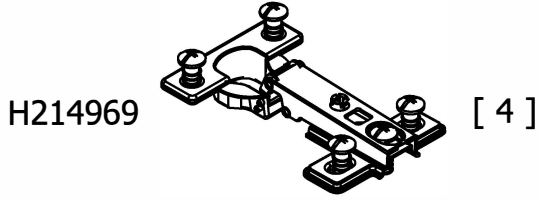

H72988  [9]

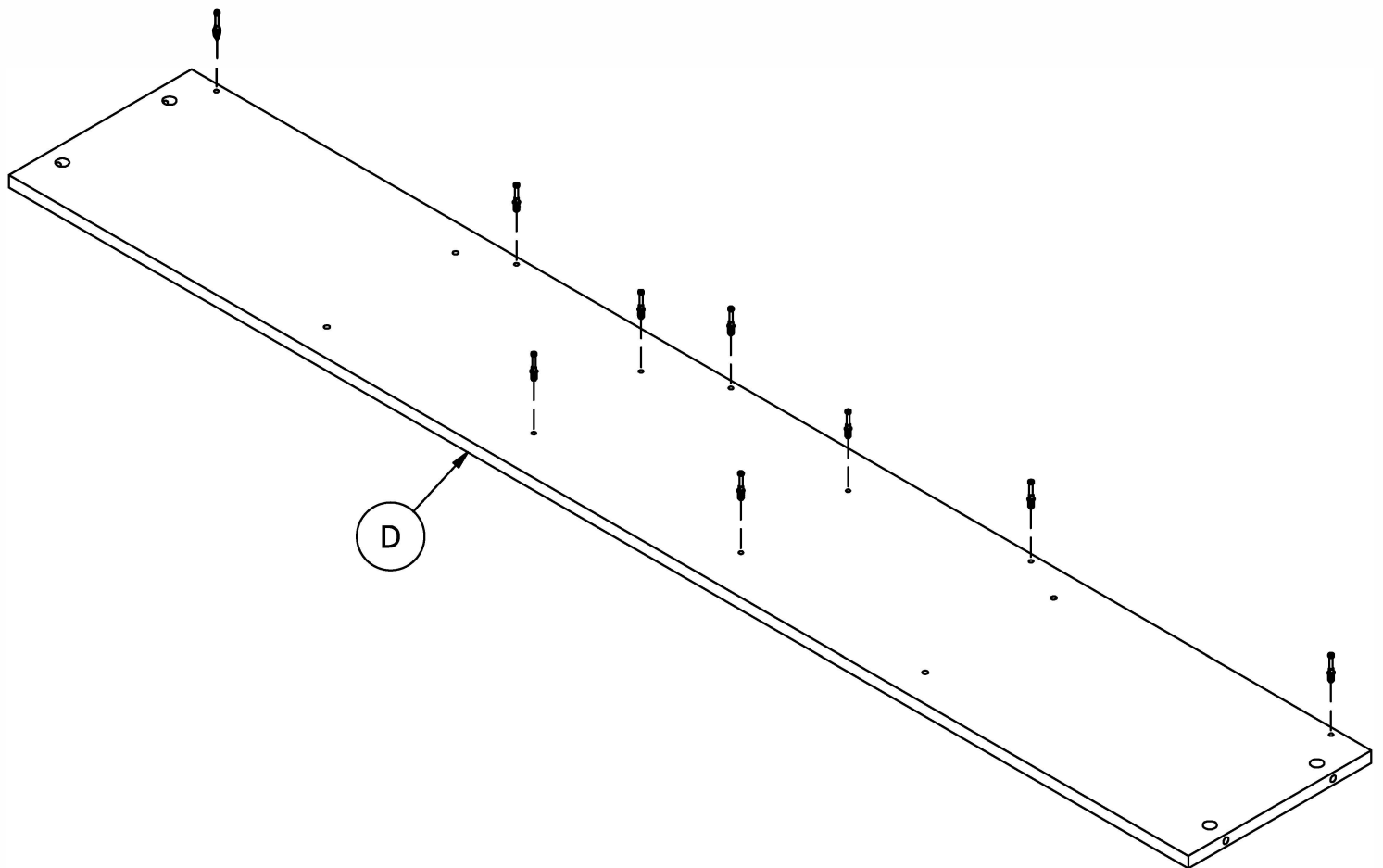
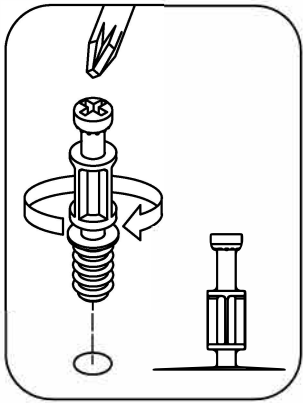

H27771

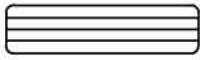

1/4 x 1

[9]

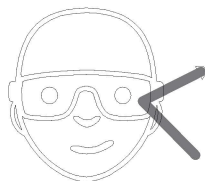
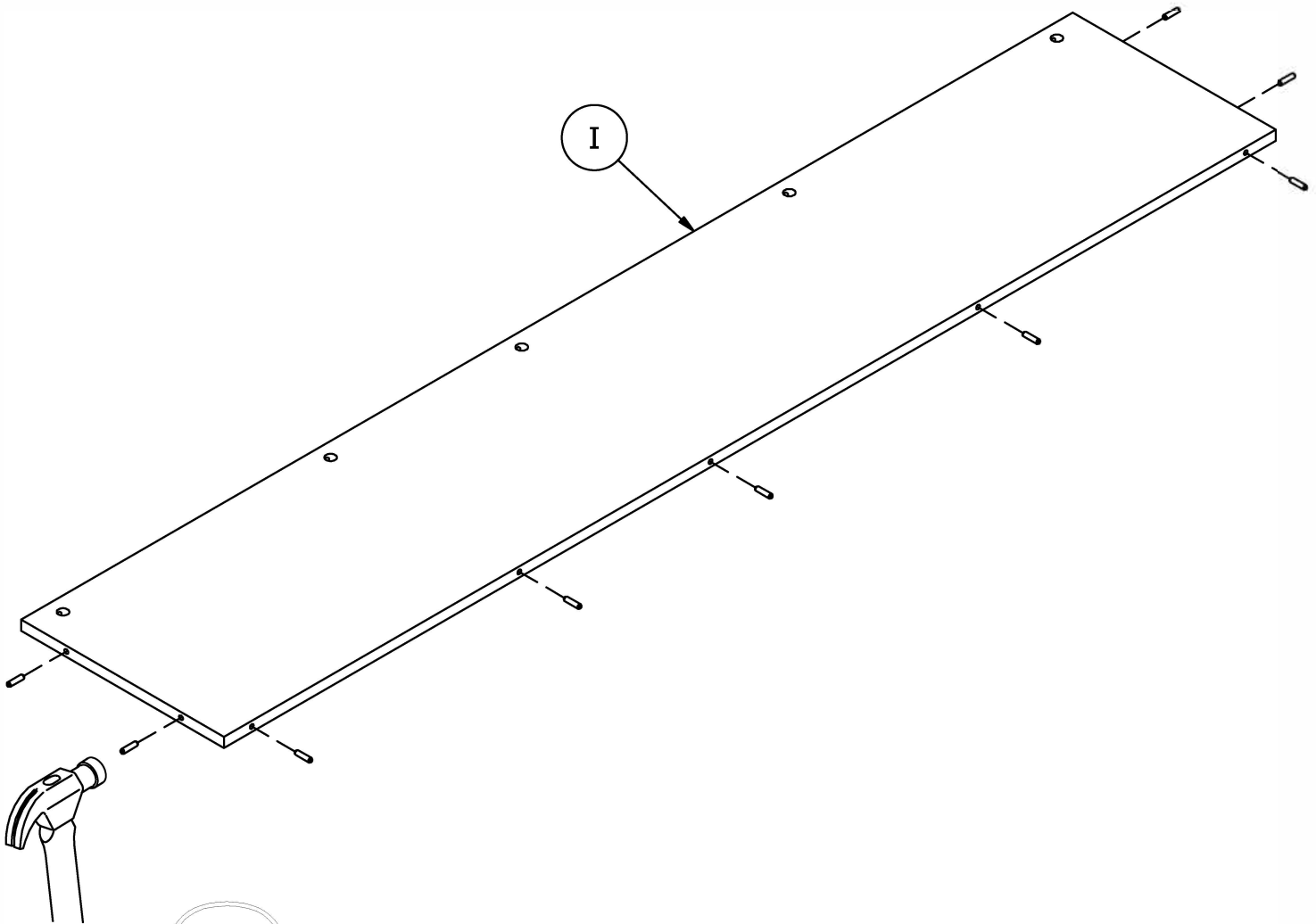



Safety glasses
Gafas de seguridad
Lunettes de protection

H181468US

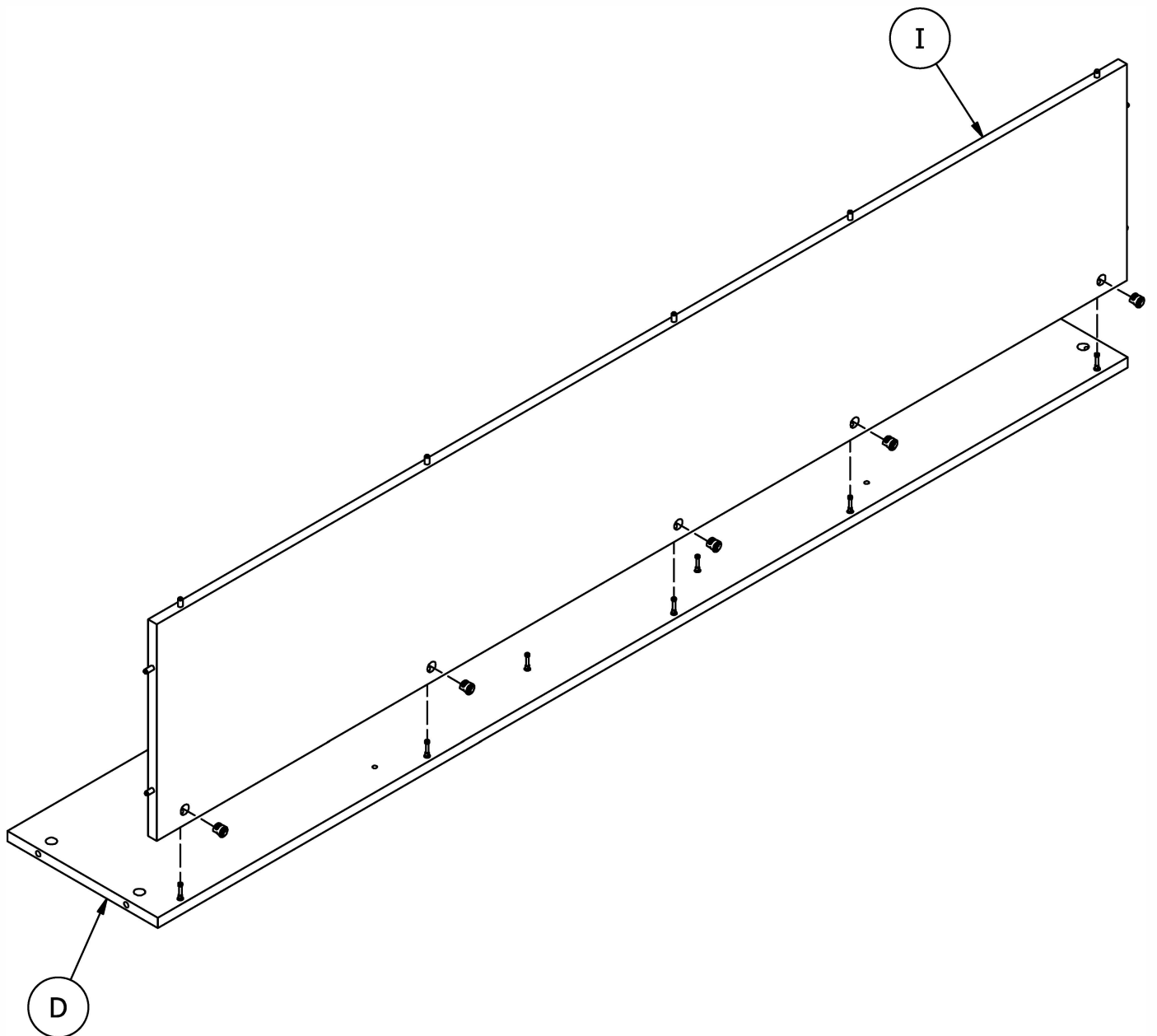
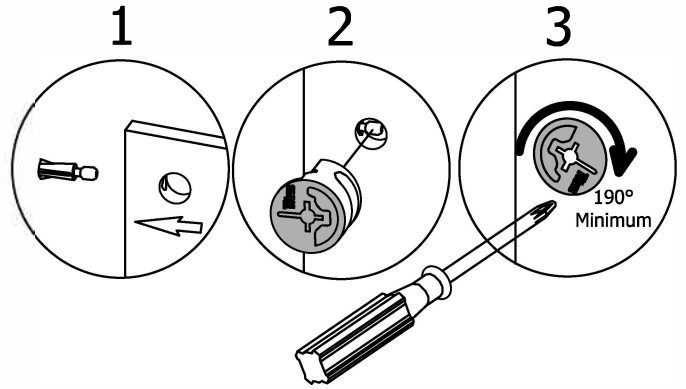

[5]

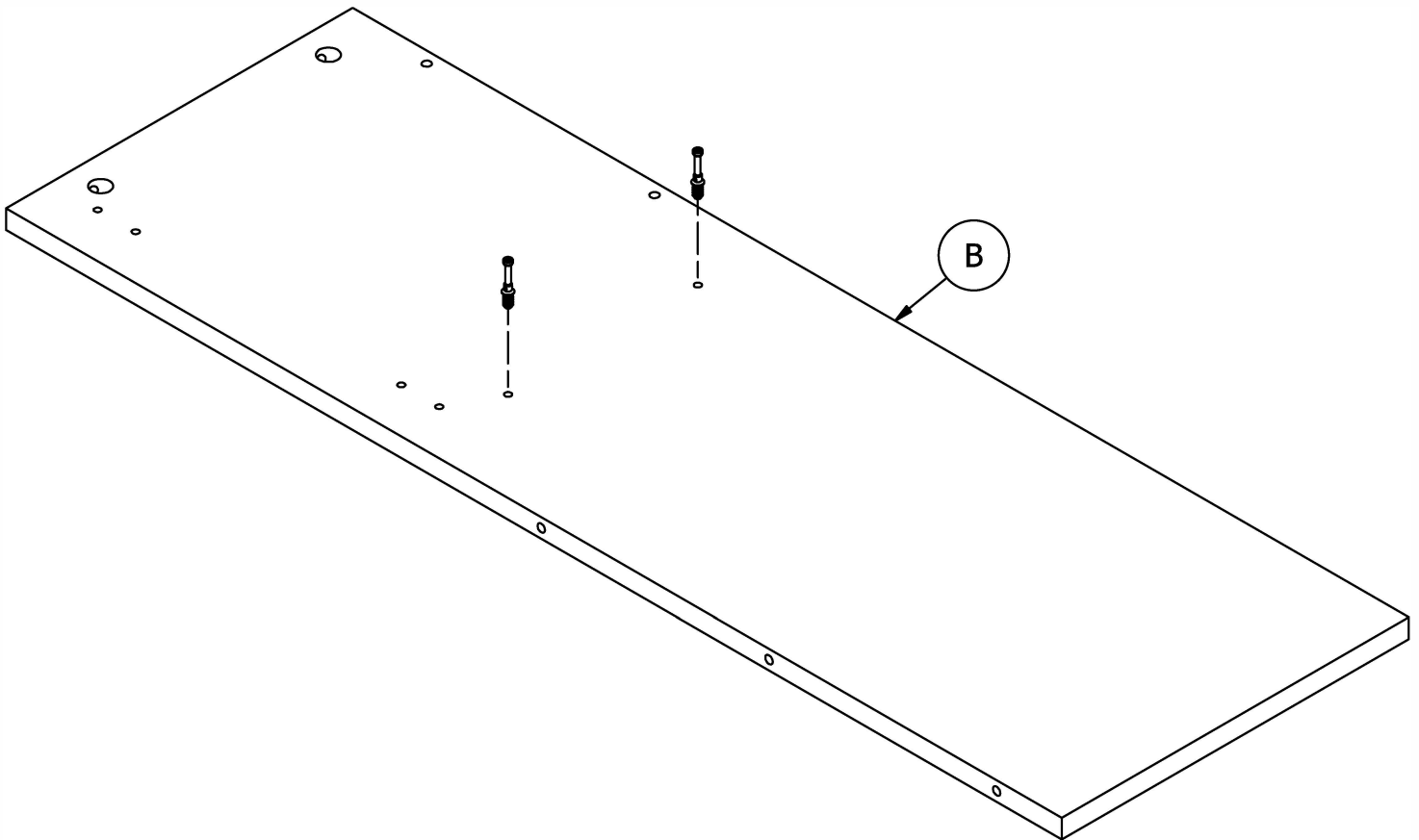
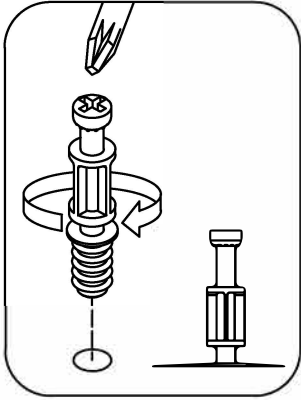

H72988  [2]

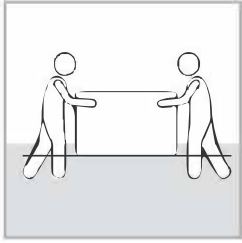

Team Lift
Esfuerzo de equipo
Effort d'équipe

H181468US



[2]

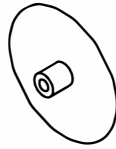

[2]

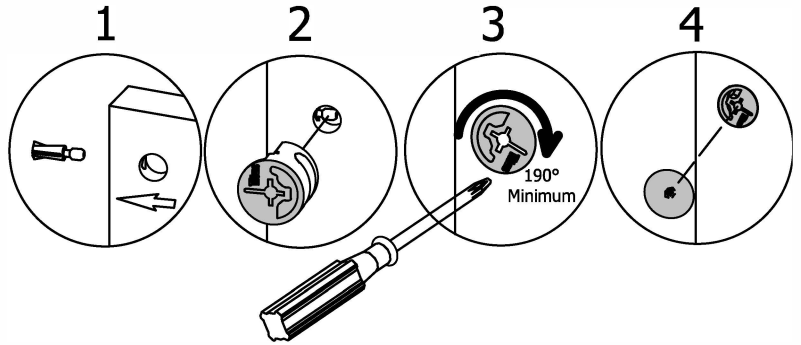

H27145

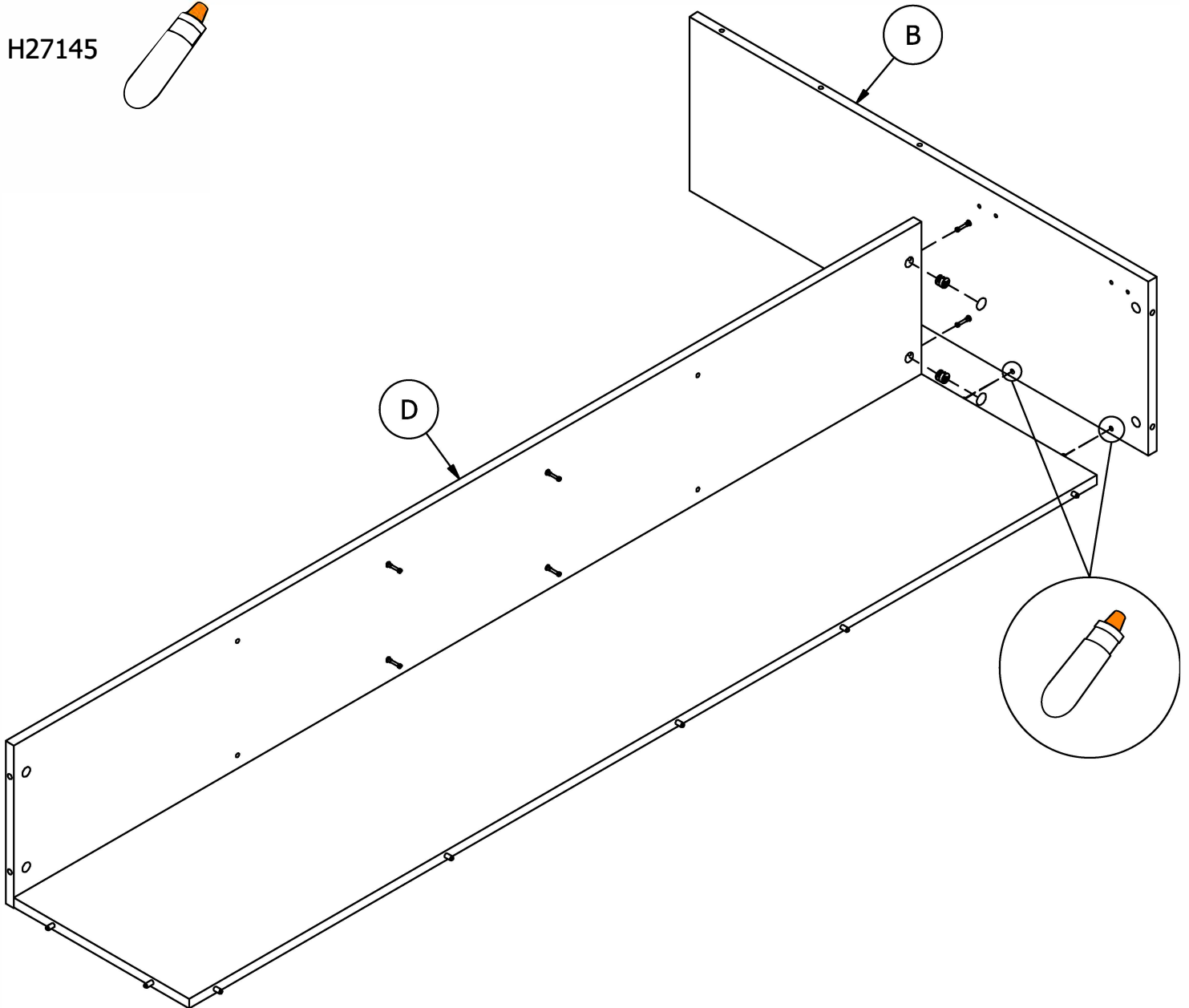

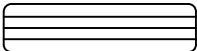
H27771  [8]
1/4 x 1

H27145

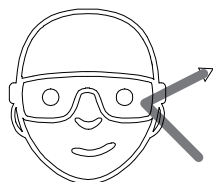
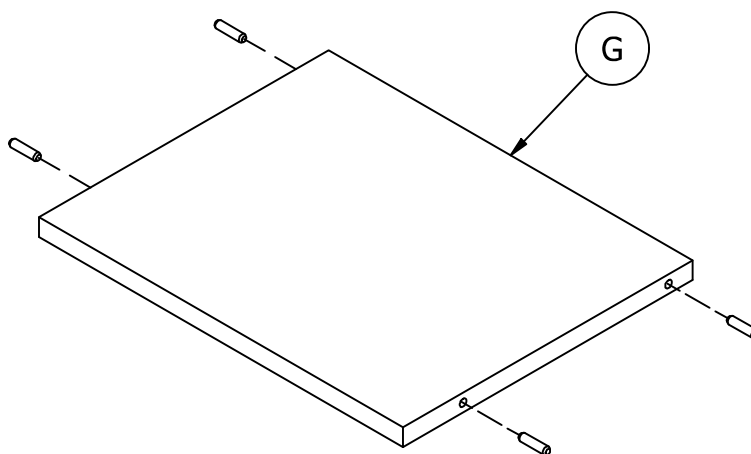
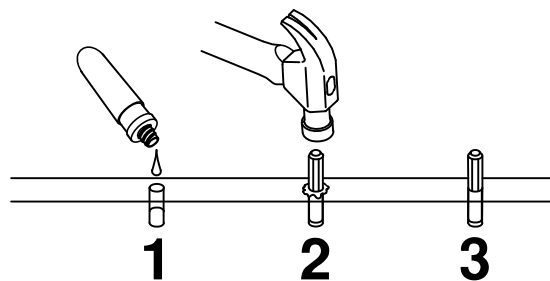

Safety glasses
Gafas de seguridad
Lunettes de protection

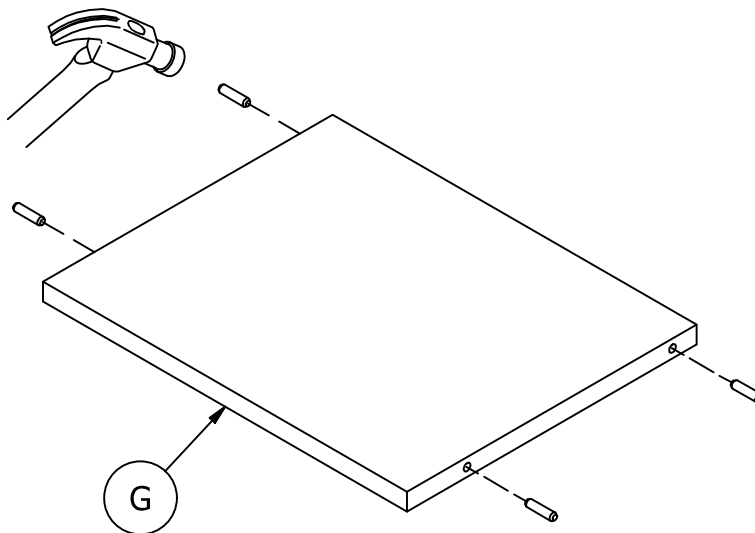

H27145

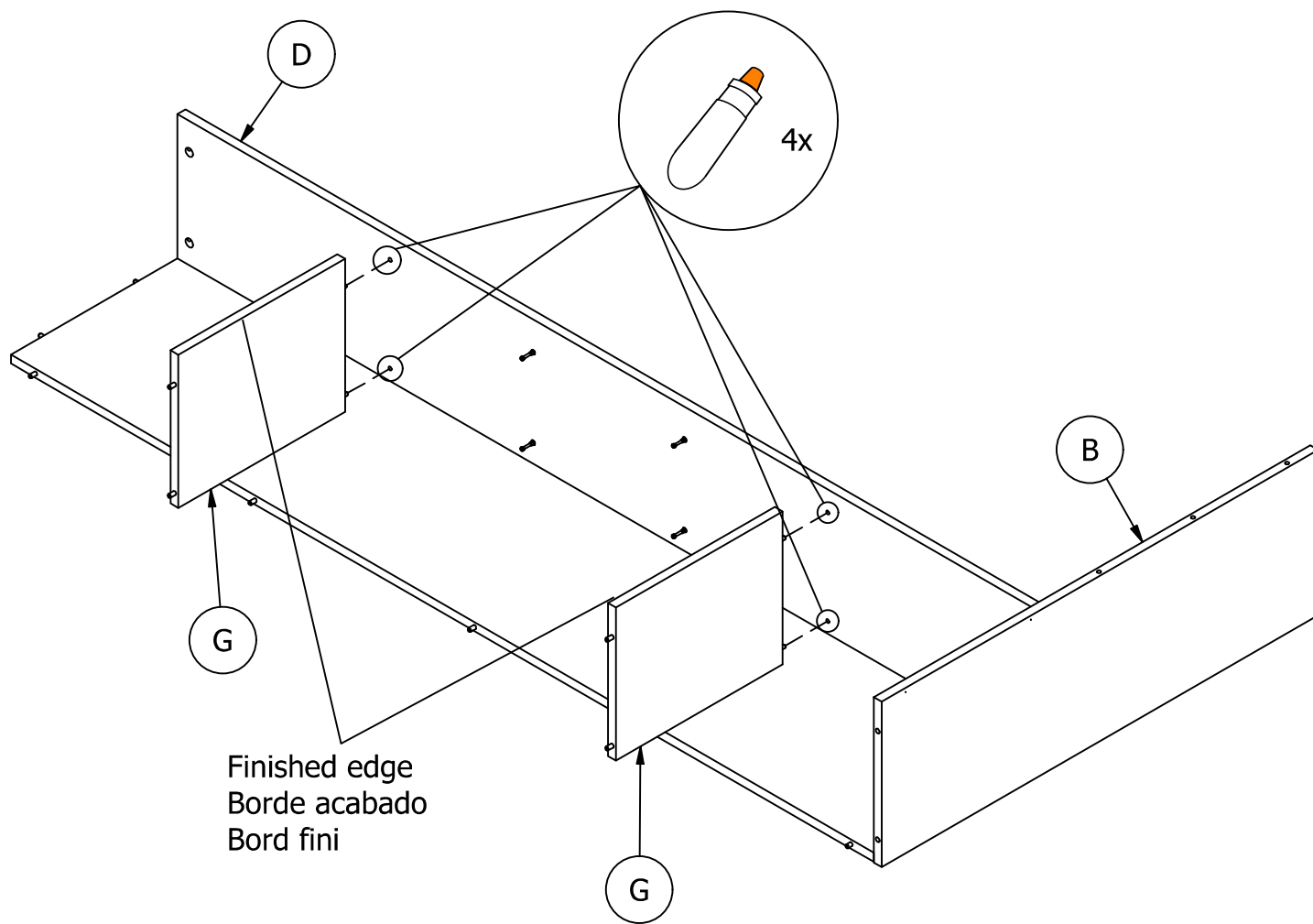
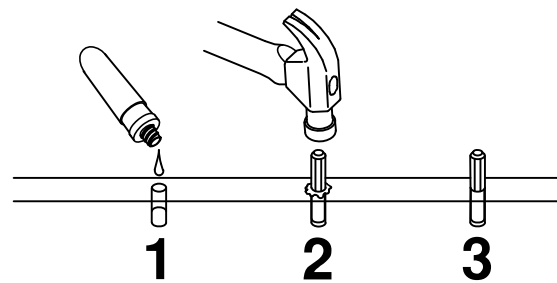

Finished edge
Borde acabado
Bord fini

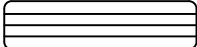
H27771  [8]
1/4 x 1

H27145

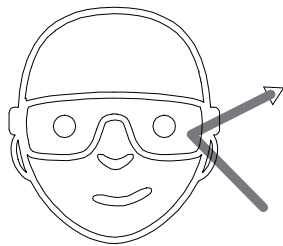
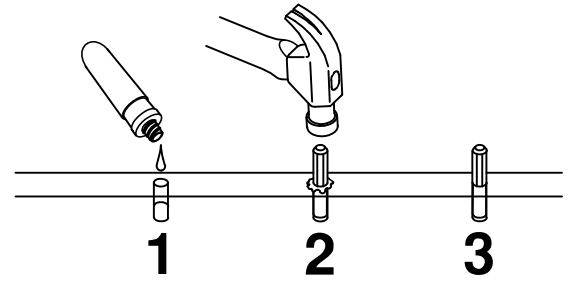
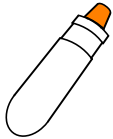

Safety glasses
Gafas de seguridad
Lunettes de protection

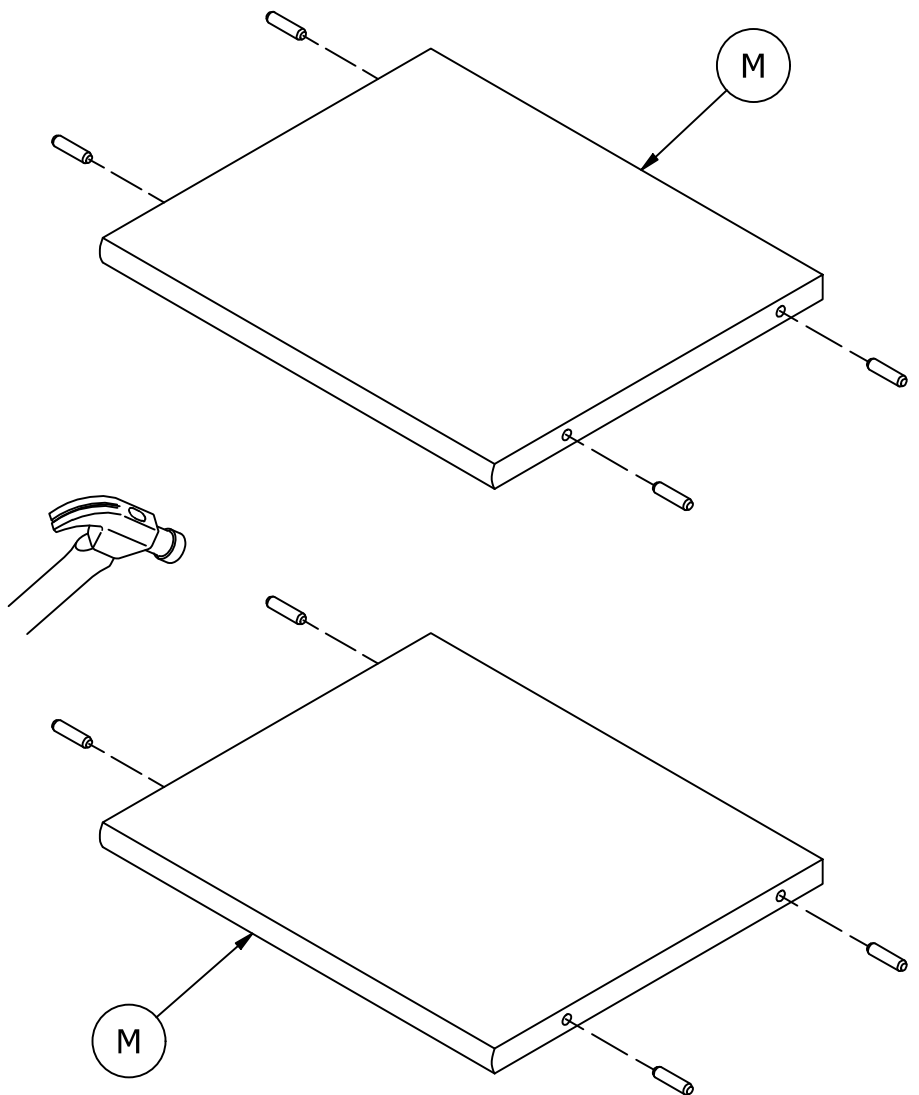

H27145

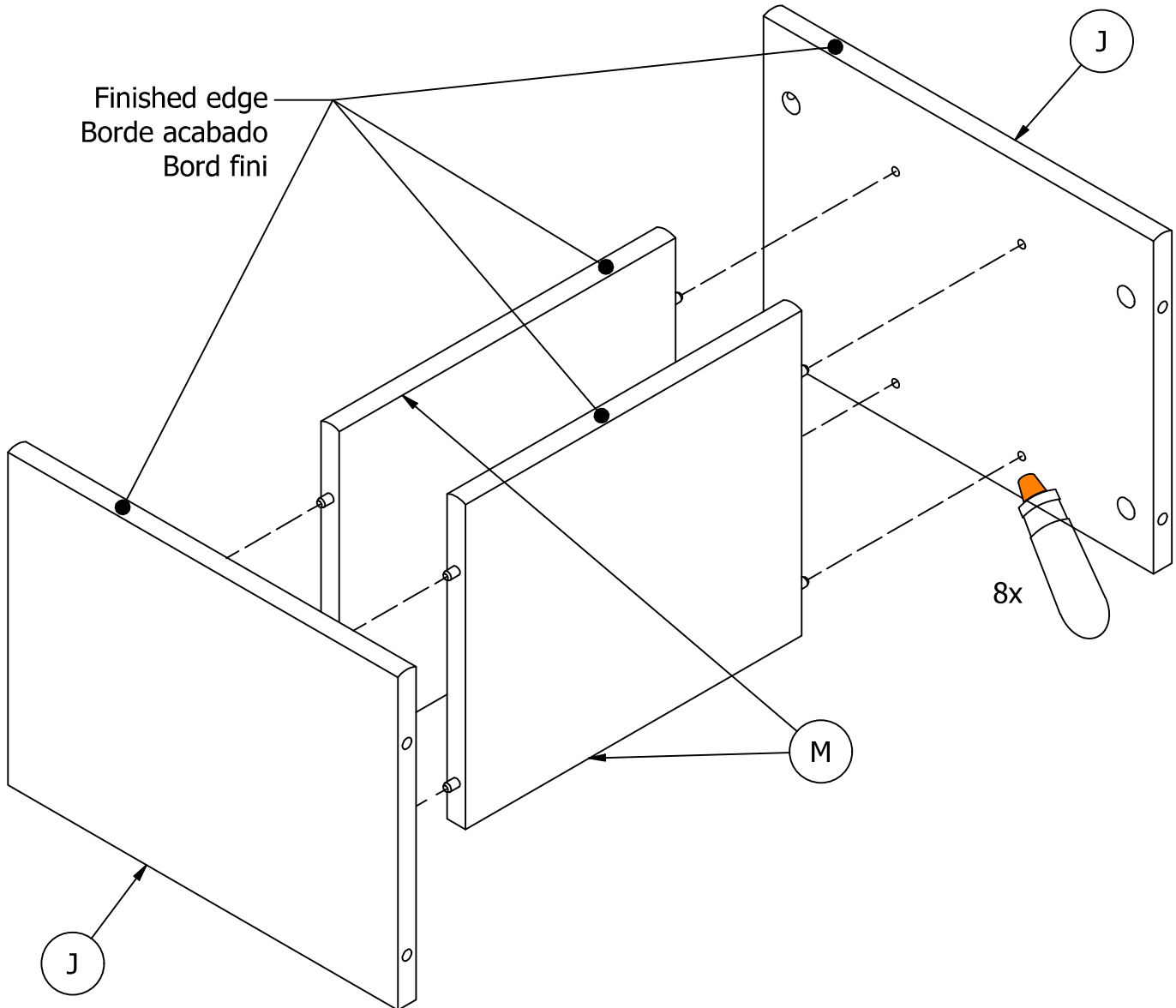
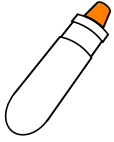

H181468US



[4]

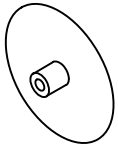

[4]

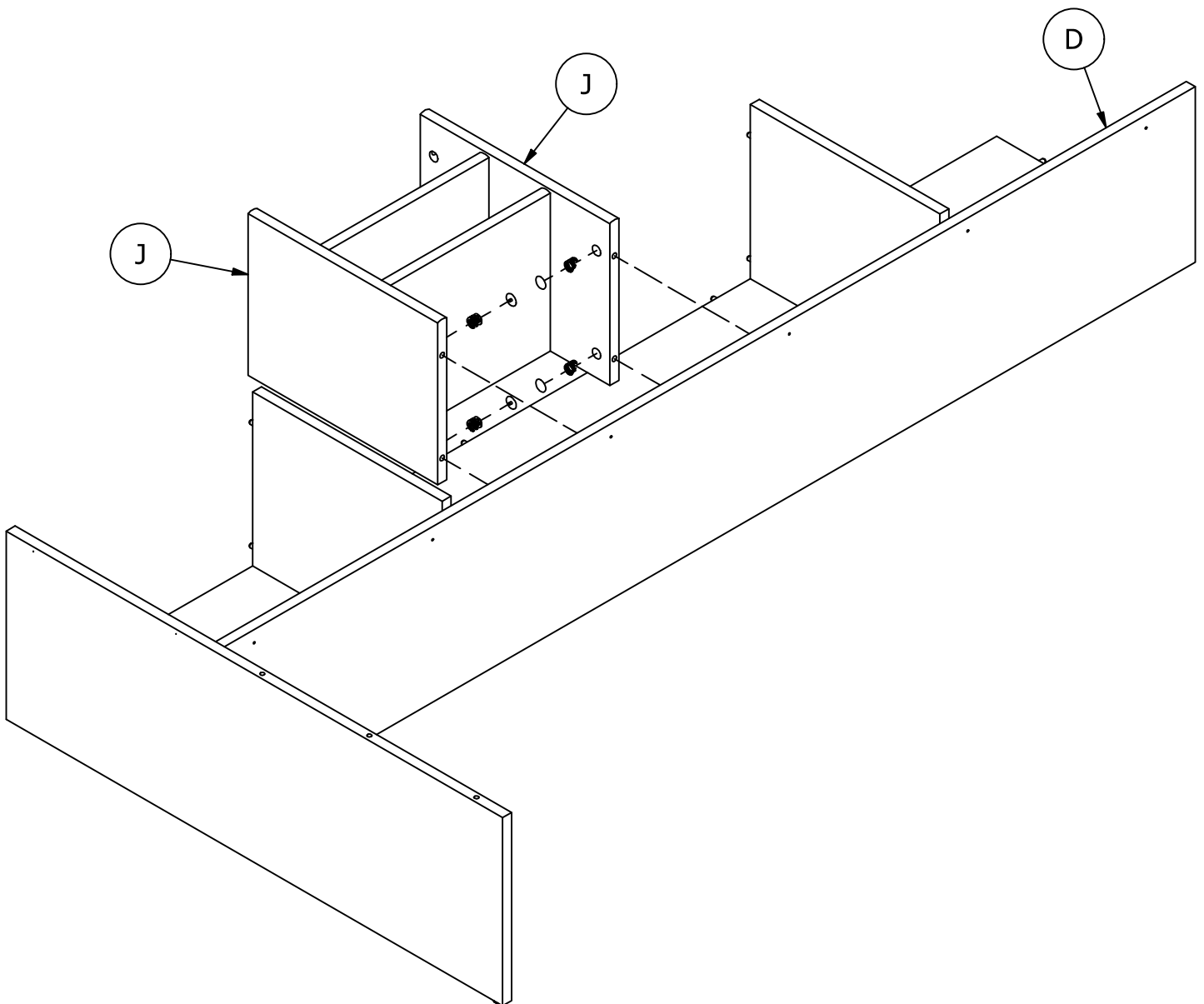
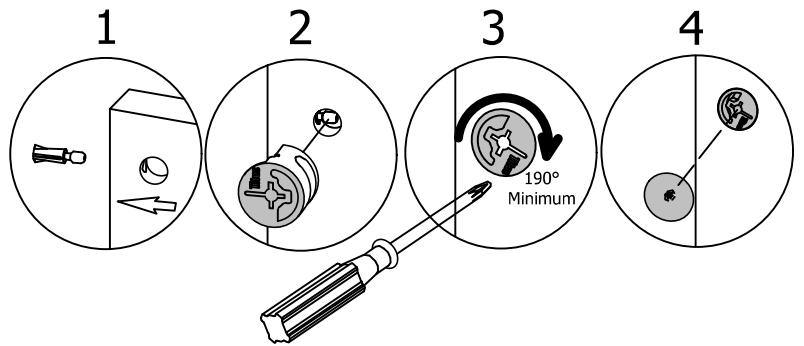

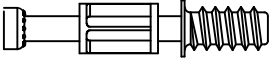
H72988  [2]

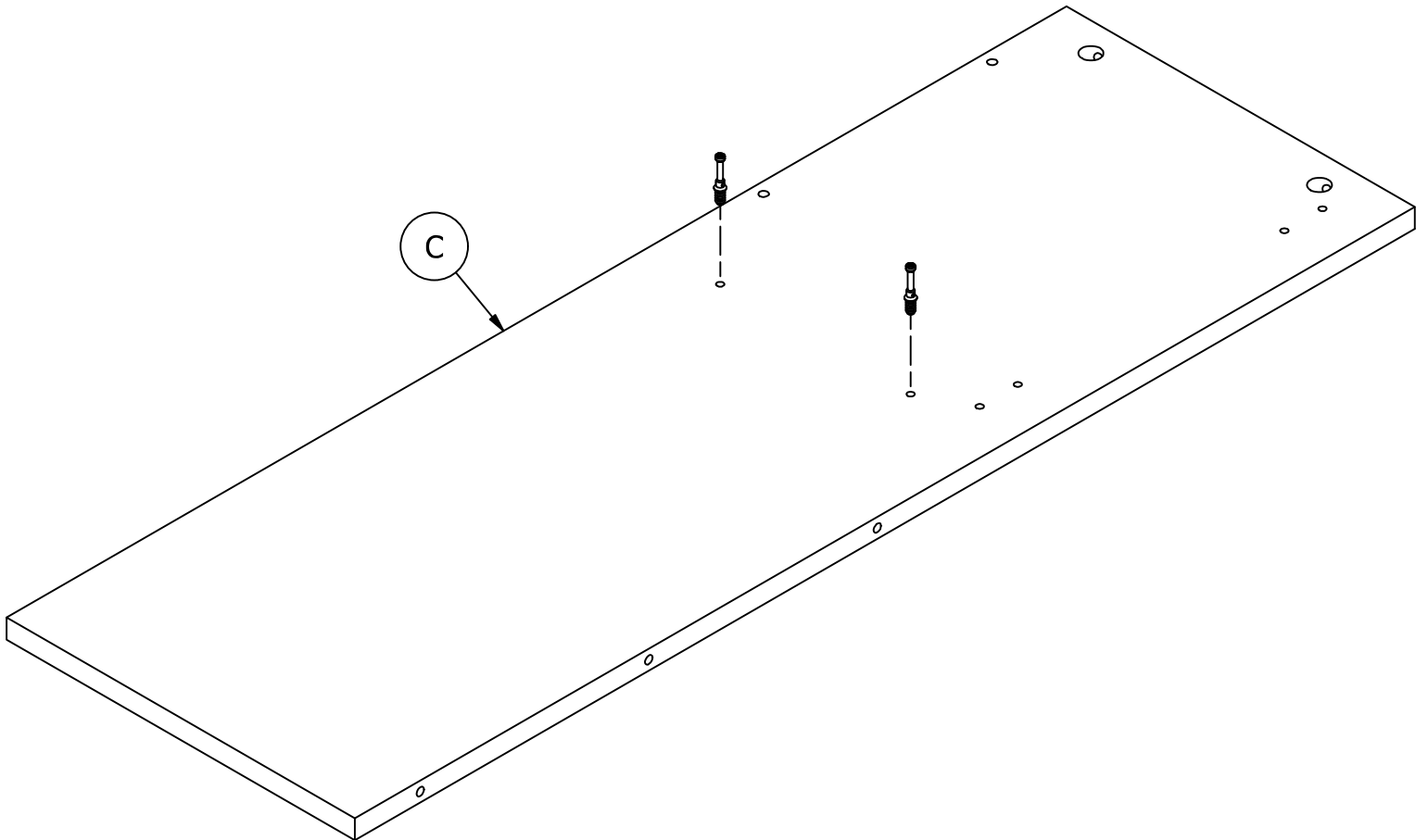
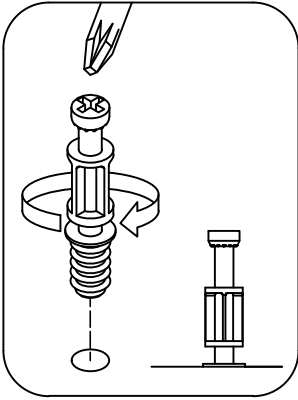

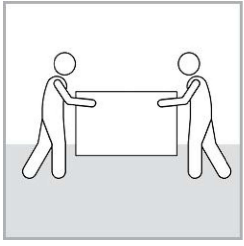

Team Lift
Esfuerzo de equipo
Effort d'équipe

H181468US



[2]

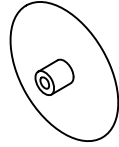

[2]

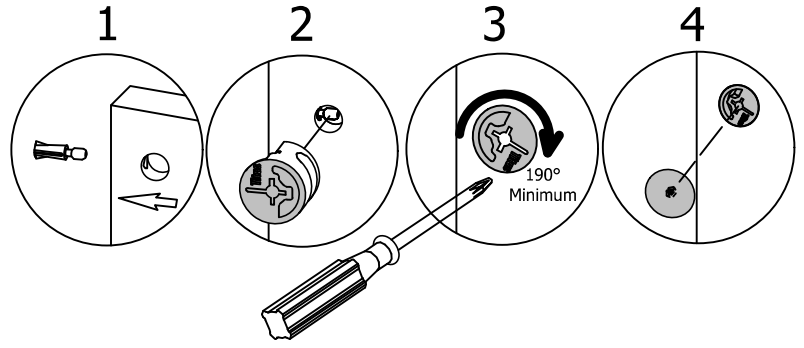

H27145

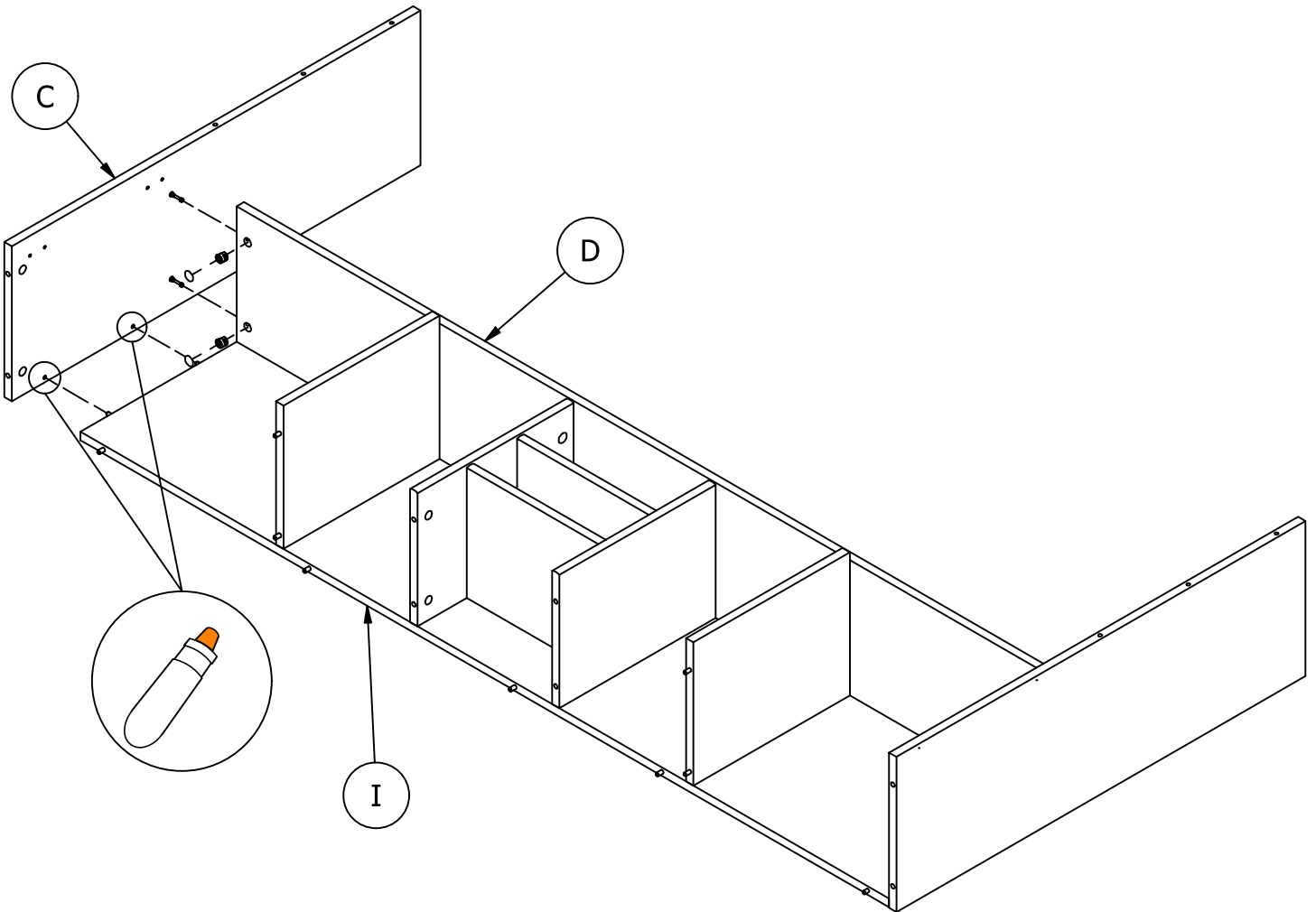

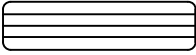
H27771  [4]
1/4 x 1

H27145

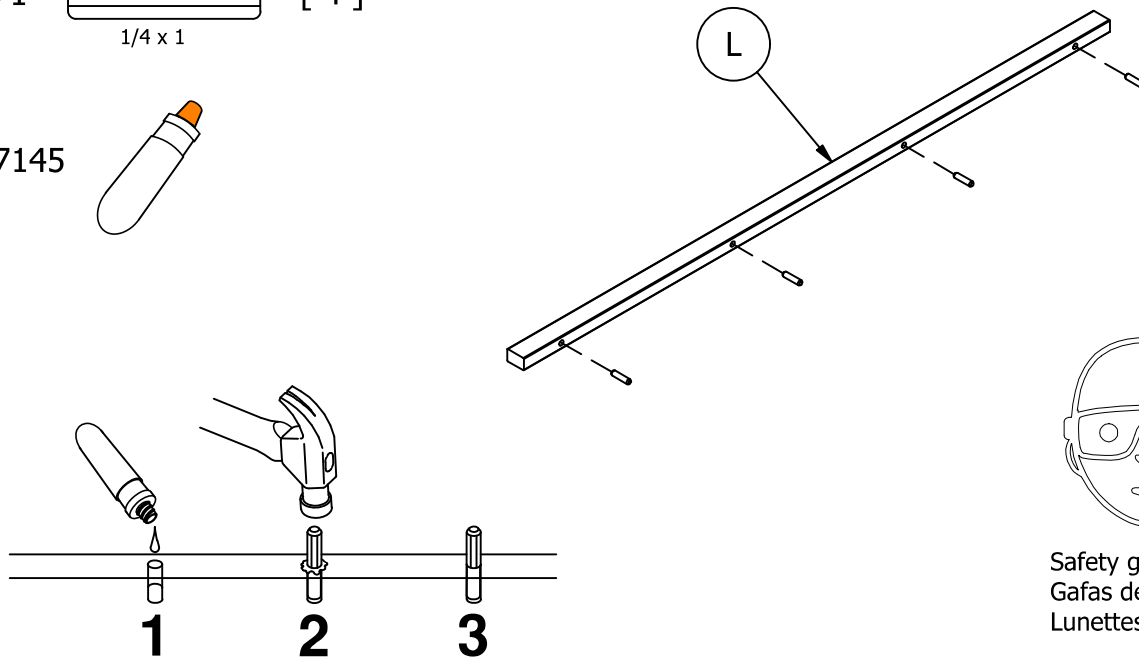

H72988  [8]

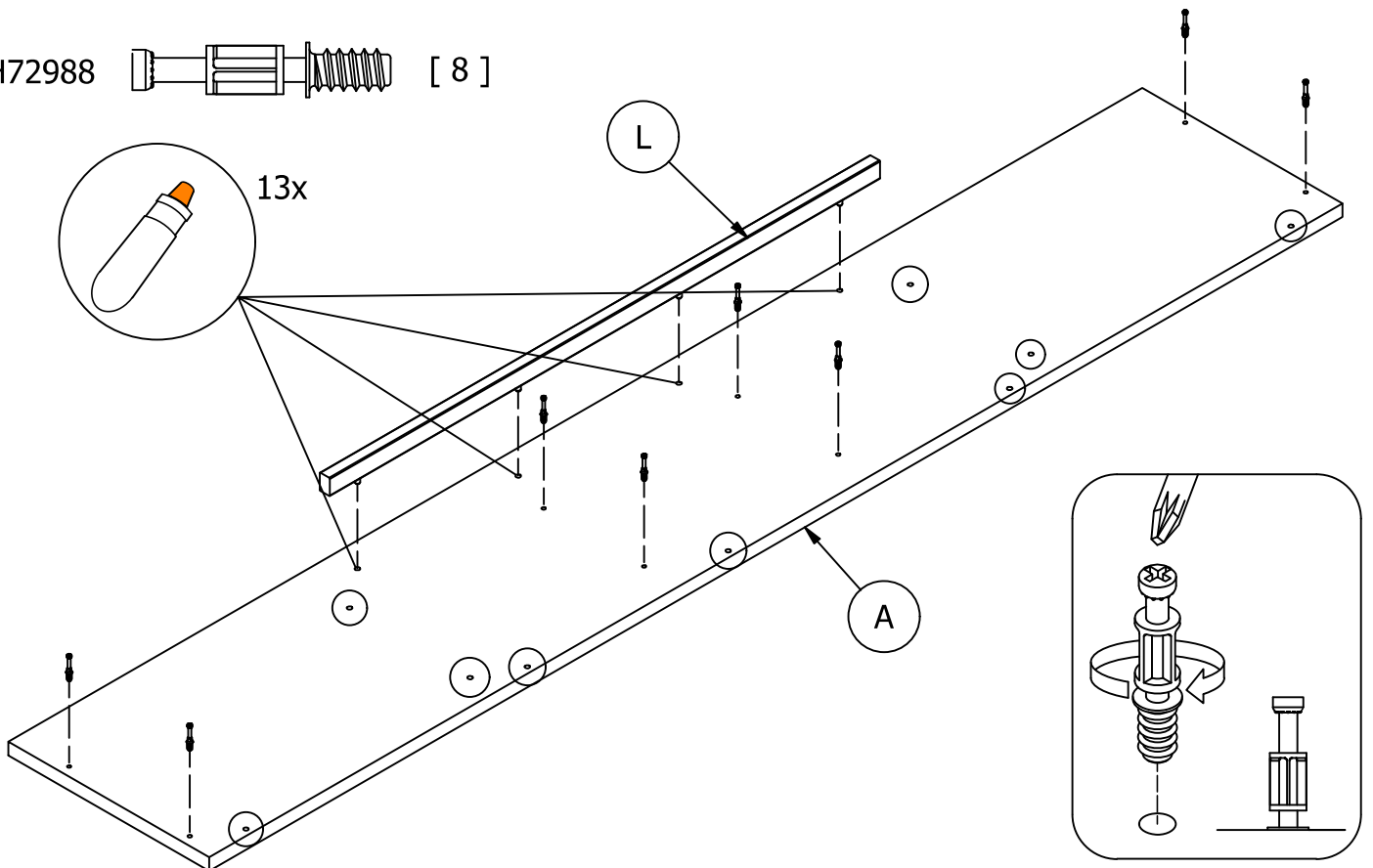

H181468US



[8]

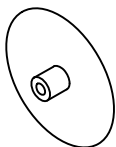

[8]

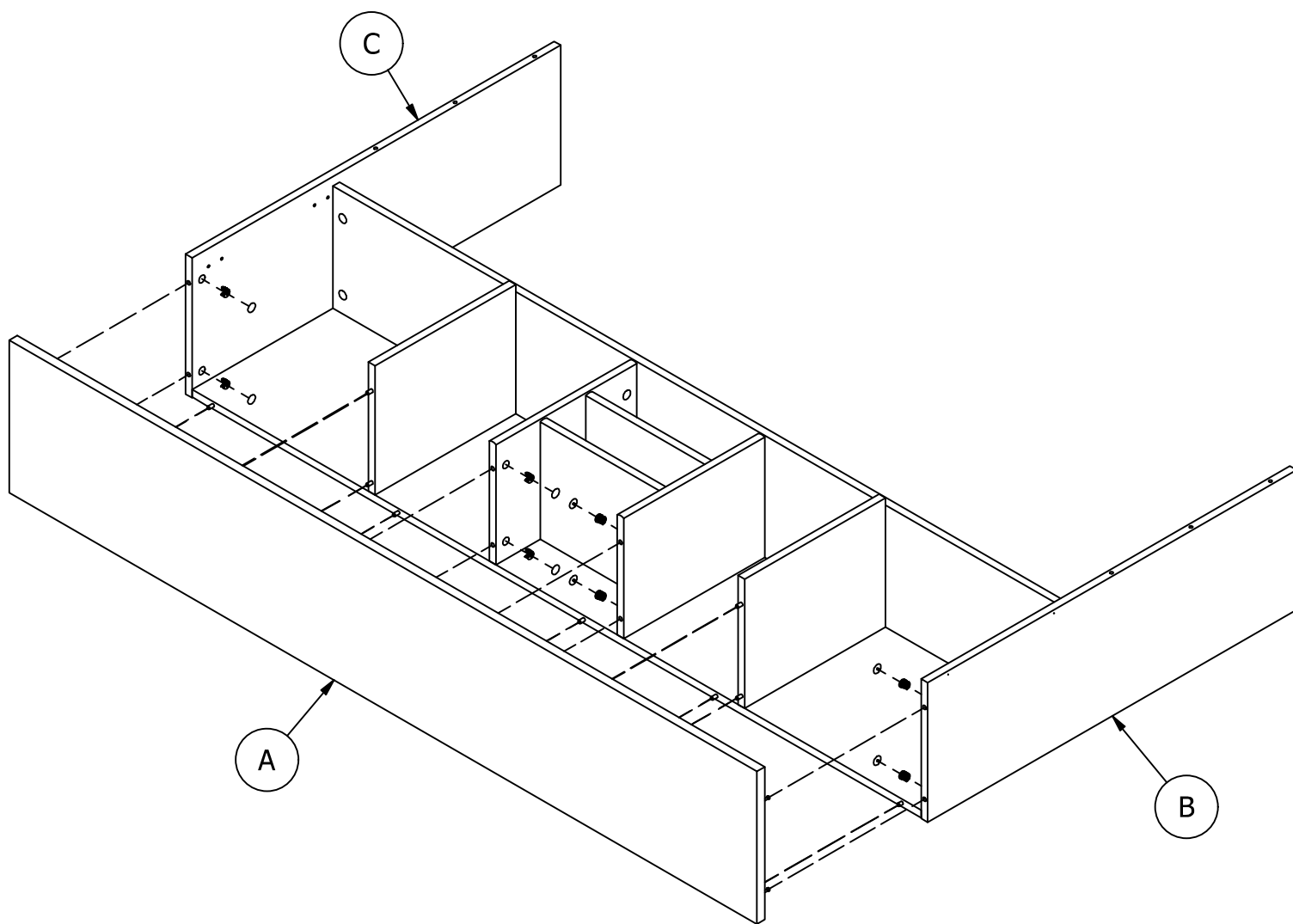
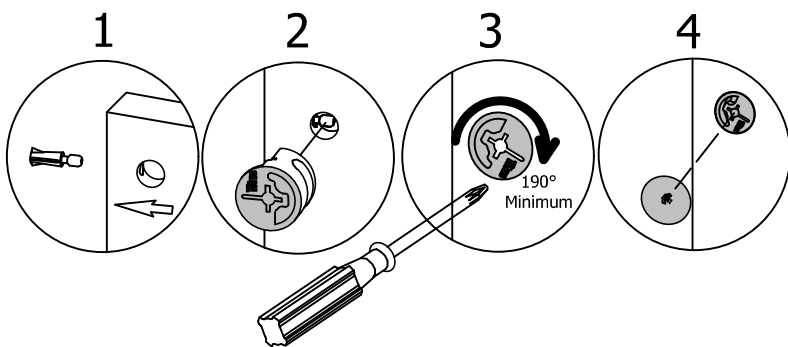

H43507 [6]
#8 x 1/2"

H67187 [6]

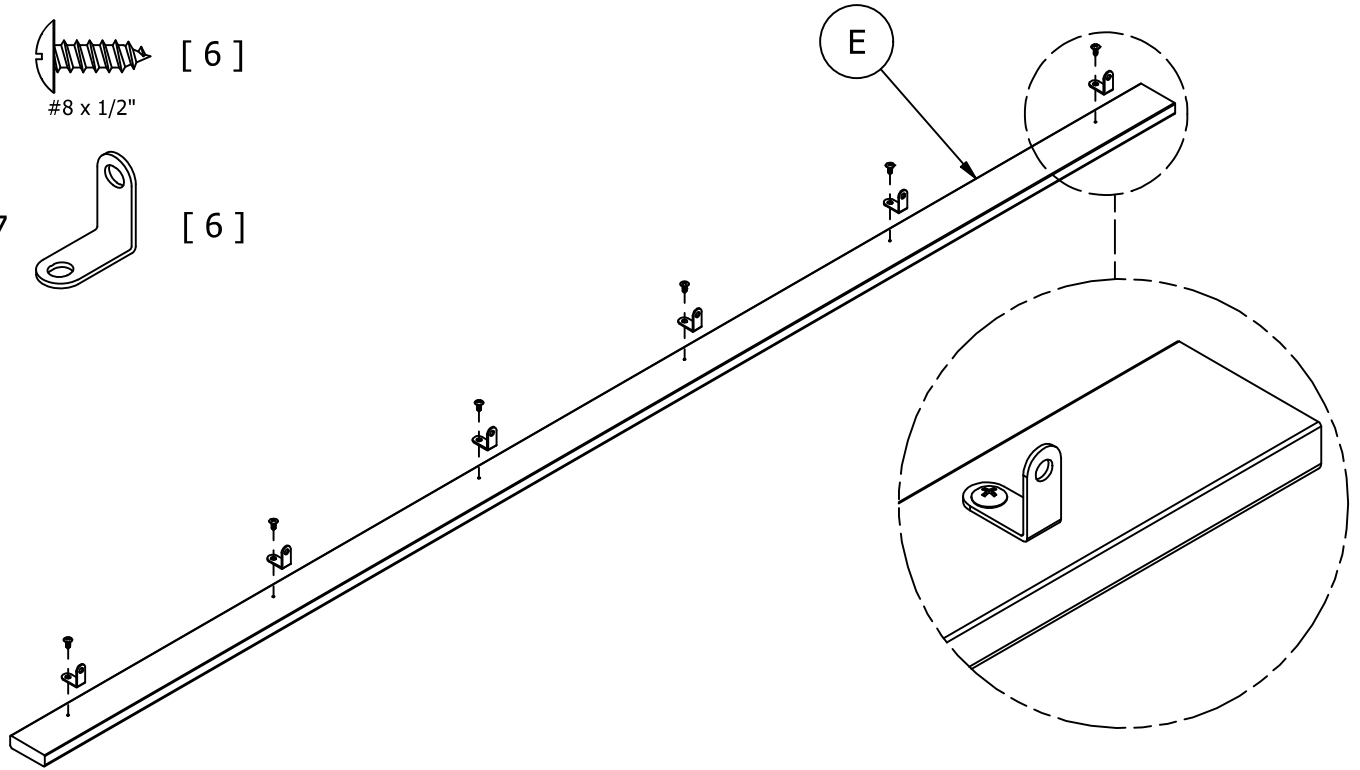

H43507 [6]
#8 x 1/2"

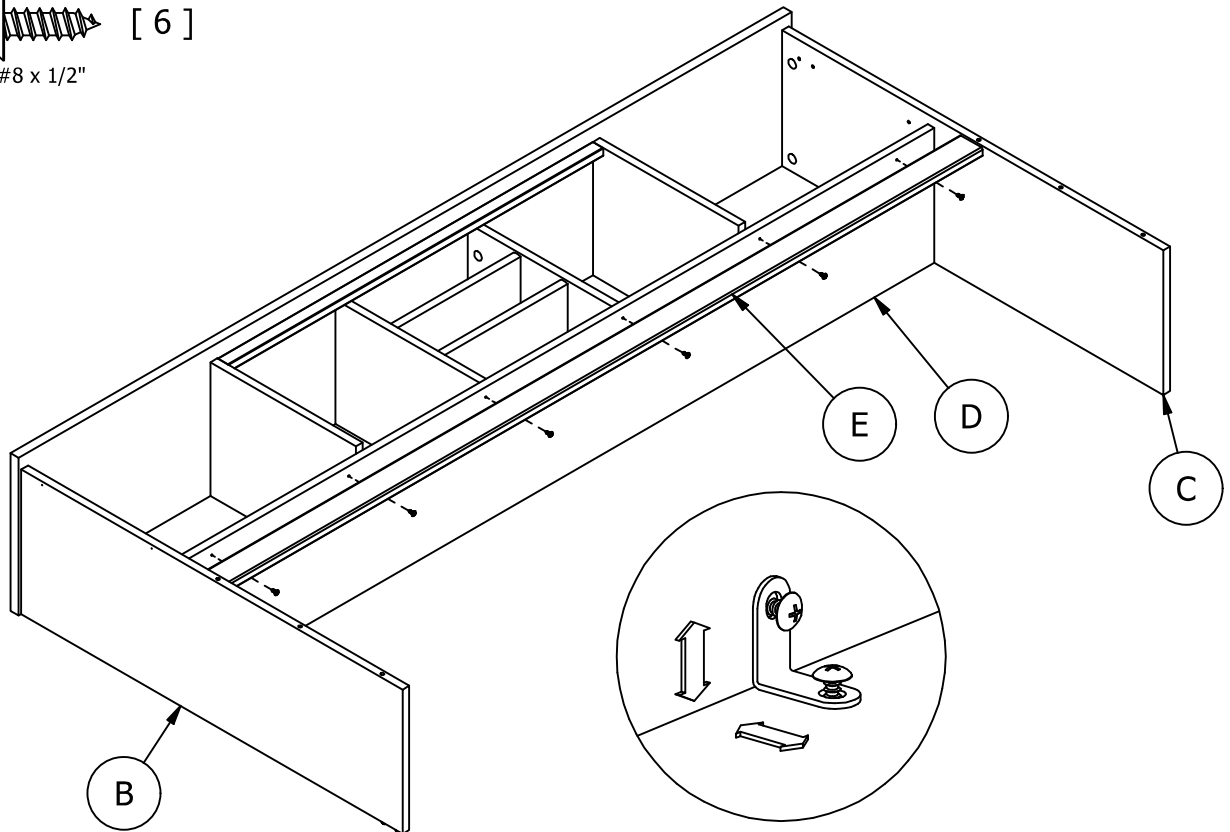

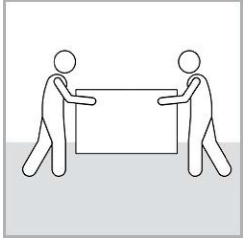

Team Lift
Esfuerzo de equipo
Effort d'équipe

H34174 [21]
Nail 19mm

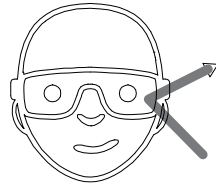
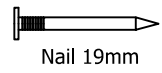

Safety glasses
Gafas de seguridad
Lunettes de protection

Flip unit over.
Voltee la unidad.
Retournez l'unité.

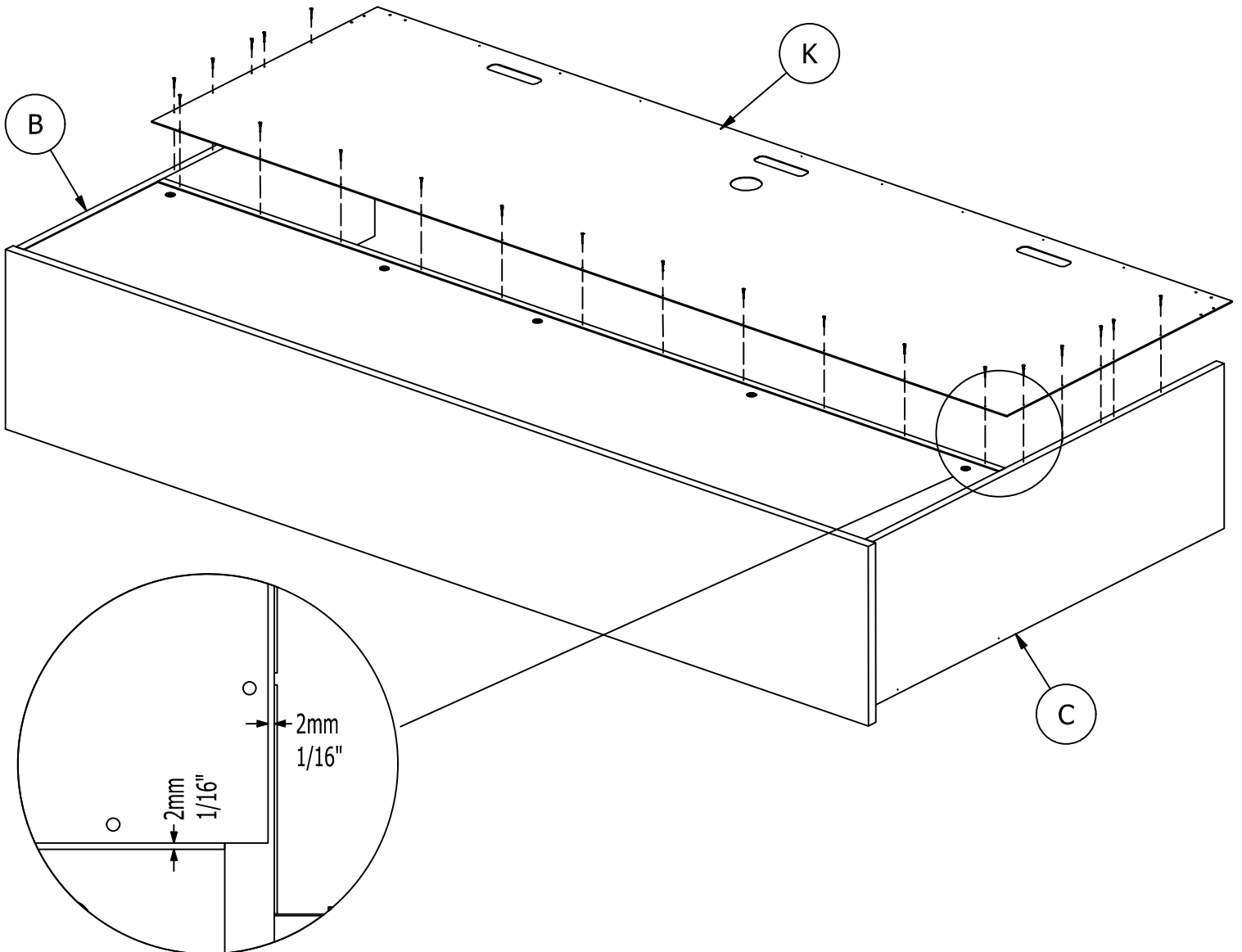
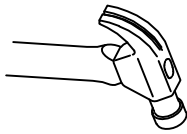

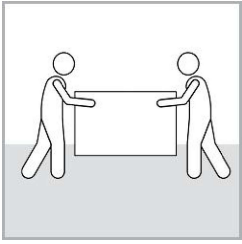

Team Lift
Esfuerzo de equipo
Effort d'équipe

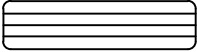
H27771  [6]
1/4 x 1

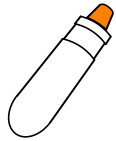
H27145 

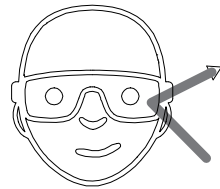
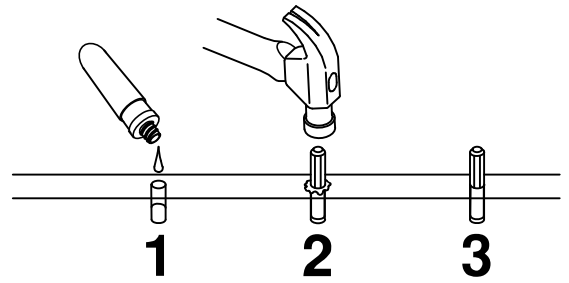

Safety glasses
Gafas de seguridad
Lunettes de protection

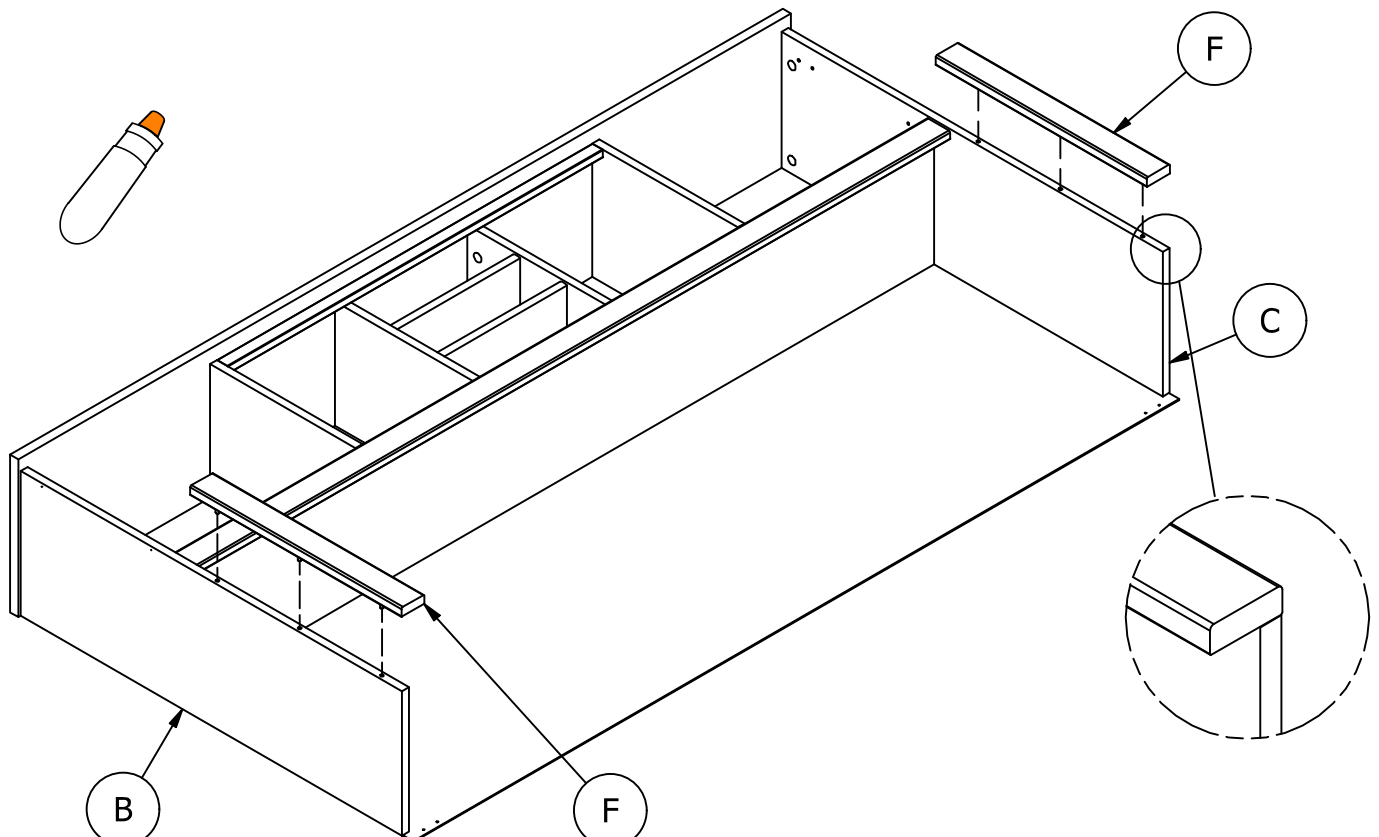
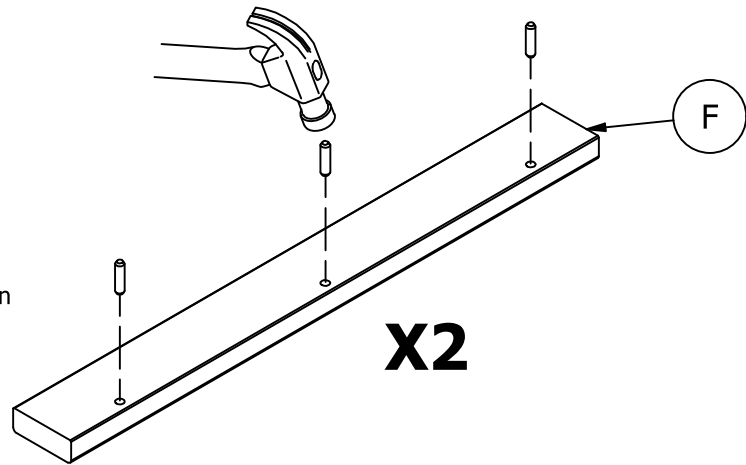

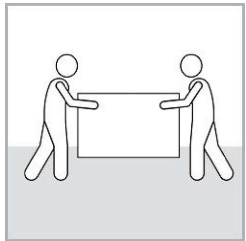

Team Lift
Esfuerzo de equipo
Effort d'équipe

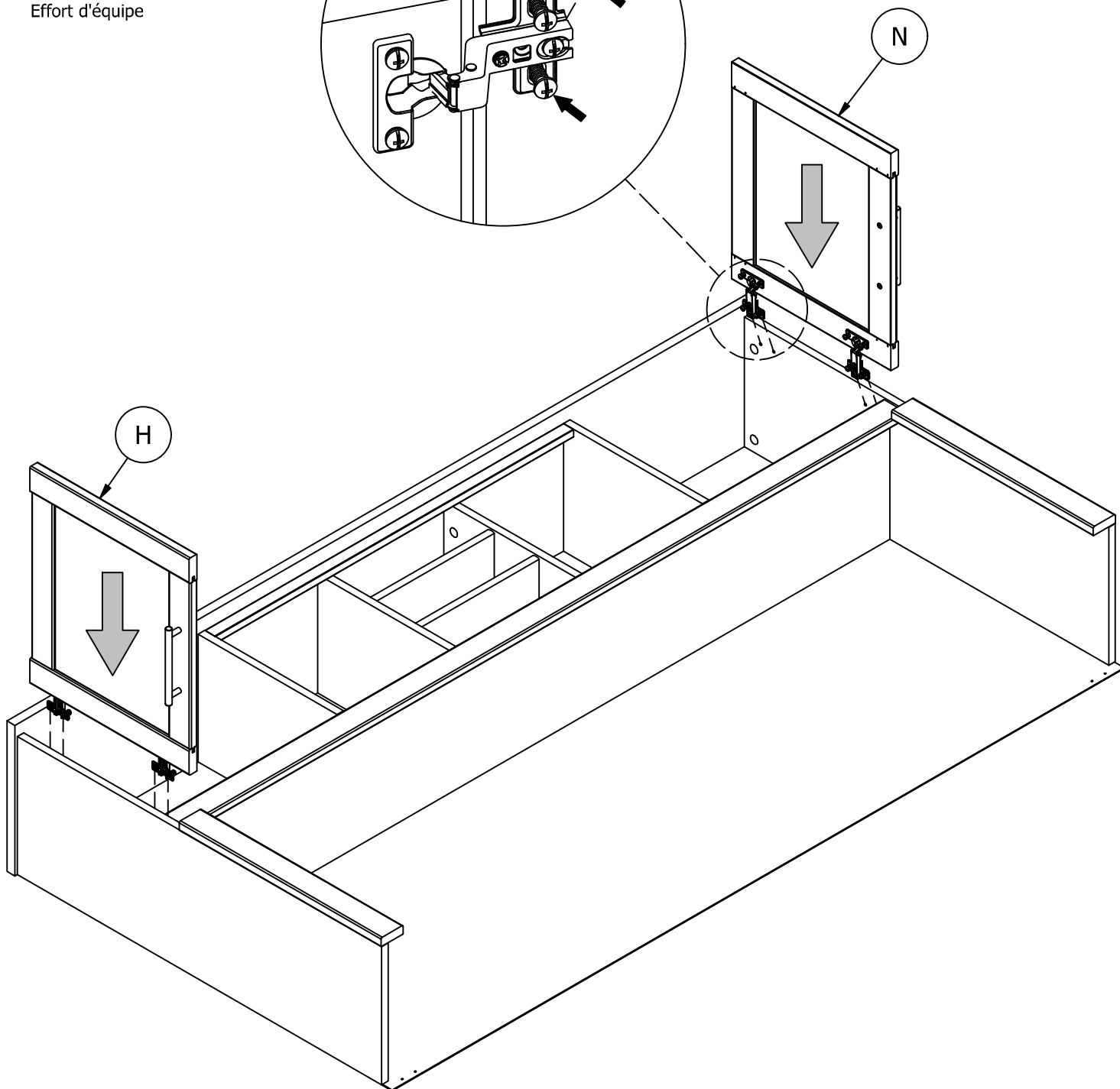
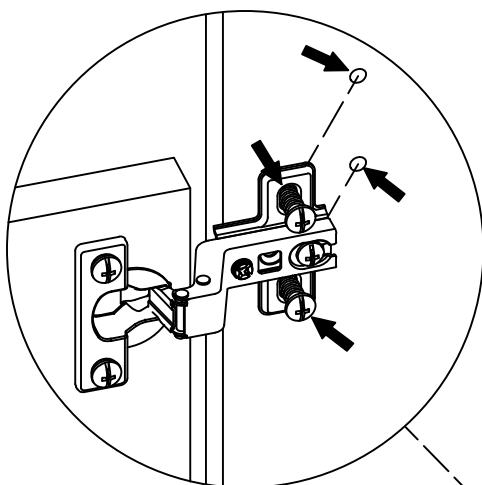

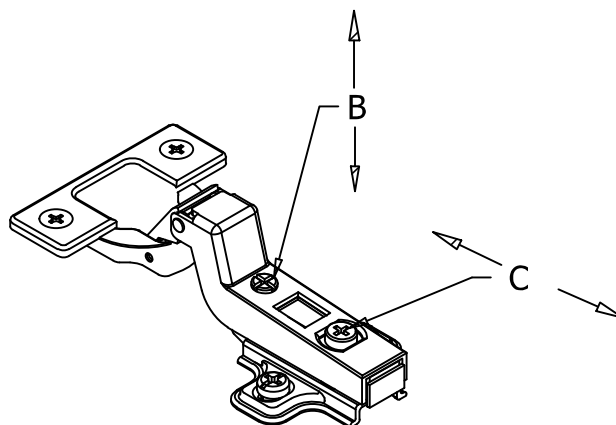
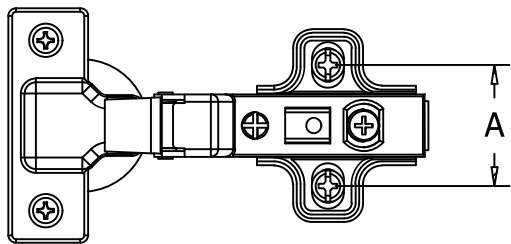

Door Adjustment
Ajustement des portes
Ajuste de la puerta

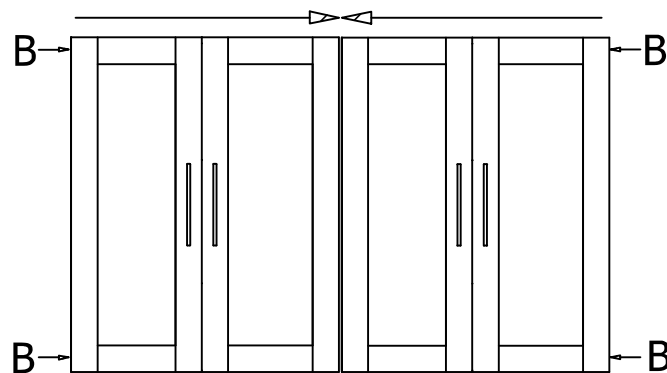
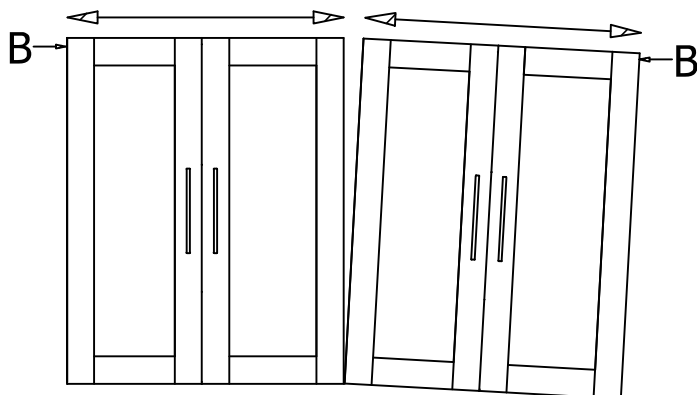
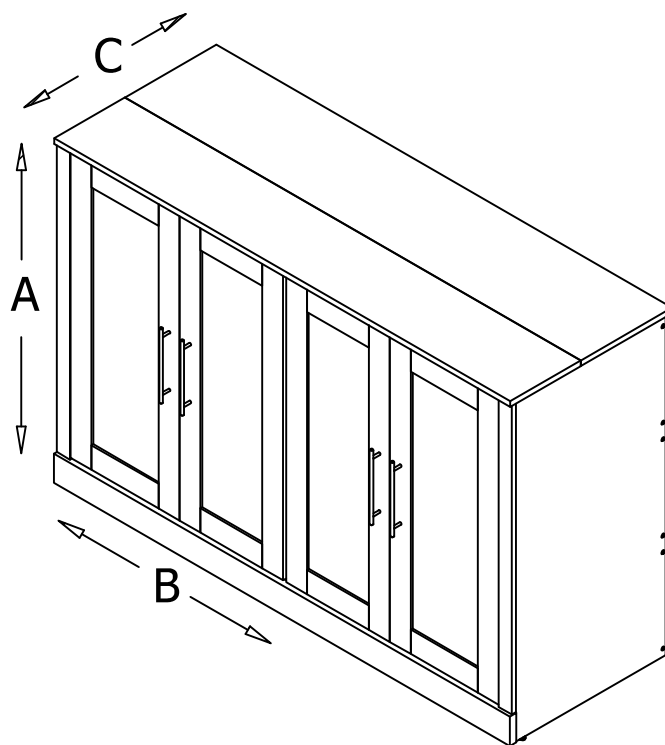

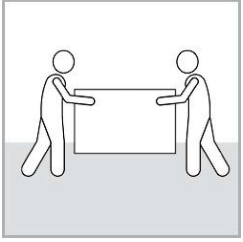

Team Lift
Esfuerzo de equipo
Effort d'équipe

H23682

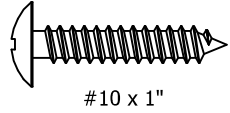

[8]

#10 x 1"

H34174

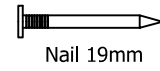

[9]

Nail 19mm

H85966

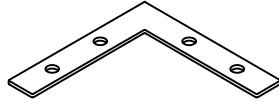

[2]

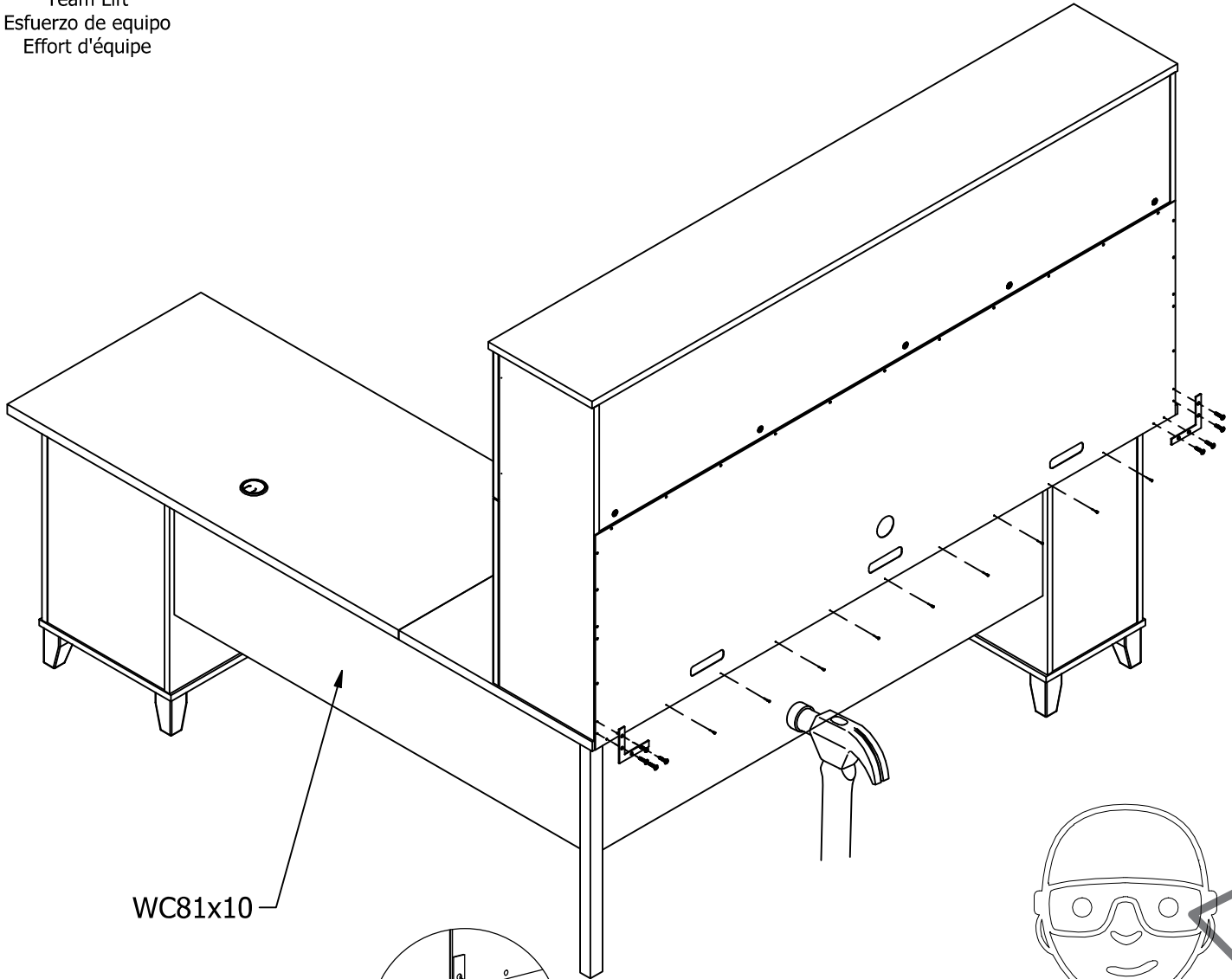

WC81x10

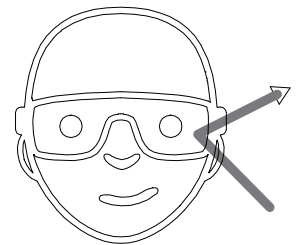
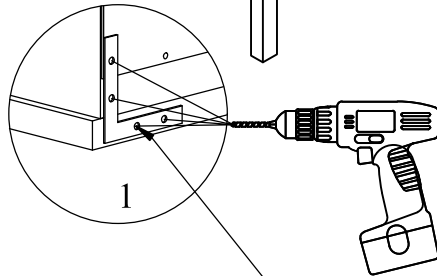

Safety glasses
Gafas de seguridad
Lunettes de protection

Drill (8) 1/8" holes 3/4" deep.
Perfore (8) agujeros de 3mm a 19mm de profundo.
Percer (8) trous de 3mm de diamètre et 19mm de profondeur.

Secure unit to the wall with a tip-over restraint.

Unidad de seguro a la pared con un sistema de retención de un vuelco.

Fixer l'unité au mur avec un dispositif de retenue renversement.

1. Place unit in desired location.
2. Locate wall stud nearest unit center. **FIG A**
3. On wall, mark center of stud location 1" below top of unit. **FIG A**
4. If a wall stud cannot be located mark hollow wall at unit center. **FIG A**
5. On back of unit, mark corresponding location 3/8" below top of unit. **FIG B**

1. Coloque la unidad en el lugar deseado.
2. Localice pie derecho de pared centro de unidad más próxima.
3. En la pared del, marque el centro de la ubicación del montante 1 "abajo la parte superior de la unidad.
4. Si un poste de la pared no se puede localizar marcar pared hueca en el centro de la unidad.
5. En el dorso de la unidad, marque la ubicación 3/8 correspondiente abajo la parte superior de la unidad.

1. Placez l'unité à l'endroit désiré.
2. Localiser centre d'unité la plus proche de la paroi Stud.
3. Sur le mur, centre de emplacement du montant 1 "ci-dessous dessus de l'appareil de la marque.
4. Si un montant de mur ne peut pas être situé marquer mur creux au centre de l'unité.
5. Le dos de l'appareil, marquer l'emplacement 3/8 correspondant ci-dessous dessus de l'appareil.

FIG A

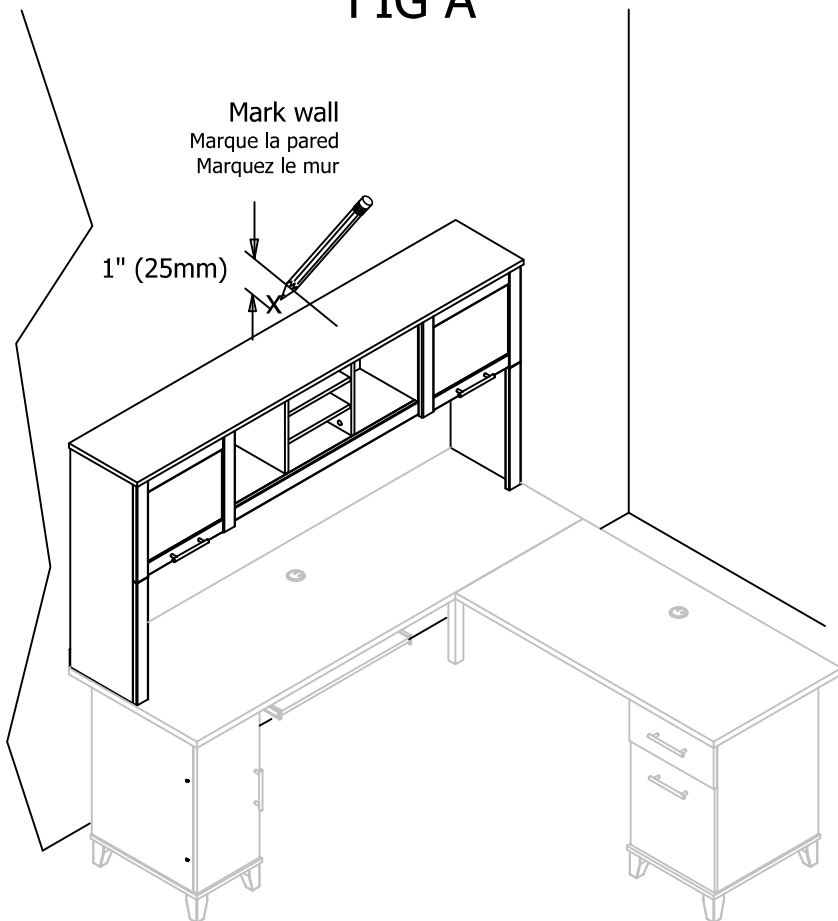
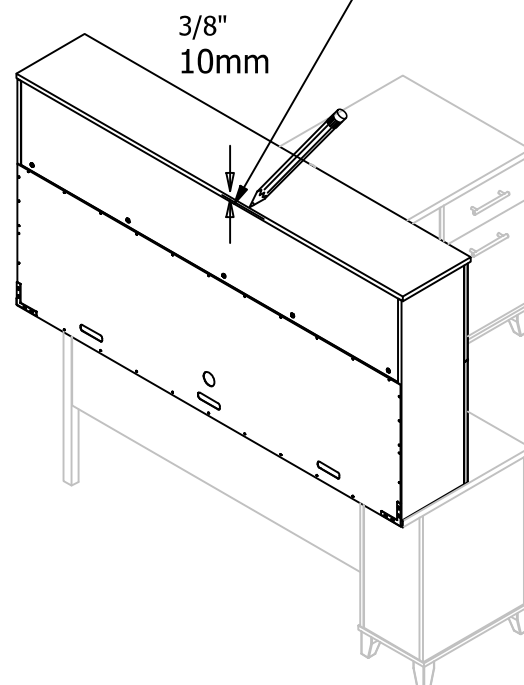

FIG B

Mark back within 6" (150mm) of center.
 Marcar de vuelta dentro de 6" (150mm) de centro
 Mark dans les 6" (150mm) de centre.



WALL STUD ATTACHMENT

FIJACIÓN A LOS MONTANTES DE LA PARED
 FIXATION AUX MONTANTS DU MUR

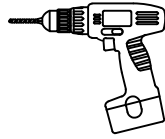

Drill 1/8" hole 2" deep at mark on wall.
 Taladro 1/8 "agujero 2" de profundidad en la marca en la pared.
 Percer 1/8 "trou de 2" de profondeur à la marque sur le mur.

H181434

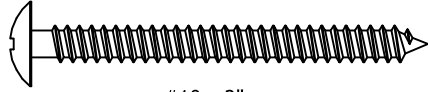

[1]

#10 x 2"

H181412



[1]

Connecting Plate

Wood stud
 Montante de madera
 Stud bois

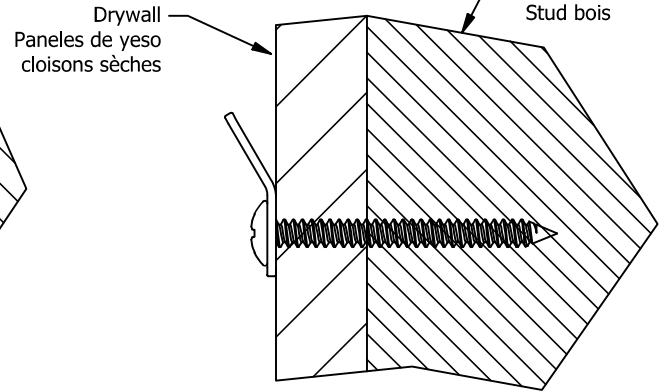
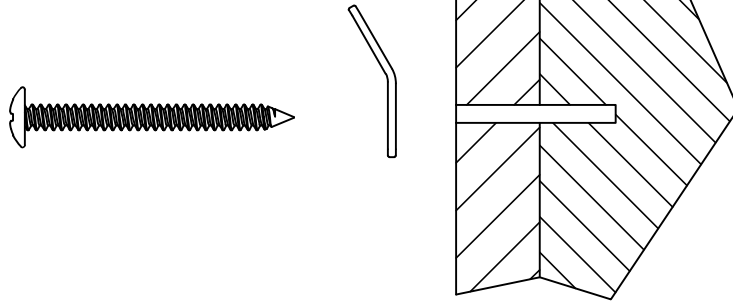

HOLLOW WALL ATTACHMENT

FIJACIÓN A PARED HUECA
 FIXATION SUR MUR CREUX

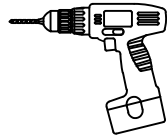

Drill 1/2" hole 1" deep at mark on wall.
 Taladro 1/2 "agujero 1" de profundidad en la marca en la pared.
 Percer 1/2 "trou de 1" de profondeur à la marque sur le mur.

H181419

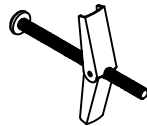

[1]

Toggle Bolt

H181412



[1]

Connecting Plate

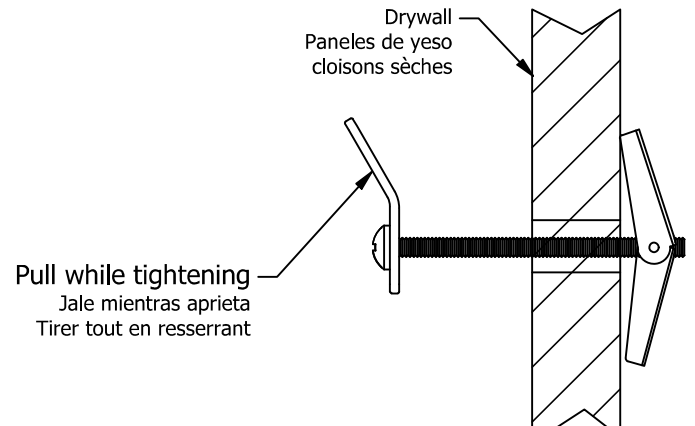
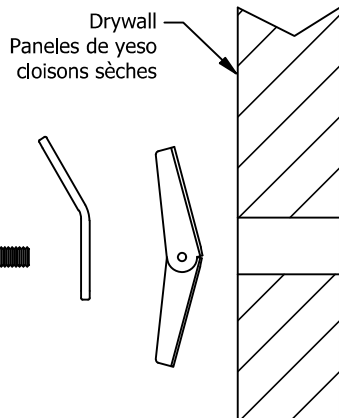

H107572

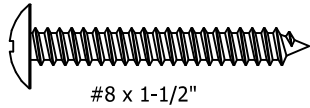

[1]

H181412

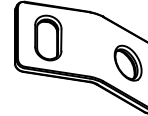

[1]

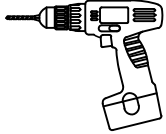

Drill 1/8" hole 1" deep at mark on unit.

Taladro 1/8 "agujero de 1" de profundidad en la marca de la unidad.

Perçer 1/8 "trou 1" de profondeur à la marque sur l'unité.

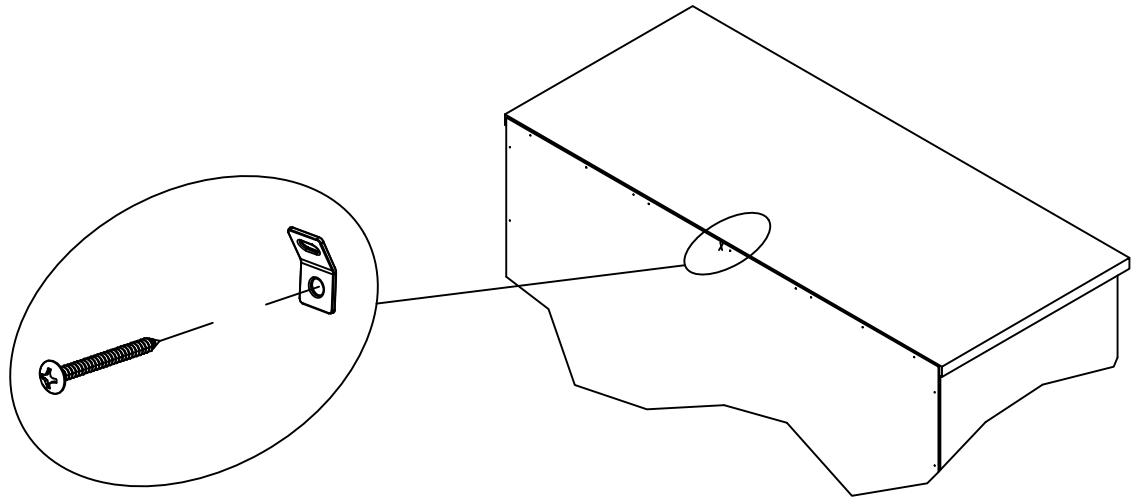

H181411

[1]

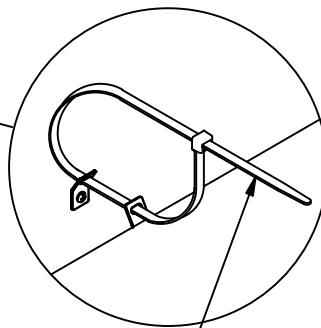
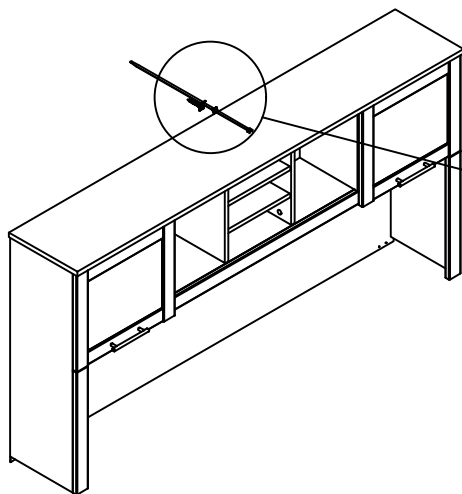
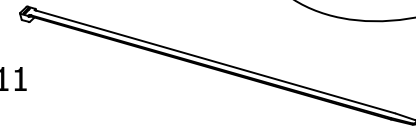

Pull to verify lock

Tire para verificar cerradura

Tirez pour vérifier serrure

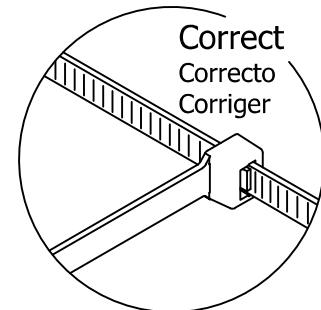

Use replacement cable tie with minimum breaking strength of 120lbs.

Utilice reemplazo empate Cable con resistencia a la rotura mínima de 120 libras.

Utilisez remplacement Attache de câble avec une force de rupture minimale de 120 lbs.

Gently clean surfaces with a damp sponge eraser.
Limpie suavemente las superficies con una esponja húmeda.
Nettoyer délicatement les surfaces à l'aide d'une éponge humide.

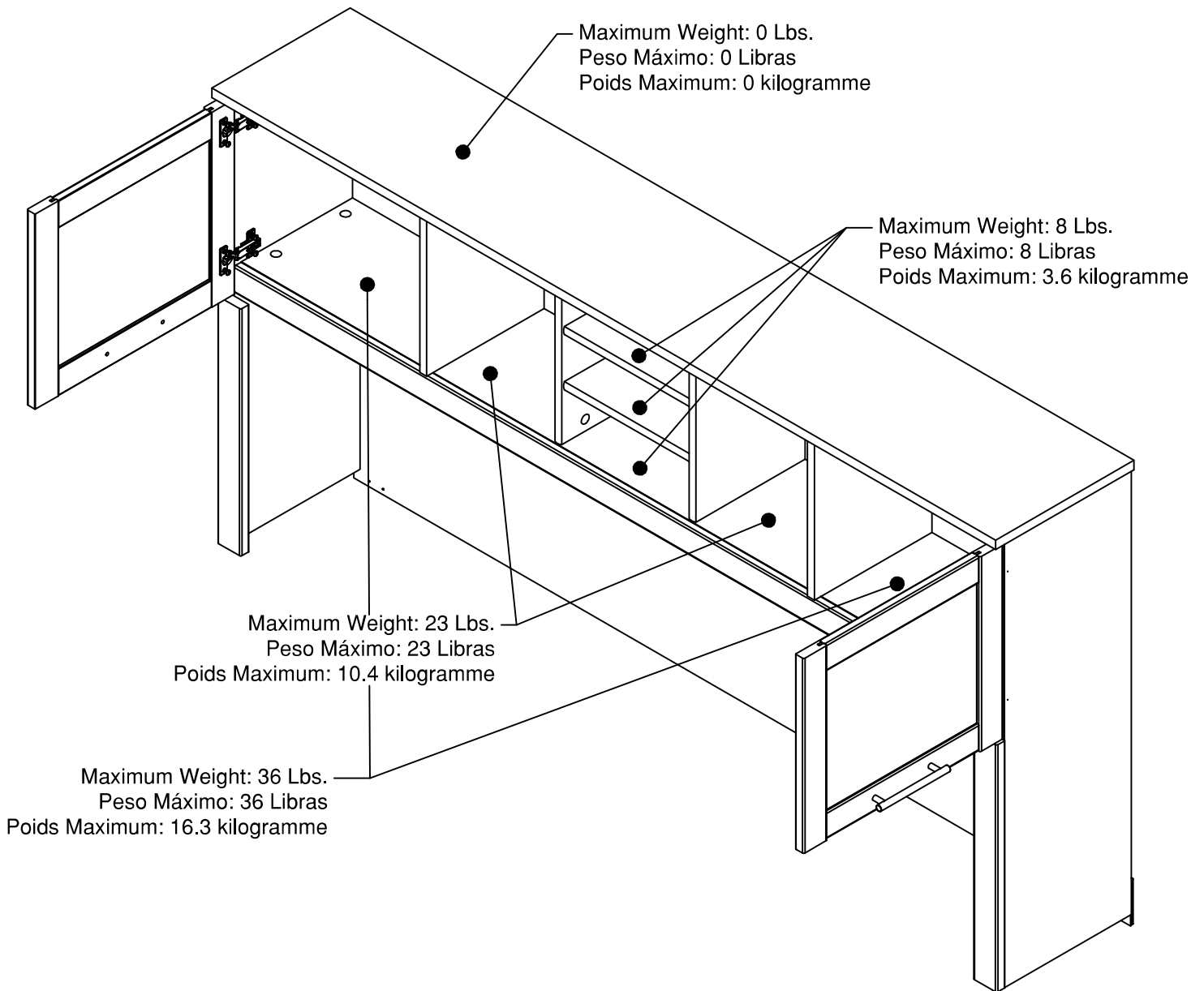

Congratulations! You are all done.
¡Felicidades! Ha finalizado el proceso.
Félicitations! Vous avez terminé.

Parts - Pièces - Piezas

WC81011		
LABEL	QTY	NUMBER
A	1	W196064
B	1	W196065
C	1	W196066
D	1	W193899
E	1	W196068
F	2	W196061
G	2	W196069
H	1	S220709
I	1	W193902
J	2	W193903
K	1	W193904
L	1	W196073
M	2	W193906
N	1	S220710

WC81111		
LABEL	QTY	NUMBER
A	1	W200476
B	1	W200477
C	1	W200478
D	1	W200479
E	1	W200480
F	2	W200473
G	2	W200481
H	1	S220711
I	1	W200482
J	2	W200483
K	1	W200484
L	1	W200485
M	2	W200486
N	1	S220712

WC81211		
LABEL	QTY	NUMBER
A	1	W195857
B	1	W195858
C	1	W195859
D	1	W195860
E	1	W195861
F	2	W195854
G	2	W195862
H	1	S220713
I	1	W195863
J	2	W195864
K	1	W195865
L	1	W195866
M	2	W195867
N	1	S220714

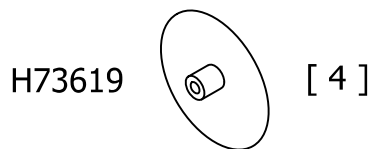
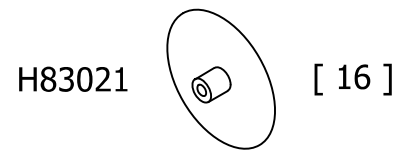
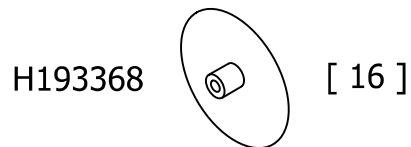
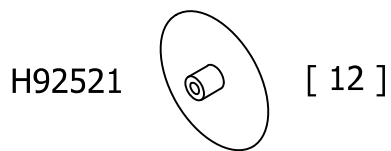
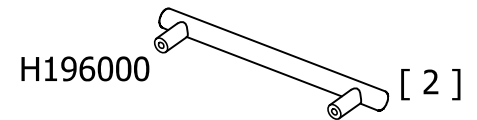
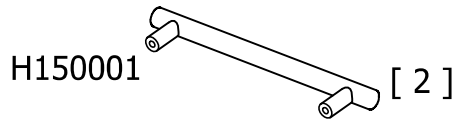
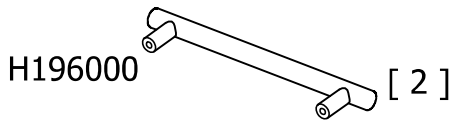

Parts - Pièces - Piezas

WC81311		
LABEL	QTY	NUMBER
A	1	W200382
B	1	W200383
C	1	W200384
D	1	W200385
E	1	W200386
F	2	W200379
G	2	W200387
H	1	S220715
I	1	W200388
J	2	W200389
K	1	W200390
L	1	W200391
M	2	W200392
N	1	S220716

WC81411		
LABEL	QTY	NUMBER
A	1	W122521
B	1	W156321
C	1	W156322
D	1	W113925
E	1	W103081
F	2	W103082
G	2	W113926
H	1	S220717
I	1	W120380
J	2	W113927
K	1	W177873
L	1	W103087
M	2	W113928
N	1	S220718

WC81511		
LABEL	QTY	NUMBER
A	1	W193896
B	1	W193897
C	1	W193898
D	1	W193899
E	1	W193900
F	2	W193889
G	2	W193901
H	1	S220719
I	1	W193902
J	2	W193903
K	1	W193904
L	1	W193905
M	2	W193906
N	1	S220720

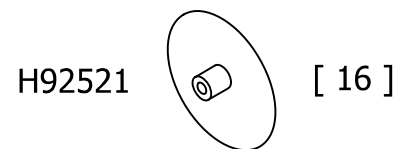
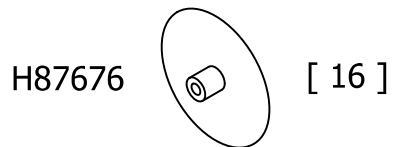
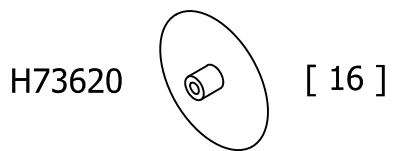
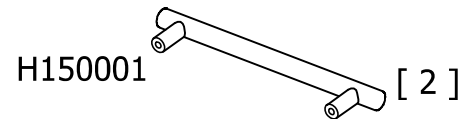
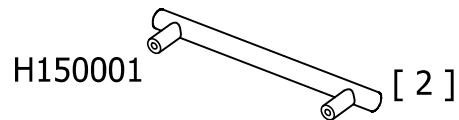
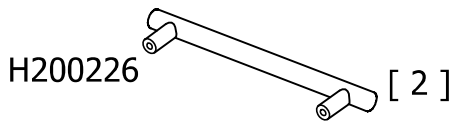

Parts - Pièces - Piezas

WC81611		
LABEL	QTY	NUMBER
A	1	W189180
B	1	W189181
C	1	W189182
D	1	W189183
E	1	W189184
F	2	W189139
G	2	W189185
H	1	S220721
I	1	W189186
J	2	W189187
K	1	W189188
L	1	W189189
M	2	W189190
N	1	S220722

WC81711		
LABEL	QTY	NUMBER
A	1	W145245
B	1	W156323
C	1	W156324
D	1	W145249
E	1	W145250
F	2	W145248
G	2	W145251
H	1	S220723
I	1	W145255
J	2	W145252
K	1	W177874
L	1	W145254
M	2	W145253
N	1	S220724

WC81811		
LABEL	QTY	NUMBER
A	1	W177536
B	1	W177537
C	1	W177538
D	1	W177539
E	1	W177540
F	2	W177514
G	2	W177541
H	1	S220725
I	1	W177542
J	2	W177543
K	1	W177875
L	1	W177545
M	2	W177546
N	1	S220726

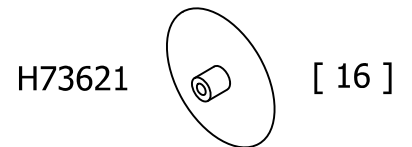
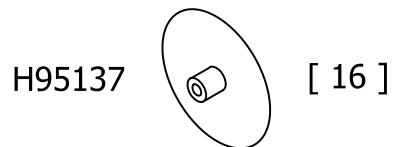
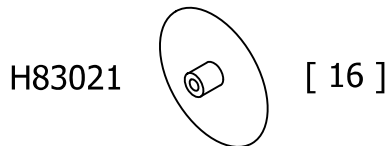
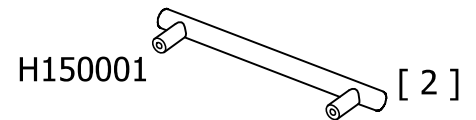
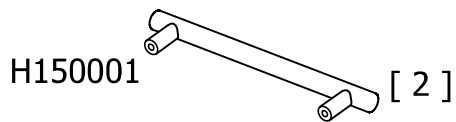
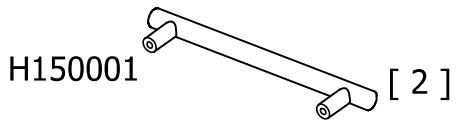

Parts - Pièces - Piezas

WC81911		
LABEL	QTY	NUMBER
A	1	W196064
B	1	W196065
C	1	W196066
D	1	W196067
E	1	W196068
F	2	W196061
G	2	W196069
H	1	S220709
I	1	W196070
J	2	W196071
K	1	W196072
L	1	W196073
M	2	W196074
N	1	S220710

