

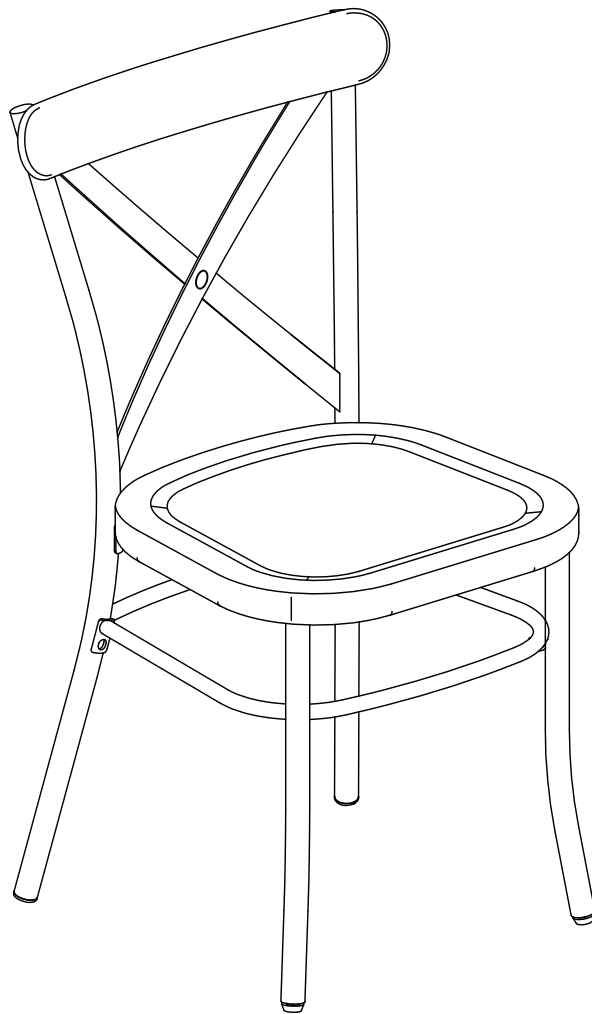

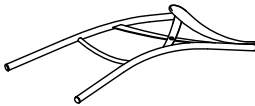





Dining Chair

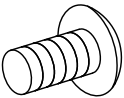

PART LIST

| | | | |
|---|---|---|--|
| <div data-bbox="129 120 177 165" style="border: 1px solid black; padding: 2px;">A</div>  | <div data-bbox="400 120 448 165" style="border: 1px solid black; padding: 2px;">B</div>  | <div data-bbox="670 120 718 165" style="border: 1px solid black; padding: 2px;">C</div>  | <div data-bbox="940 120 987 165" style="border: 1px solid black; padding: 2px;">D</div>  |
| <p style="text-align: center;">Back 1 PC</p> | <p style="text-align: center;">Seat 1 PC</p> | <p style="text-align: center;">Stretcher 1 PC</p> | <p style="text-align: center;">Front Leg 2 PCS</p> |





HARDWARE LIST

| | | | |
|--|---|---|---|
| <div data-bbox="129 656 177 701" style="border: 1px solid black; padding: 2px;">#1</div>  <p style="text-align: center;">1/4"x5/8"L</p> | <div data-bbox="400 656 448 701" style="border: 1px solid black; padding: 2px;">#2</div>  <p style="text-align: center;">$\phi 10.5 \times \phi 7.0 \times 1.5$</p> | <div data-bbox="670 656 718 701" style="border: 1px solid black; padding: 2px;">#3</div>  <p style="text-align: center;">$\phi 16 \times \phi 7.0 \times 1.5$</p> | <div data-bbox="940 656 987 701" style="border: 1px solid black; padding: 2px;">#4</div>  <p style="text-align: center;">M4</p> |
| <p style="text-align: center;">Bolt 10 PCS (Extra 1)</p> | <p style="text-align: center;">Spring Washer 10 PCS (Extra 1)</p> | <p style="text-align: center;">Flat Washer 10 PCS (Extra 1)</p> | <p style="text-align: center;">Allen Wrench 1 PC</p> |

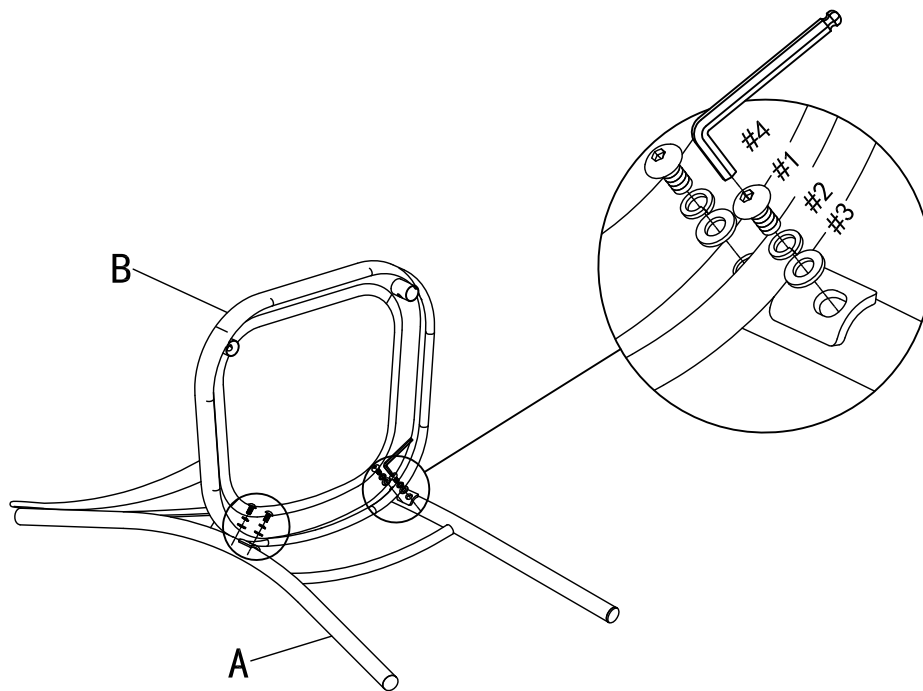
Step 1. Lay back (part A) down on a soft flat surface, such as carpet. Attach seat (part B) to back (part A) using bolts (part #1), spring washers (part #2), flat washers (part #3) and allen wrench (part #4).

NOTE: Please do not fully tighten bolts until unit is fully assembled.





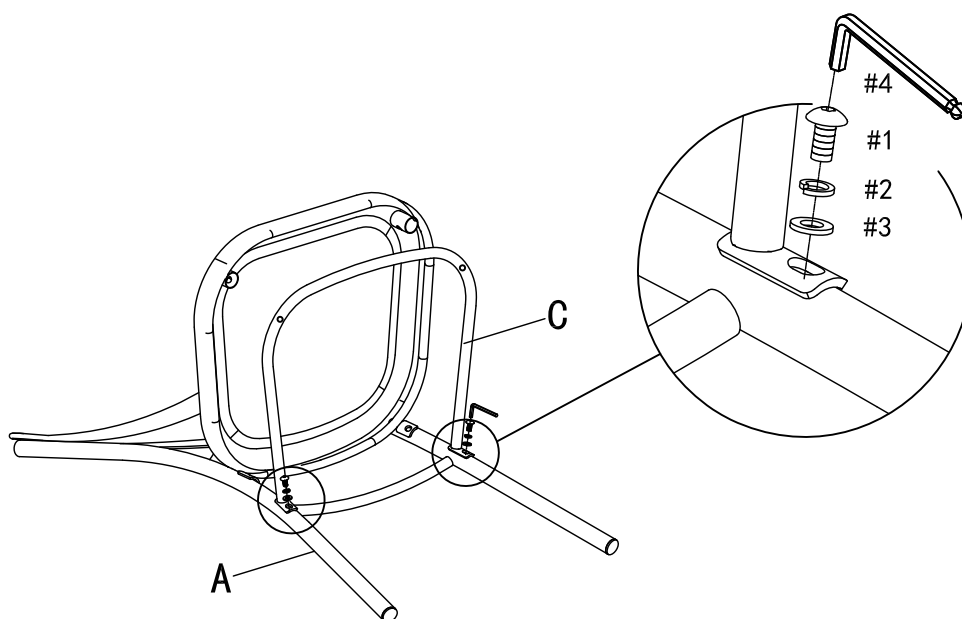

- #1  x 4
- #2  x 4
- #3  x 4
- #4  x 1

Step 2. Attach stretcher (part C) to back (part A) using bolts (part #1), spring washers (part #2), flat washers (part #3) and allen wrench (part #4).

NOTE: Please do not fully tighten bolts until unit is fully assembled.



- #1  x 2
- #2  x 2
- #3  x 2
- #4  x 1

Step 3. Attach front legs (part D) to seat (part B) and stretcher (part C) using bolts (part #1), spring washers (part #2), flat washers (part #3) and allen wrench (part #4).

NOTE: Please fully tighten all bolts at this time.

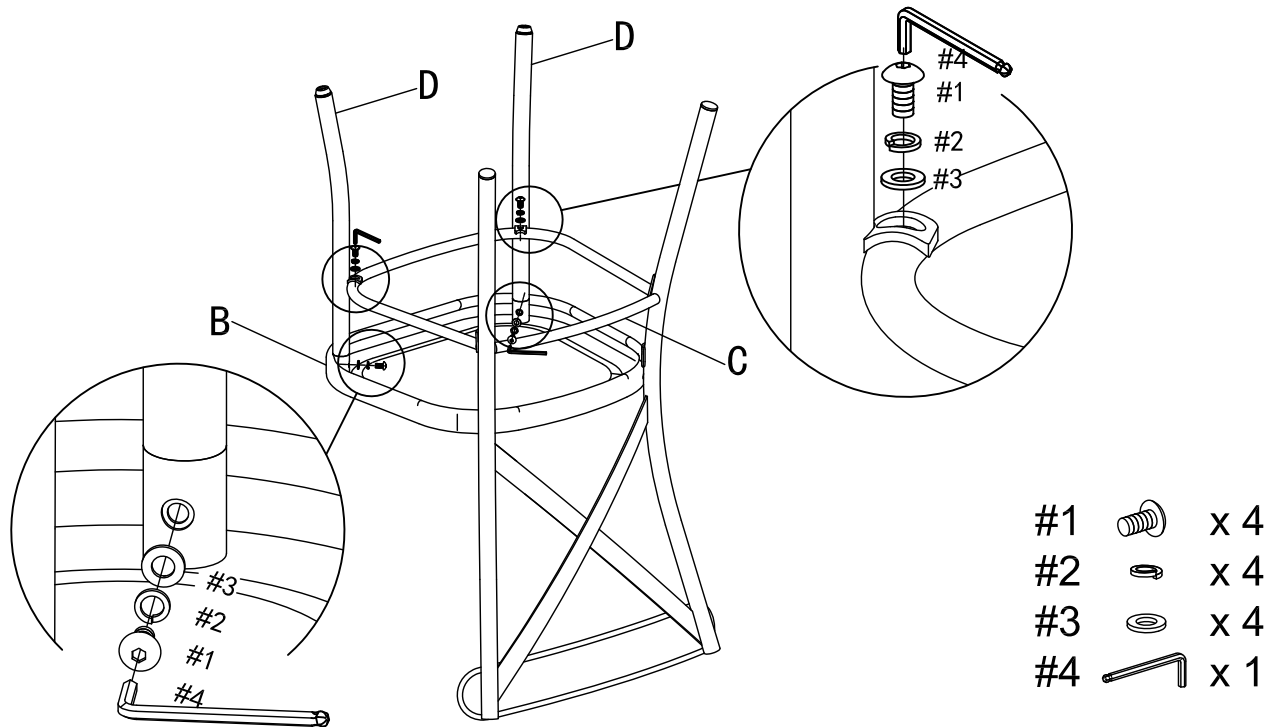

Step 4. Carefully turn unit upright. Repeat steps 1-3 to assemble remaining chair.

