

NOTICE

*Please make sure that you have all parts indicated and they are in good condition before you begin assembly of this item. Refer to part list and hardware list below for guidance.

*This item should be assembled on a soft surface to prevent scratching the finish during assembly.

*This item may require periodic tightening.

*If you are having difficulty, our friendly Customer Care team is always here to help.

PREPARATION

*Before beginning assembly of product, make sure all parts are present. Compare parts with part contents list and hardware contents list.

*If any part is missing or damaged, do not attempt to assemble the product.

*Estimated Assembly Time: 60 minutes.

*Tools Required for Assembly (included): Allen Key

CARE AND MAINTENANCE

Always use felt pads under all articles to prevent discoloration or softening of the lacquer. Plastic and rubber bases on items can discolor wood. Wipe up spills immediately and avoid common hazards such as hot dishes, harsh solvents and abrasives. Cleaning should be done with a soft lint free cotton cloth dampened with water or furniture polish. On highly used surfaces we recommend applying a quality paste wax which should be used on a regular basis to provide additional protection from scratches and spills. How often you apply the wax depends on how much wear the furniture receives.

Part List

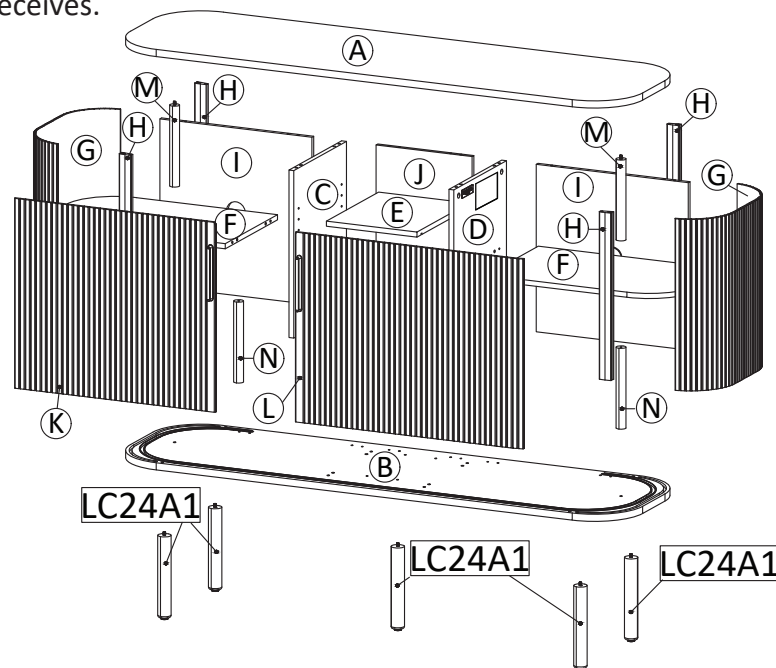

Product Dimensions: 63"Wx18"Dx31"H

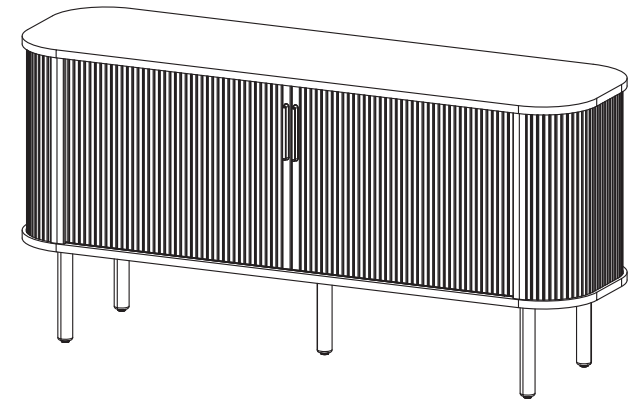











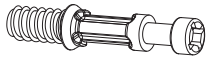

WARNING :

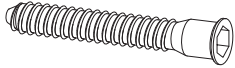
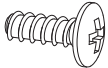
WEIGHT CAPACITY: 104 LBS.

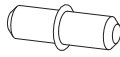
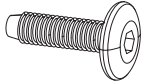
Warning : Do not stand on media stand.

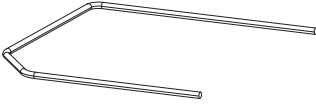
Warning : Do not over torque bolts.

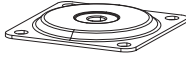
Hardware List

<p>HW1x20</p>  <p>∅ 6 x 35 mm</p>	<p>HW2x8</p>  <p>∅ 15 mm</p>	<p>HW3x12</p>  <p>∅ 12 mm</p>	<p>HW4x12</p>  <p>∅ 8 x 30 mm</p>	<p>HW5x28</p>  <p>∅ 6 x 30 mm</p>
<p>HW6x4</p>  <p>M 7 x 50 mm</p>	<p>HW7x28</p>  <p>M 4.5 x 12.5 mm</p>	<p>HW8x4</p>  <p>M 4 x 10 mm</p>	<p>HW9x4</p> 	<p>HW10x2</p>  <p>M 6 x 30 mm</p>
<p>HW11x2</p> 	<p>HW12x2</p> 	<p>HW13x2</p> 	<p>HW14x4</p>  <p>∅ 15 mm</p>	<p>HW PM2x5</p> 
<p>HW PM3x2</p> 				

Part List & HW For Multi-Box Items

Piece	Description	Qty
A	Top Board	1
B	Bottom Board	1
C	Center Board Left	1
D	Center Board Right	1
E	Adjustable Shelf	1
F	Fixed Shelf	2
G	Bar Side	2
H	Support Board	4
I	Back Board 1	2
J	Back Board 2	1
K	Door Left	1
L	Door Right	1
M	Pillar 1	2
N	Pillar 2	2
LC24A1	Leg	5

Piece	Description	Qty
HW1	Cambolt	20
HW2	CamLock Big	8
HW3	CamLock Small	12
HW4	Dowel Big	12
HW5	Dowel Small	28
HW6	Screw M 7 x 50 mm	4
HW7	Screw M 4.5 x 12.5 mm	28
HW8	Screw M 4 x 10 mm	4
HW9	Shelf Pin	4
HW10	Screw M 6 x 30 mm	2
HW11	Allen Key	2
HW12	Handle	2
HW13	Divider Wire	2
HW14	Screw Cap	4
HW PM2	Mounting Plate	5
HW PM3	Mounting Plate	2

PREPARATION

- *Before beginning assembly of product, make sure all parts are present. Compare parts with part contents list and hardware contents list.
- *If any part is missing or damaged, do not attempt to assemble the product.
- *Estimated Assembly Time: 60 minutes.
- *Tools Required for Assembly (included): Allen Key
- *If you are having difficulty, our friendly Customer Care team is always here to help.

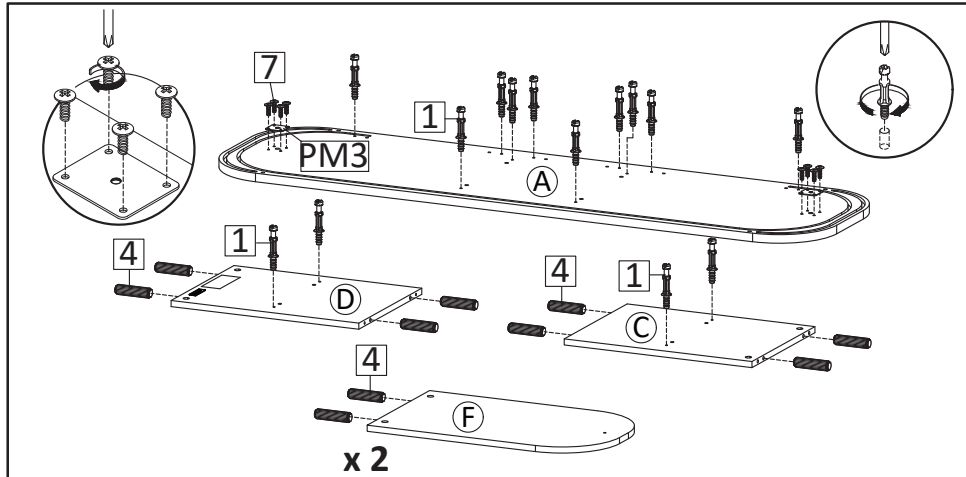

STEP1: Insert Cambolt (HW1) into Top Board (A), Center Board Left (C) and Center Board Right (D). Insert Mounting Plate (HW PM3) to Top Board (A) secure with Screw M4.5x12.5mm (HW7). Insert Dowel Big (HW4) into Fixed Shelf (F).

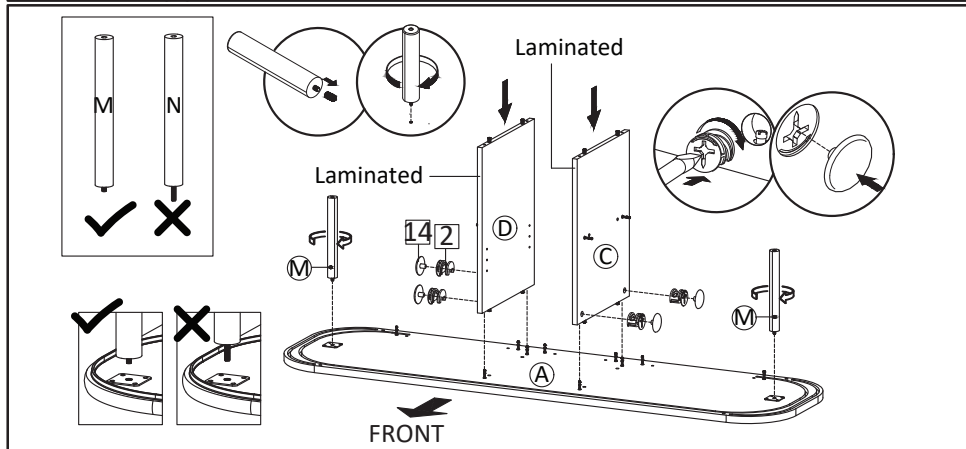

STEP3: Attach Center Boards (C&D) into Top Board (A) with laminated edge facing front. Insert Camlock Big (HW2) then tighten using screwdriver. Put Screw Cap (HW14) over the camlock. Pillar 1 (M) has shorter bolt compare to Pillar 2 (N). Please make sure install correct Pillar (M) into the Mounting Plate, tighten by rotating clockwise.

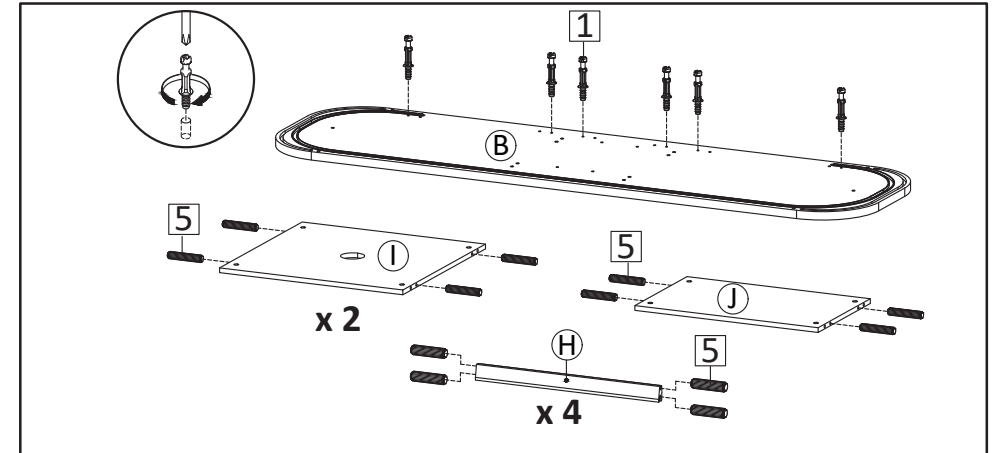

STEP2: Insert Cambolt (HW1) into Bottom Board (B). Insert Dowel Small (HW5) into Support Board (H) and Back Boards (I&J) as figure.

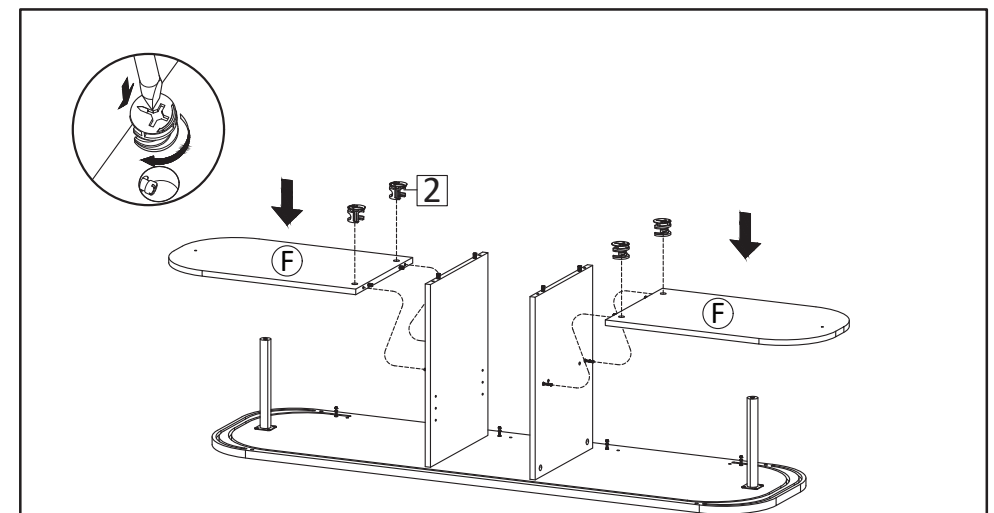

STEP4: Attach Fixed Shelf (F) into Center Boards. Insert Camlock (HW2) then tighten using screwdriver as picture.

PREPARATION

- *Before beginning assembly of product, make sure all parts are present. Compare parts with part contents list and hardware contents list.
- *If any part is missing or damaged, do not attempt to assemble the product.
- *Estimated Assembly Time: 60 minutes.
- *Tools Required for Assembly (included): Allen Key
- *If you are having difficulty, our friendly Customer Care team is always here to help.

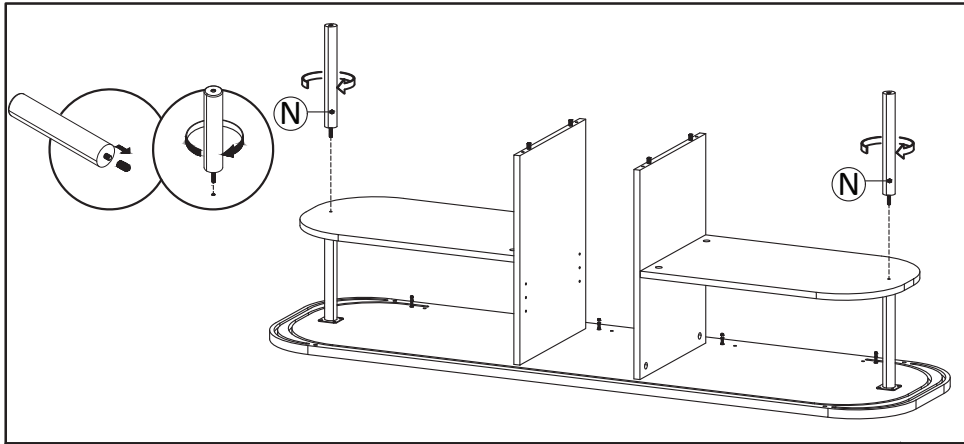

STEP5 : Insert Pillar 2 (N) into Top Board position as the above image.

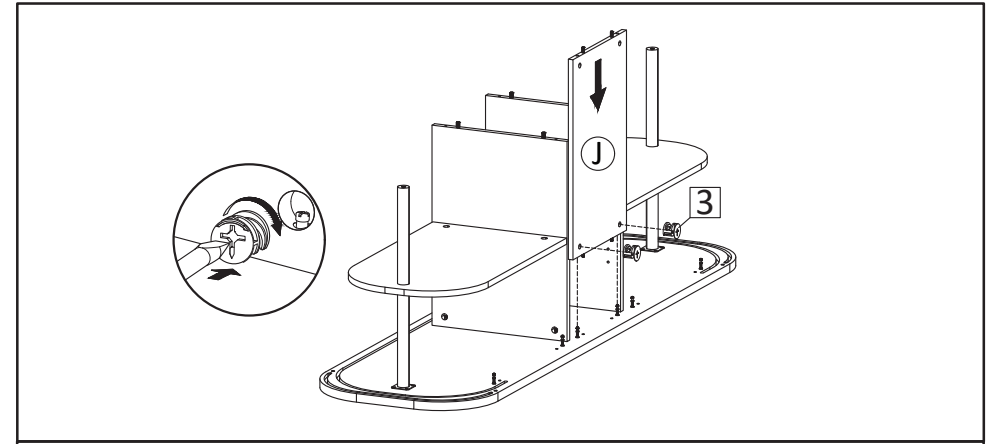

STEP6: Attach Back Board 2 (J) into Top Board (A). Insert Camlock (HW3) then tighten using screwdriver.

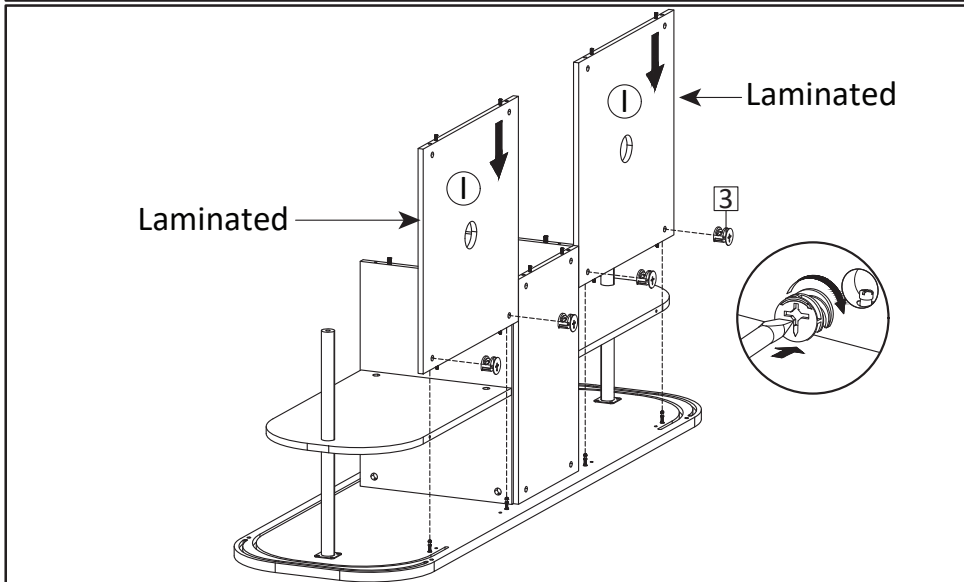

STEP7: Attach Back Board 1 (I) into Top Board (A). Insert Camlock (HW3) then tighten using screwdriver as figure.

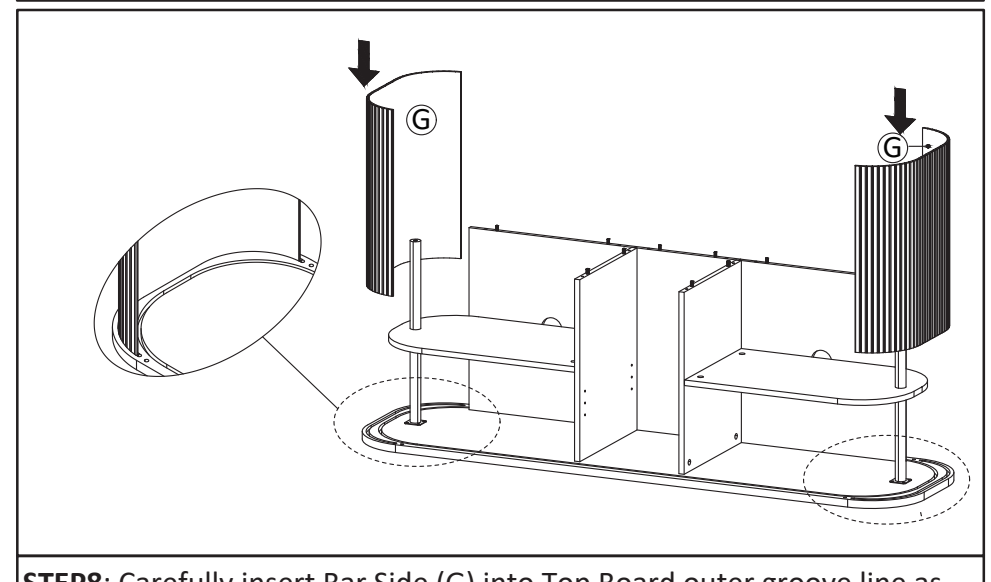

STEP8: Carefully insert Bar Side (G) into Top Board outer groove line as above image.

PREPARATION

- *Before beginning assembly of product, make sure all parts are present. Compare parts with part contents list and hardware contents list.
- *If any part is missing or damaged, do not attempt to assemble the product.
- *Estimated Assembly Time: 60 minutes.
- *Tools Required for Assembly (included): Allen Key
- *If you are having difficulty, our friendly Customer Care team is always here to help.

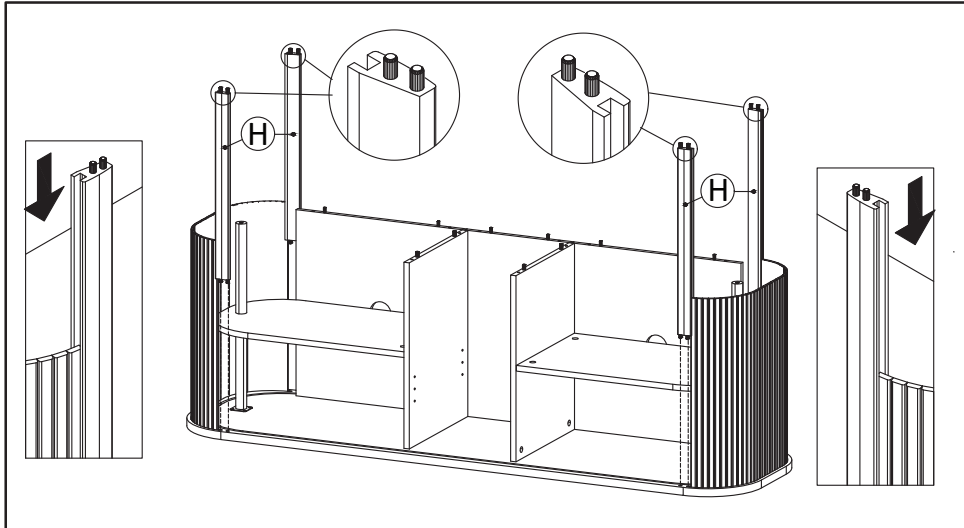

STEP9: Insert Support Board (H) into Top Board. Please notice the grooved side must be placed facing the Bar Side.

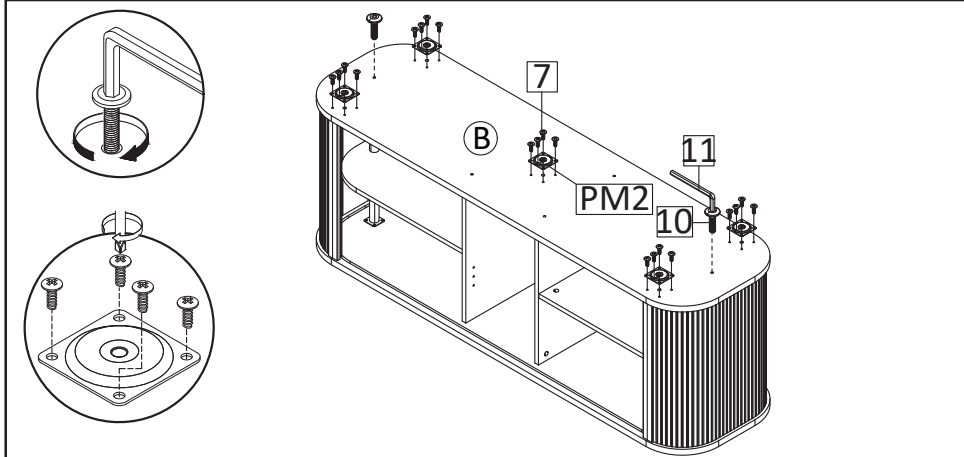

STEP11: Insert Screw M6x30mm (HW10), tighten using Allen Key (HW11) to secure Pillar (N). Install Mounting Plate (HW PM2) and secure with screw M4.5x12.5mm (HW7) on Bottom Board.

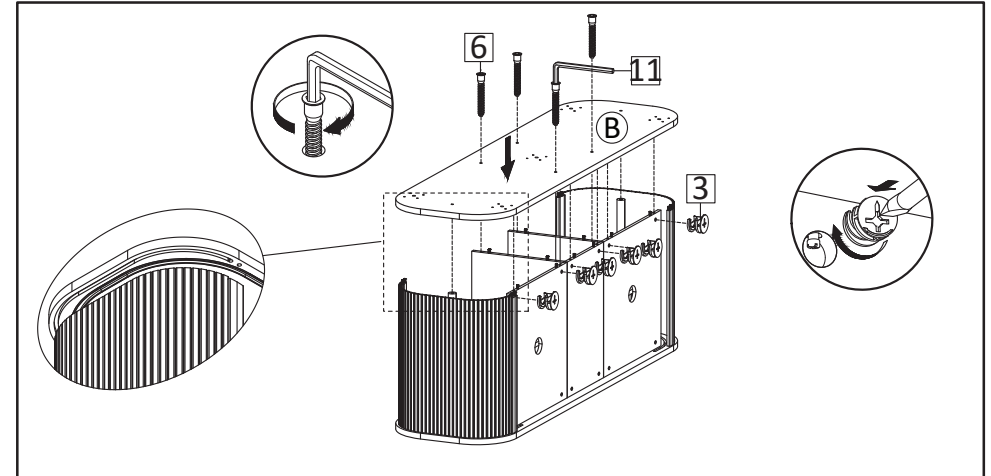

STEP10: Place Bottom Board (B) onto main assembled unit. Ensure the Bar Side has been properly inserted into the outer groove line of the Bottom Board. Use Screw M7x50mm (HW6) to secure Bottom Board, tighten screws using Allen Key (HW11) as figure. Insert Camlock Small (HW3) to Back Board then tighten using screwdriver as figure.

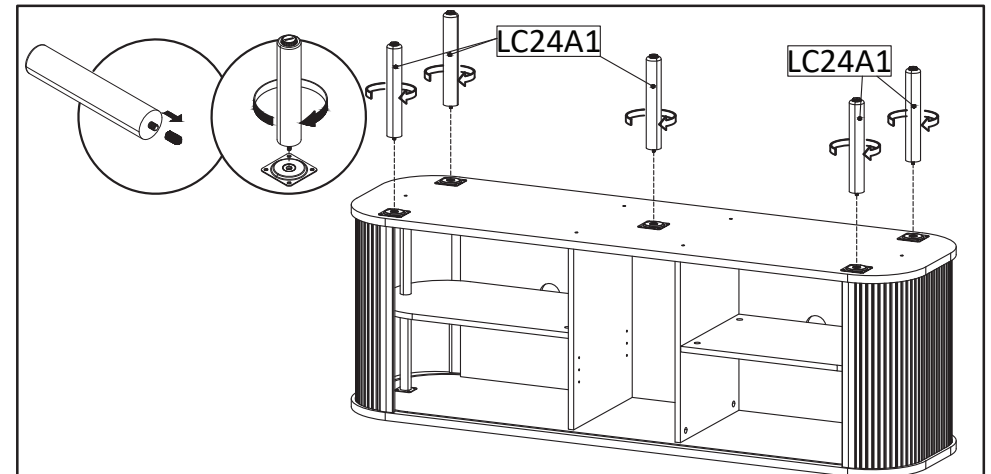

STEP12: Install Leg (LC24A1) into Mounting Plate, tighten by rotating the leg clockwise.

PREPARATION

*Before beginning assembly of product, make sure all parts are present. Compare parts with part contents list and hardware contents list.

*If any part is missing or damaged, do not attempt to assemble the product.

*Estimated Assembly Time: 60 minutes.

*Tools Required for Assembly (included): Allen Key

*If you are having difficulty, our friendly Customer Care team is always here to help.

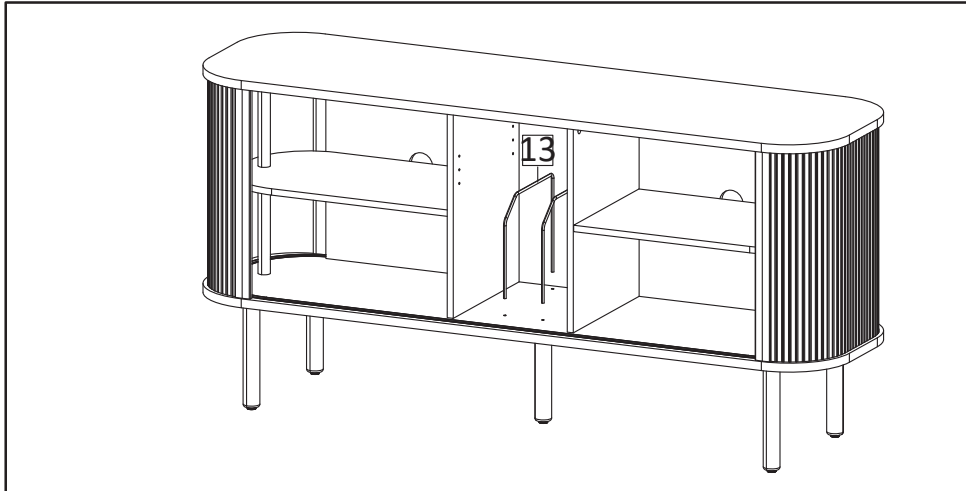

STEP13: Insert Divider Wire (HW13) into Bottom Board,ensure the wire has been properly inserted into the provided hole.

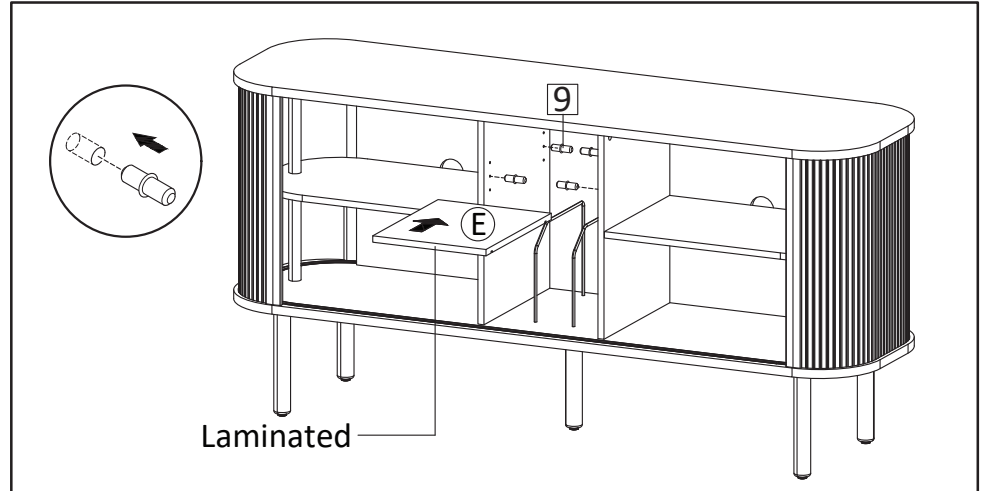

STEP14: Insert Shelf Pin (HW9) into the holes on Center Boards, on the desired level.Then place the Adjustable Shelf (E) onto shelf pin.

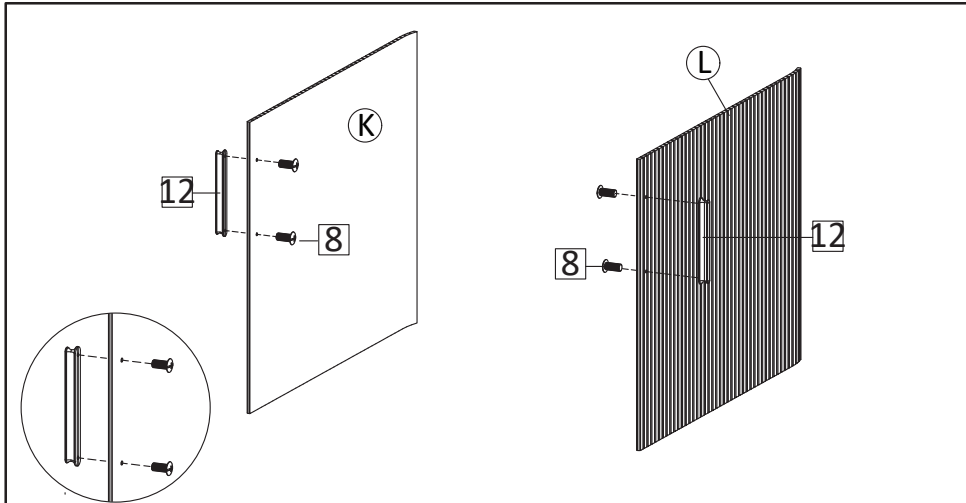

STEP15: Insert Handle (HW12) into the holes on Doors (K&L),secure with Screw M4x10mm (HW8).

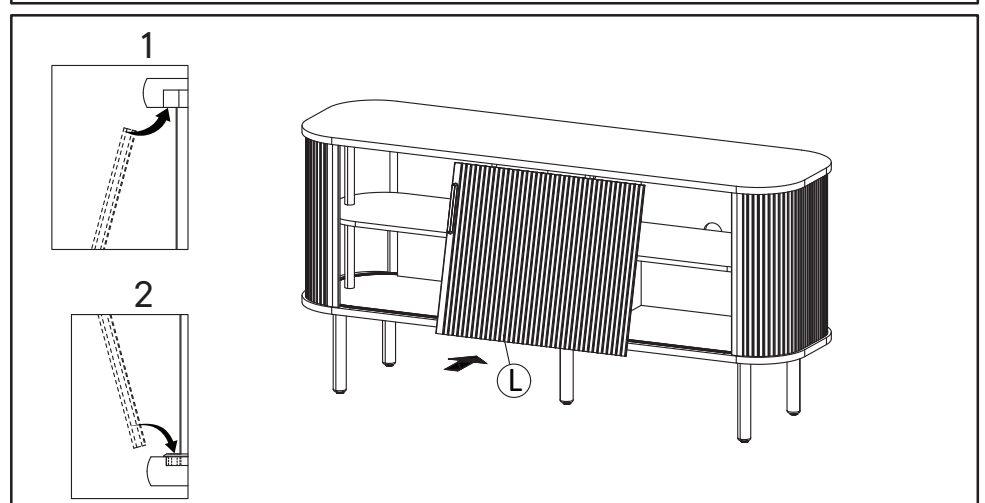

STEP16: Insert the Door Right (L) into the upper groove line, hold then align the lower side of door to properly placed inside the bottom track.

PREPARATION

- *Before beginning assembly of product, make sure all parts are present. Compare parts with part contents list and hardware contents list.
- *If any part is missing or damaged, do not attempt to assemble the product.
- *Estimated Assembly Time: 60 minutes.
- *Tools Required for Assembly (included): Allen Key
- *If you are having difficulty, our friendly Customer Care team is always here to help.

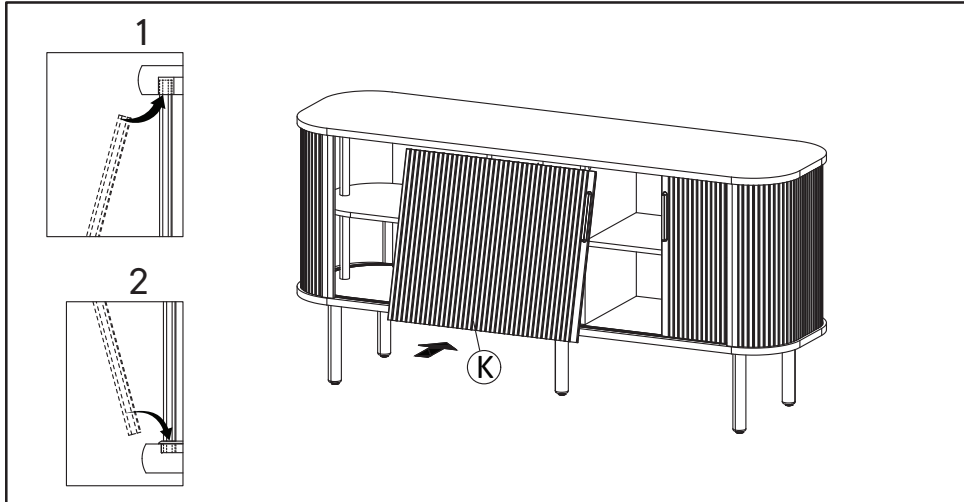

STEP17: Please repeat step 16 for the Door Left (K).

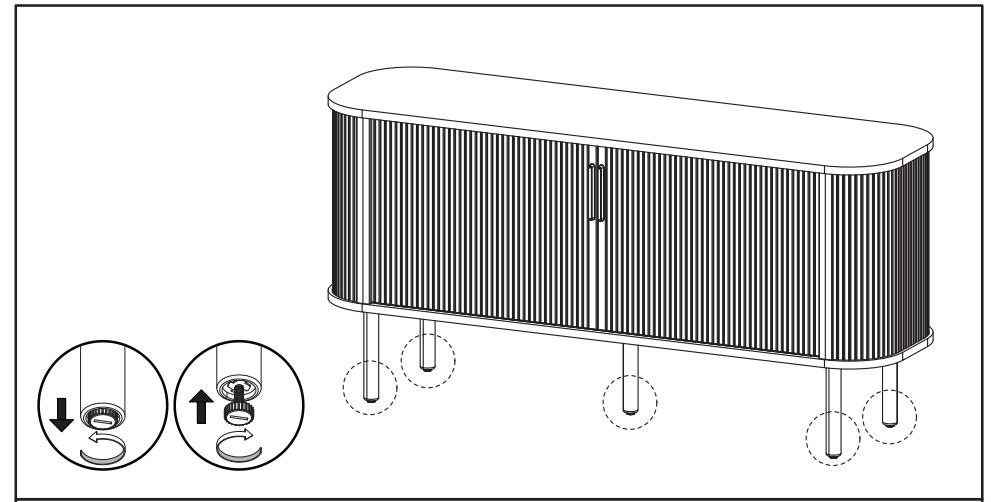

STEP18: Place your furniture on level floor. The legs come with adjustable leveler, adjust it as needed until your furniture stands steadily on the floor. Assembly is Complete.

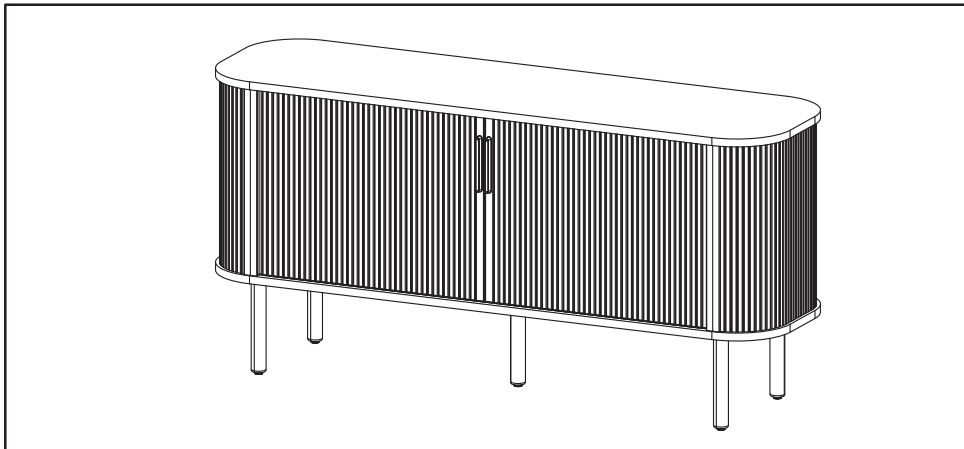

STEP19: Assembly is Complete.

TIPPING RESTRAINTS KIT INSTALLATION GUIDANCE

Different wall materials require unique wall fasteners.

The wall plugs (AA2) and screws (AA3) are designed for fixing to concrete walls only.

Please consult your local hardware store to ensure you are using the correct hardware for your wall type.

