

# ASSEMBLY INSTRUCTIONS FOR ACME FURNITURE





## MODEL#72205T&72206ST





Thank you for purchasing the quality product. Be sure to check all packing material carefully for small parts which may have come loose inside the carton during shipment. Separate, identify and count all parts and metal hardware. Compare with all parts list to be sure all parts are present. If any part(s) are missing or damaged, please contact your local furniture dealer. For efficient and speedy service, please indicate the model number and code letter of part(s) needed

\*\*\* Do not fully tighten screws until fully assembled \*\*\*

### COMPONENT PARTS

### HARDWARE REQUIRED

| NO | DESCRIPTION    | SKETCH  | QTY  |
|----|----------------|---|------|
| Ⓐ  | TABLE TOP      |  | 1 Pc |
| Ⓑ  | PEDESTAL       |  | 1 Pc |
| Ⓒ  | MOUNTING PANEL |  | 1 Pc |
| Ⓓ  | PEDESTAL BASE  |  | 1 Pc |

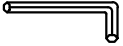
| NO | DESCRIPTION                 | SKETCH  | QTY    |
|----|-----------------------------|---|--------|
| ①  | Bolt (Ø5/16" * 63mm)        |  | 4 Pcs  |
| ②  | Bolt (Ø5/16" * 38mm)        |  | 8 Pcs  |
| ③  | Spring Washer (Ø5/16" * 13) |  | 12 Pcs |
| ④  | Flat Washer (Ø5/16" * 19)   |  | 12 Pcs |
| ⑤  | Allen Key M4                |  | 1 Pc   |

**Attention**  
 \*\*\*Some number parts listed on the instruction sheet may not be in parts bag as they may be assembled. Carefully check parts and packing materials prior to ordering replacements.\*\*\*

#### STEP 1

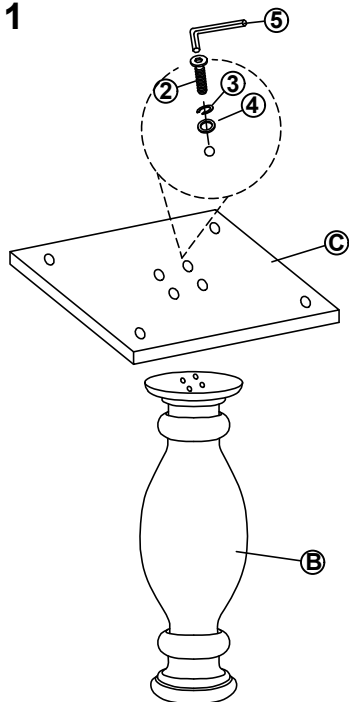

#### STEP 2

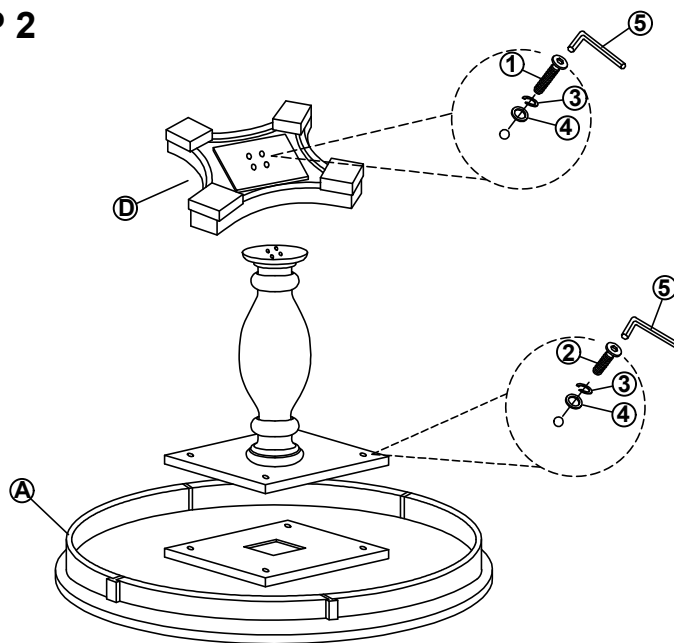

#### STEP 3

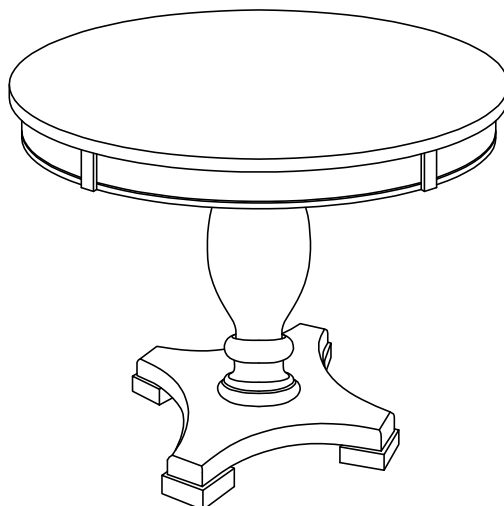







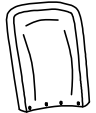

# ASSEMBLY INSTRUCTIONS

## MODEL: 72202

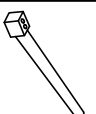
Important note :

- Place all wooden parts on a clean and smooth surface such as a rug or carpet to avoid scratching the parts.
- Kindly follow the assembly instructions step by step.
- Do not tighten all screws and bolts until the chair is fully assembled.

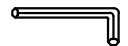
| PARTS LIST |             |   |       | HARDWARE LIST |               |   |        |
|------------|-------------|---|-------|---------------|---------------|---|--------|
| NO         | DESCRIPTION | SRETCH  | QTY   | NO            | DESCRIPTION   | SRETCH  | QTY    |
| A          | CHAIR BACK  |  | 1 Pc  | 1             | LONG BOLT     |  | 8 Pcs  |
| B          | CUSHION     |  | 1 Pc  | 2             | SHORT BOLT    |  | 4 Pcs  |
| C          | BACK LEG    |  | 2 Pcs | 3             | SPRING WASHER |  | 12 Pcs |
| D          | FRONT LEG   |  | 2 Pcs | 4             | FLAT WASHER   |  | 12 Pcs |
|            |             |   |       | 5             | ALLEN KEY     |  | 1 Pc   |

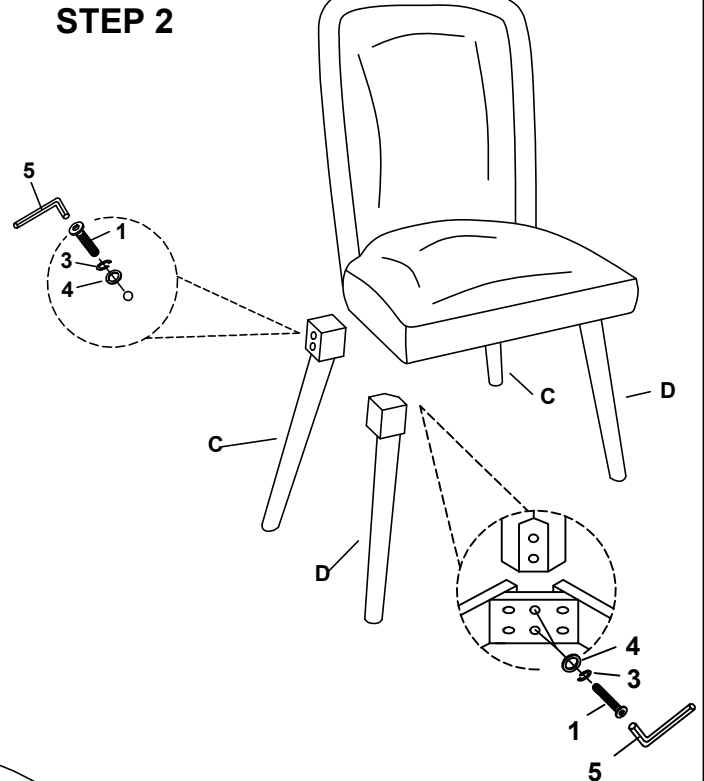
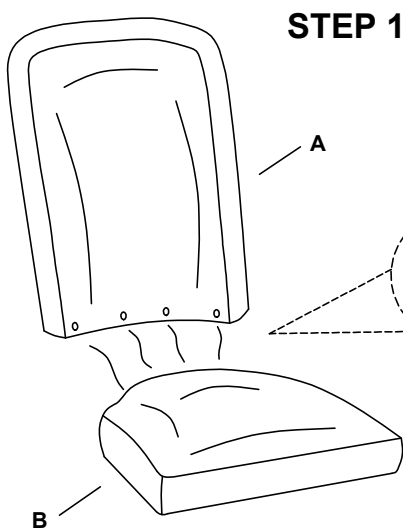

**STEP 3**

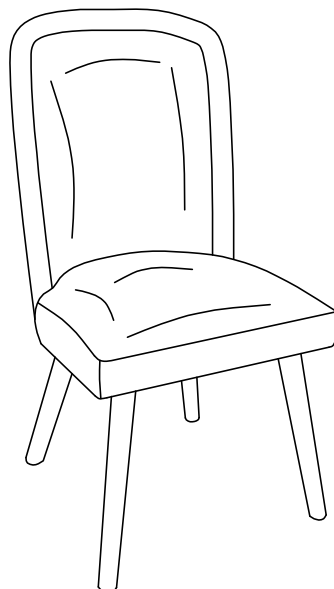

**Made in Viet Nam**