

ASSEMBLY INSTRUCTIONS

4'6" BED

IMPORTANT: READ THESE INSTRUCTIONS CAREFULLY BEFORE ASSEMBLING OR USING YOUR 4'6" BED FRAME.

PLEASE KEEP THESE INSTRUCTIONS FOR FUTURE REFERENCE.

HEALTH & SAFETY :

DO NOT jump on this bed frame.

DO NOT use this bed frame if any parts are missing, damaged or worn.

DO NOT use this bed frame unless all fixings are secured.

Please keep small parts out of reach of children.

Always use on a level, even surface.

WARNING: If this bed is placed on a non-carpeted floor you must place some protection under all legs to stop the bed frame from moving. If this is not adhered to there is no guarantee if the bed frame collapses.

CARE & MAINTENANCE:

Assemble in the room of use.

Periodically check all screws & fixings to ensure they are secure.



DO NOT push the bed frame as this will damage the legs.

Always lift the bed with two people to reposition.

Keep any sharp objects away from the frame.

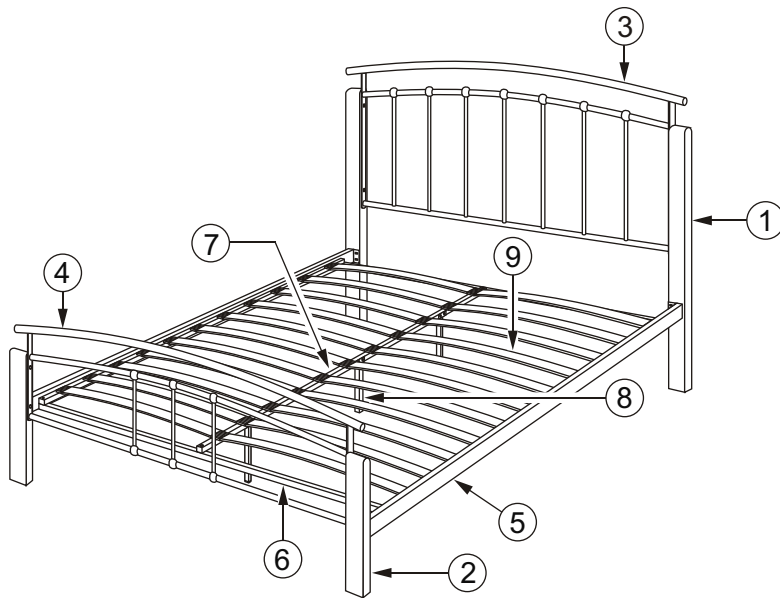



PART LIST				HARDWARE LIST (FOUND IN BOX 1)			
PART	DESCRIPTION	BOX	QTY	PART	DESCRIPTION		QTY
1	Headpost (L/R)	2	2	A	M6 x 20mm JCBC Screw		16
2	Footpost (L/R)	2	2	B	M6 x 50mm JCBC Screw		4
3	Headend	1	1	C	M6 x 35mm JCBC Screw		6
4	Footend	1	1	D	M6 Nut		10
5	Side Support	3	2	E	Double Slat Cap		11
6	Side Frame	3	2	F	Single Slat Cap		22
7	Mid Support	3	1	G	M8 x 50mm JCBC Screw		2
8	Base Leg	1	3	H	M8 Nut		2
8	Slat	4	22	** M4 & M5 Allen Key Supplied			

Step 1: Fix the headposts (1) to the headend (3) then attach the footposts (2) to the footend (4) using hardware part (A). **DO NOT** use any power tools as this may damage the frame and will invalidate any claim.

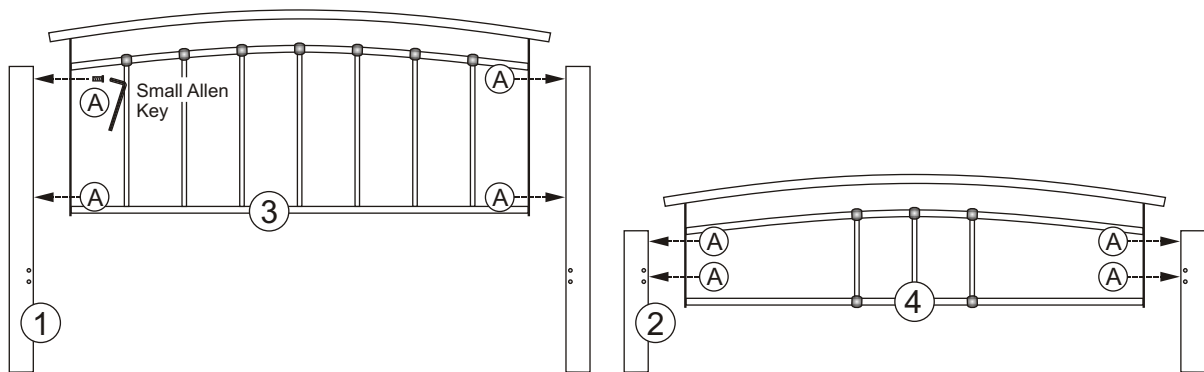

Step 2: Fix the Side Support (5) to the Headposts (1) and Footposts (2) using hardware parts (A).
DO NOT use any power tools as this may damage the frame and will invalidate any claim.

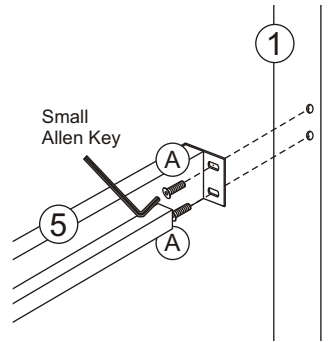

Step 3: Place the Side Frame (6) at the bottom of the Side Support (5) using hardware parts (B) and (D).
DO NOT use any power tools as this may damage the frame and will invalidate any claim.

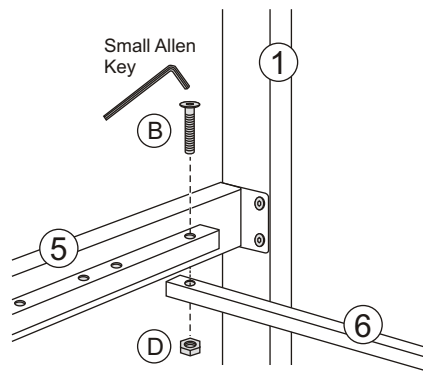

Step 4: Place the Mid Support (7) on top of both Side Frames (6) and secure using hardware parts (G) and (H).
DO NOT use any power tools as this may damage the frame and will invalidate any claim.

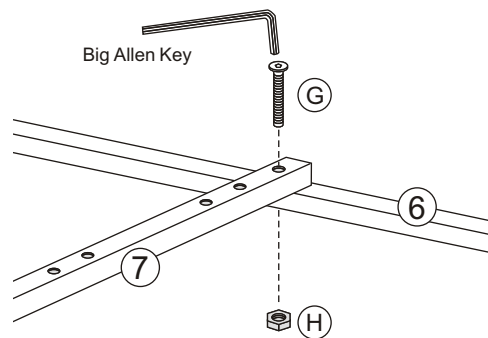

Step 5: Fit the Base Legs (8) to the Mid Support (7) according to the holes at the side and tightly secure using hardware parts (C) and (D).
DO NOT use any power tools as this may damage the frame and will invalidate any claim.

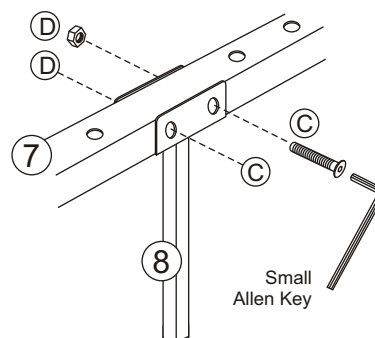

Step 6: Adjust both of the Side Supports (5) into inner direction until the screws reach the end of the hole as shown. Tighten the screws for the Side Supports and the Mid Support. **DO NOT use any power tools as this may damage the frame and will invalidate any claim.**

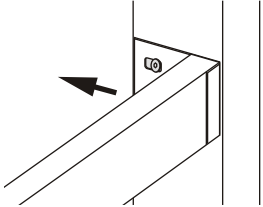

Step 7: Press hardware part (E) into the Mid Support (7) then place hardware part (F) onto an end of every slat (9). **DO NOT use any power tools as this may damage the frame and will invalidate any claim.**

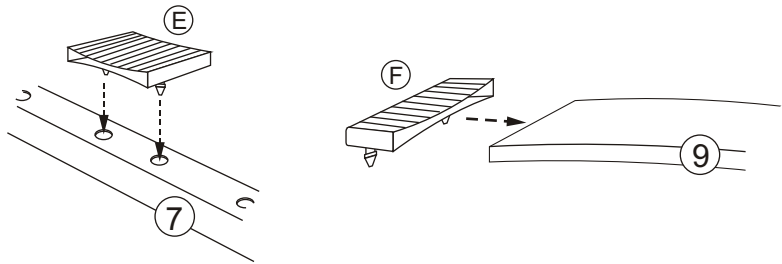

Step 8: Place the Slats (9) into hardware part (E) then press hardware part (F) firmly into the Side Supports (5). **DO NOT use any power tools as this may damage the frame and will invalidate any claim.**

