









Check Components

Zebra Shade Components	Shade Width Up to 39 in	Shade Width 40 in and up
Bracket A 	x 2	x 3
Bracket B 	x 2	x 3
Small Screws 	x 2	x 3
Flat Washer 	x 2	x 3
Hex Nuts 	x 2	x 3
Screws 	x 4	x 6
Anchors 	x 4	x 6
Handle 	x 1	x 1

Prepare necessary tools

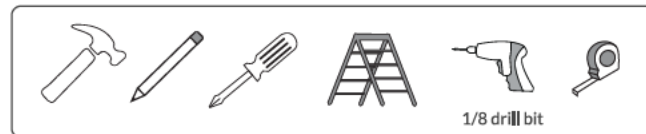

Warning

Avoid operating the shade up & down when the shade is not installed on a wall or in a window frame to prevent fabric sides from fraying.

STEP 1: DETERMINE INSIDE/CEILING, FLUSH, WALL OR OUTSIDE MOUNT

a. Inside/Ceiling or Flush Mount

(A minimum 2 1/4 in. depth is required or 3 1/4 in. depth for flush mounts.)

- 1) Use *bracket A* only and position it approximately 2 inches from the ends of the headrail.
- 2) Mark the pre-drilled holes for the bracket using a pencil. If you have more than 2 brackets, position it equally.
- 3) Use the screws and anchors to install bracket holes.

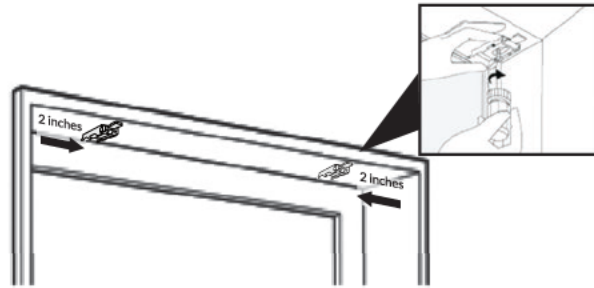

b. Wall or Outside Mount

(A minimum 1 3/8 inch flat wall space is necessary)

- 1) Combine *bracket A & B* by using the small screws, flat washer and hex nuts. (see image below).
- 2) Position brackets approximately 2 inches from the ends of the headrail. If you have more than 2 brackets, position it equally.
- 3) Mark the pre-drilled holes for the bracket using a pencil.
- 4) Use the screws and anchors to install the bracket holes.

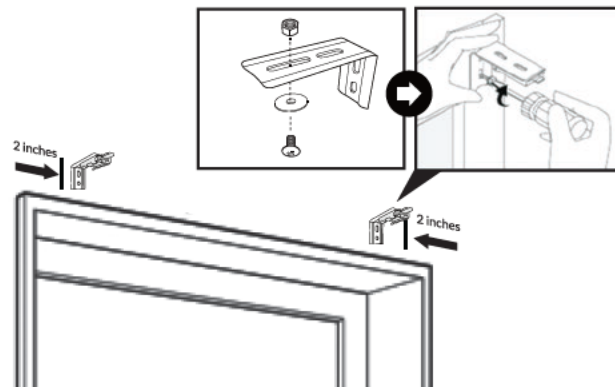

STEP 2: MOUNT THE SHADE IN BRACKET

- 1) Insert the shades under the inner back edge of the bracket.
- 2) Push the tab in on the front of each bracket and rotate the headrail upward until it's completely inserted then release the tab.
- 3) To remove the shade, push the tab again to release the shade while supporting the shade's weight to avoid the shade falling to the floors.

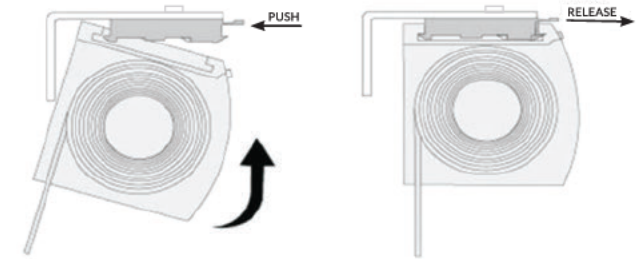

STEP 3: ATTACH THE HANDLE

- 1) Under the bottom rail, insert the handle inside the gap and position it to the middle.
- 2) Push on the top until you hear a "click" sound.

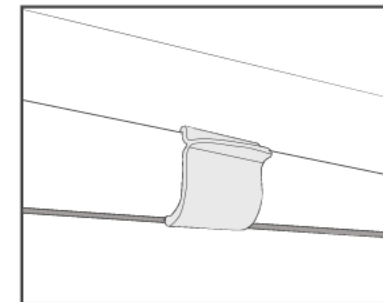
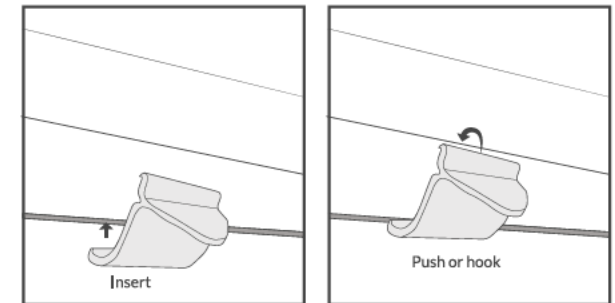

STEP 4: HOW TO OPERATE

To lower the shade: grip the handle and slowly pull straight down.

To raise the shade: grip the handle and lift slowly until the desired height is reached.

Important Note:

Always push and pull at the center of the shade to ensure that the bottom of the shade remains even (i.e. parallel to the top of the shade). If the shade becomes uneven, slowly pull it all the way down, and then lift to the desired position.



CLEANING & CARE

To clean your shade, use a feather duster, microfiber cloth or vacuum lightly using the soft brush attachment



Chicology Ready-Made Blinds Warranty Limited One Year Warranty from the Date of Purchase

What is Covered:

All of our shades are warranted against manufacturer defects in materials or workmanship provided that you are the original purchaser of the product, and the product was installed according to our instructions.

What is Not Covered:

- Normal wear and tear.
- Consumer damages caused by accidents, alternations, abuse of the product, exposure to salt air, misuse, or damages from pets or insects.
- Damages resulting from removal and reinstallation in the same or any other window or application, or failure to follow instructions, such as measurement, installation, cleaning, and maintenance.
- Any products that, with the passage of time, has yellowing or cracking of plastic parts.
- Wrong measurements are not covered by the warranty and are not refundable.

To Report Shipping Damages:

If damage occurred during shipping, please email and call us immediately and report within **14 calendar days** or else you may be denied for your damaged product.

To Obligations to the consumer:

The obligations of Chicology are limited to the repair or replacements of parts or products found to be defective. Chicology will determine if the product is defective or not and may replace the product. If the product is found to have manufacture defects, we will repair or replace the product. Colors do vary from lot to lot, and may not match original product exactly. Discontinued items will be replaced with the most current product of the same price.

Your Rights under State law:

This limited warranty gives you specific legal rights, and you may have other rights, which vary from state to state.

Defective Product:

If you believe your shade has a manufacturing defect, please email and call us.