

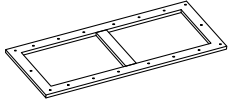

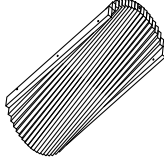

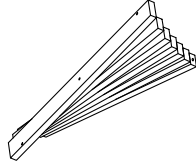
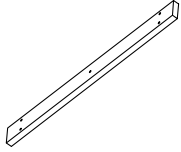

ASSEMBLY INSTRUCTIONS

78" WAVE RIPPLE DINING TABLE

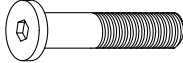
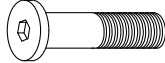
A Table Top  1 pc	B Frame  1 pc	C Leg (Big)  2 pcs	D Leg (Small)  2 pcs
E Connector Support Leg  3 pcs	F Wood Dowel M10 x 25mm  6 pcs	G JCBC Bolt M6 x 40mm  16 pcs	H JCBC Bolt M6 x 25mm  14 pcs
I Spring Washer M6 x 13mm  4 pcs	J Flat Washer M8 x 22mm  4 pcs	K Flat Washer M6 x 13mm  26 pcs	L Screw Adjuster M6 x 23mm  4 pcs
M Allen Key M4 x 100mm  1 pc			

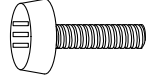
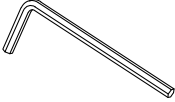
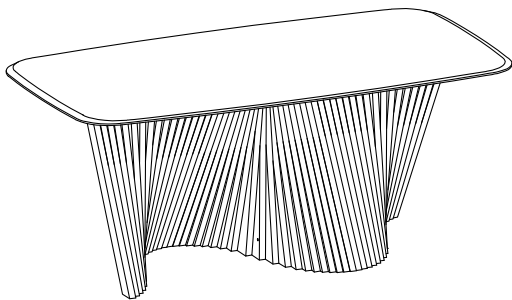

This page lists all the contents included in the box. Please take the time to identify the hardware as well as the individual components to this product. As you unpack and prepare for assembly, place the contents on a carpeted or padded area to protect them from damage.

- 1** Insert Wood Dowel (F) into the Leg (Small) (D).
Tip : Lay the legs down before assembly.

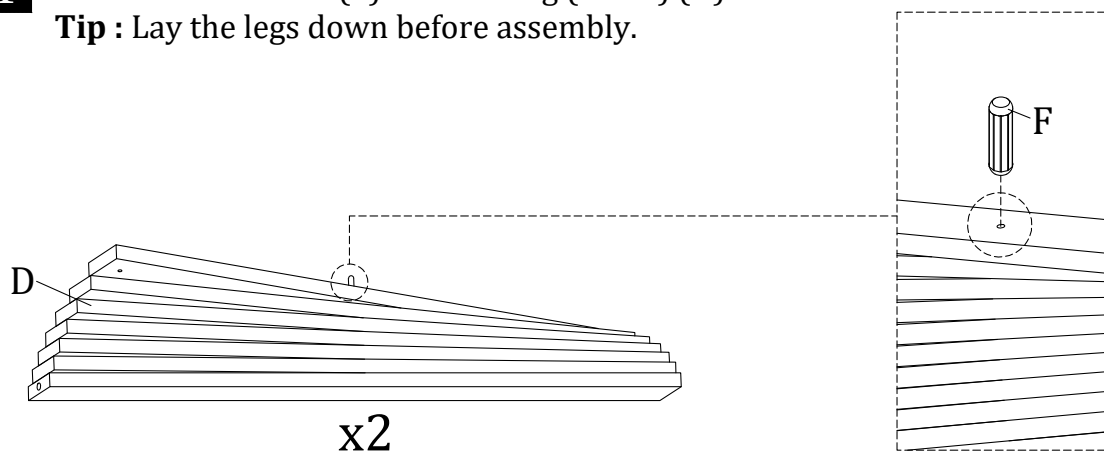

- 2** Attach the Connector Support Leg (E) to the Leg (Small) (D) by using JCBC Bolt (G) and Flat Washer (K) with the Allen Key (M).

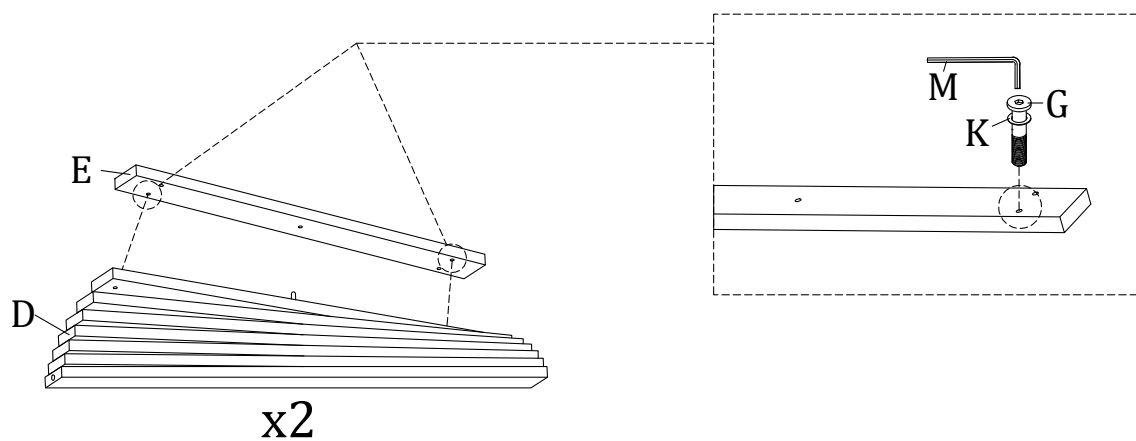

- 3** Insert Wood Dowel (F) into the Leg (Big) (C).

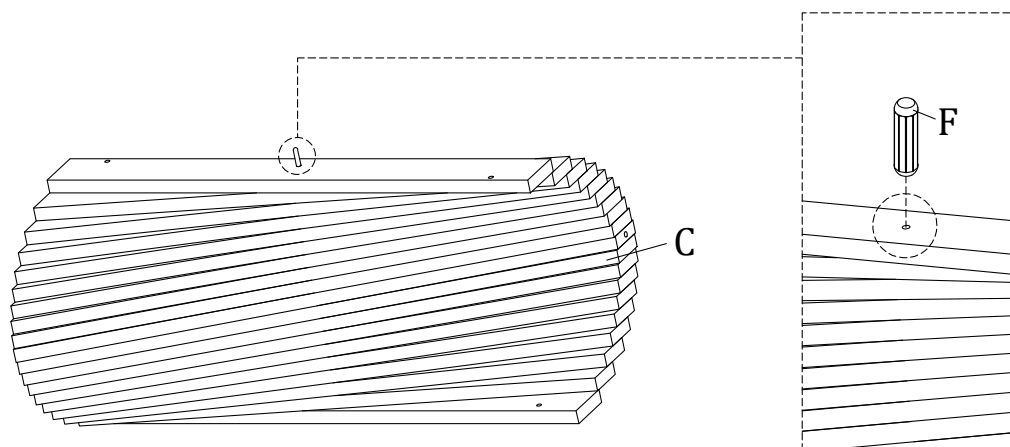

- 4** Attach the Connector Support Leg (E) to the Leg (Big) (C) by using JCBC Bolt (G) and Flat Washer (K) with the Allen Key (M).

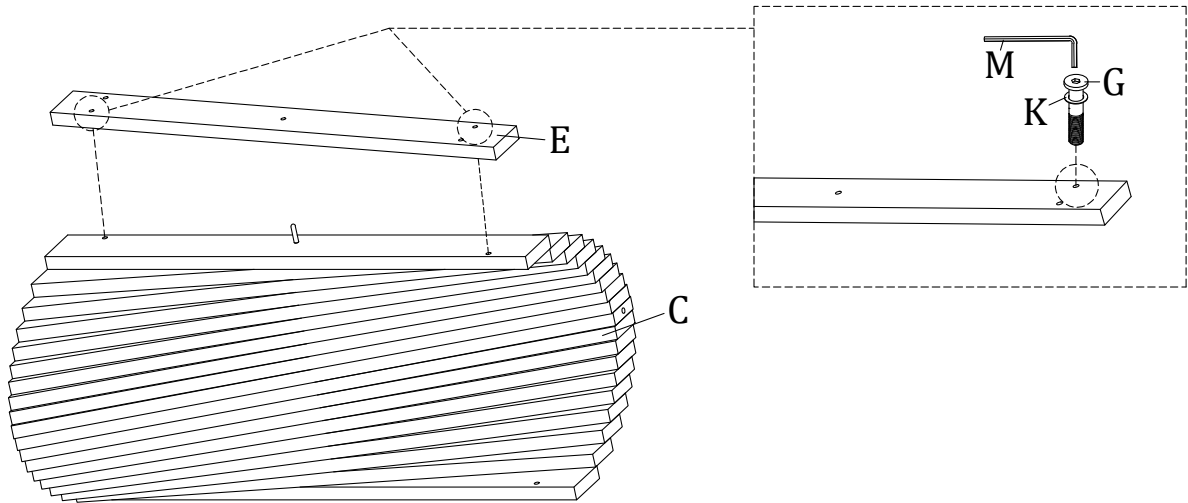

- 5** Insert Wood Dowel (F) into the Connector Support Leg (E).

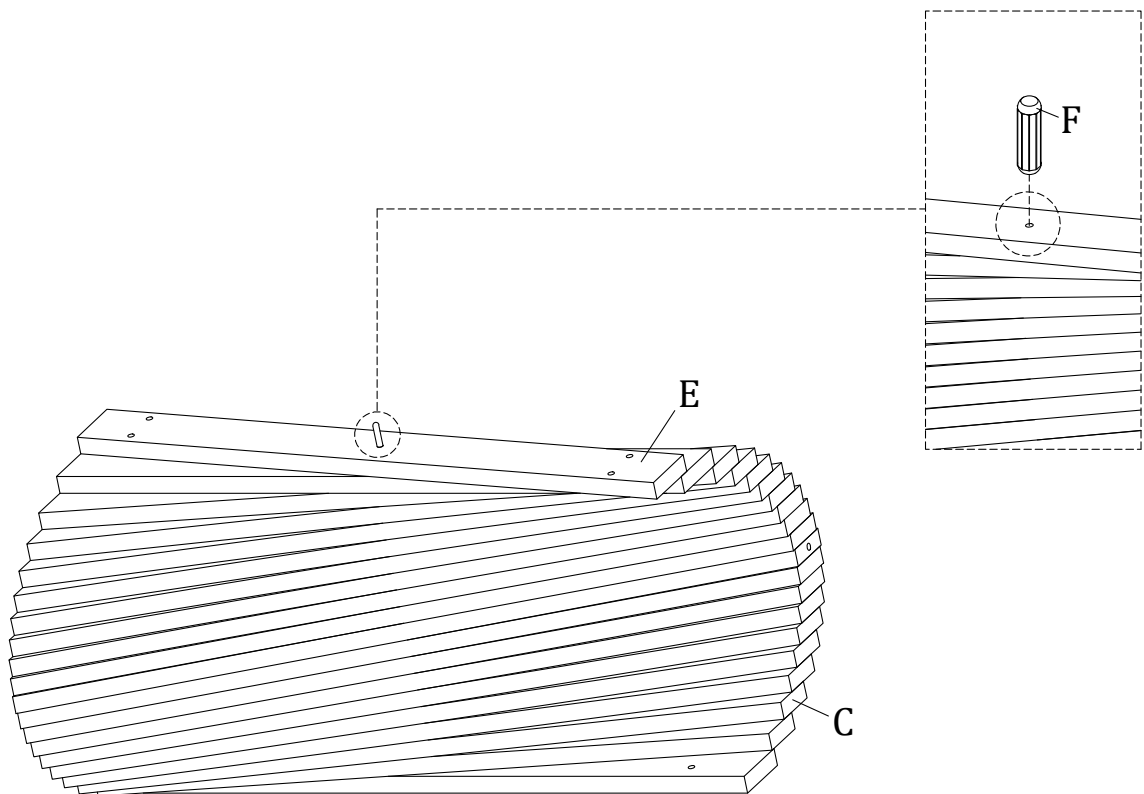

- 6** Attach the Leg (Big) (C) to the Connector Support Leg (E) by using JCBC Bolt (G) and Flat Washer (K) with the Allen Key (M).

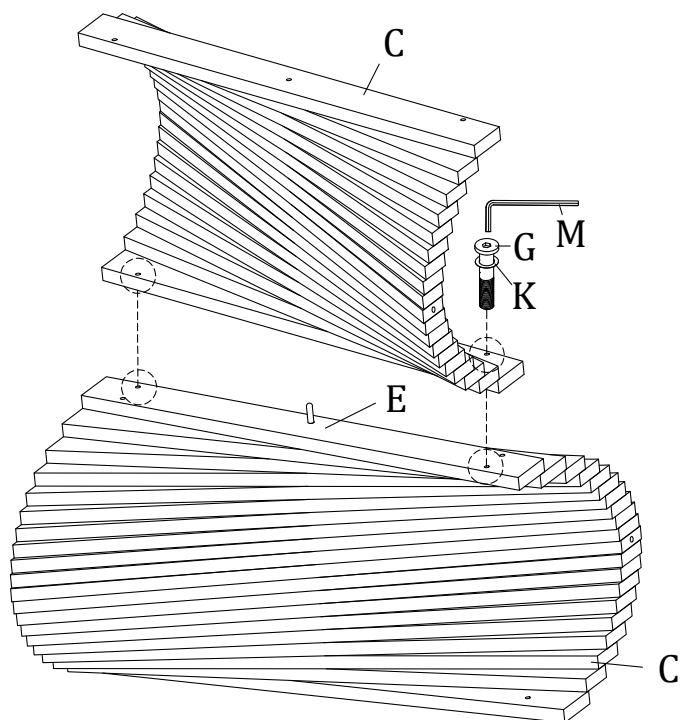

- 7** Insert Wood Dowel (F) into the Leg (Big) (C).
Tip : Stand the legs up to continue assembly.

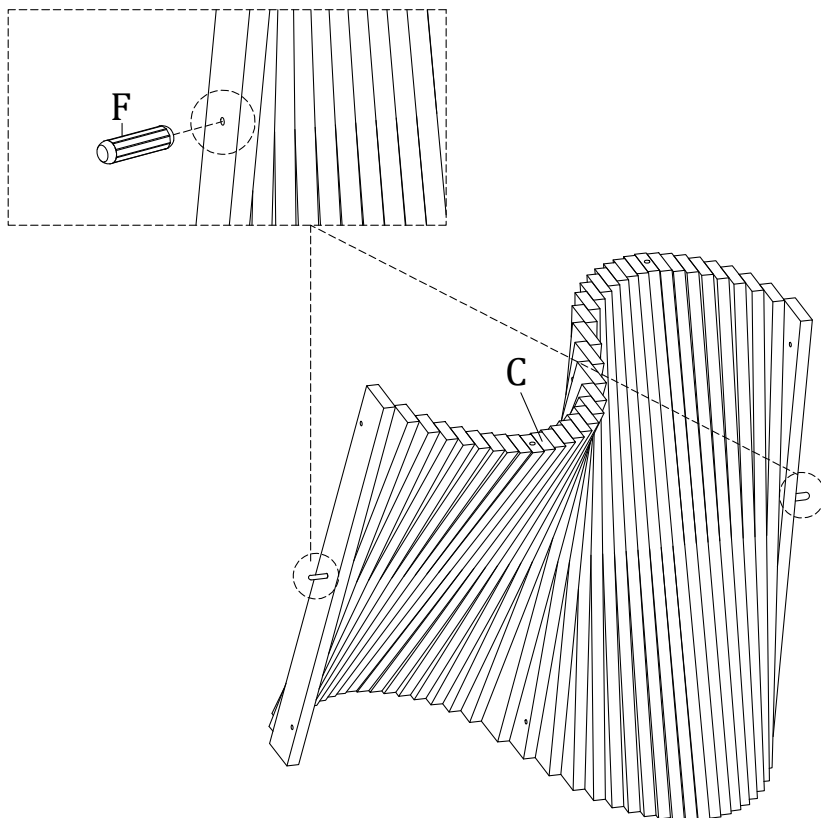

- 8** Attach the Connector Support Leg (E) to the Leg (Big) (C) by using JCBC Bolt (G) and Flat Washer (K) with the Allen Key (M).

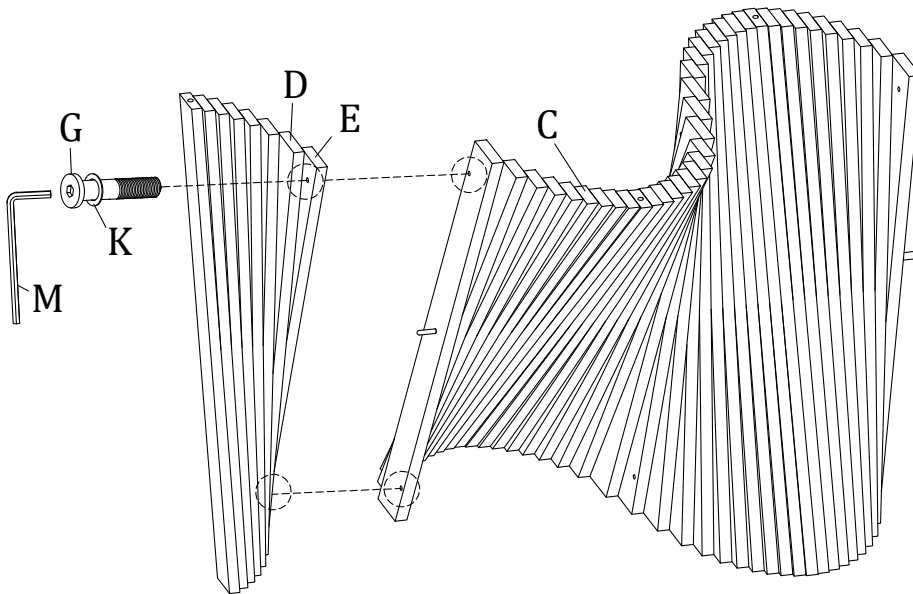

- 9** Attach the Connector Support Leg (E) to the Leg (Big) (C) by using JCBC Bolt (G) and Flat Washer (K) with the Allen Key (M).

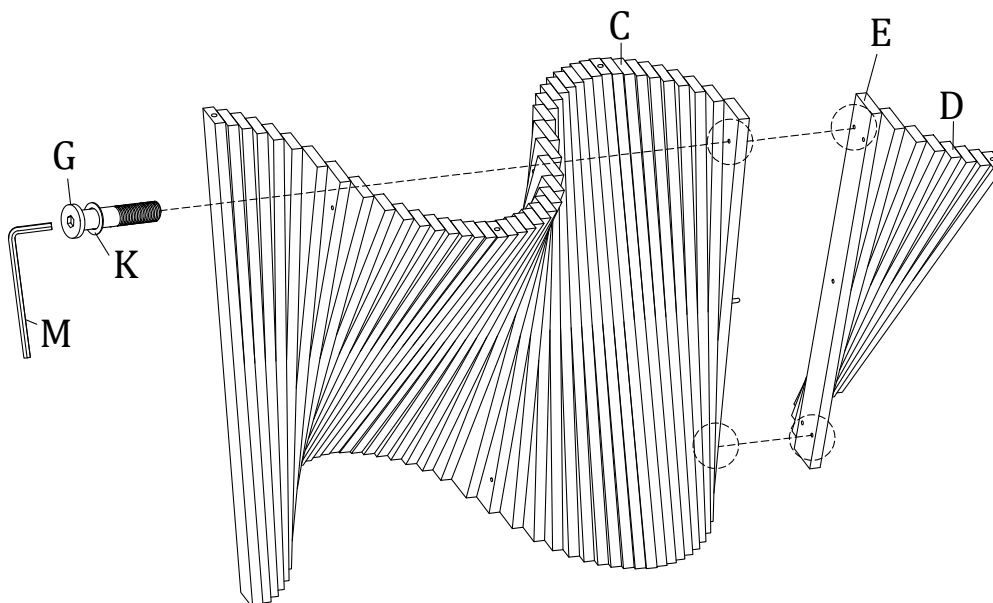

- 10** Attach the Frame (B) to the assembled legs by using JCBC Bolt (G), Spring Washer (I) and Flat Washer (J) with the Allen Key (M).

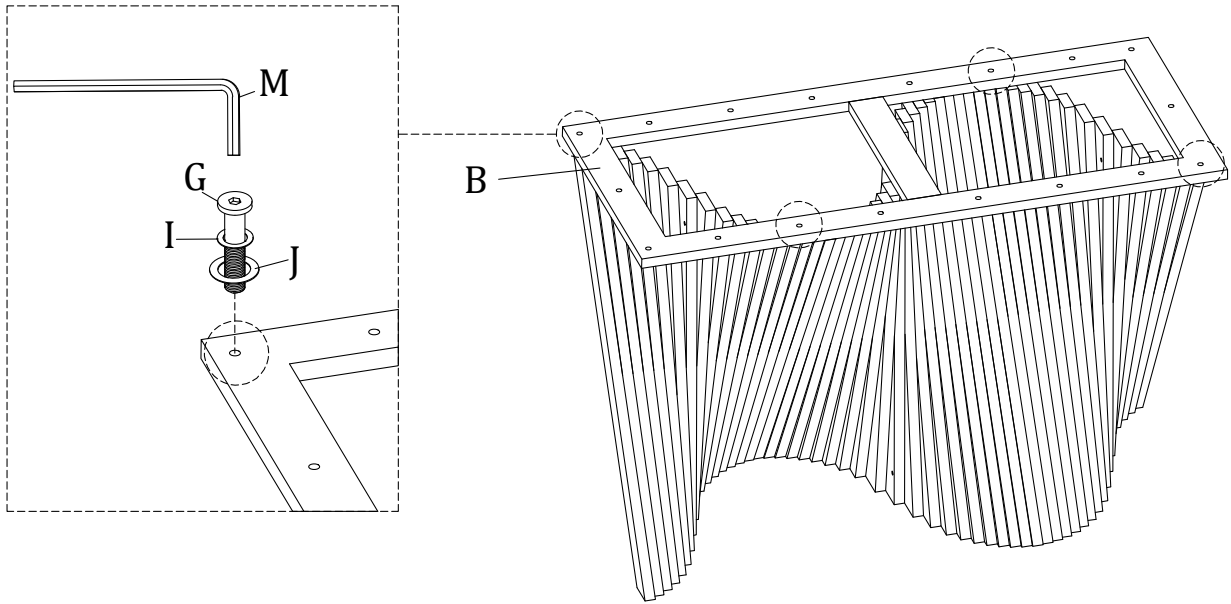

- 11** Attach the Table Top (A) to the Frame (B) by using JCBC Bolt (H) and Flat Washer (K) with the Allen Key (M).

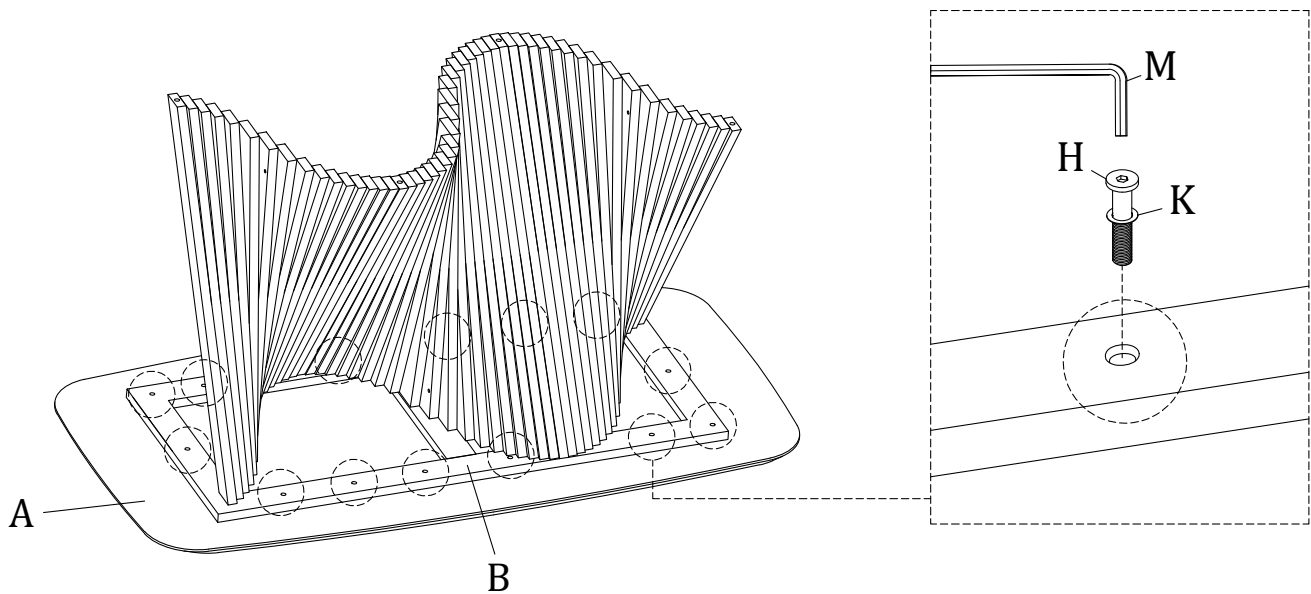

12 Attach Screw Adjuster (L) to the assembled legs.

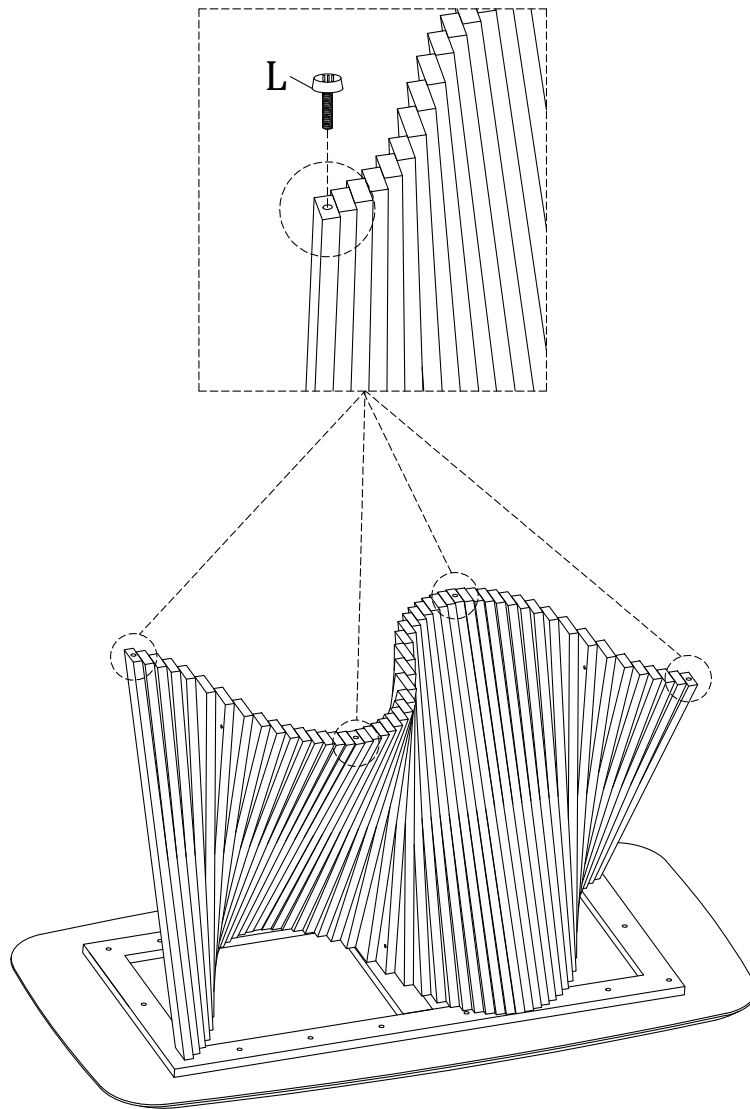

Cleaning & Care

Treat surfaces with care. Surfaces are resistant to scratches but are not scratch resistant. Clean surfaces with a dry or damp soft cloth. Do not use abrasive cleaners. Hardware may loosen over time. Periodically check that all connections are tight.

ASSEMBLY INSTRUCTIONS

DINING CHAIR

A Back Rest

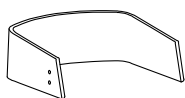

1 pc

B Seat Frame

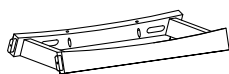

1 pc

C Cushion Seat



1 pc

D Leg

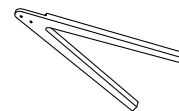

2 pcs

E JCBC Bolt
M6 x 70mm

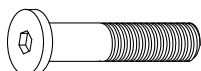

4 pcs

F JCBC Bolt
M6 x 35mm

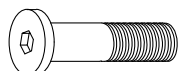

4 pcs

G JCBC Bolt
M6 x 25mm

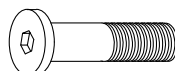

4 pcs

H Spring Washer
M6



12 pcs

I Allen Key
M4 x 100mm

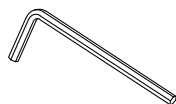

1 pc

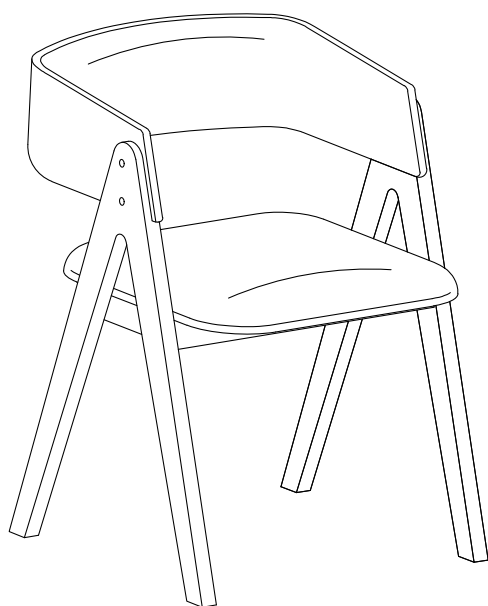

This page lists all the contents included in the box. Please take the time to identify the hardware as well as the individual components to this product. As you unpack and prepare for assembly, place the contents on a carpeted or padded area to protect them from damage.

- 1** Attach the Leg (D) to the Seat Frame (B) by using JCBC Bolt (E) and Spring Washer (H) with the Allen Key (I).

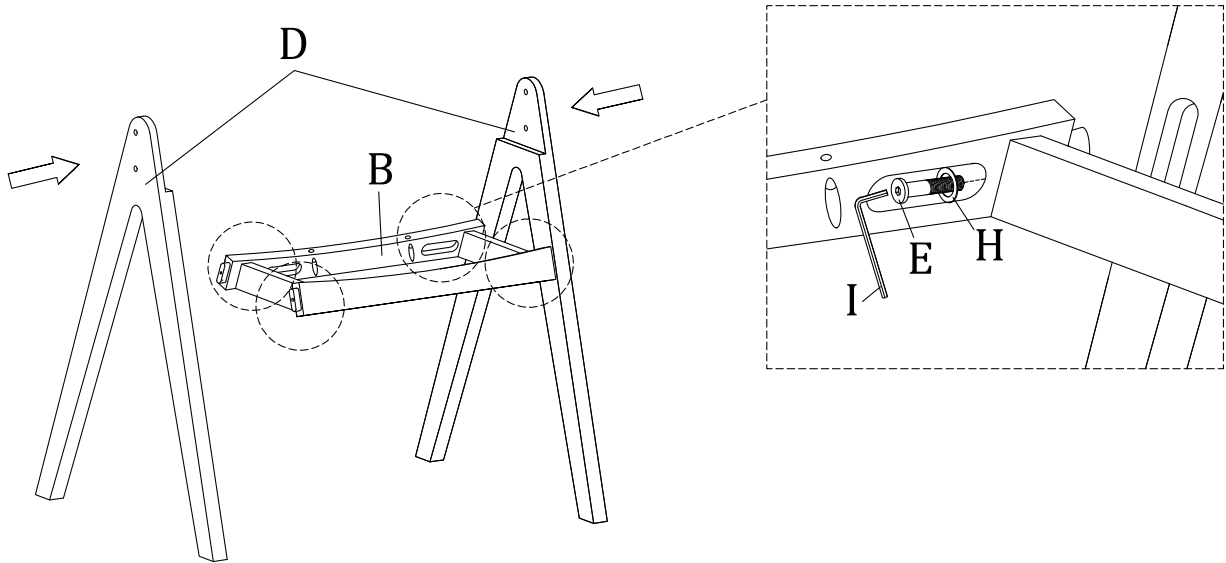

Take the Allen Key and turn the bolts until the legs are secured. **DO NOT TIGHTEN THE BOLTS COMPLETELY.** Stop when you feel you are adding force to tighten the bolts.

- 2** Attach the Cushion Seat (C) to the Seat Frame (B) by using JCBC Bolt (F) and Spring Washer (H) with the Allen Key (I).

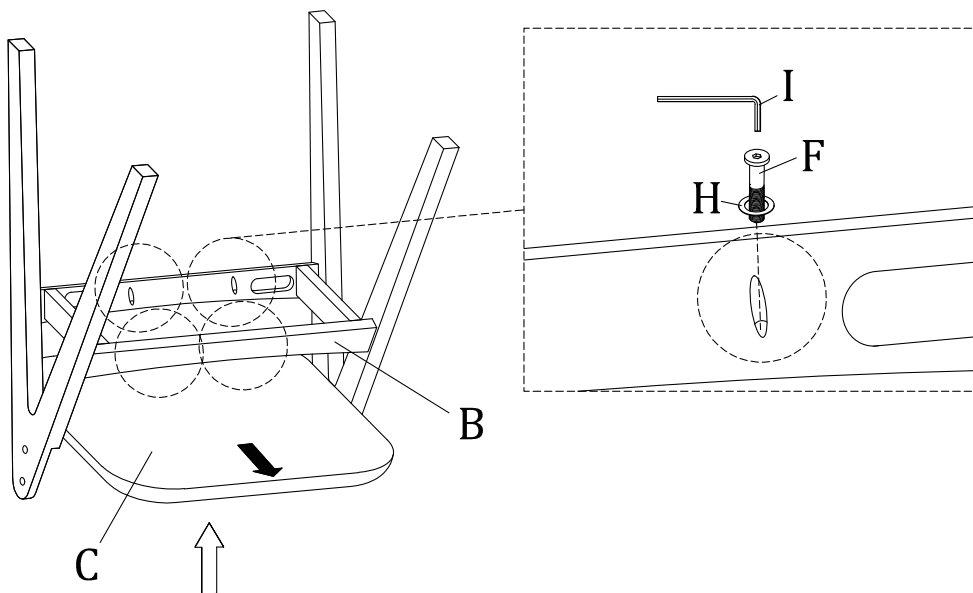

- 3** Attach the Back Rest (A) to the Leg (D) by using JCBC Bolt (G) and Spring Washer (H) with the Allen Key (I).

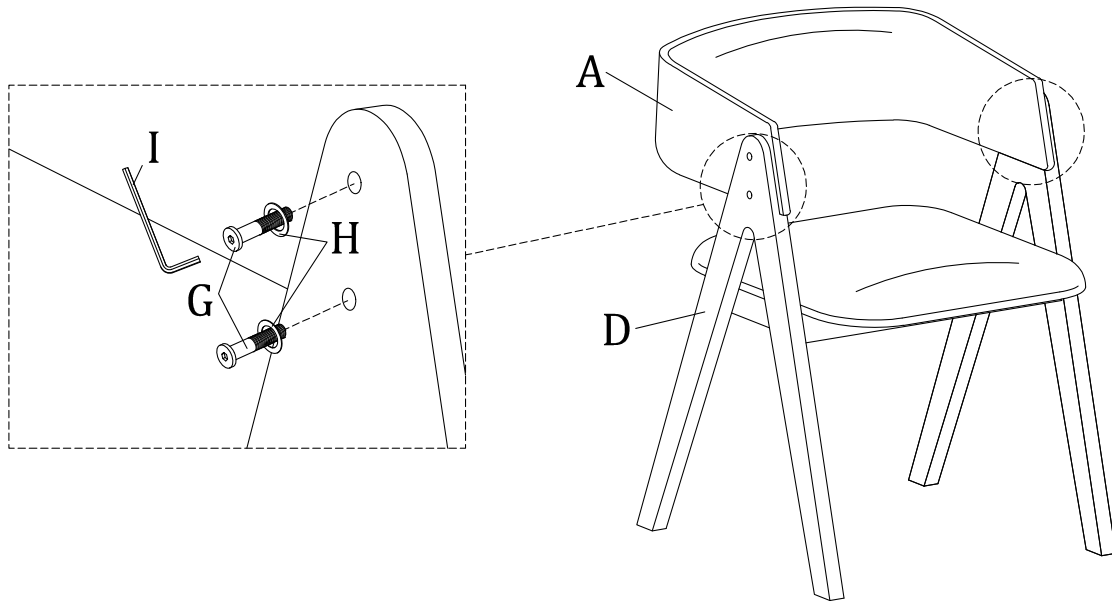

Stand the chair on an even surface and check for balance. If the chair wobbles slightly, apply downward pressure on the uneven leg and tighten the bolts to correct the imbalance. Once the chair is balanced, apply downward pressure evenly in the center of the chair and tighten all bolts, being careful not to over-tighten beyond the hole depth.

Helpful Tip : While tightening the bolts from underneath, have someone sit in the chair.

Cleaning & Care

Treat surfaces with care. Surfaces are resistant to scratches but are not scratch resistant. Clean surfaces with a dry or damp soft cloth. Do not use abrasive cleaners. Hardware may loosen over time. Periodically check that all connections are tight.