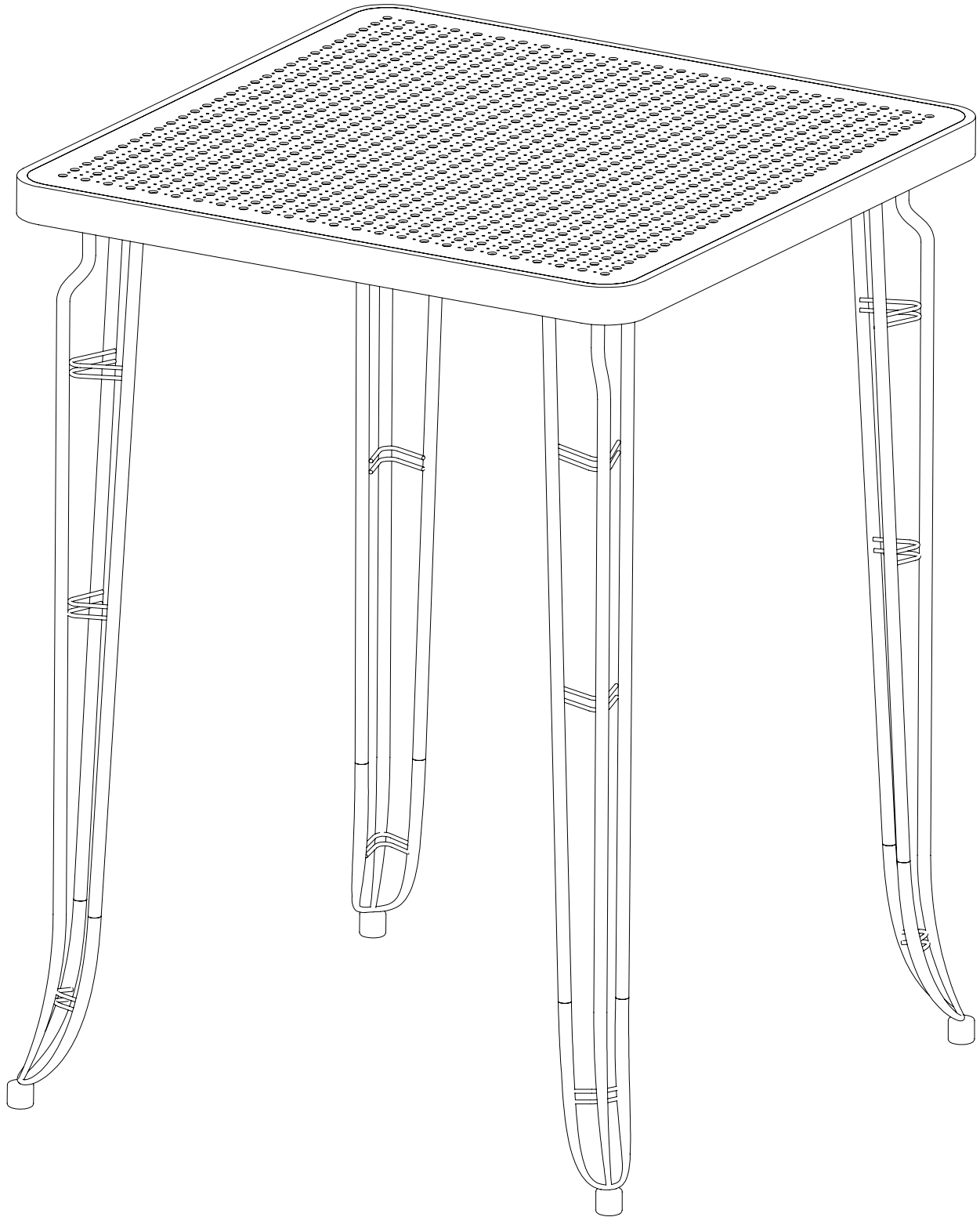

TABLE
ASSEMBLY INSTRUCTIONS





PLEASE READ ME FIRST



- Have questions about assembling your item?



- Item or parts damaged?



- Missing a part?



- We're here to help!

A

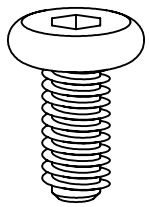

8 PCS

B



4 PCS

C

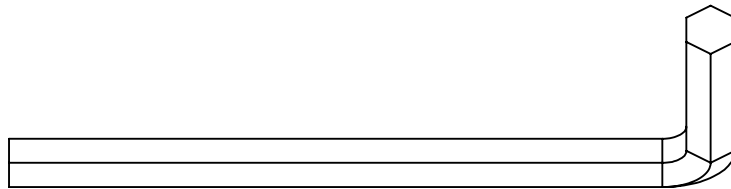

1 PC

1

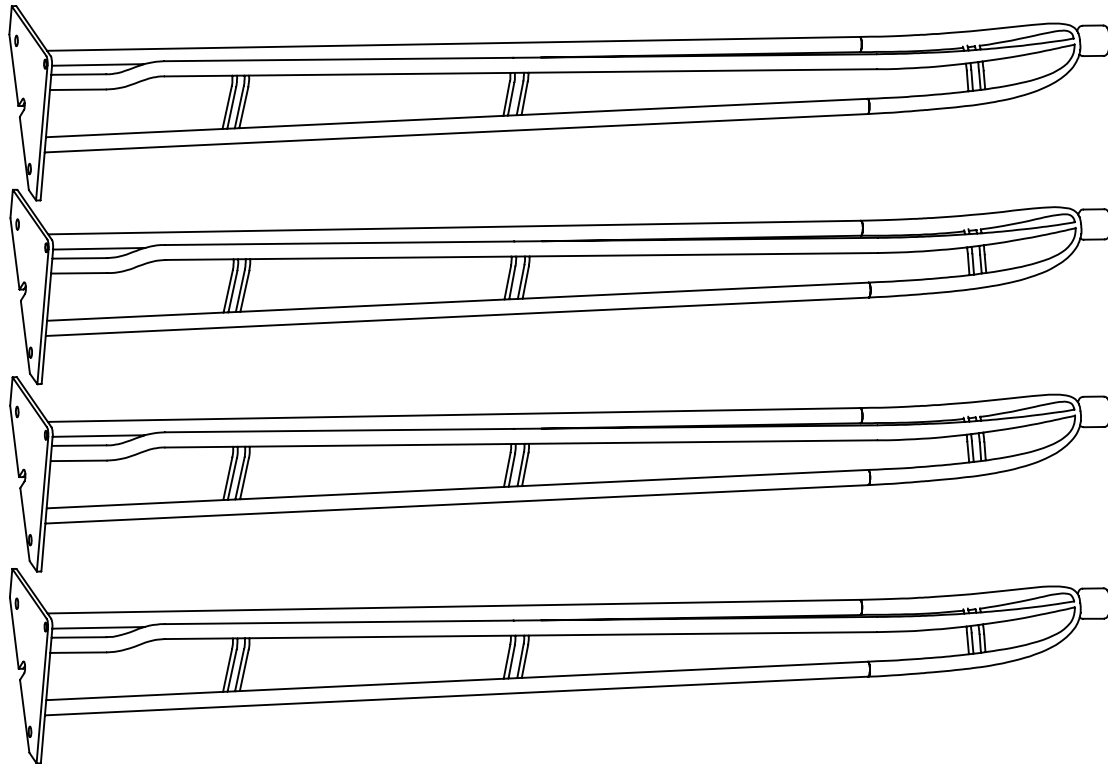

2

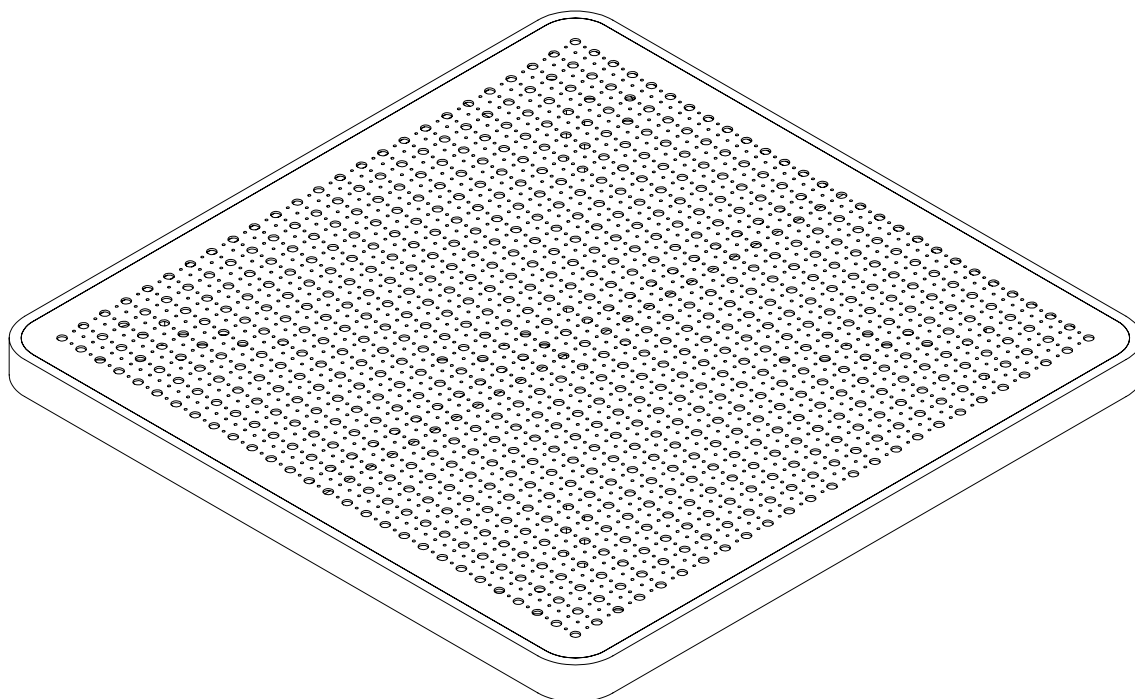

01

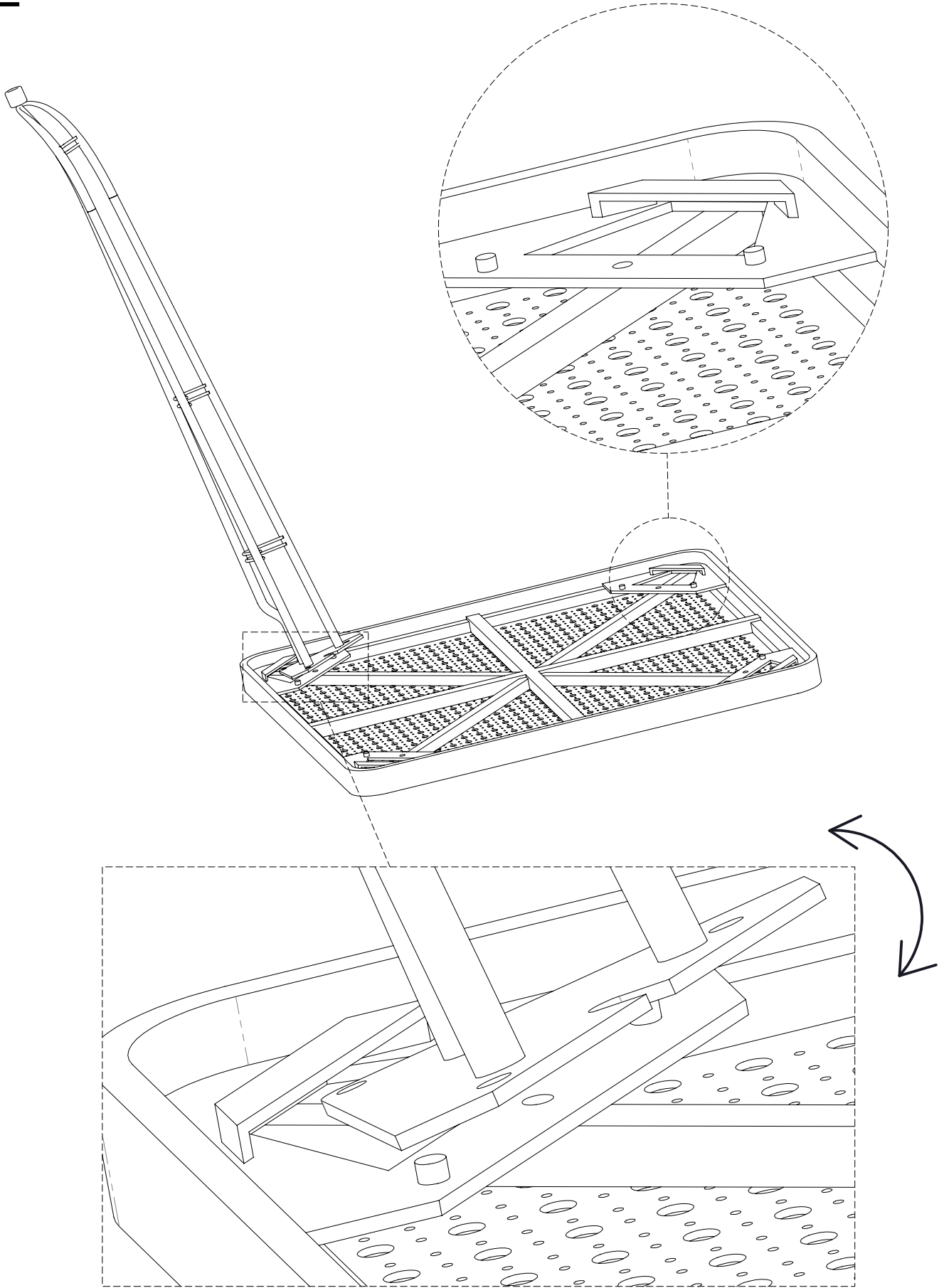

02

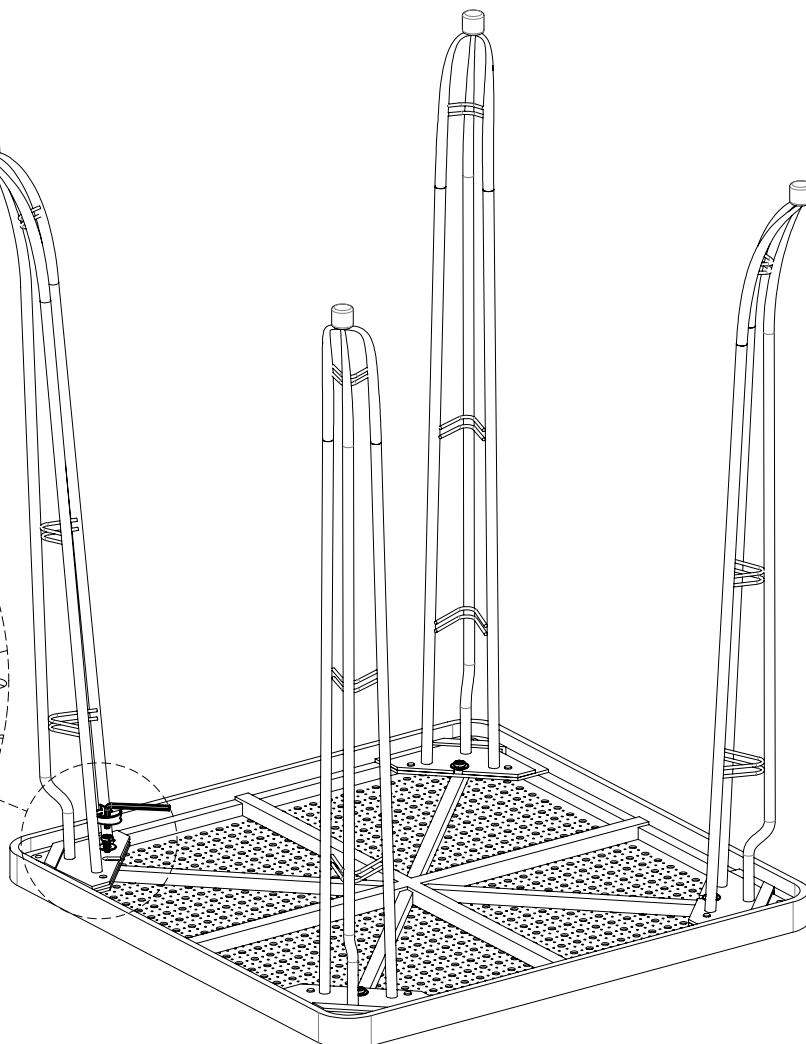
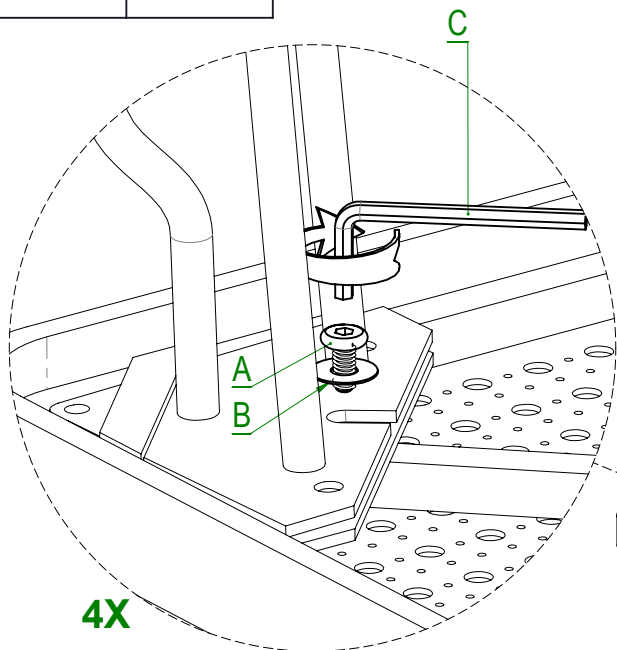
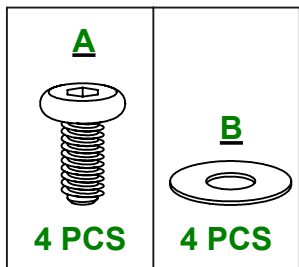

DO NOT TIGHTEN BOLT COMPLETELY.

03

TIGHTEN SCREW UNTIL IT CONTACTS THE TABLE TOP AND SECURES LEG IN BRACKET. STOP TIGHTENING SCREW WHEN GAP BETWEEN BRACKET AND LEG IS ELIMINATED.

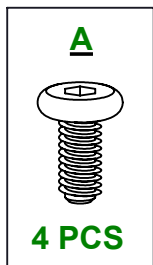

NO GAP

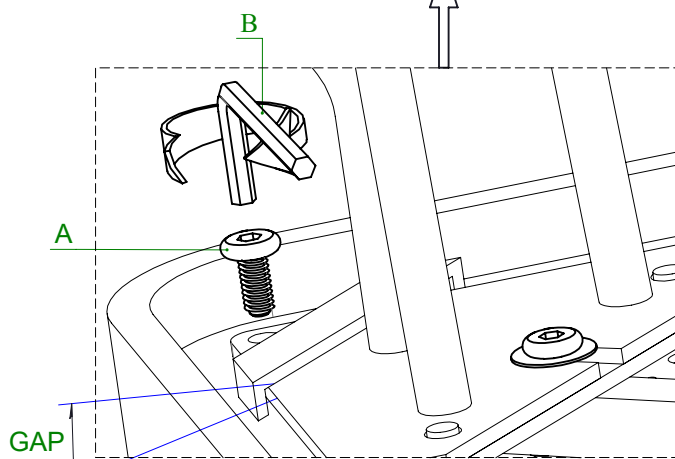
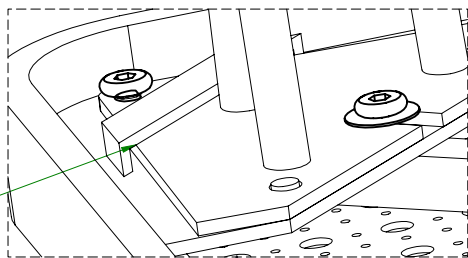

TIGHTEN BOLT COMPLETELY.
DO NOT OVERTIGHTEN.

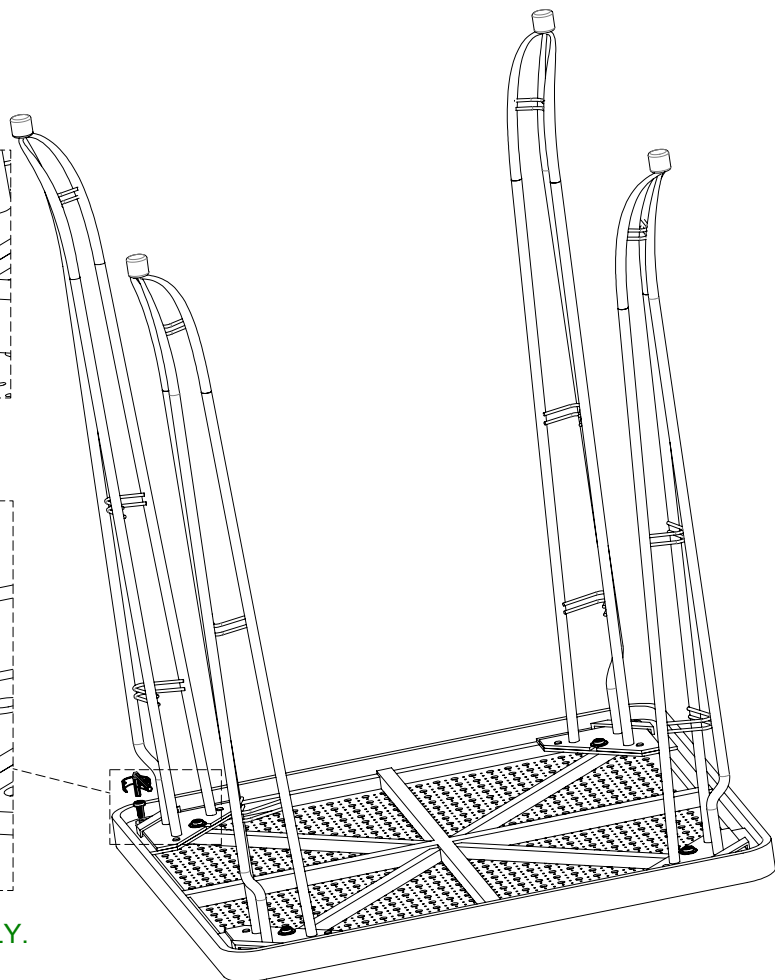

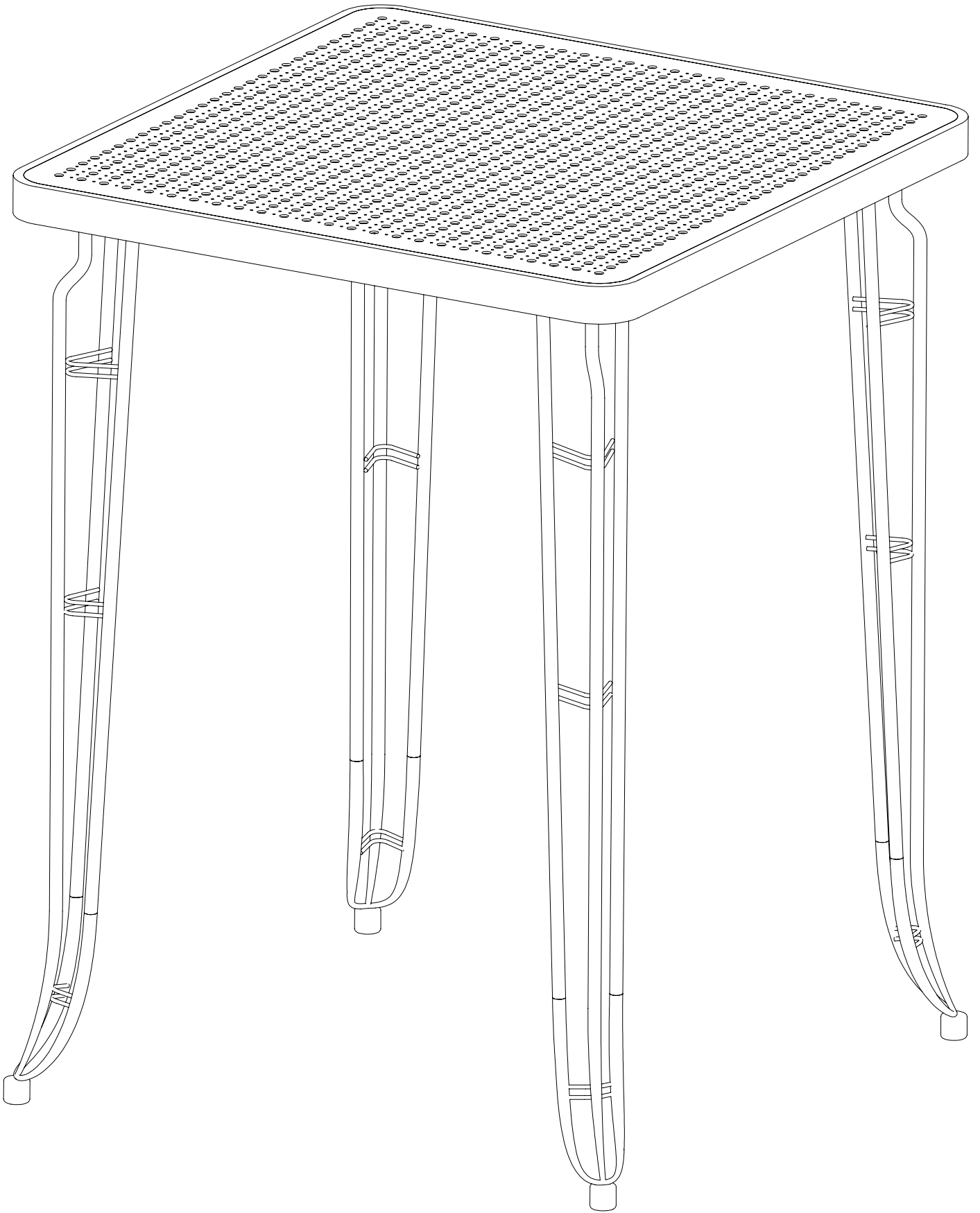

BE SURE TO CHECK ALL BOLTS ARE SECURELY
TIGHTENED PRIOR USING THIS TABLE.