

Assembly Instructions

Caution : You must read this before you proceed

BAR STOOL







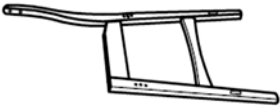

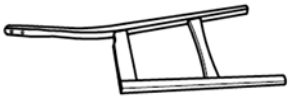
WARNING: These barstools are intended only for normal use with all four legs on the ground. These consumer barstools have relatively thin legs and are not designed to be sat in with only two legs on the ground (as from tipping back, forward, or to the side), and such can cause stress and failure of one or more barstool legs. Any misuse of the barstools voids any warranties, express or implied.







Part List

Label	Picture	Description	QTY
A		Side Frame (A)	1

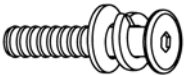
B		Side Frame (B)	1
---	--	----------------	---

C		Front Stretcher	1
D		Back Stretcher	1
E		Front Rail	1
F		Back Rail	1
G		Top Rest	1
H		Cushion Seat	1

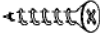
Hardware

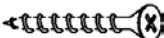
Label	Picture	Description	QTY
①		JCBC M6 x 25mm + S/W M6 + F/W M6 x 13mm	5
②		JCBC M6 x 45mm + S/W M6 + F/W M6 x 13mm	5
③		Allen Key M4	1
④		L Bracket	5
⑤		CSK Screw M3.5 x 12mm	9
⑥		Wood Dowel M8 x 25mm	3
⑦		FH Screw #8 x 32mm	5

⑧		Screwdriver	Not Provided
---	--	-------------	-----------------

Assembly Preparation

Before Beginning Assembly:

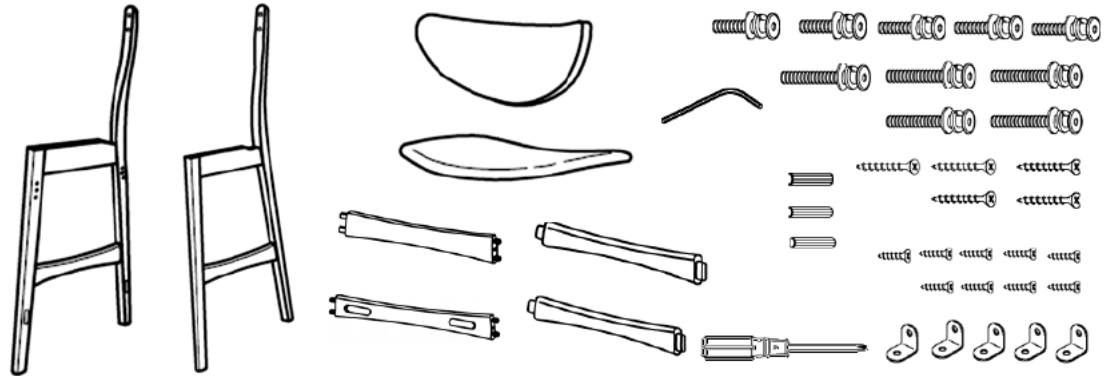

- Read instructions, cover to cover-



- Have 2 adults on hand for assembly-



- Do not assemble on flooring or carpet-



- Assemble on a clean non-marring surface (packing foam)-



- Save all packaging until finished-

Assembly Steps

Overview

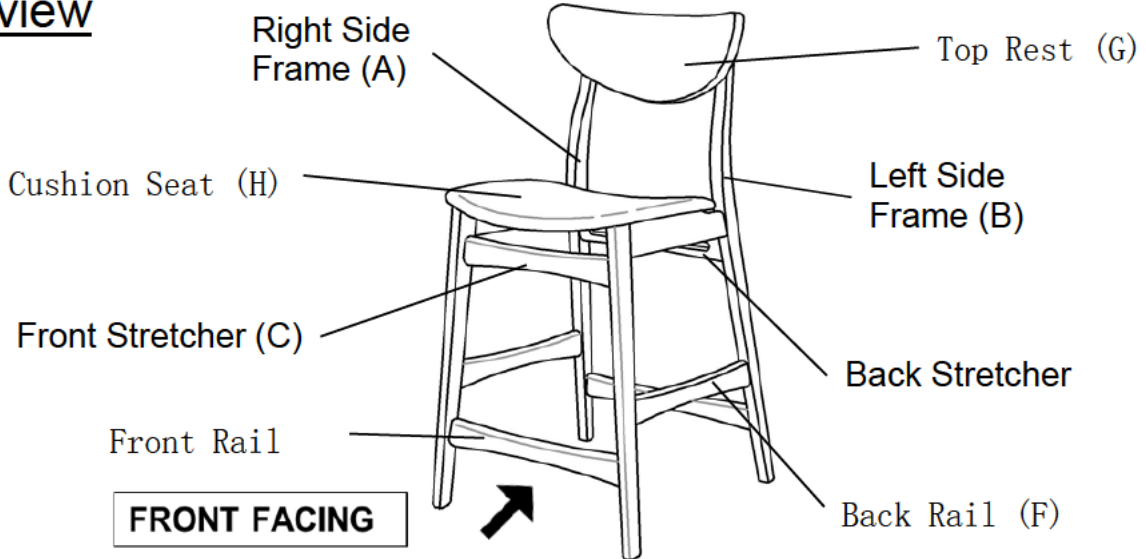

This Bar Stool has multiple parts and may require up to some 30 minutes to assemble. To give you an overview of the Bar Stool parts, the above picture is to help you put the various parts into perspective. Please read through the instructions below to familiarise yourself with the parts and steps before assembly.

Step 1

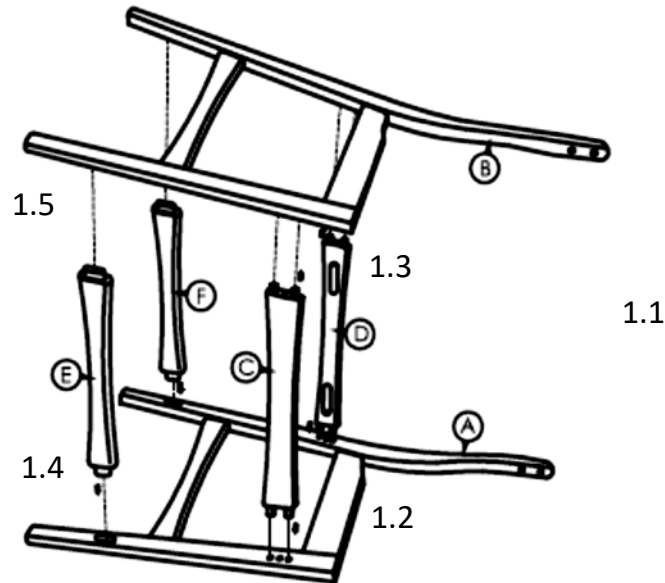

1.1 Place the Right Side Frame (A) and Left Side Frame (B) as shown.

1.2 Align the tenon of Front Stretcher (C) with the mount position of Side Frames.

1.3 Align the tenon of Back Stretcher (D) with the mount position of Side Frames.

1.4 Align the tenon of Front Rail (E) with the mount position of Side Frames.

1.5 Align the tenon of Back Rail (E) with the mount position of Side Frames.

Step 2

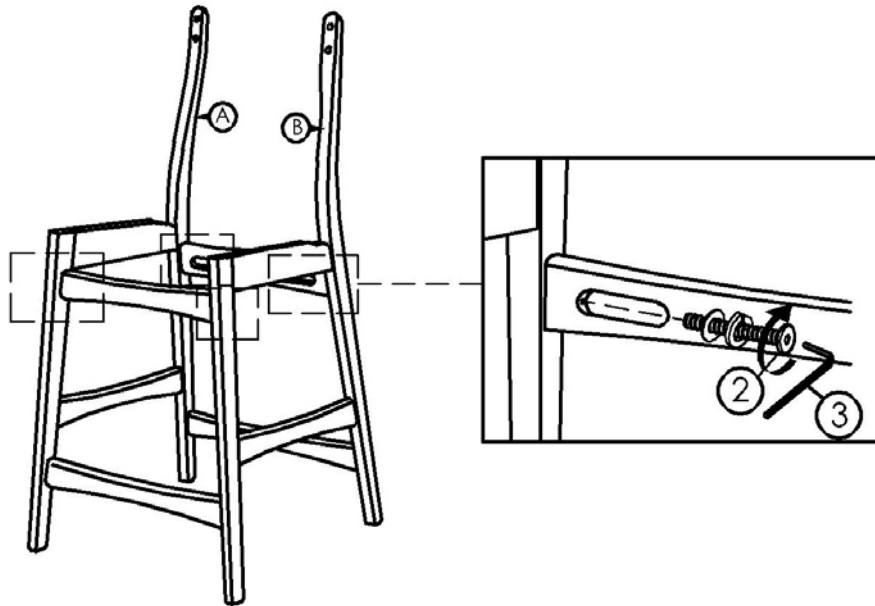

Then, fix the Front Sretcher (C) and Back Sretcher (D) with JCBC Bolt ② + Spring Washer + Flat Washer using Allen Key ③.
DO NOT FULLY TIGHTEN SCREWS.

Step 3

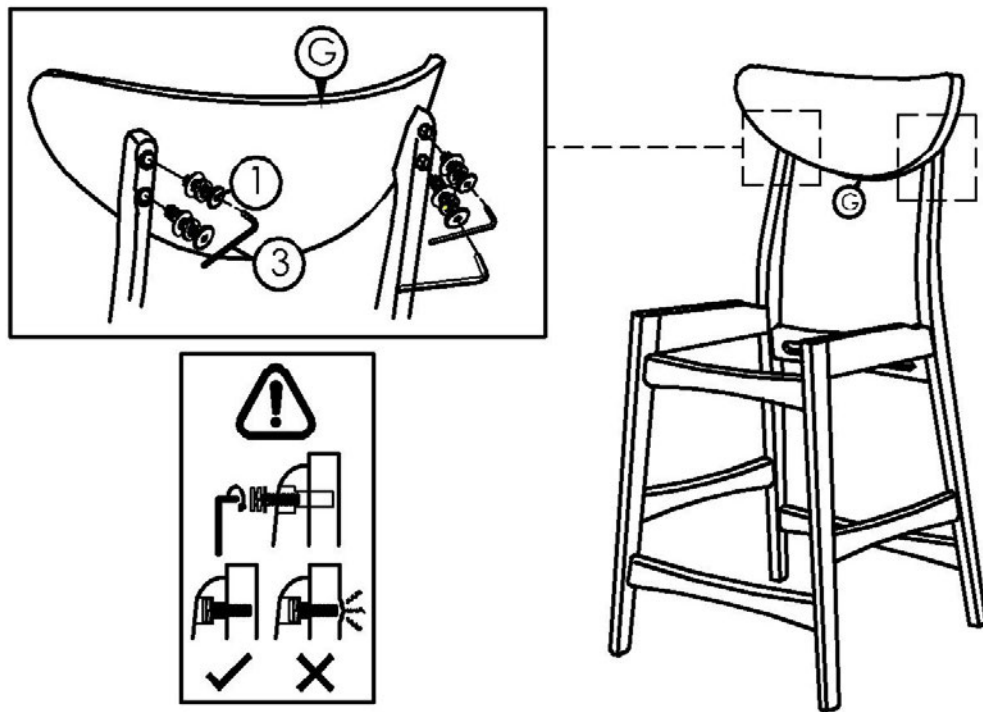

Place the Top Rest (G) on the back frame as shown above.
Then, fix the Top Rest (G) with JCBC Bolt ① + Spring Washer + Flat Washer using Allen Key ③.
DO NOT FULLY TIGHTEN SCREWS.

Step 4

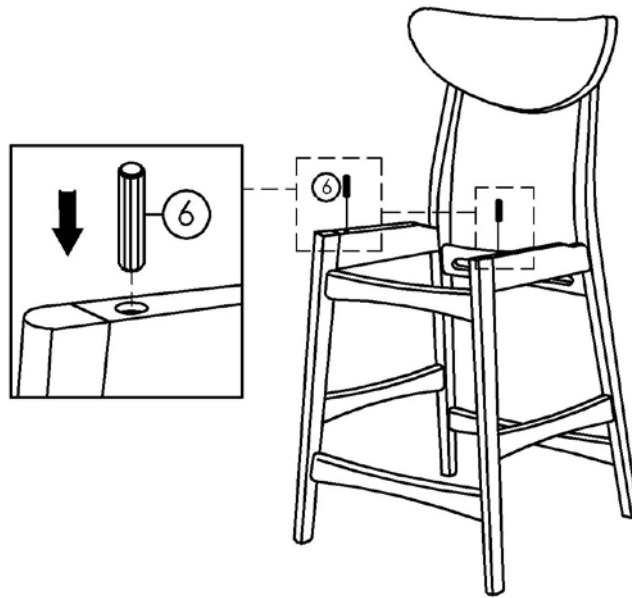

Place Wood Dowel ⑥ on the Side Frame as shown above.

Step 5

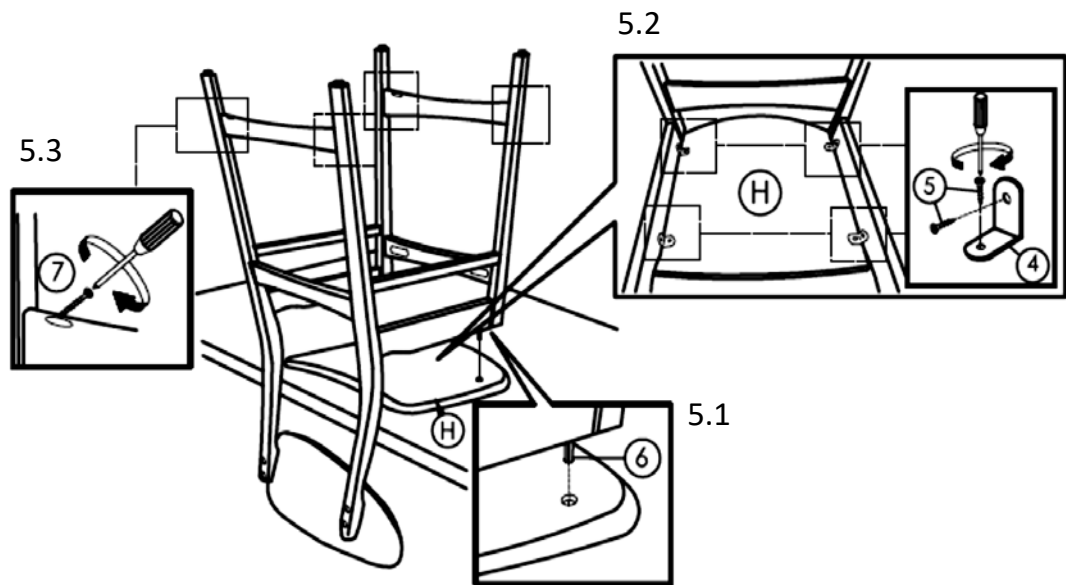

5.1 Place the Cushion Seat (H) on the table, then put the assembled chair parts in Step 4 to fix the Cushion Seat (H) as shown.

Align the the Wood Dowel ⑥ into the tenon of Cushion Seat (H) as shown above.

5.2 Then, fix the Cushion Seat (H) with L-Bracket ④ and Screws ⑤ using Screwdriver not provided.

5.3 Fix the Front Rail (E) And Back Rail (F) with Screw ⑦ using Screwdriver (not provided).

DO NOT FULLY TIGHTEN ALL THE BOLT AND SCREWS NOW.

Step 6



Turn clockwise or anti-clockwise to adjust leg leveller.

Turn clockwise or anti-clockwise to adjust leg leveller. The **Max** height during 0.25~0.8inch.

Step 7

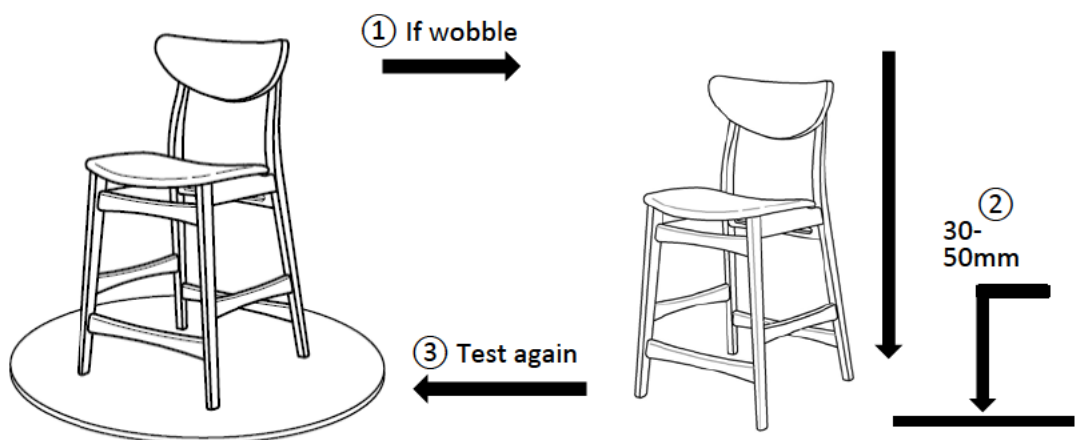

Place the bar stool on a Level Surface to check if it wobbles.

If it wobbles, lift the bar stool some 30mm to 50mm high from the ground, keep your feet and toes well away from the drop zone, and drop the bar stool freely and vertically with the four legs, hitting the ground at the same time.

This Drop Test will help to ensure that all the bolts and gaps to all reach full alignment.

Test again for evenness on Level Surface.

If no wobbles are found, proceed to tighten all the Bolts.

Caution: When tightening the Bolts, tighten sequentially.

Do not tighten any screw fully and then towards the next one, this would cause the frame to warp. If it still wobbles, loosen the bolts and execute this same drop test.

If the bar stool is not Stable it could lead to damage to the product.

Step 8



Inspect and make sure all parts are connected.

The bar stool is ready for use.

Caution: This bar stool can only be used on a flat, level surface.

Care & Maintenance



- Furniture may scratch floors. We recommend using furniture pads to protect your floors.



- Do not put hot items directly on furniture surface.



- Do not clean furniture with harsh cleansers or polish.



- Do not place furniture under direct sunlight.



- Do not place furniture near heating or cooling vents.



- Do not write on furniture without a padded barrier to protect the surface.



- Do not place furniture outside . For indoor use only.



- Not for commercial use. For residential use only.



- Stains may be removed with mild soap solution and damp cloth.



- Children should not climb or jump on the furniture.



- Dust and pick-up spills using a clean, non-colored, lint-free cloth.