

# ASSEMBLY INSTRUCTIONS

Toll - Free Number : 1-833-273-2277

MODEL : BQ0105-1 / BQ0105-2

## QUEEN BED

(Box 1)

### BOX OF HEADBOARD & FOOT

No	ITEM	Qty
A	Headboard	1 pc
B	Footboard	1 pc
C	Headboard Leg (L/R)	2 pcs
D	Bed Slats	4 pcs
E	Bed Slats Support	4 pcs

(Box 2)

### BOX OF SIDERAIL

No	ITEM	Qty
F	Side Rail	2 pcs

(Box 1)

### HARDWARE LIST

No	ITEM	Qty
1	CSK M4 x 32mm	8 pcs
2	JCBC M6 x 30mm	6 pcs
3	SPRING WASHER 1/4" Blk	6 pcs
4	Flat Washer 1/4" x 13mm OD Blk	6 pcs
5	ALLEN KEY M4 x 65mm Blk	1 pc
6	ALLEN KEY M5 x 65mm Blk	1 pc

STEP 1 : Attach Headboard Leg ( C ) to Headboard ( A ) as shown using JCBC Bolt ( 2 ) with Spring Washer ( 3 ), Flat washer ( 4 ) and securing with Allen Key ( 5 ).

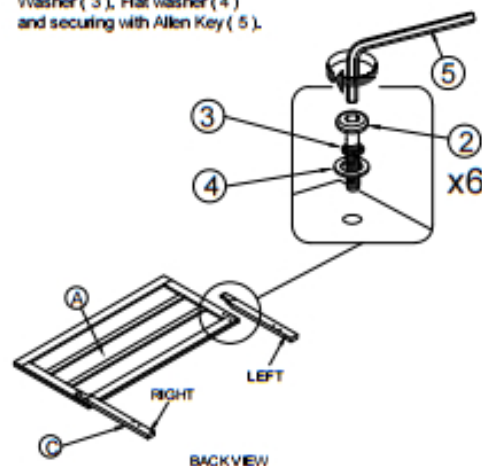

STEP 2 : Hook Side Rail ( F ) to Headboard ( A ) closely and push down to fit, repeat step 3 with other end of rail to hook onto Footboard ( B ).

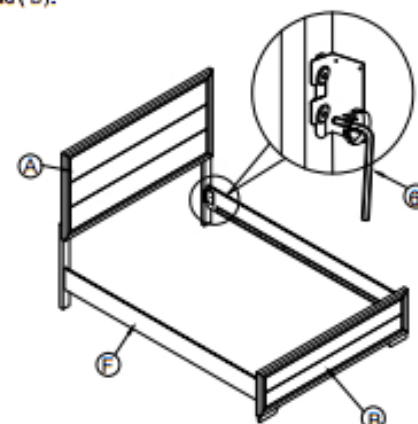

STEP 3 : Tighten the 4 Corner with Allen Key ( 6 ). Fix the Bed Slat Support Leg ( E ), to Bed Slat ( D ) as shown. Install the bed slat ( D ) to siderail ( F ) and tighten with CSK Screw ( 1 ) as per diagram shown. (NOTE: THE SETUP MUST BE DONE AT THE DECIDED LOCATION FOR THE BED TO OBTAIN PERFECT STABILITY)

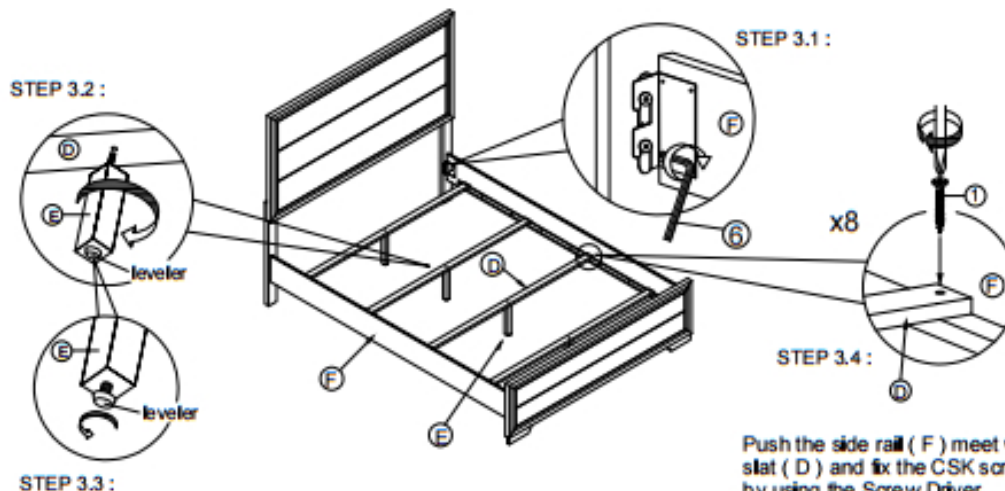

**COMPLETED ASSEMBLY**

Push the side rail ( F ) meet with wooden slat ( D ) and fix the CSK screw ( 1 ) by using the Screw Driver.

NOTE : MUST TIGHTEN SCREWS PERIODICALLY WITH USE SCREW WILL BECOME LOOSE CHECK TIGHTNESS OF ALL SCREW EVERY 6-8 WEEKS.