

MONTAJE - MONTATGE - GEBRAUCHSANWEISUNG - ASSEMBLING - MONTAGE

**1** ENSAMBLAR EL ZÓCALO METÁLICO  
ASSEMBLING THE METAL FRAME

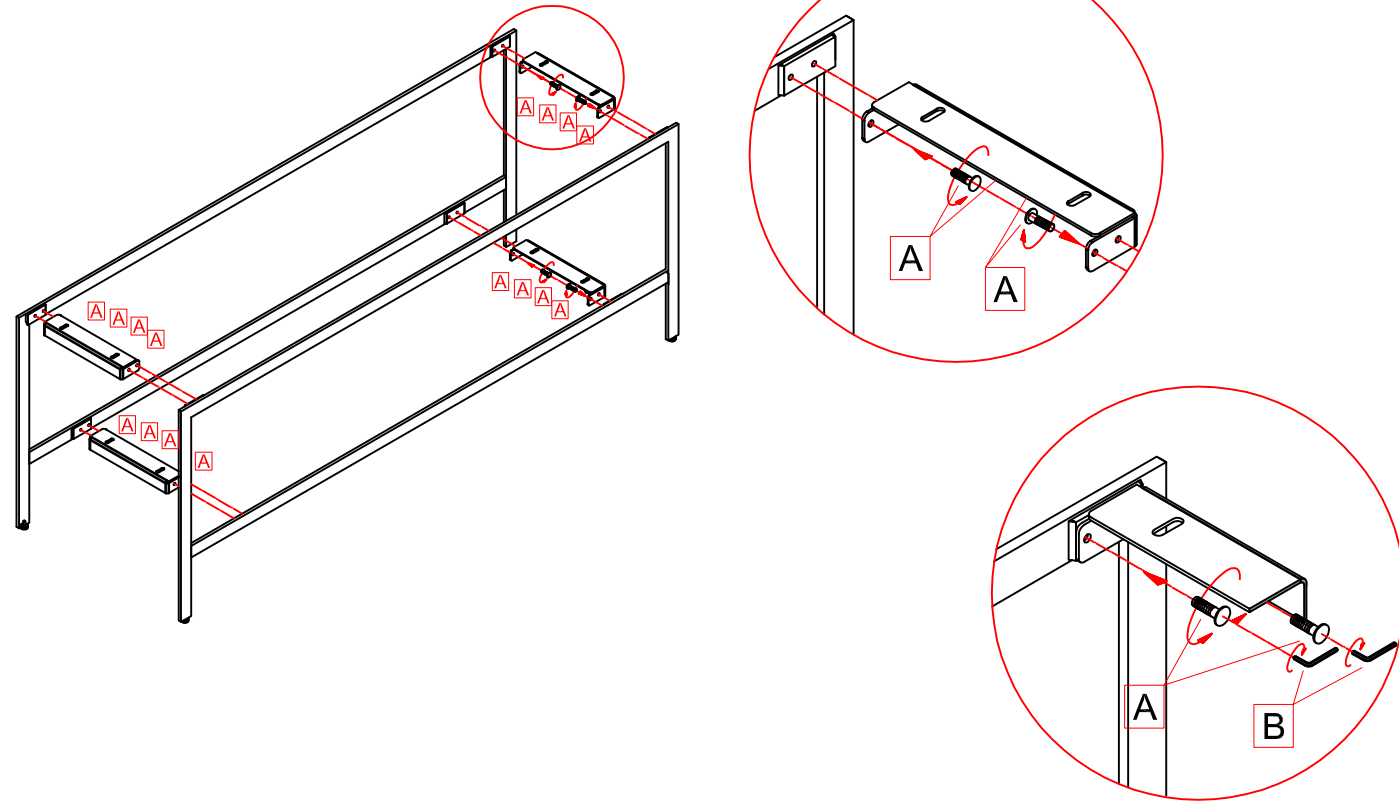

**2** COGER EL MÓDULO CON CUIDADO POR AMBOS LADOS  
TAKE THE MODULE CAREFULLY FROM BOTH SIDES

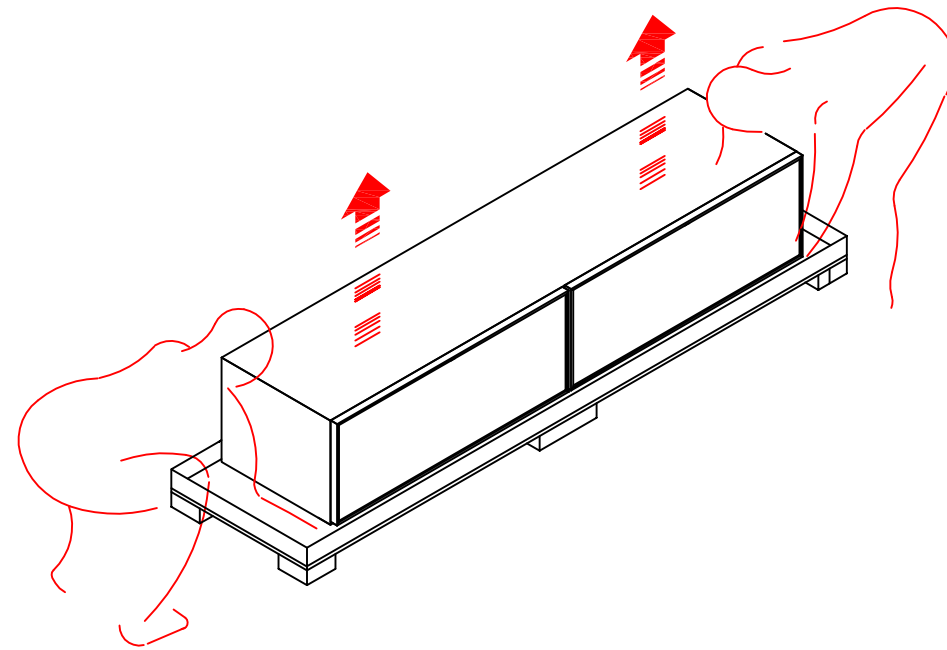

**3**  CUIDADO CON NO ROZAR LOS COSTADOS AL COLOCAR EL MÓDULO  
BE CAREFUL NOT TO RUB THE SIDE PANELS WHILE INTRODUCING THE MODULE

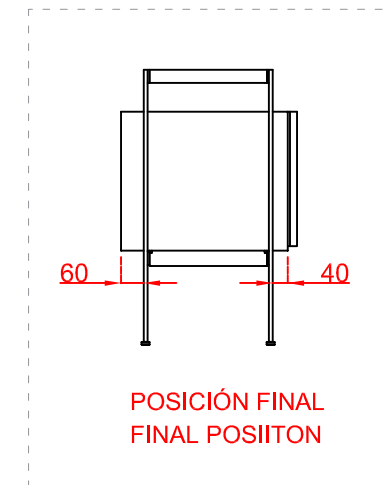
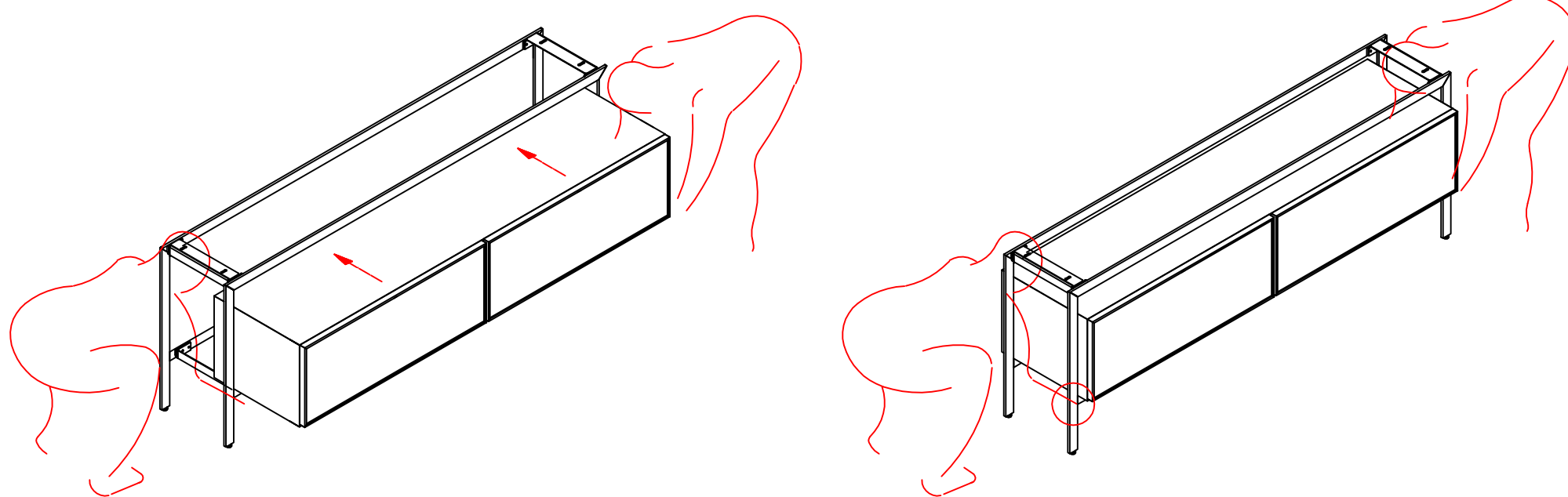

HERRAJE - FERRATJE - FITTINGS - EISENBESCHLAG - QUINCALLERIE - FERRAMENTA - HERRAJE - FERRATJE - FITTINGS - EISENBESCHLAG - QUINCALLERIE - FERRAMENTA - HERRAJE - FERRATJE - FITTINGS - EISENBESCHLAG

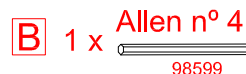
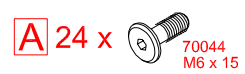

MONTAJE - MONTATGE - GEBRAUCHSANWEISUNG - ASSEMBLING - MONTAGE

**4** FIJAR BASE DEL MÓDULO AL ZÓCALO  
FIX THE MODULE BASE TO THE METAL FRAME

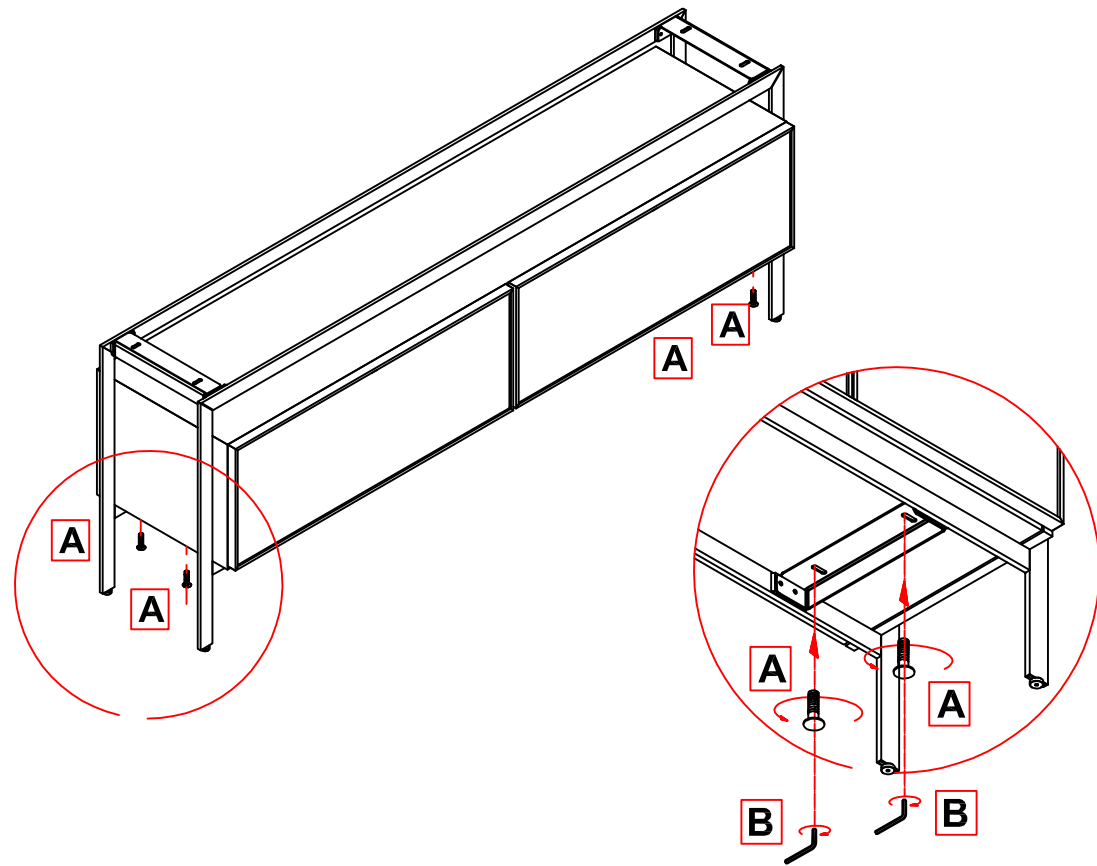

**5** ABRIR PUERTAS Y FIJAR MÓDULO AL ZÓCALO  
OPEN THE DOORS & FIX THE MODULE TO THE METAL FRAME

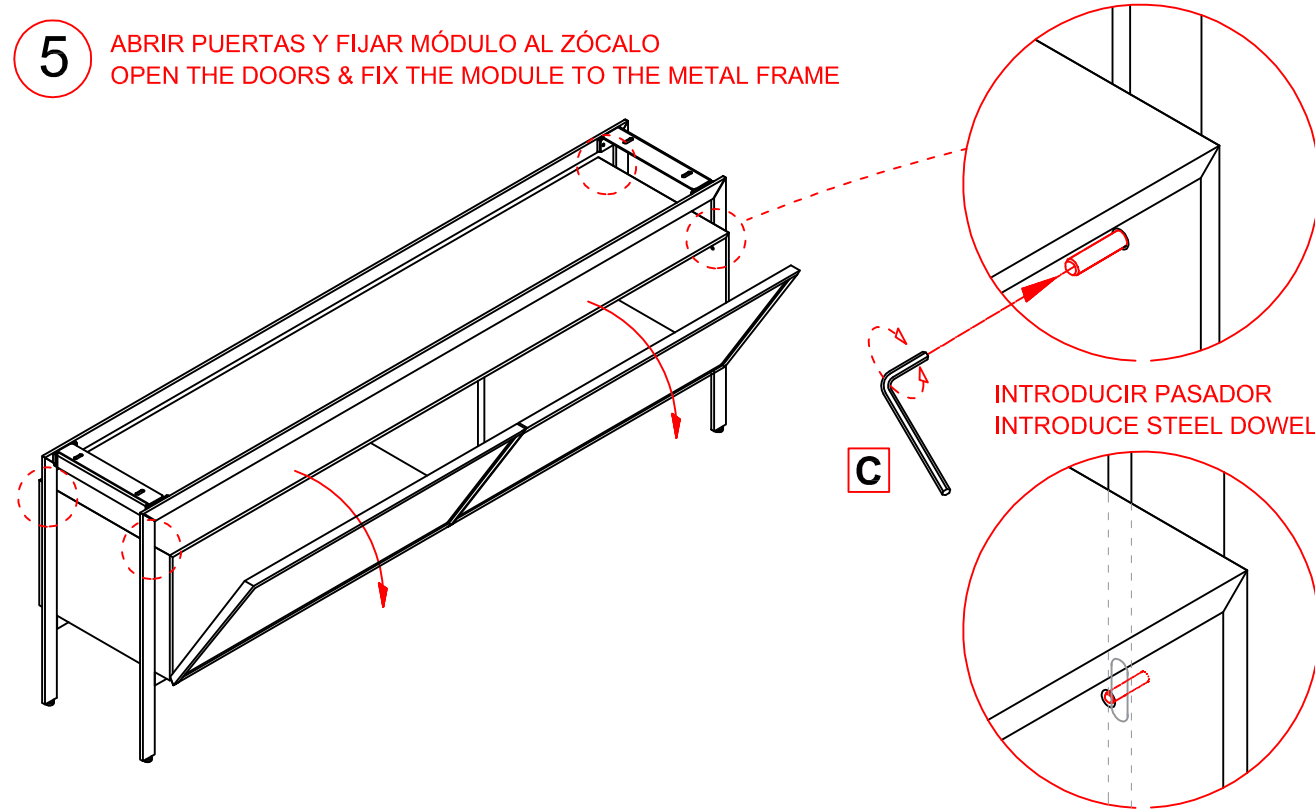

**6** REGULACIÓN  
REGULATION

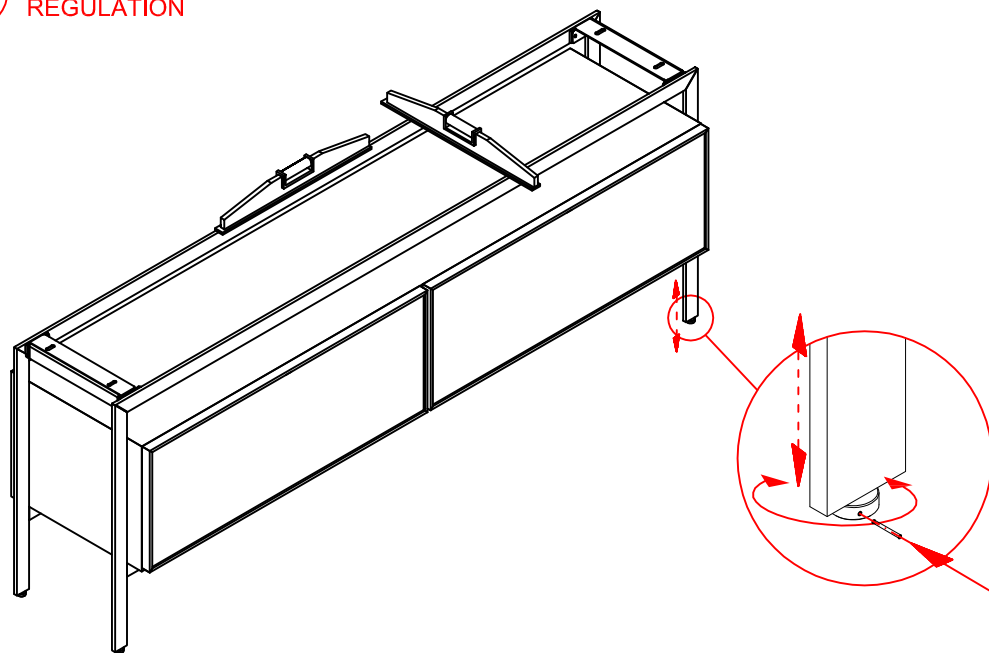

**ATENCIÓN: VER HOJA DE MANIPULACIÓN DEL SOBRE DE MÁRMOL**  
**WARNING: SEE THE MARBLE TOP HANDLING SHEET**

HERRAJE - FERRATJE - FITTINGS - EISENBESCHLAG - QUINCALLERIE - FERRAMENTA - HERRAJE - FERRATJE - FITTINGS - EISENBESCHLAG - QUINCALLERIE - FERRAMENTA - HERRAJE - FERRATJE - FITTINGS - EISENBESCHLAG

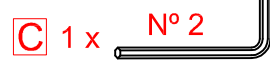
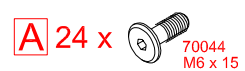

MONTAJE - MONTATGE - GEBRAUCHSANWEISUNG - ASSEMBLING - MONTAGE

**1** COMPROBAR CANTO Y CARA TRASERA DEL MARMOL  
CHECK EDGE AND BACK SIDE OF THE STONE

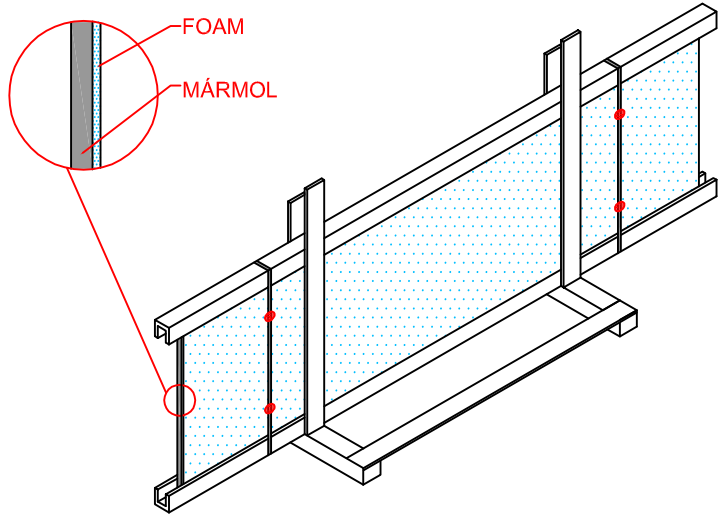

**2** AFLOJAR LAS PATAS ESTRUCTURALES Y QUITARLAS  
LOOSEN STRUCTURAL LEGS AND REMOVE THEM

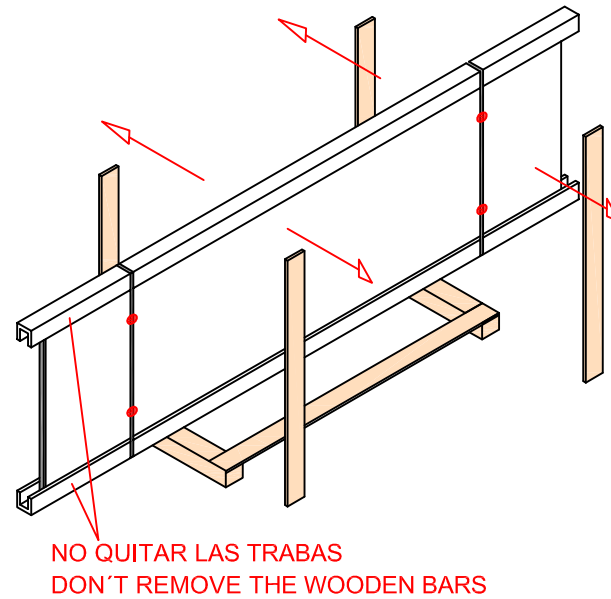

**3** EXTRAER EL SOBRE DE MÁRMOL CON LAS TRABAS (MIN. 2 PERS.)  
REMOVE THE MARBLE TOP WITH ITS WOODEN BARS (MIN. 2 PEOPLE)

**! ATENCIÓN: MANIPULAR MARMOL DE CANTO  
WARNING: HANDING THE MARBLE ON EDGE**

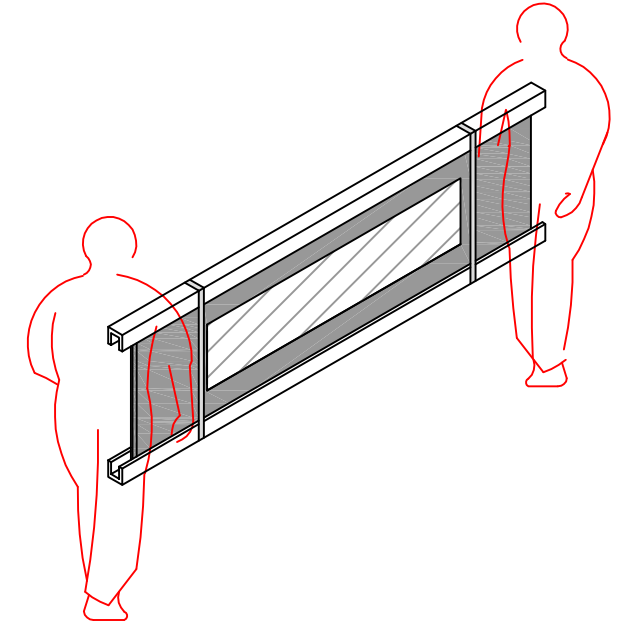

**4** APOYAR EL SOBRE EN EL ZÓCALO Y DESLIZAR  
SUPPORT THE TOP ON THE METAL FRAME AND SLIDE

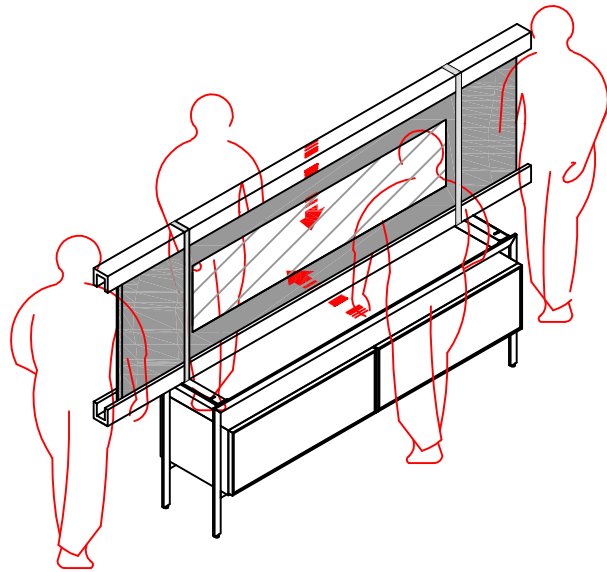

**! ATENCIÓN: MANIPULAR MARMOL DE CANTO  
WARNING: HANDING THE MARBLE ON EDGE**

**4 PERSONAS (NO RECOMENDABLE MENOS DE 3)  
4 PEOPLE (NOT RECOMMENDED LESS THAN 3)**

**5** GIRAR EL SOBRE Y ENCAJAR SUPLEMENTO DM DE LA ENCIMERA ENTRE EL ZÓCALO  
ROTATE THE TOP AND FIT THE MDF INFERIOR BOARD BETWEEN THE METAL FRAME

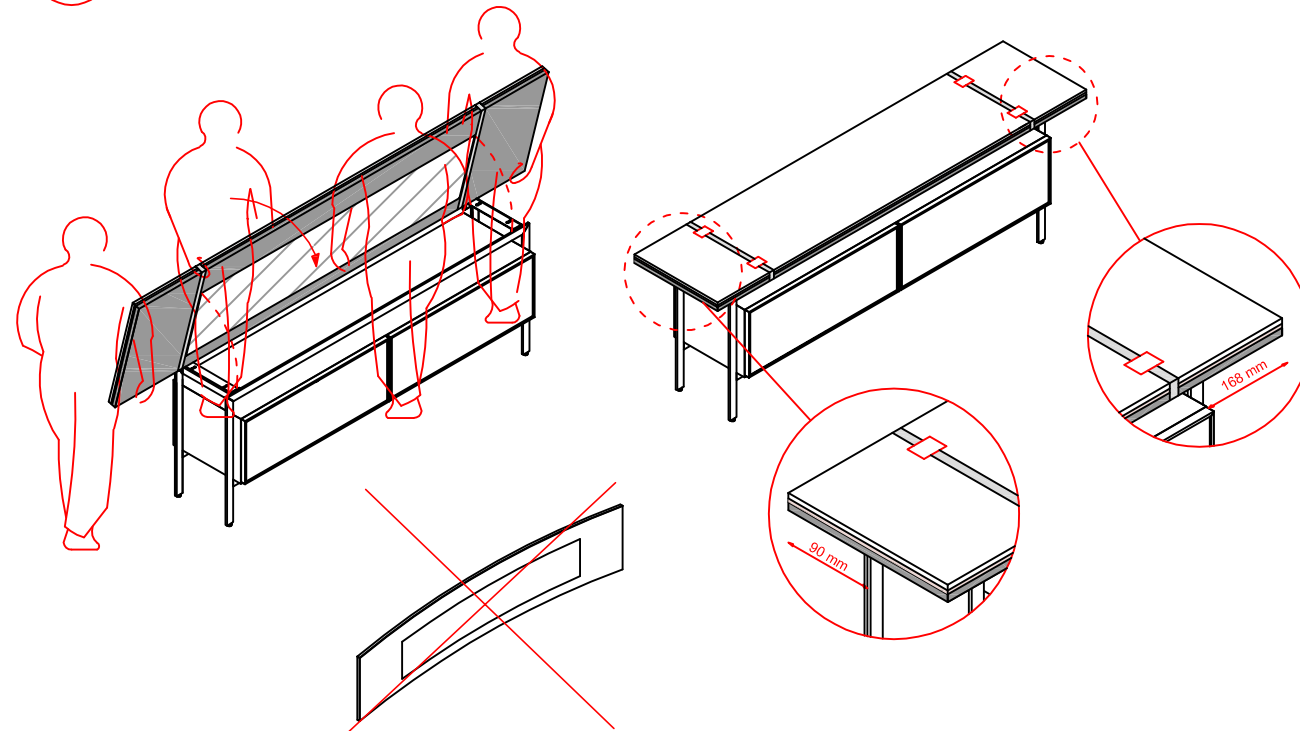

**EVITAR LA FLEXIÓN DE LA PIEZA  
AVOID BENDING THE PIECE**

**6** QUITAR LAS BRIDAS, TRABAS Y EL TABLERO DE ESPUMA  
REMOVE THE FLANGES, THE WOODEN BARS AND THE FOAM

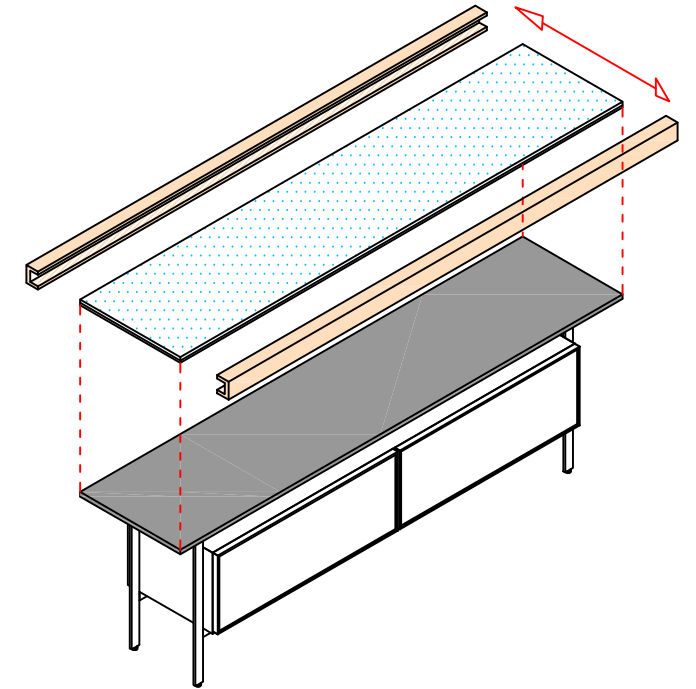

HERRAJE - FERRATJE - FITTINGS - EISENBESCHLAG - QUINCALLERIE - FERRAMENTA - HERRAJE - FERRATJE - FITTINGS - EISENBESCHLAG - QUINCALLERIE - FERRAMENTA - HERRAJE - FERRATJE - FITTINGS - EISENBESCHLAG